

# ARCHITECTURAL RECORD



SEPTEMBER 1957

BUILDING TYPES STUDY : SHOPPING CENTERS



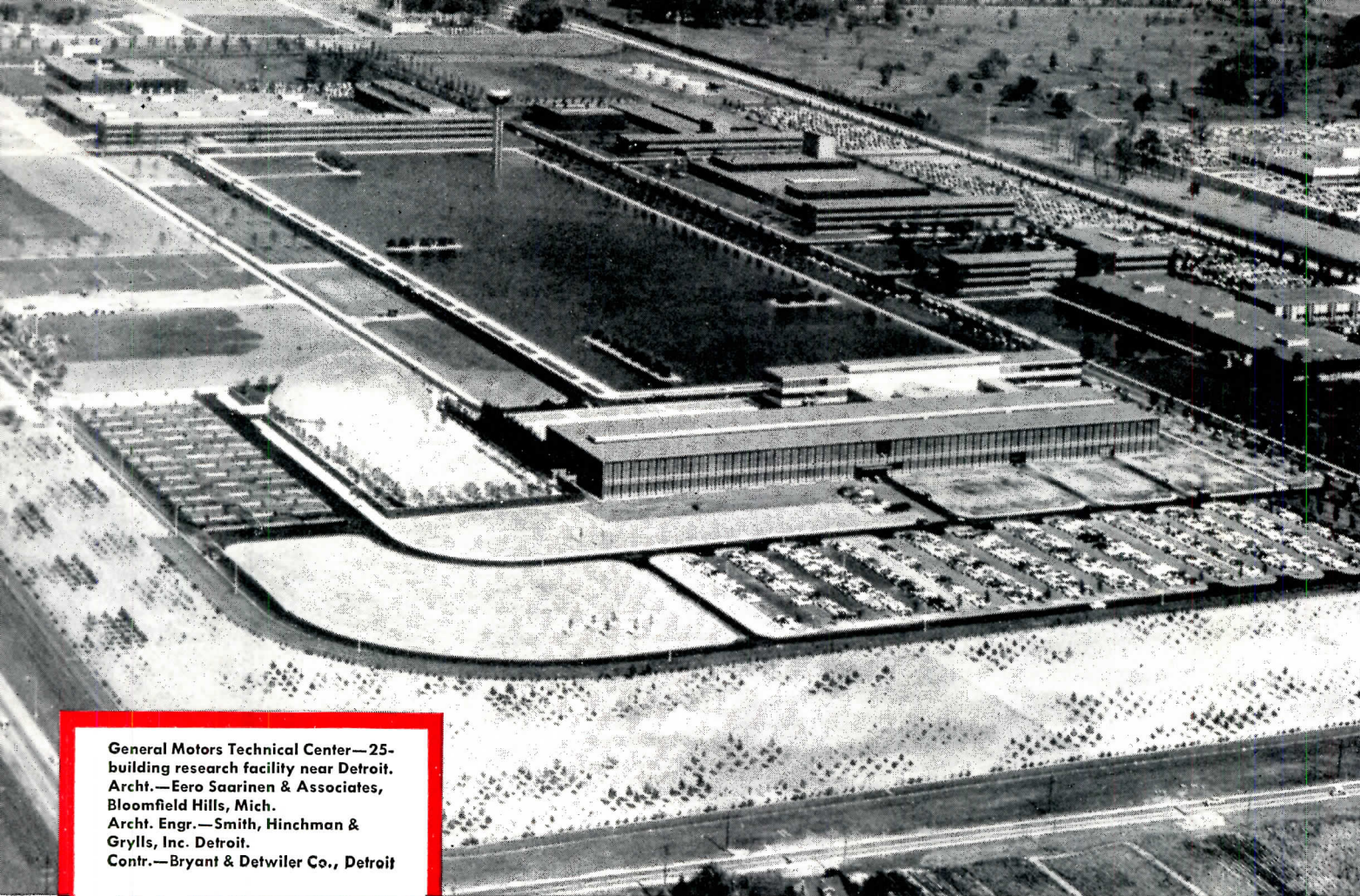

General Motors Technical Center—25-building research facility near Detroit.  
 Archt.—Eero Saarinen & Associates, Bloomfield Hills, Mich.  
 Archt. Engr.—Smith, Hinchman & Grylls, Inc. Detroit.  
 Contr.—Bryant & Detwiler Co., Detroit



## Top Quality Concrete in General Motors Technical Center Obtained with **POZZOLITH**

In the construction of General Motors Technical Center— one of the world's great industrial research facilities — Pozzolith was employed in the more than 150,000 cubic yards of structural concrete as an aid in producing uniform, top quality concrete.

The use of Pozzolith both improves concrete quality, and provides this better quality concrete at a lower cost in place. These benefits result from:

**1. control of water content . . .** Pozzolith makes possible lowest water content for a given workability.

**2. control of rate of hardening . . .** Pozzolith provides desired time for handling, placing and finishing under widely varying job conditions.

**3. control of entrained air . . .** Pozzolith provides optimum air content without sacrificing strength or other desired qualities.

Call in any one of our more than 100 full-time fieldmen to discuss and demonstrate the benefits of Pozzolith controls for your current project. Or write for a copy of new data booklet—"Pozzolith Concrete Control Facts".



**THE MASTER BUILDERS co.**

DIVISION OF AMERICAN-MARIETTA CO.

General Offices: Cleveland 3, Ohio • Toronto 9, Ontario • Export: New York 17, N. Y.

Branch Offices In All Principal Cities • Cable: Mastmethod, N. Y.



# ARCHITECTURAL RECORD

September 1957 Vol. 122 No. 3

Copyright 1957 by F. W. Dodge Corporation, with all rights reserved. Copyright not claimed by F. W. Dodge Corporation on front cover and on pages 171, 173, 175 and 178. ARCHITECTURAL RECORD (combined with AMERICAN ARCHITECT and ARCHITECTURE) is published monthly, except May 1957 when semi-monthly, by F. W. Dodge Corporation, 10 Ferry Street, Concord, New Hampshire. Editorial and executive offices: 119 West 40th Street, New York 18, New York. Western editorial office, 2877 Shasta Road, Berkeley 8, California.

## STAFF OF ARCHITECTURAL RECORD



H. Judd Payne, *Publishing Director*; Robert F. Marshall, *General Manager*; John Knox Shear, A.I.A., *Editor-in-Chief*, Marshall T. Ginn, *Circulation Manager*; Emerson Goble, *Managing Editor*; James S. Hornbeck, A.I.A., *Senior Associate Editor*; Elizabeth Kendall Thompson, A.I.A., *Senior Associate Editor and Western Section Editor (Berkeley, California, Office)*; Robert E. Fischer, *Associate Editor (Engineering)*; Florence A. van Wyck, *Associate Editor*; Jeanne M. Davern, *Associate Editor (News)*; Herbert L. Smith, Jr., A.I.A., *Associate Editor*; Ernest Mickel, Dan Street (Washington), John Caulfield Smith, M.R.A.I.C. (Canada), *Contributing Editors*; Grace M. Anderson, *Assistant Editor*; Margaret R. Fuerst, *Assistant Editor (Engineering Assistant)*; Helen E. Cook, *Editorial Assistant (Production)*; Dianne Thomas, *Editorial Assistant*; Eugene H. Hawley, *Design Director*; Thomas L. McArthur, Mary Ann Godfrey, *Design*; Sigman-Ward, *Drafting Consultant*; Thomas S. Holden, *Industry Relations Consultant*; Clyde Shute, *Statistical Consultant*; George Cline Smith, *Economics Consultant*; Clifford Dunnells, Jr., *Field Research Consultant*; Daniel J. Howe, Jr., *Public Relations Consultant*.

## TABLE OF CONTENTS

### The Record Reports

Air Academy Chapel: New Design, Old Controversy	9
News of Architecture Abroad	15
News of Architecture Abroad. Architecture in the U.S.S.R.: A Report from Within. <i>By Alexander Vlasov</i>	16B
Meetings and Miscellany	21
Architectural Beauty in Steel: An Exhibit	28
A Washington Report. Designing Against Nuclear Weapons: The New Handbook. <i>By Ernest Mickel</i>	32
News from Canada. <i>By John Caulfield Smith</i>	36
Washington Topics. <i>By Ernest Mickel</i>	46
Construction Cost Index	54
Required Reading	58
Calendar and Office Notes	362
Current Trends in Construction	404

### An Educational Oasis

A consciously starry-eyed school design to look over the idea that an elementary school might look inward toward itself and its children, not outward toward community center functions. At any rate it presents some delightful ideas, spaces, courtyards and concepts for the stimulation of children.

Oasis School Project; Charles R. Colbert, Architect 167

### Man-Made the Buildings

Mark Thomas Inn, Monterey, Calif.; John Carl Warnecke, Architect 177

### Decoration Rides Again

The author, viewing with fresh alarm, classifies decoration as: 1. Applied; 2. Insinuated; 3. Invited; roughly in the order of their offensiveness to him.

An article by Robin Boyd 183

COVER: *Flags marking entrance to Roosevelt Field Shopping Center, Nassau County, L.I.; I. M. Pei & Assoc., Architects; © Ezra Stoller photo*

Continued on next page



# ARCHITECTURAL RECORD

Continued from page 5

## Danish Craftsmanship Builds a Town Hall

A Critique by *C. E. Stousland*. Rödovre Town Hall; Arne Jacobsen, Architect

187

## The Court House Concept

A thoughtful look at the "introverted" house, its history and its place in present-day residential planning.

An article by *Ian L. McHarg*

193

## Highlights of Venezuela's Burgeoning New Architecture

Exhibit Prepared by Cipriano Dominguez, Luis Ramirez, Paolo Gasparini and Mateo Manaure

201

## Building Types Study 250 — Shopping Centers

This study on shopping centers narrows its attention to the spaces between and around the buildings; these are the areas that create a delightful, or depressing, shopping center, the areas most often neglected.

*Shopping Can Be a Pleasure*. Introduction by *James S. Hornbeck*

205

Roosevelt Field Shopping Center, Nassau County, L. I.; A Webb & Knapp Project; I. M. Pei & Associates, Architects

206

Random Observations on Shopping Centers and Planning for Pedestrians. An article by *Richard M. Bennett*, Architect

217

Old Orchard Shopping Center, Skokie, Ill.; Loeb, Schlossman & Bennett, Architects

220

Humbertown Shopping Center, Toronto, Ontario, Canada; Victor Gruen & Associates, Architects & Engineers

229

## Architectural Engineering

Potentialities of High Velocity Air Conditioning. By *Frank Walsh*

233

Technical Roundup

241

Product Reports

244

Time-Saver Standards: Relative Area Enclosure Properties of Plane Shapes — I, II & III

247

## Index to Advertising

406

## OFFICERS OF THE F. W. DODGE CORPORATION

**James McV. Breed**, Chairman of the Board; **Paul Abbott** and **Thomas S. Holden**: Vice Chairmen of the Board; **Howard Barringer**, President; **Irving W. Hadsell**, **Chauncey L. Williams**: Executive Vice Presidents; **Howard M. Thompson**, Vice President and Treasurer; **Julius T. Little**, **Robert F. Marshall**, **T. Oliver Morgan**, **O. O. Paulsell**, **H. Judd Payne**, **George Cline Smith**: Vice Presidents; **Carl S. Bennett**, **Clinton C. Bennett**, **Ralph M. Hairston**, **Roy J. Hard**, **Arthur D. Prior**, **Richard H. Ray**, **John M. Williams**: Regional Vice Presidents; **Edwin H. Freed**, Assistant Vice President and Comptroller; **Walter F. DeSaix**, **Clifford G. Dunnells, Jr.**, **Gault Eastman**, **Clyde Shute**, **Marc Wayne**: Assistant Vice Presidents; **Sanford D. Stockton, Jr.**, Secretary; **William C. Breed, Jr.**, **George W. Morgan**: Assistant Secretaries; **Irving B. Satin**, Assistant Treasurer.

## OTHER F. W. DODGE SERVICES

Dodge Reports — Dodge Statistical Research Services — Sweet's Catalog Services — Dodge Books — Dodge Mailing Service — The Modern Hospital — The Nation's Schools — College and University Business — Hospital Purchasing File — Chicago Construction News — Daily Pacific Builder — Denver Daily Journal — Real Estate Record & Builders Guide.

Members of Audit Bureau of Circulations and Associated Business Publications. ARCHITECTURAL RECORD is indexed in Art Index, Industrial Arts Index and Engineering Index.

Every effort will be made to return material submitted for possible publication (if accompanied by stamped, addressed envelope), but the editors and the corporation will not be responsible for loss or damage.

Subscription prices: Published monthly except May 1957 when semimonthly. U. S., U. S. Possessions and Canada: \$5.50 per year; other Western Hemisphere countries, Spain, to those who by title are architects and engineers, \$9.00 per year. Single copy price except Mid-May 1957 issue \$2.00; Mid-May 1957 issue \$2.95. Beyond Western Hemisphere, excluding Spain, to those who by title are architects and engineers, \$9.00 per year for 12 monthly issues not including Mid-May 1957 issue. Subscriptions from all others outside U. S., U. S. Possessions and Canada for 12 monthly issues, not including Mid-May issue, \$24.00 per year. Change of address: subscribers are requested to furnish both old and new addresses, sending if possible stencil impression from magazine wrapper; allow four weeks for change.





THE RECORD REPORTS

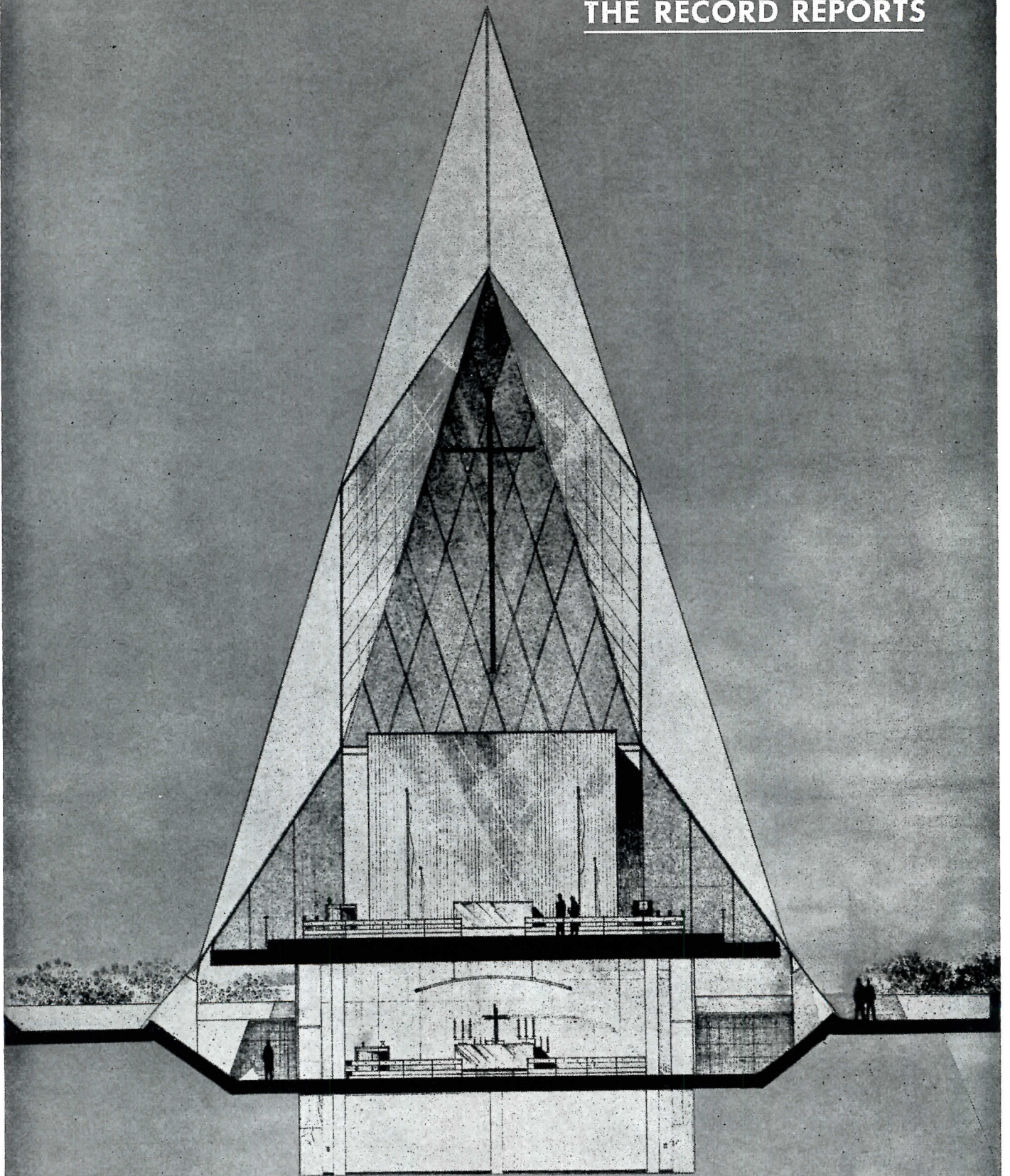

**AIR ACADEMY CHAPEL: NEW DESIGN, OLD CONTROVERSY**



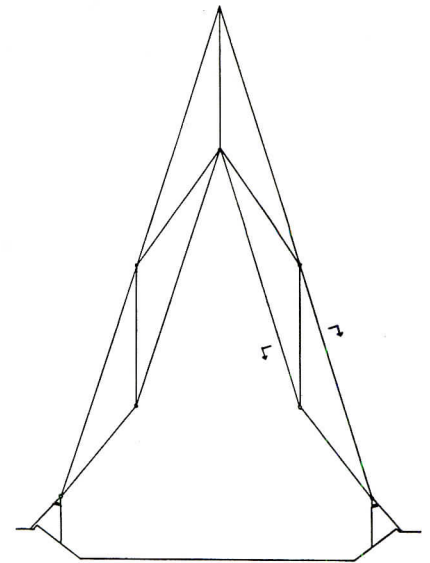
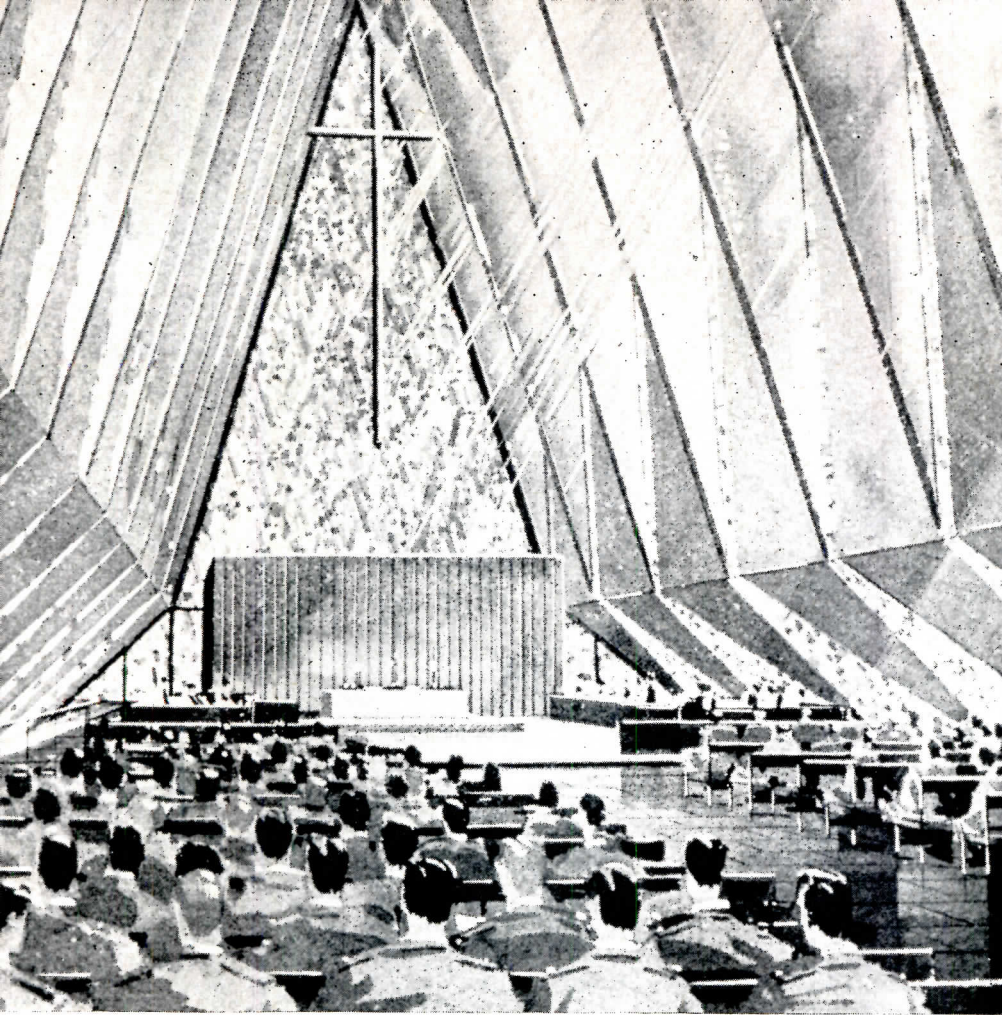

*Protestant Chapel interior (above), envisioned as lofty space infused with light reflected through colored glass panels on folded surfaces of tetrahedrons. Lowest areas under sloping walls will be reserved for Air Force memorials*

*Catholic Chapel interior (right) in rendering made before diamond pattern was established for coffering of prestressed concrete ceiling. Glass side walls look on granite abutments from which tetrahedrons spring, trees and sky beyond*

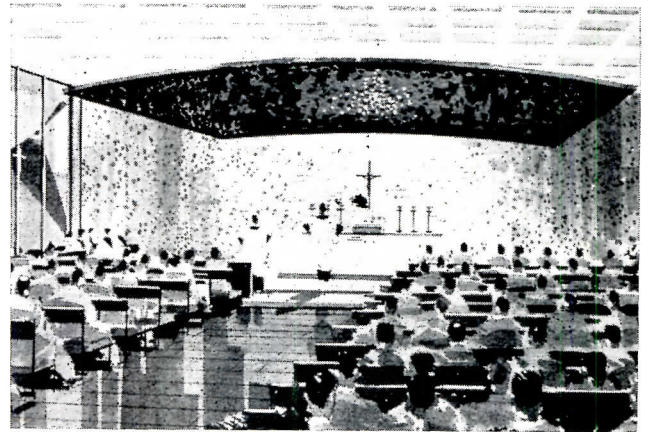

The new design concept for the much-discussed chapel of the United States Air Force Academy (Skidmore, Owings and Merrill, Architects) was unveiled last month for purposes of the Congressional debate on the \$3 million sought for its construction. In the House of Representatives, whose "debate" provided as depressing a spectacle of uninformed public discussion of public architecture as the infamous sessions on Academy design two years ago, the appropriation was at first refused and then restored — mainly on the plea that otherwise the Academy would open next

fall with no chapel at all. The Senate approved the appropriation without debate. The design the architectural Don Quixotes of the House tilted away at as "a monstrosity," "a rectangular accordion stretched out on the floor" and "a row of polished tepees" has the enthusiastic approval of the Air Force itself and of its consulting architects, Pietro Belluschi, Eero Saarinen, Welton Becket and Roy Larson.

The basic program for the chapel called for a Protestant Chapel seating 900, a Catholic Chapel seating 500 and a Jewish Chapel seating 100. The solu-

tion as the architects evolved it was to enclose all three faiths in a single simple structural envelope while imparting its own distinctive character to each of the separate chapels within. The esthetic effort was toward a form, expressed by today's methods in today's materials, which would provide a quality of space, light and structure achieved — with the materials and methods of their times — by the great church builders of the past, most notably, of course, in the Gothic.

The structure is a space frame of tetrahedrons, to be made of steel or aluminum pipe sections and enclosed with



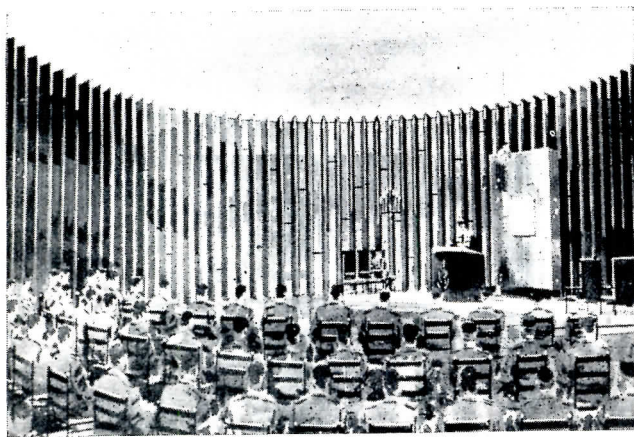
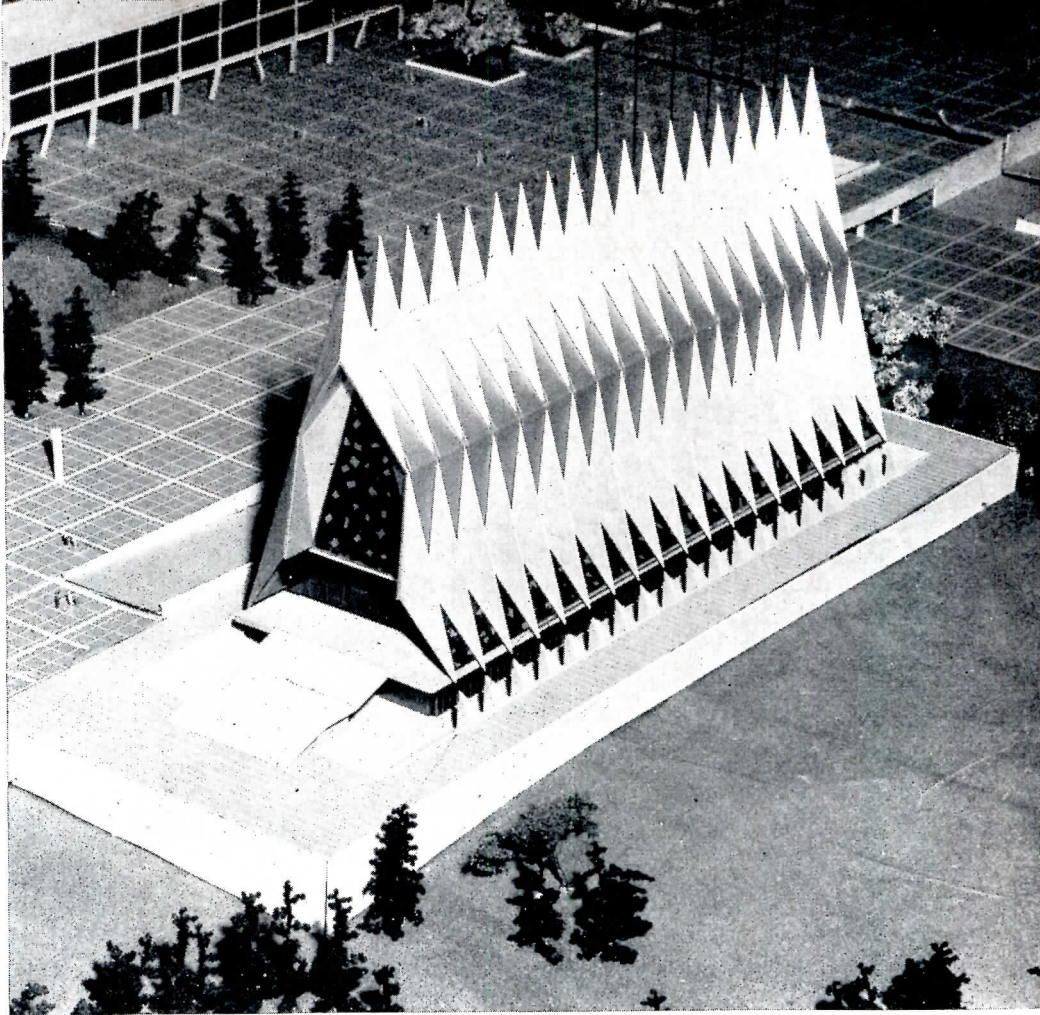
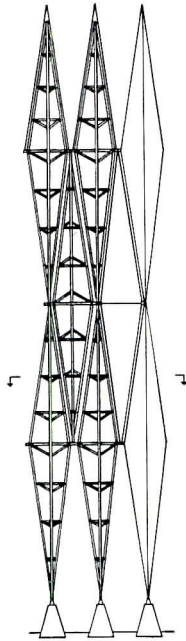

*Closeup of Chapel model with Administration Building (not designed with crooked columns) visible beyond Court of Honor in background. Ramp for cadet access is partly visible to left of Chapel; podium provides public outlook for Cadet Academic Area*

*Jewish Chapel (left), which shares lower level with Catholic, is circular, with enclosure of vertical grillage and clear glass inserts opening to the foyer. There is terrace access from both the Catholic and the Jewish Chapels*

aluminum panels, filled in with colored glass and supported on hinges by granite abutments set in a sloping wall of granite pavers, the whole resting on a granite podium. It rises 136 ft from hinge to pinnacle, has an overall length of 280 ft and in width is 84 ft from hinge to hinge. Bay width reaches 14 ft.

Within, the three chapels are disposed on two levels (see page 9), with the Protestant Chapel on the upper level and the Catholic and Jewish Chapels below.

The fusion of light and structure resulting from the reflection of light

through the colored glass panels on the folded surfaces of the tetrahedrons is "the main expression and articulation" of the Protestant Chapel, which will have a nave 64 ft by 168 ft, reaching a height of 94 ft. The large windows at either end will have light transmission gaged to avoid conflict with the light diffusing patterns following the tetrahedrons.

The Catholic Chapel, with a nave 56 ft wide, 113 ft long and 19 ft high, will be essentially horizontal in character, with a prestressed concrete ceiling coffered in a diamond pattern to recall the tetra-

hedron shape. This pattern, as it meets the side walls, establishes a rhythm of two spacings for the mullions, the narrower one providing the location for the Stations of the Cross. Important to the character of the chapel will be the view through its tinted glass side walls of the granite abutments springing from their sloping wall of granite pavers, and of sky and trees beyond.

The Jewish Chapel is circular in shape, with a diameter of 42 ft and a height of 19 ft. It is enclosed by a vertical grillage with inserts of clear glass opening to the foyer.



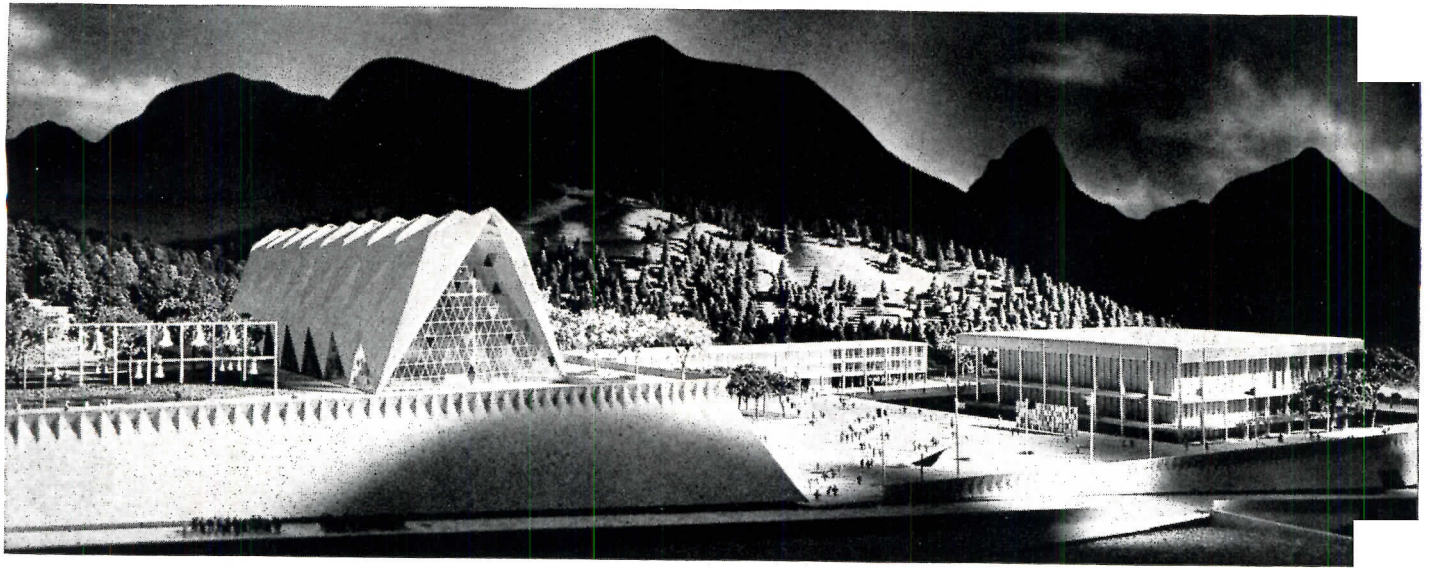

**AIR ACADEMY CHAPEL**

*Above: Architectural concepts of Chapel, Administration Building and Social Hall as first made public two years ago. Below: Models reflecting current concepts of Cadet Quarters (foreground), Chapel and Administration Building*

© Ezra Stoller

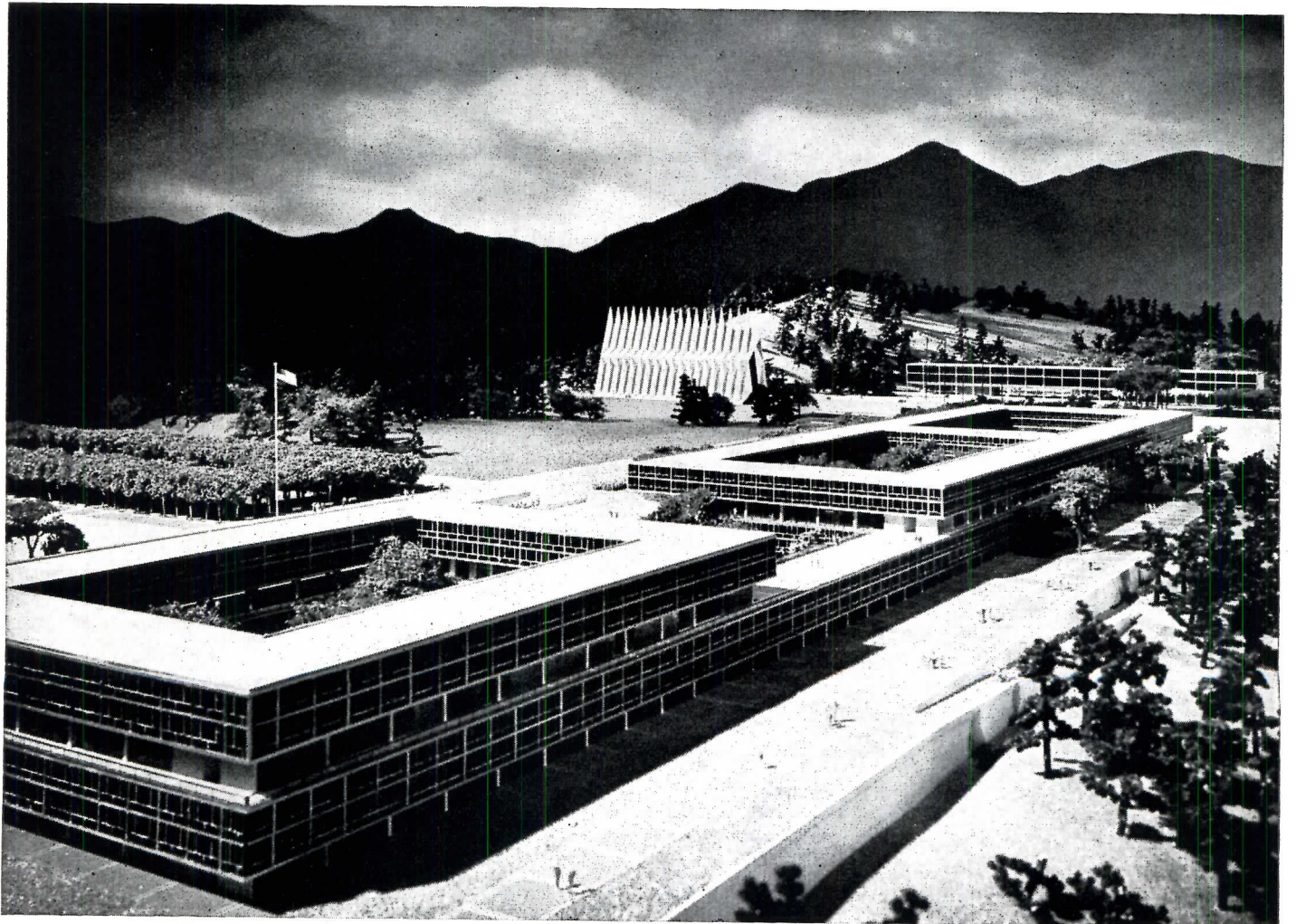



# SHOWROOM . . . INSURANCE OFFICE . . .

the flooring spec: Armstrong Linotile

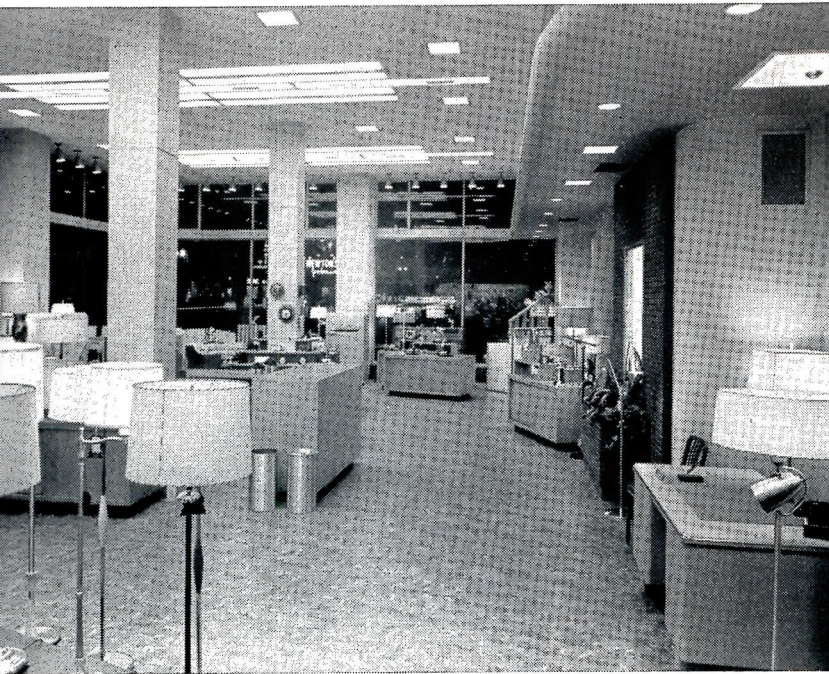

## MINIMUM MAINTENANCE

It takes a resilient floor with unusual characteristics to stand up under the dirt, grit, and grime tracked into this busy off-the-street showroom. Armstrong Linotile meets this condition with minimum maintenance because of its exceptionally dense, smooth composition. This floor has proved itself in countless stores and public buildings of all types.

Iowa Electric Light and Power Company  
Cedar Rapids, Iowa

**architect:** Dean Barnhizer, Company Architect

## EXCEPTIONAL PRACTICALITY

In this bustling insurance office, Linotile withstands the static loads of heavy office furniture without showing permanent indentation. Especially designed for busy areas, Linotile doesn't wear into traffic lanes; reduces the clatter of footsteps.

American Hardware Mutual Insurance Company  
Minneapolis, Minnesota

**architect:** Thorshov and Cerny, Inc., Architects and Engineers

Armstrong Linotile — an exclusive Armstrong Floor — has an enviable record of more than 40 years for decorative versatility, ease of maintenance, and exceptional durability. A full 1/8" thick, the wearing surface extends through the entire thickness of the tile. It should not be confused with linoleum cut into blocks. Armstrong Linotile is specially processed for superior resistance to abrasion and indentation . . . is capable of withstanding static loads up to 200 lbs. per sq. in. Linotile is offered in two stylings — an unusually bold marbleizing and a subtle tone-on-tone effect; in many colors and sizes. It may be installed on all types of suspended sub-floors.

The Armstrong Cork Company makes all types of resilient floors. Therefore, unbiased recommendations can be made for every flooring need. For product and technical information, flooring samples, complete specifications, design and color scheme assistance, call the Architectural-Builder Consultant in your nearest Armstrong District Office or write direct to Armstrong Cork Company, Floor Division, 709 Rock Street, Lancaster, Pennsylvania.

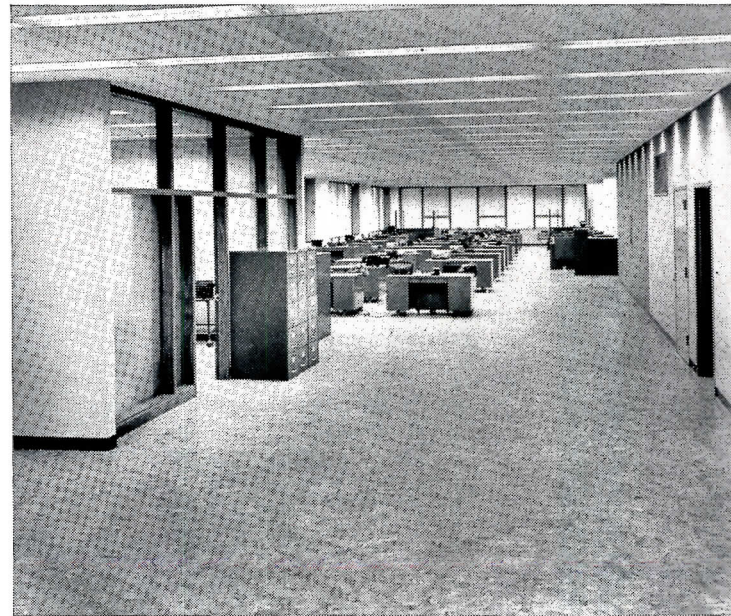

# Armstrong FLOORS

Approximate Installed Prices per Sq. Ft. (Over concrete, minimum area 1000 sq. ft.)

<p><b>20¢ to 35¢</b></p> <p>Decoray® Linoleum Tile Asphalt Tile, 1/8" (A, B, C, D) Linoleum, light gauge Asphalt Tile, 3/16" (A, B)</p>	<p><b>35¢ to 45¢</b></p> <p>Linoleum, standard gauge Asphalt Tile, 3/16" (C, D) Linoleum, 1/8" ("Battleship") Greaseproof Asphalt Tile Cork Tile, 3/32"</p>	<p><b>45¢ to 60¢</b></p> <p>Corlon® (Sheet Vinyl) Linoleum, 1/8" Cork Tile, 1/8" Excelon® Tile (Vinyl-Asbestos) 1/8"</p>	<p><b>60¢ to 70¢</b></p> <p>Rubber Tile, 1/8" Cork Tile, 3/16" Linotile® Corlon (Hydrocord® Back) Linoleum (Cushion-Eze® Back**)</p>	<p><b>70¢ to 90¢</b></p> <p>Custom Corlon Tile (Homogeneous Vinyl) 3/32", 1/8" Cork Tile, 5/16" Rubber Tile, 3/16" Corlon (Cushion-Eze Back)</p>	<p><b>95¢ to \$1.30</b></p> <p>Custom Vinyl Cork Tile Imperial® Custom Corlon Tile</p>
---	---	--	--	--	--

\*\*PATENT PENDING



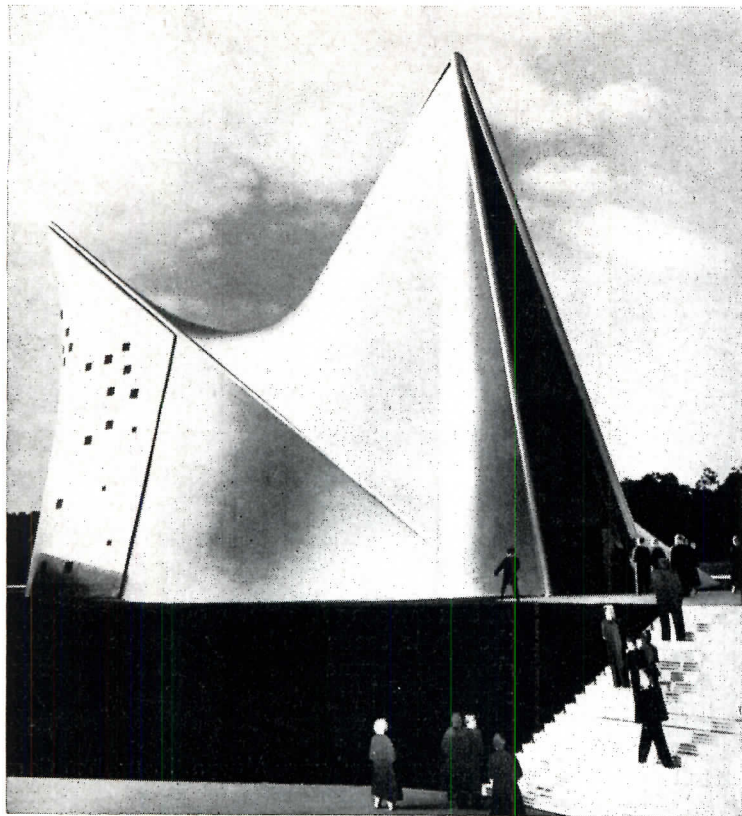

**CORBU AT BRUSSELS** — Philips Pavilion for Brussels World's Fair 1958, to house demonstrations being developed for the Belgian electronics firm of "light and sound integrally combined," has been designed by Le Corbusier as an architectural system of two inclined surfaces, with the highest point about 66 ft above grade and a volume of 141,600 cu ft from a surface area of 5380 sq ft; there are no supplementary columns. Surfaces consist of 2000 concrete panels less than two in. thick and of different shapes, each covering an area of about 10.76 sq ft; they are held together with steel wires less than three tenths of an inch thick

**SKYPORT FOR LONDON** — This is "Skyport One," designed by architect James Dartford as a project of the Glass Age Development Committee of Pilkington Brothers Ltd., which describes it as "an example of the city-center air station which will be needed in the year 2000." The proposal is a 500-ft-high landing deck designed as a "triple turn-around" air stop and supported by three shafts each consisting of a finned structural drum encased in an outer cylinder of glass and housing elevators serving the landing deck. The shafts straddle a 200-ft-high triple-wing building. Landing deck consists of three pentagonal landing and take-off pads each about 120 ft in diameter. Scheme assumes vertical takeoffs and landings

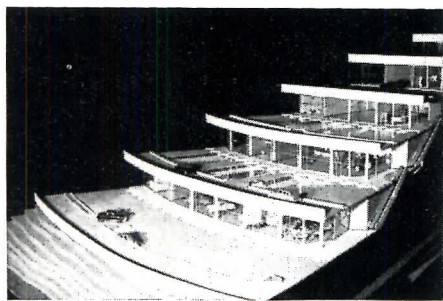
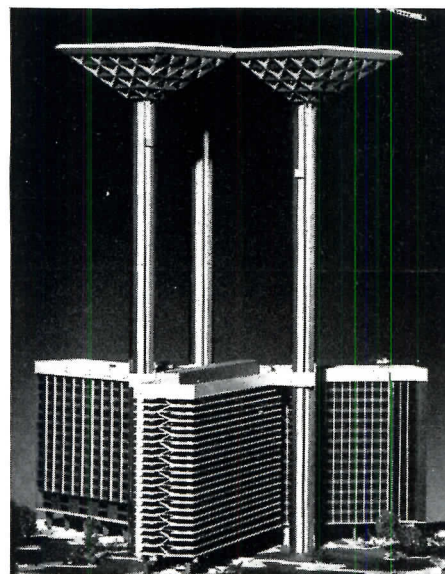

**BUSINESS CENTER FOR CARACAS** — Under construction on a mountain overlooking Caracas is the "Helicoid," a \$25 million business and commercial center designed by Venezuelan architect Jorge Romero Gutierrez. Facilities include 320 small stores, industrial showrooms, hotel, swimming pool, garages, business offices and — in the dome — a "Great Hall" for international trade fairs. The building, 365 ft high, is "contoured" to the side of the hill: 10 stories high on one side and 25 on the other; its base will cover 25 acres

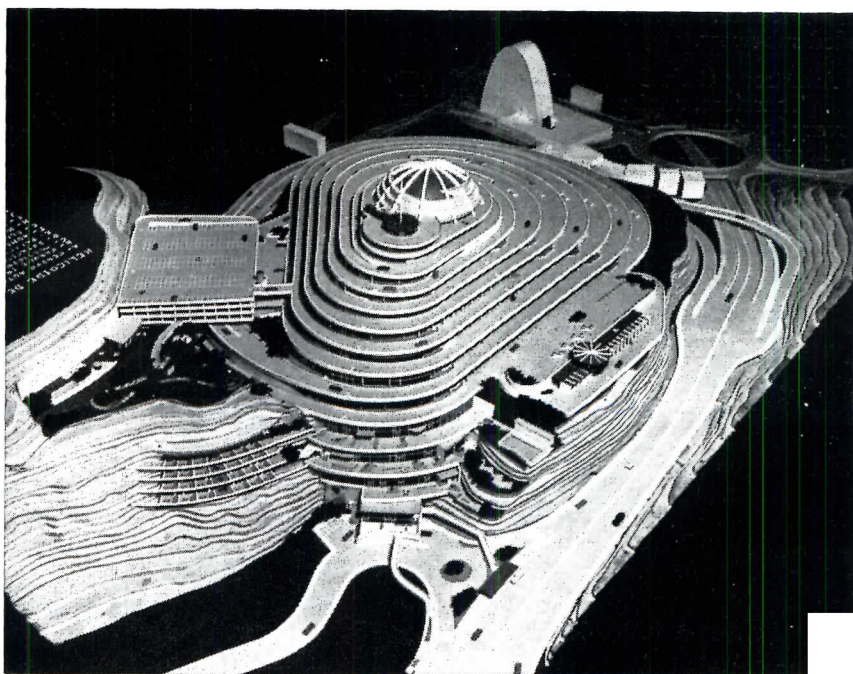



Today's smartest floors wear KENTILE

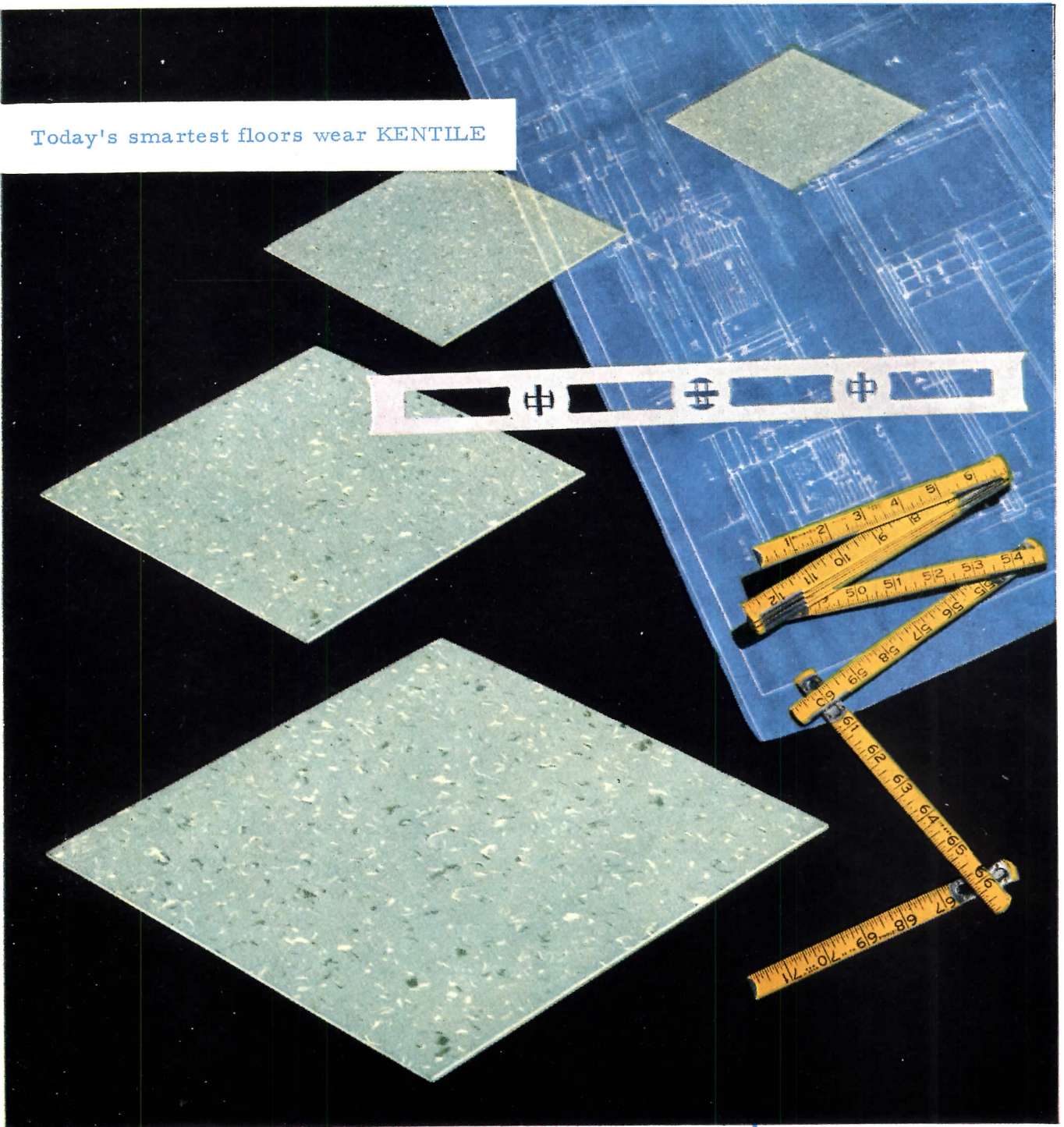

This is Terrazzo...  
in KENTILE® Solid Vinyl Tile

...latest, liveliest, loveliest tile of all --  
with a wide range of soft, rich colors straight  
out of the Italian Renaissance!

**KENTILE FLOORS**

available in Solid Vinyl, Vinyl Asbestos, Cushion-back Vinyl,  
Asphalt, Cork and Rubber Tile...over 150 decorator colors!

SPECIFICATIONS:

SIZE: 9" x 9"

THICKNESSES:  
5/64", 1/8"

COLORS:

Regular -- 8  
DeLuxe -- 7  
Decorator -- 7



This is an account, presented exactly as received, of the organization of architecture and construction in the Soviet Union today. It was written at the request of the RECORD by Alexander Vlasov, now vice president of the Academy of Construction and Architecture of the U.S.S.R., whom American architects will remember as the architect member of a Soviet delegation which visited the U.S.A. in the fall of 1955 at the invitation of the National Association of Home Builders (AR, Nov. 1955, page 48). It is the first published report by a U.S.S.R. architect of the organization of the building industry in the Soviet Union which followed the much-publicized "reorganization" in that field. The accompanying photographs were selected by Mr. Vlasov in response to the RECORD's request for illustrations which would in Mr. Vlasov's opinion reflect the character of Soviet architecture today.

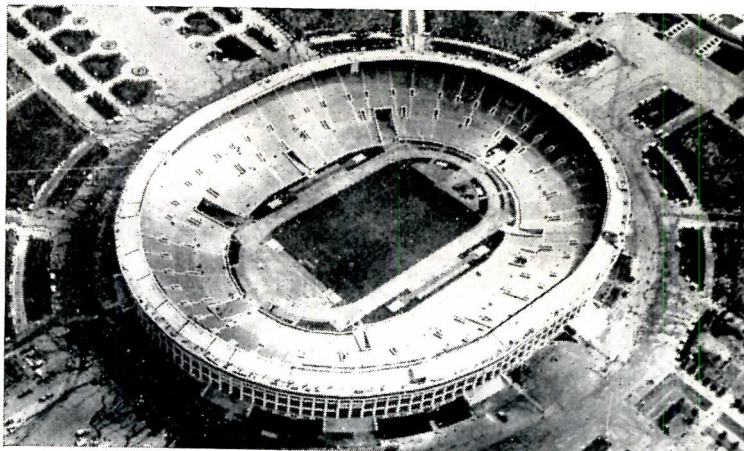

*V.I. Lenin Central Stadium of Moscow; Alexander Vlasov, Architect*

ARCHITECTURE IN THE U.S.S.R.: A REPORT FROM WITHIN

Construction in the Soviet Union is expanding with every passing year. Last year's investments in construction amounted to 93.5 billion rubles as against 6.9 billion rubles in 1929. Factories and mills, houses, schools, hospitals and theaters are going up throughout the land. Hundreds of plants are beginning to manufacture ready-made structural elements which are being delivered to the construction sites.

This industrial method of construction has given rise to a number of interesting problems in the sphere of building and architecture.

The Academy of Construction and Architecture, the country's highest institution in these fields and uniting well-known scientists, engineers and architects, was organized in the Soviet Union to aid the further industrialization of the erection of buildings, raise the quality of work, lower its costs and reduce completion schedules. The Academy has been entrusted with the task of coordinating all research work dealing with building construction being carried on by scientific organizations as well as college laboratories. A number of research institutes are functioning under the auspices of the Academy.

The Institute of City and District

Planning deals with problems of planning and reconstruction of new and existing cities, as well as minor settlements. This organization handles questions connected with the placing of industrial enterprises, their dwelling areas and transport facilities.

Building and equipping grounds of industrial enterprises, as well as problems concerning typical factory buildings for various branches of industry, are taken up by the Institute of Industrial Buildings and Installations.

New typical layouts for housing construction are taken care of by the Institute of Housing, which carefully studies problems of convenient house planning, cost and mass production of building elements for this type of structures. A part of the work of this institute is the design of plumbing and water supply fittings, as well as furniture.

The Institute of Public Buildings does work on rationalization of designs for schools, hospitals, sanatoriums and other communal structures, and their proper location in cities and towns.

Rural planning and design of buildings connected with all branches of agriculture — livestock barns, buildings for production and storage, rural hydraulic

*(Continued on page 338)*

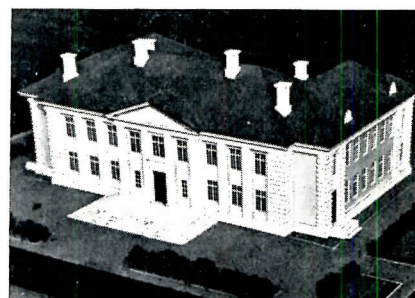

*Model of "type project of village school designed by Architect Velikanov. A type project of an urban school by the same architect was awarded a prize and adopted in many districts of the country"*



*Model of "village nursery designed to accommodate 44 children"; U. Kararya and A. Ivanov, Architects*



*Model of the future Byelorussian Railway Station Square; name of architect not available*





*Philadelphia* where the **accepted** word for elevators is **OTIS**

In the City of Brotherly Love, a new feeling of friendliness marks the widespread acceptance of completely automatic OTIS elevators. Business people enjoy touching electronic elevator buttons for themselves and other tenants. They assist visitors. Everybody likes automatic AUTOTRONIC elevators for their greater freedom of action. In Philadelphia, 66% of the elevators are by OTIS—first to introduce completely automatic elevating. As always, progress is expected of the leader. Outstanding value has made OTIS the accepted word for elevator quality in the cities of the world.

Automatic Autotronic® or Attendant-Operated Passenger Elevators • Escalators • Trav-O-Lators Freight Elevators • Dumbwaiters • Elevator Modernization and Maintenance • Electronic Systems  
 The Baker-Raulang Company, an Otis subsidiary, is the maker of Baker Gas and Electric Industrial Trucks \*



**OTIS ELEVATOR COMPANY**

260 11th Avenue, New York 1, N. Y.  
 Offices in 501 cities around the world





ARCHITECTURAL BEAUTY IN STEEL: AN EXHIBITION

Having since 1928 carried on a program honoring "Beauty in Steel Bridges," the American Institute of Steel Construction has this year done the same thing for buildings in an exhibition, "Structural Steel in Today's Architecture." The exhibition, which previewed in New York, will tour the country under the auspices of the American Federation of Arts.

Though not specially composed for the purpose, the exhibition helps to celebrate the centenary of the Bessemer converter process, which made rapidly produced steel available for the first time in large quantities. The period has seen the demand for fabricated structural steel climb from an estimated 1.5 million tons in 1910 to nearly three times that figure in 1957, when estimated bookings for 4,050,000 tons are expected.

The exhibition schedule: September — Los Angeles; October — Del Coro  
(Continued on page 372)

3. Mile High Center, Denver; I.M. Pei & Associates, architects. 4. Alexander Memorial Center, Georgia Institute of Technology; Aeck Associates, architects. 5. Manufacturers Trust Company, New York City; Skidmore Owings & Merrill, architects. 6. Bandshell, St. Petersburg, Fla.; William B. Harvard, architect. 7. Alcoa Building, Pittsburgh; Harrison & Abramovitz, architects. 8. Northeast Branch, Seattle Public Library, Seattle; Paul Thiry, architect. 9. Socony-Mobil building, New York City; Harrison & Abramovitz, architects

1. Coliseum, Charlotte, N. C.; A. G. Odell Jr. & Assocs., architects. 2. Lake Shore Drive Apartments, Chicago; Ludwig Mies van der Rohe, Pace Assocs., Holsman, Holsman, Klekamp & Taylor, architects

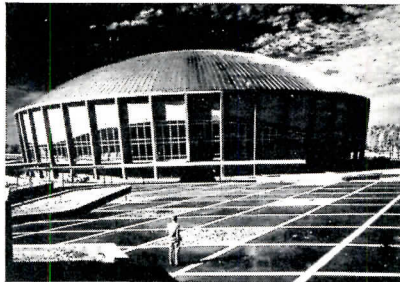

1

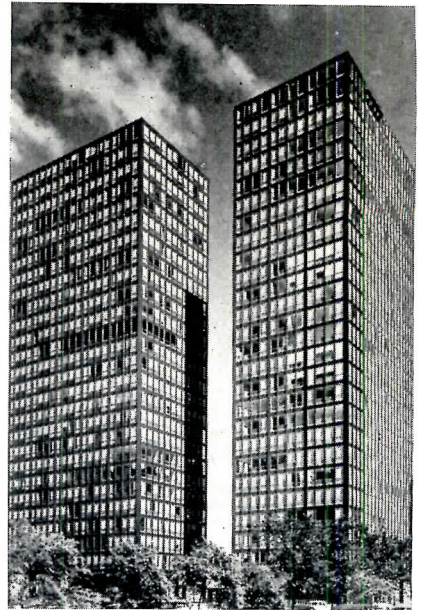

2

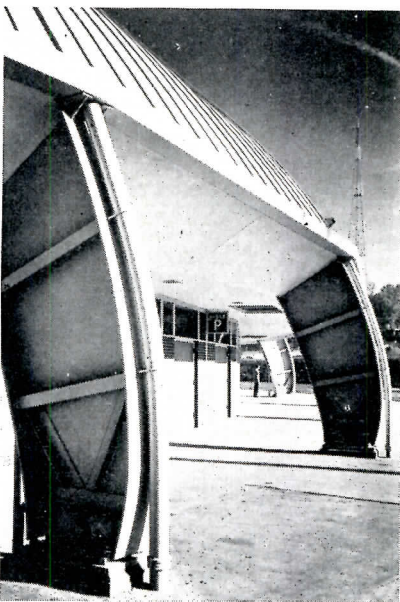

4

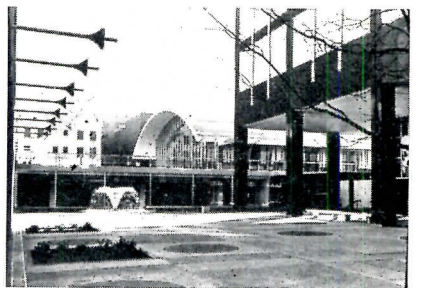

3



5



7

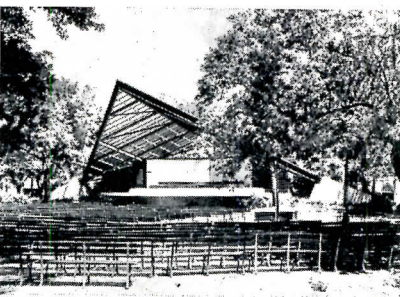

6



8



9





*Design  
Possibilities...  
Astronomical!*

**HAUSERMAN  
MOVABLE WALLS OF  
REYNOLDS  
ALUMINUM**

When Hauserman and Reynolds, together, offer you the versatility of aluminum for interior walls, design scope is almost limitless. You choose from any number of embossed textures... multiplied by innumerable colors and countless panel arrangements. Aluminum extrusions provide still another multiplier... joining wall sections with hairlines or narrow beads or wide posts in any profile and in any finish, including brilliant anodizing.

Total possibilities... astronomical!

And all this beauty is combined with the basic advantages of Hauserman Movable Walls... earliest occupancy, lowest maintenance, lifetime service. Write for literature. Or consult the Yellow Pages (under PARTITIONS) and call your nearby Hauserman representative.

The E. F. HAUSERMAN COMPANY,  
6726 Grant Ave., Cleveland 5, Ohio.  
Hauserman of Canada, Ltd., Toronto, Ontario.



See "Circus Boy", Sundays, NBC-TV. Watch for Reynolds on "Disneyland", ABC-TV Network.



**DESIGNING AGAINST NUCLEAR WEAPONS: THE NEW HANDBOOK**

A broad outline of many design problems characteristic of a nuclear age and the new text on blast-resistant and shelter design are contained in the 579 pages of a major report, "The Effects of Nuclear Weapons," recently prepared by the Department of Defense for the Atomic Energy Commission.

This volume updates a previous report, "The Effects of Atomic Weapons," published in 1950. Dr. Samuel Glasstone, who was executive editor of the earlier publication, compiled and edited the text of the new report. It is available, paper-bound, from the Superintendent of Documents, Washington 25, D. C., for two dollars a copy.

The long-span leap from atomic to nuclear in less than a decade has brought with it manifold problems for the architect and engineer faced with the question of designing for blast resistance — or no — or how much — and the design of shelters as such.

The government again makes it clear in this report that because of the uncertainties of a nuclear age — point of blast, distance from ground zero, wind direction and fallout — the owner has to make a decision on the relative value of his structure to determine the extent to which it should be blast resistant. Under a section on blast-resistant structures, it is stated: "The choice of the

blast load for design purposes must be based on a balance between the cost and the overall importance of the particular structure."

The AEC volume notes that after the loading has been prescribed, a dynamic analysis of the proposed structure must be undertaken to determine the stiffness and ultimate strength necessary to prevent collapse or to limit the plastic deformation to the optimum which has been decided upon. The limit would be determined by the functional requirements of the activities or operations for which the structure is to be used.

The critical deformation may be restricted to that which will prevent the

*(Continued on page 350)*

**BLAST DAMAGE: SIX KINDS OF TEST STRUCTURES**

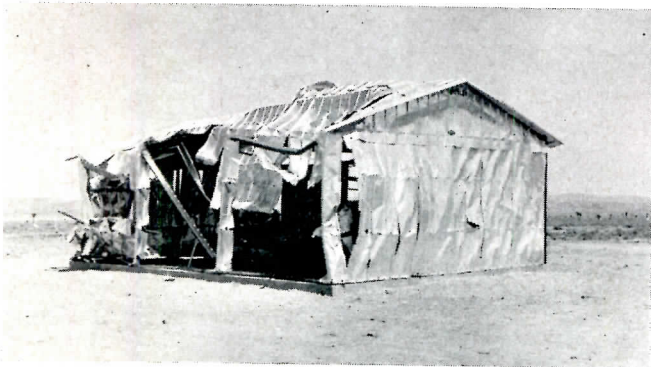

*STEEL — Rigid-frame building; 3.1 psi overpressure*



*STEEL — Self-framing panels; 3.1 psi overpressure*



*WOOD — Two-story frame house; 5 psi overpressure*



*BRICK — Unreinforced two-story house; 5 psi overpressure*

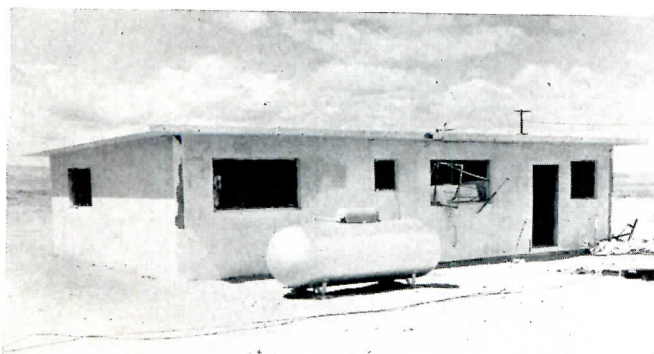

*CONCRETE — Reinforced precast; 5 psi overpressure*



*MASONRY BLOCK — Reinforced; 5 psi overpressure*



# the happiest room in the house!"

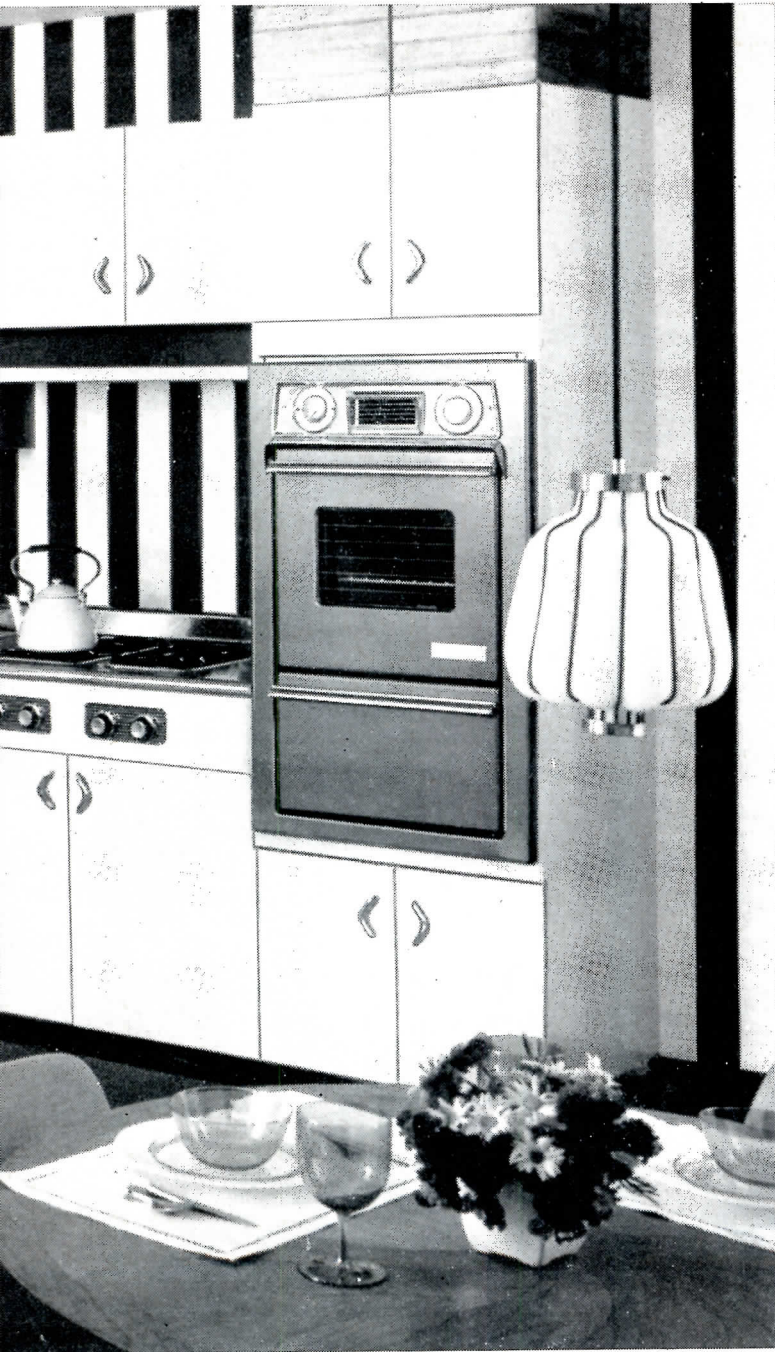

**Here's Why** *this nationally advertised Youngstown Kitchens slogan is important to architects*

- **Immediate Builder and Consumer Acceptance.**
- **Eye Appealing Kitchen Design with America's most popular steel kitchen units.**
- **Flexibility of design with precision engineered modules.**
- **Economy of home construction with quick, easy installation.**

Yes, the Youngstown Kitchen that you specify will be the happiest room in the house from your standpoint as well as from your client's. Youngstown Kitchens quality manufacture has made this the standard in steel kitchen components. Home owners know and recognize this famous name. They're proud of the clean efficiency and amazing durability of Youngstown Kitchens and they'll praise your choice of decorator designed cabinet colors that blend so perfectly with modern kitchen decor. From your point of view Youngstown Kitchens offer a complete kitchen service with a complete variety of units to suit every installation from 1-wall efficiency kitchens to superb custom kitchens including dishwashers and gas or electric wall ovens and counter-top ranges. A complete kitchen planning service is available at your request, too. Why not see your Youngstown Kitchens Representative now or mail the coupon below for full details.

 **Youngstown Kitchens**

DIVISION OF **AMERICAN-Standard**  
WARREN OHIO



**YOUNGSTOWN KITCHENS**

Dept. AR9  
Warren, Ohio

Please send me complete details and specifications on your complete line of Youngstown Kitchens units.

NAME \_\_\_\_\_

FIRM NAME \_\_\_\_\_

STREET \_\_\_\_\_

CITY \_\_\_\_\_ STATE \_\_\_\_\_



SPOTLIGHT ON TERMINALS AS AIRPORT SPENDING DOUBLES

The five terminal buildings shown in rendering on this page are major projects under way in the Federal government's continuing program of expanding airport facilities across Canada. This program, which had until this year centered mainly on extension of runway facilities and parking aprons, service facilities and the like, is now concentrating more largely on development of new airports and terminal buildings; and in the year that began April 1 estimated expenditures will reach \$38,318,000, an increase of \$17.5 million over the 1956 appropriation.

Planning and design are the responsibility of the Architectural Department of the Department of Transport, whose policy as officially described is to engage architects in private practice to work with Chief Architect W. A. Ramsay "wherever possible."

Basic to the development of all the individual schemes, whether or not private architects are commissioned, are the extensive studies by Mr. Ramsay's staff on major planning considerations, not forgetting the new problems imposed by the imminence of the "jet age" in air transport.

To take the Montreal terminal, largest of the current projects, as an example, the Department's studies of the problem of passenger circulation, reviewed in the light of the impact of jets with their promise of greatly increased passenger loads, have produced the two-finger scheme shown here. As described by the Department: "With the introduction in the near future of jet-propelled aircraft, the projected corridor type of finger has come under review to determine if this is the best method for the new type of aircraft. . . . The conclusion has been reached that the Montreal Terminal Building will be constructed with two 'fingers' attached to the terminal building — one 'finger' providing gates for domestic aircraft and the other providing gates for trans-border and trans-Atlantic aircraft. These 'fingers' will each be two-level corridors, the upper corridor for enplaning passengers and the lower corridor for deplaning passengers. In appearance the 'fingers' will match the terminal building, but particular attention is being paid to the details of their construction so that, at a future date if conditions demand, these 'fingers' may be modified or converted to a detached or isolated gate system."

GANDER— Architects, Durnford, Bolton and Chadwick; estimated cost: \$2.7 million

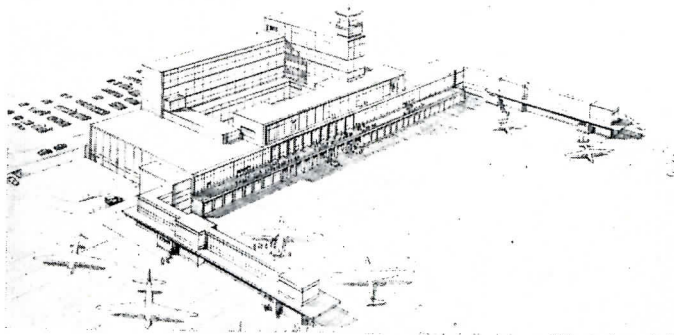
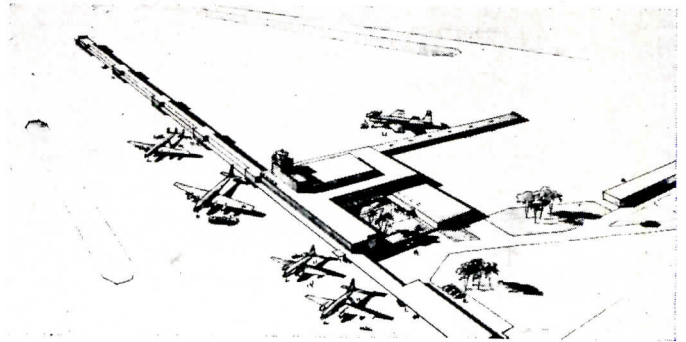

MONTREAL— Architects, Isley, Templeton, Archibald, Larose & Larose; estimated cost, \$10-12 million

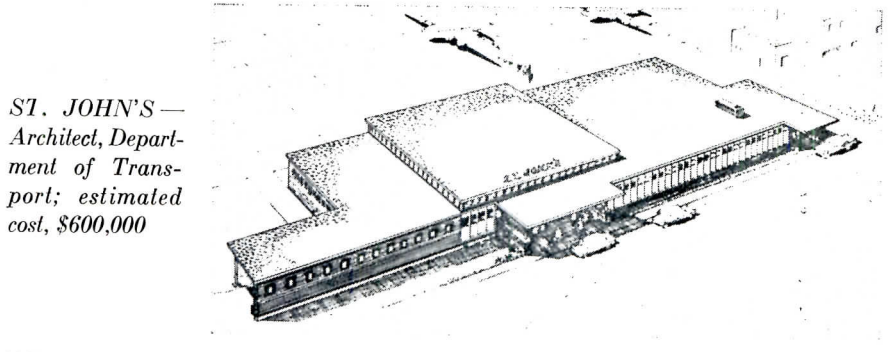

ST. JOHN'S— Architect, Department of Transport; estimated cost, \$600,000

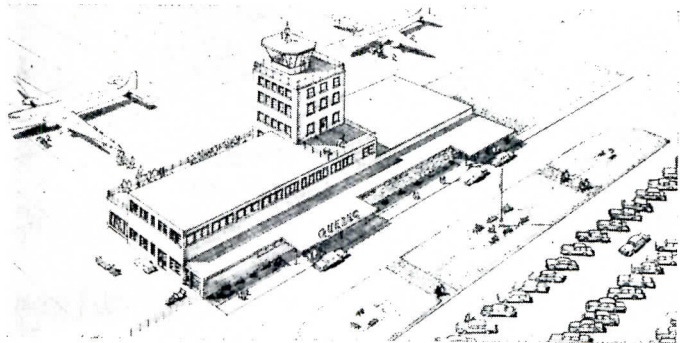

QUEBEC CITY— Architect, Department of Transport; estimated cost, \$750,000

OTTAWA— Architects, Gilleland & Strutt; estimated cost, \$4.5 million

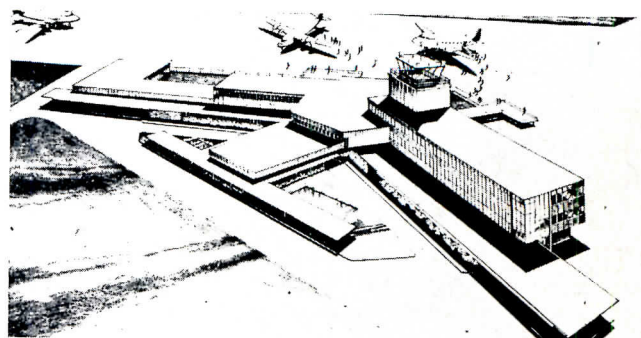

(Continued on page 40)



# POWERS Pneumatic Temperature Control for Heating

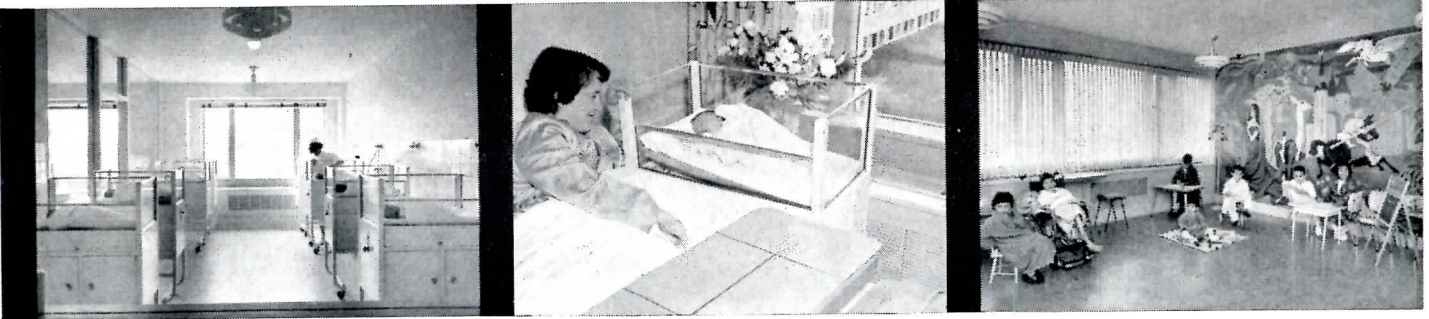

NOW, it's Canada's First Completely Air Conditioned Hospital with



**Powers Temperature and Humidity Control** helps Nurses to work more effectively and care for more patients. Surgeons operate with less fatigue and strain. Patients recover sooner and require less service.

**Powers Pneumatic Thermostats** maintain set temperatures constantly. They need no daily checking or readjusting.

**Over 619 Powers Heating-Cooling Thermostats and 708 PACKLESS Control Valves** regulate the volume of chilled or heated water to unit air conditioners used in the perimeter areas of the buildings.

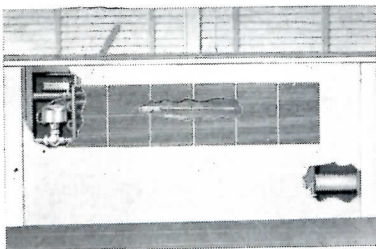

(C49)

## POWERS

### Quality System of Air Conditioning Control

**St. Boniface Hospital** with 670 beds, offers the most advanced facilities and equipment for diagnosis and treatment of disease, patient care and comfort.

**Year 'round Air Conditioning** regulated by Powers individual room control provides the right temperature required for every hospital activity. Powers pneumatic thermostats are used in:

13 OPERATING ROOMS, central sterilizing and supply area, recovery and delivery rooms, 9 nurseries, attractive rooms for patients, offices, public spaces, pharmacy, laboratories, radiology and therapy departments, kitchen, cafeteria and dining rooms, laundry, autopsy room, solariums for convalescent patients and a colorful playroom for children.

**Central Supply Units** furnish properly conditioned primary air and heated or chilled water to over 600 unit air conditioners in the

perimeter areas of the buildings. Occupants in each space can dial the temperature they like best.

**Interior Zones**, operating rooms and other spaces receive conditioned air from central supply units. Here Powers control automatically adjusts temperature and humidity to the requirements of occupancy and outside weather.

**Nurses Home and School of Nursing** with over 200 students, have direct radiation throughout controlled by Powers.

**Powers Thermostatic Shower Controls** insure comfort and safety of patients and nurses.

**Are You Planning a New Hospital** or any other type of building? Ask your architect or engineer to include a Powers Quality System of Temperature Control. You will help insure utmost comfort and lowest cost for upkeep.

## THE POWERS REGULATOR COMPANY

SKOKIE, ILLINOIS

Offices in chief cities in U.S.A., Canada and Mexico

65 Years of Automatic Temperature and Humidity Control

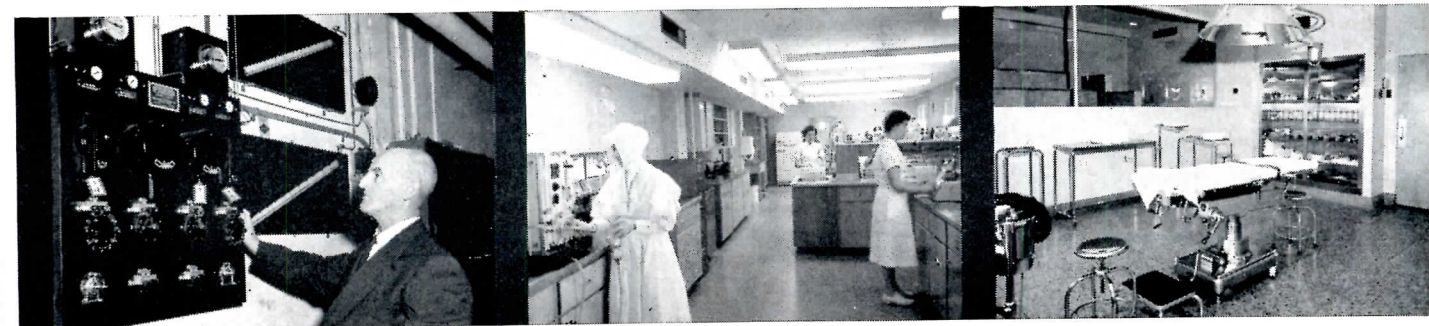



THE RECORD REPORTS  
 NEWS FROM CANADA  
 (Continued from page 36)

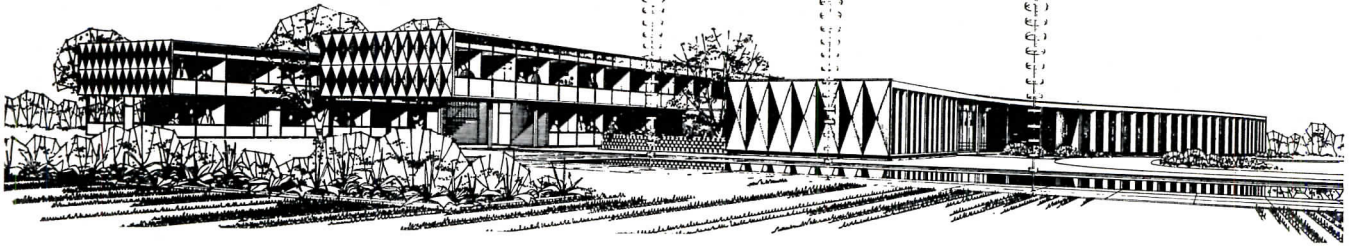

FIRST AWARD in Alcan competition was won by Henry Fliess of Toronto

**LOOK UP!**

*...something new is coming...*

**L.B.Q.\***

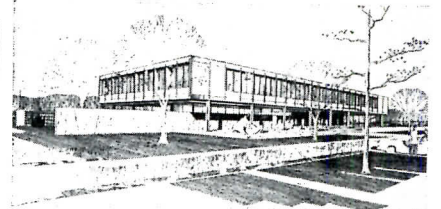

SECOND AWARD — Blankstein & Coop of Winnipeg submitted this design

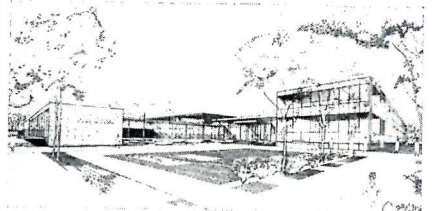

THIRD AWARD — Scheme of D. F. Lebensold and J. Schreiber, Montreal

**WINNERS ARE ANNOUNCED  
 IN ALCAN COMPETITION**

Henry Fliess, Toronto architect, was winner of the first award of \$6000 in a competition sponsored by the Aluminum Company of Canada Ltd. for the design of a sales office building.

Second award of \$3000 was won by Blankstein & Coop, Winnipeg; and the third award of \$1000 went to D. F. Lebensold & John Schreiber, Montreal. Four honorable mentions of \$500 each were awarded to Walter Aguis, Toronto; Eugene Janiss, Toronto; Jean-Paul Pothier, Montreal; and W. A. Salter and D. E. Flemming of St. Catharines.

Site for the proposed building is on the outskirts of Toronto close to the future Etobicoke Municipal Center. Estimated cost of the building is \$500,000.

Seventy architects submitted entries in the competition, which was conducted in accordance with the R.A.I.C. code.

Jury was composed of P. C. Amos, Montreal; A. F. Duffus, Halifax; H. H. G. Moody, Winnipeg; W. R. Souter, Hamilton; and J. H. Wade, Victoria. Richard E. Bolton, Montreal, served as professional adviser.

(Continued on page 42)





It pays to specify products  
protected under the paint by

# CrysCoat<sup>®</sup>

from STEEL WINDOWS

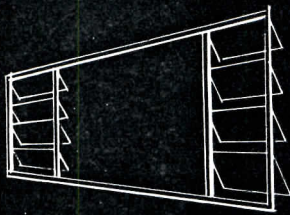

to LIGHTING FIXTURES

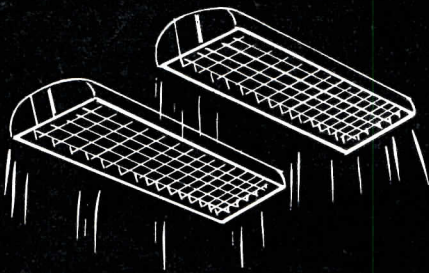

from PARTITIONS

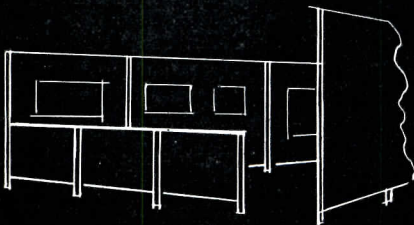

to LOCKERS

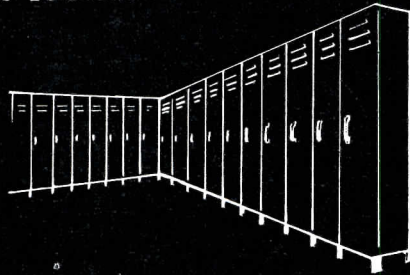

*Partial list of  
products protected  
by CrysCoat*

- Air Conditioners
- Awnings
- Cabinets
- Controls
- Diffusers
- Discharge Fans
- Electric Switch Boxes
- Floor Fans
- Heating—Ventilating Units
- Kitchen Ranges
- Kitchen Stoves
- Kitchen Stove Hoods
- Lighting Fixtures
- Locks
- Lockers
- Metal Lawn Furniture
- Office Equipment
- Office Furniture
- Oil Burners
- Partitions
- Radiator Enclosures
- Radios
- Refrigerators
- Steel Windows
- Television Sets
- Typewriters
- Water Coolers

It has been proved year after year on many different architectural products that nothing surpasses Oakite CrysCoat for bonding paint to metal . . . for blocking creeping rust and preventing paint from peeling at nicks and scratches . . . for increasing the ability of the paint to protect against corrosion.

When an architect specifies that steel architectural products be Crys-Coated, he is assuring building owners more complete satisfaction with their investment.

For information about CrysCoated products, write Oakite Products, Inc., 83 Rector Street, New York 6, N. Y.

**CrysCoat** *paint-bonding treatment makes architectural products look better . . . last longer*





# THE RECORD REPORTS

## NEWS FROM CANADA

(Continued from page 40)

### SHAKESPEARE THEATER OPENED IN STRATFORD

A \$1.5 million theater designed to seat more than 2000 people within "intimate" distance of a central stage and incorporating in its structure the existing reinforced concrete amphitheater has replaced the tent used for the past four years by the Shakespearean Festival

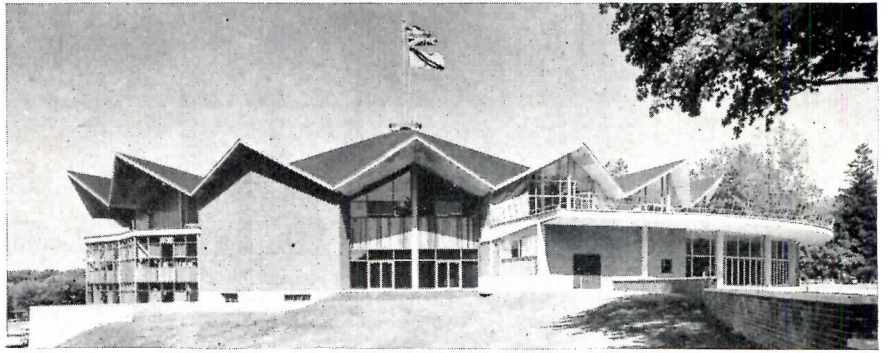

Below right — 1. Gallery promenade. 2. Auditorium promenade. 3. Catwalk. 4. Auditorium. 5. Existing amphitheater and stage. 6. Stage. 7. Orchestra platform. 8. Backstage. 9. Loft. 10. Dressing rooms. 11. Upper loft. 12. Crush fall. 13. Wardrobe workshop. 14. Property room. 15. Open promenade

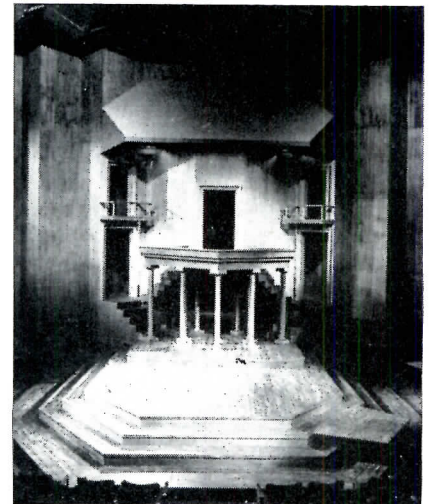
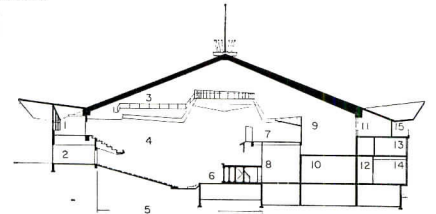

Theater at Stratford, Ont. Rounthwaite and Fairfield were the architects.

The auditorium, 150 ft in diameter, surrounds the stage to the extent of 220 degrees of a circle. There are no interior columns; the 200-ton folded concrete slab roof, 70 ft above grade, is supported by 34 steel beams stressed partly to a central hub and partly to a reinforced concrete tension ring around the perimeter of the building, for a 150-ft clear span.

The new theater opened in July and theatrical reaction was enthusiastic. "The authorities responsible for the Canadian Festival," said *New York Herald Tribune* critic Walter Kerr, "have created something more than a dazzlingly handsome and superbly functional playhouse. They have given us the only really new stage, and the only really new actor-audience experience, of the last hundred years on this continent."

(Continued on page 44)

# LOOK UP!

...something new is coming...

# L.B.Q.\*





MEADOWS—Terre Haute

Yeager Architects, Terre Haute, Ind.



163rd STREET—Miami

Archts. Gamble, Pownall & Gilroy, Fort Lauderdale

**Brasco**  
**SPECIFIED**

"All metal store front and entrance materials called for on plans, details or in specifications shall be Brasco Construction, as manufactured by Brasco Manufacturing Co., Harvey, Ill."

SOUTHDALE—Minneapolis Walgreen's Design Dept., Approved by Victor Gruen

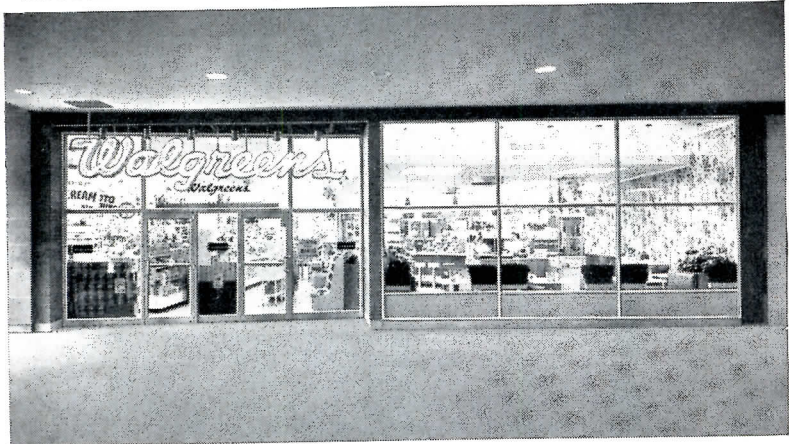

LAMAR AIRWAYS—Memphis

Archts. Sidney H. Morris & Associates, Chicago



**for the most attractive,  
most active, most talked  
about shopping centers**

OSHAWA—Oshawa, Ont.

Designed by Principal Investments, Ltd., Toronto  
Consultants, John Graham Co., Seattle



SOUTHGATE—Tucson

Architects, Blanton & Cole, Tucson, Ariz.



**YOU CAN BUILD IT BETTER WITH BRASCO**  
Store Fronts • Aluminum Entrances • Facing Metals • Brasco Wall  
**MANUFACTURING CO. • HARVEY, ILL.**



For Complete Information Please Write Dept. R709



# THE RECORD REPORTS NEWS FROM CANADA

(Continued from page 42)

## INTERNATIONAL COMPETITION OFFERS \$25,000 FIRST PRIZE

An international architectural competition for design of an \$18 million city hall for Toronto will open October 1. In the first of two stages, eight winners will be selected to compete for the \$25,000 first prize; the seven losers will receive awards of \$7500 each. Decision of a five-

man jury of internationally known architects will be made known very shortly; composition of the jury, to include two Canadians, was not immediately announced. Prof. Eric R. Arthur is professional adviser.

Toronto City Council has given official sanction to tentative rules and conditions governing the competition. Entrants must lay out the entire civic square, bounded by Bay, Queen, Chestnut and Hagerman Streets. The area not built upon will become a park and at least one pool must be included.

The present Registry Office is to be demolished. Professor Arthur has said that he regards it as "a very correct building of the classical period, but a very dull one. It is not a work of art to be preserved, and its presence would greatly hamper site planning for the new city hall."

The Registry Office will be replaced by space in the new city hall. Latter building is to have a floor area of 660,000 sq ft. One of the competition requirements is that the design must make provision for future expansion.

## 1957 CONSTRUCTION TOTAL NOW SEEN AT \$6.9 BILLION

Canadian investment in construction may reach \$6.9 billion or three and a half per cent more than originally expected, according to revised estimates on capital spending issued by the Department of Trade and Commerce.

This new estimate would put the 1957 construction program about nine per cent above last year's record total of \$6.4 billion.

The increase is primarily due to upward revisions in the intentions of the fuel and power industry and mining.

## ARCHITECTURAL GRADUATES SCARCEST IN '57 TILL '61

A survey conducted by the R.A.I.C. shows that graduates of Canadian schools of architecture in 1957 are likely to be fewer than in any of the five years until 1961. Here are the estimates:

Institution	1957	1958	1959	1960	1961	Total
<b>Ecole des Beaux Arts</b>	10	21	18	17	33	99
<b>McGill</b>	17	25	25	29	33	129
<b>Toronto</b>	30	34	37	40	78	219
<b>Manitoba</b>	21	20	33	28	38	140
<b>British Columbia</b>	16	10	20	16	30	92
<b>Total</b>	94	110	133	130	212	679

## Contracts Awarded: Comparative Figures\*

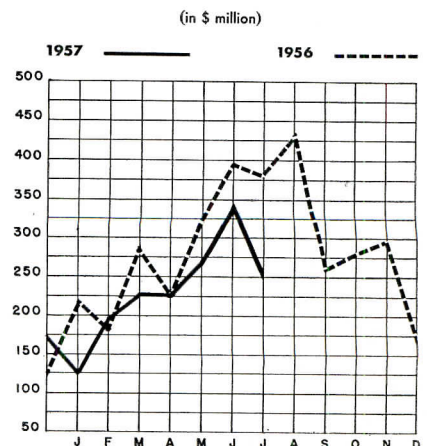

\*Compiled by the Editor and staff of *The Building Reporter*, from information collected by Maclean Building Reports.

# LOOK UP!

*...something new is coming...*

# L.B.Q.\*



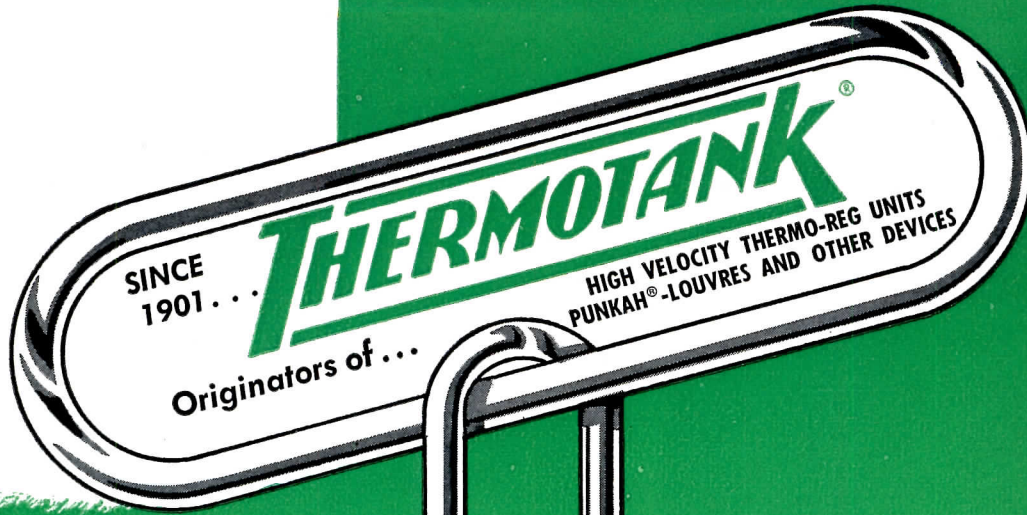

LINKED TOGETHER

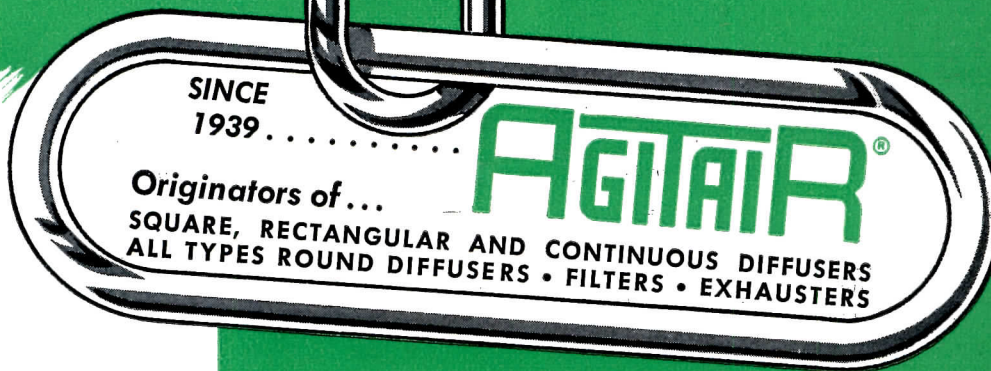

● For your convenience  
in solving **ALL**  
air handling  
requirements

*Sold Exclusively  
by Representatives for*

**AIR DEVICES INC.**

185 MADISON AVENUE  
NEW YORK 16, N. Y.



# THE RECORD REPORTS: CONSTRUCTION COST INDEXES

Labor and Materials

U. S. average 1926-1929=100

Presented by Clyde Shute, manager, Statistical and Research Division, F. W. Dodge Corp., from data compiled by E. H. Boeckh & Assocs., Inc.

## NEW YORK

## ATLANTA

Period	Residential		Apts., Hotels Office Bldgs. Brick and Concr.	Commercial and Factory Bldgs. Brick and Concr.		Brick and Steel	Residential		Apts., Hotels Office Bldgs. Brick and Concr.	Commercial and Factory Bldgs. Brick and Steel	
	Brick	Frame		Brick	Brick		Brick	Frame		Brick	Brick
1930	127.0	126.7	124.1	128.0	123.6		82.1	80.9	84.5	86.1	83.6
1935	93.8	91.3	104.7	108.5	105.5		72.3	67.9	84.0	87.1	85.1
1939	123.5	122.4	130.7	133.4	130.1		86.3	83.1	95.1	97.4	94.7
1946	181.8	182.4	177.2	179.0	174.8		148.1	149.2	136.8	136.4	135.1
1947	219.3	222.0	207.6	207.5	203.8		180.4	184.0	158.1	157.1	158.0
1948	250.1	251.6	239.4	242.2	235.6		199.2	202.5	178.8	178.8	178.8
1949	243.7	240.8	242.8	246.4	240.0		189.3	189.9	180.6	180.8	177.5
1950	256.2	254.5	249.5	251.5	248.0		194.3	196.2	185.4	183.7	185.0
1951	273.2	271.3	263.7	265.2	262.2		212.8	214.6	204.2	202.8	205.0
1952	278.2	274.8	271.9	274.9	271.8		218.8	221.0	212.8	210.1	214.3
1953	281.3	277.2	281.0	286.0	282.0		223.3	224.6	221.3	221.8	223.0
1954	285.0	278.2	293.0	300.6	295.4		219.6	219.1	223.5	225.2	225.4
1955	293.1	286.0	300.0	308.3	302.4		225.3	225.1	229.0	231.5	231.8
1956	310.8	302.2	320.1	328.6	324.5		237.2	235.7	241.7	244.4	246.4
Apr. 1957	316.5	306.5	329.8	341.8	335.4		239.4	237.7	245.2	248.3	250.4
May 1957	316.5	306.5	329.8	341.8	335.4		239.8	238.0	245.9	249.2	250.7
June 1957	316.5	306.5	329.8	341.8	335.4		239.8	238.0	246.1	249.4	251.6
June 1957	156.3	150.4	152.2	156.2	157.8		177.9	186.4	158.8	156.1	165.7

## ST. LOUIS

## SAN FRANCISCO

1930	108.9	108.3	112.4	115.3	111.3	90.8	86.8	100.4	104.9	100.4
1935	95.1	90.1	104.1	108.3	105.4	89.5	84.5	96.4	103.7	99.7
1939	110.2	107.0	118.7	119.8	119.0	105.6	99.3	117.4	121.9	116.5
1946	167.1	167.4	159.1	161.1	158.1	159.7	157.5	157.9	159.3	160.0
1947	202.4	203.8	183.9	184.2	184.0	193.1	191.6	183.7	186.8	186.9
1948	227.9	231.2	207.7	210.0	208.1	218.9	216.6	208.3	214.7	211.1
1949	221.4	220.7	212.8	215.7	213.6	213.0	207.1	214.0	219.8	216.1
1950	232.8	230.7	221.9	225.3	222.8	227.0	223.1	222.4	224.5	222.6
1951	252.0	248.3	238.5	240.9	239.0	245.2	240.4	239.6	243.1	243.1
1952	259.1	253.2	249.7	255.0	249.6	250.2	245.0	245.6	248.7	249.6
1953	263.4	256.4	259.0	267.6	259.2	255.2	257.2	256.6	261.0	259.7
1954	266.6	260.2	263.7	273.3	266.2	257.4	249.2	264.1	272.5	267.2
1955	273.3	266.5	272.2	281.3	276.5	268.0	259.6	275.0	284.4	279.6
1956	288.7	280.3	287.9	299.2	293.3	279.0	270.0	288.9	298.6	295.8
Apr. 1957	288.6	280.4	290.1	301.8	296.3	283.5	272.8	297.7	308.4	303.8
May 1957	292.0	283.6	294.4	306.8	300.6	286.7	274.4	302.7	315.6	309.6
June 1957	292.6	284.2	295.9	307.8	303.4	287.3	275.0	303.5	316.2	310.2
June 1957	165.5	165.6	149.3	156.9	155.0	172.1	176.9	158.5	159.4	166.3

Cost comparisons, as percentage differences for any particular type of construction, are possible between localities, or periods of time within the same city, by dividing the difference between the two index numbers by one of them; i.e.:  
 index for city A = 110  
 index for city B = 95  
 (both indexes must be for the same type of construction).

Then: costs in A are approximately 16 per cent higher than in B.

$$\frac{110-95}{95} = 0.158$$

Conversely: costs in B are approximately 14 per cent lower than in A.

$$\frac{110-95}{110} = 0.136$$

Cost comparisons cannot be made between different types of construction because the index numbers for each type relate to a different U. S. average for 1926-29.

Material prices and wage rates used in the current indexes make no allowance for payments in excess of published list prices, thus indexes reflect minimum costs and not necessarily actual costs.



speaking of 2-ball-bearing hinges...

**ONLY A HAGER  
HAS  
THE EXCLUSIVE**

*"Life-Time Bearing"*

**PERMANENTLY ANCHORED IN THE KNUCKLE  
WITH CASE HARDENED STEEL—NOT BRASS**

In the wear-away zone (zone of bearing anchorage) soft brass rubs steel in other leading hinges and they sometimes fail. Not so with Hager!

Hager's advanced, two-knuckle-bored construction puts steel against case hardened steel in this failure zone. The result is flawless ball bearing performance—life-time performance.

Yet you pay no premium for Hager's superior design and material. Compare and discover: Hager 2-ball-bearing hinges are unequalled in the industry!

*These same life-time features are also a part of the Hager 4-ball-bearing hinges.*

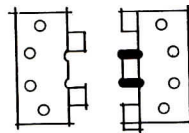
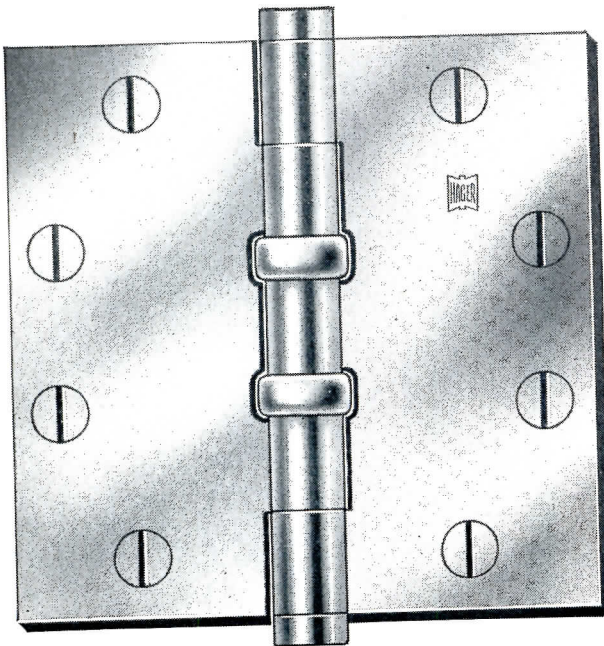

**NOT THIS ...**  
not one-knuckle-bored with wear-away brass to anchor the bearings. (Bearings finally fall out when pin is removed)

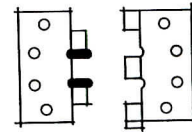

**BUT THIS ...**  
two-knuckle-bored construction with bearings anchored with case hardened steel.

**EXPLODED CLOSE-UP OF HAGER'S FAMOUS "LIFE-TIME BEARING"**

Brass outer shell permanently fixed. Protects raceways and balls from dirt. Contains lubricant in bearing.

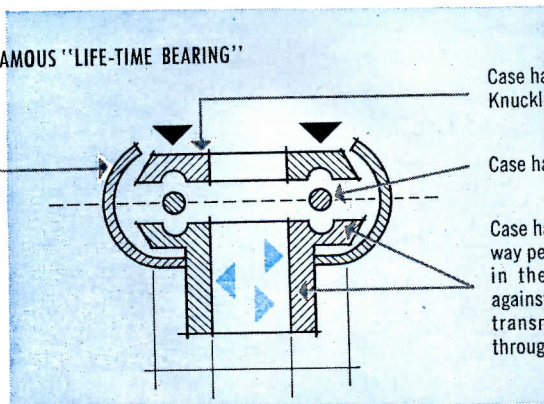

Case hardened steel top raceway. Knuckle rides on this.

Case hardened carbon steel balls.

Case hardened steel bottom raceway permanently fixed. Puts steel in the zone of lateral thrust against pin. Carries vertical thrust transmitted from top raceway through balls.



(Both stainless steel raceways and balls are available on stainless steel ball-bearing hinges.)



**EVERYTHING HINGES ON HAGER**

© 1957 C. HAGER & SONS HINGE MANUFACTURING CO. • ST. LOUIS 4, MISSOURI



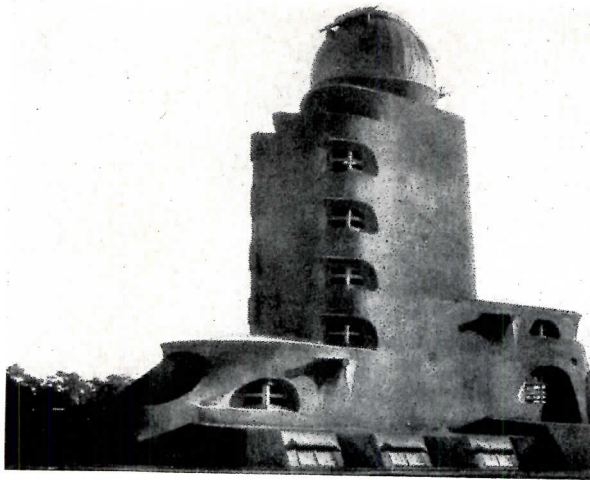

*Einstein Tower, Astro-Physical Institute, Potsdam, 1920*

*Eric Mendelsohn.* By Arnold Whittick. F. W. Dodge Corporation (N.Y.), 1956. 219 pp., illus. \$9.85

## A TIMELY REVIEW OF MENDELSON DESIGN

By H. H. WAECHTER, A.I.A.

THERE COULD BE no better choice of time for bringing to the fore again the name and work of Eric Mendelsohn. With older publications by and about Mendelsohn unavailable now, the new and enlarged edition of Arnold Whittick's book is filling a legitimate need. The publisher has done a fine job with this beautifully illustrated volume, showing a good cross section of Mendelsohn's work.

To this reviewer, the generous space given to many of the famous sketches is most significant. As Mendelsohn once said, "only the future requires prophets!" Despite the great inspiration which his executed buildings are imparting on us, the visions of his sketches will be of still greater importance in the years to come. The fluidity of his forms and the drama of expressive space are certainly parts of his imagination which will carry over into a time when our rectilinear modernism will be a thing of the past. The explanatory quotations from Mendelsohn's letters to his wife add much to the understanding of these sketches.

It is fortunate that pictures of the now destroyed hat factory at Luckenwalde

*(Continued on page 62)*

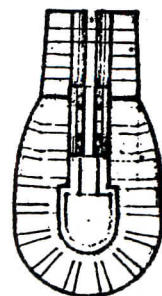

*Sketch and plan for optical factory*



**Spandrel Panels** formed from PLEXIGLAS provide functional beauty . . .  
lightweight . . . economy and low maintenance advantages.

**Daylight Louver Panels** . . . light transmission, daylight control and weather  
closure in a single formed sheet of PLEXIGLAS.

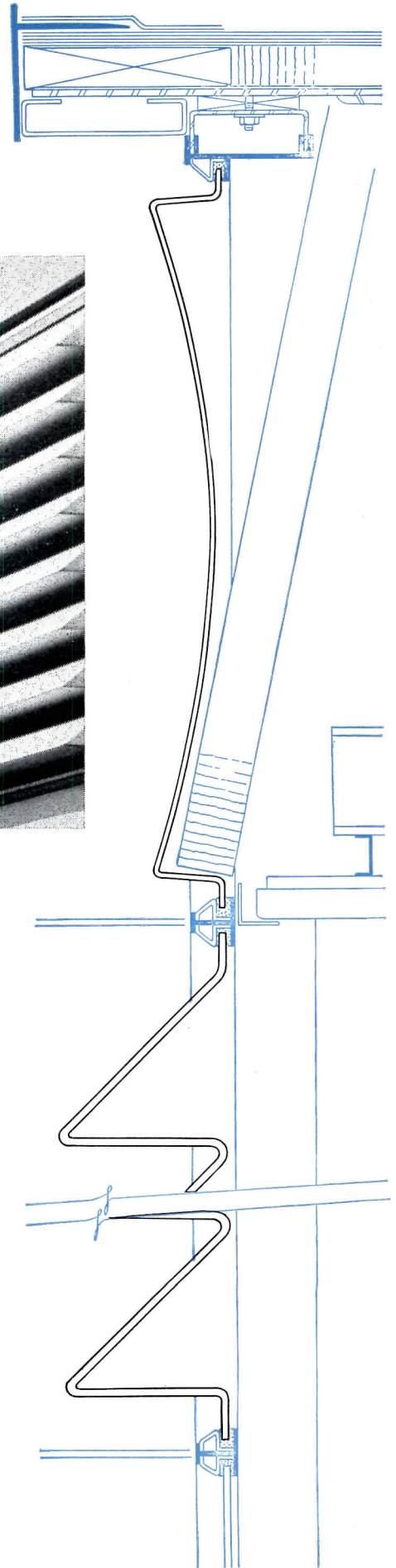
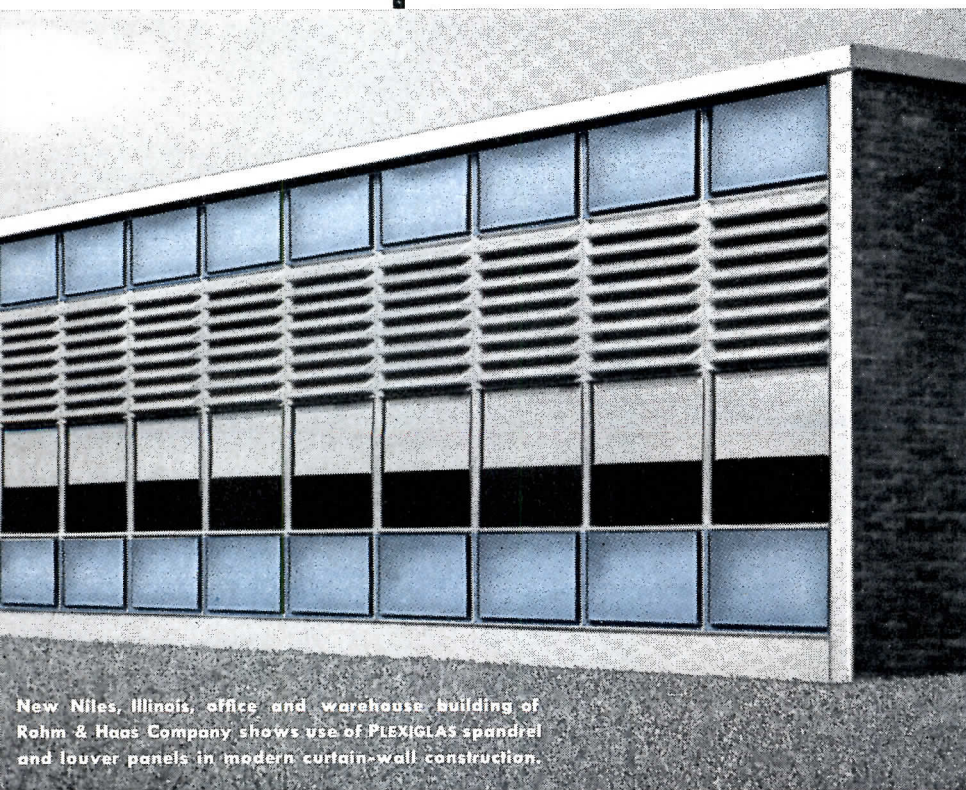
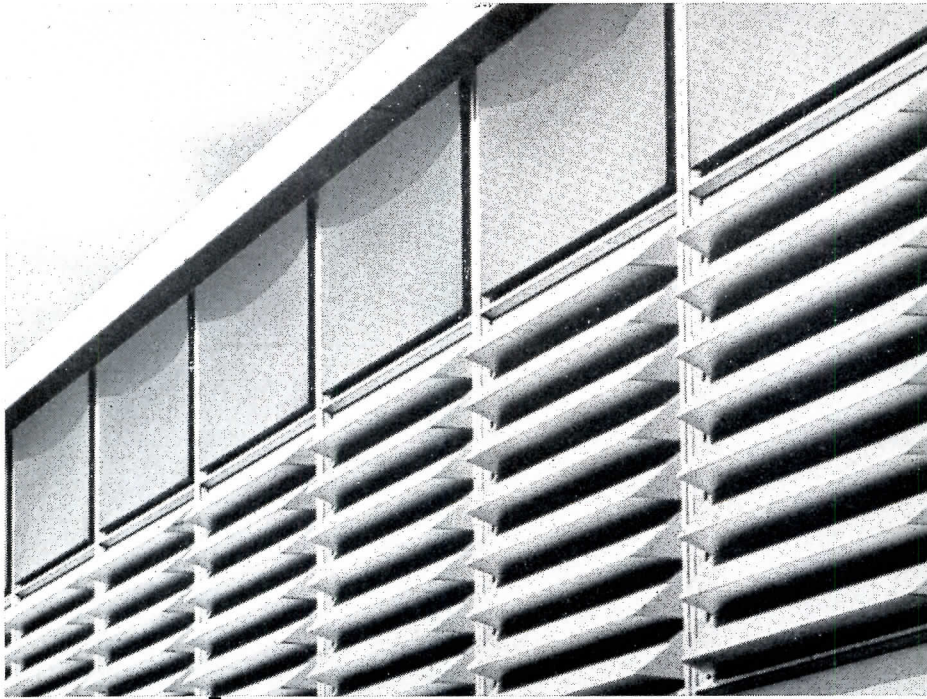

New Niles, Illinois, office and warehouse building of  
Rohm & Haas Company shows use of PLEXIGLAS spandrel  
and louver panels in modern curtain-wall construction.



REQUIRED READING

(Continued from page 58)

were included. Amazingly enough, such expressions of organic architecture are still evoking a stimulus of fresh beauty. Only today, more than thirty-five years later, an increasing number of young designers are being influenced by such ideas. Like the sculptured forms of the Einstein tower, the only built manifestation of his early sketches, the Luckenwalde factory with its angular shapes cannot be analysed in terms of functionalism and constructivism. This organic architecture is primarily an artistic interpretation of life's functions in harmony with nature. It seems significant to this writer that at the end of his career, Mendelsohn closed the cycle of his development by returning more or less to the dynamic visions of his youth, but rarefied with fine lyricisms and the serenity of mature age.

Mr. Whittick is giving a pocket-sized historical roundup of European architecture in his introductory chapter. Suspecting the usual build-up of the hero, one is surprised to find the anticlimactic statement that Mendelsohn can hardly be regarded as one of the pioneers of the new architecture, but rather as one who has combined the experiments of his forerunners. However, Gropius is Mendelsohn's senior by only four years and cannot very well be considered a forerunner of Mendelsohn. Whittick's study actually testifies to what this writer would consider a historical fact, namely, that Mendelsohn was a great exponent of that generation which initially signaled the profound changes which were to come within Western civilization in the wake of two world wars and several social uprisings. Quite typical for him, in this atmosphere of disintegration he rallied all his strength to find order and inner serenity in his work by contrast to eccentric stimulation and the inflation of standards of life which are so characteristic of this century of material productivity. It did not suffice for him to take the cut and dried suggestions of industrial standardization. In fact, he felt the chill of rationalistic doctrines.

Mr. Whittick's book deals in a chronological fashion with Mendelsohn's development and work. The writing is very enjoyable, somewhat conversational in character, and thus done at the expense of completeness and exactitude.

(Continued on page 400)

**IT PAYS TO HAVE GOOD CONNECTIONS**

**ST. XAVIER LIBERAL ARTS HIGH SCHOOL**  
Chicago, Illinois

**ARCHITECTS-ENGINEERS**  
Noess and Murphy

**ELECTRICAL CONTRACTOR**  
Emerson Comstock Co., Inc.

**HUBBELL SUPPLIER**  
Englewood Electrical Supply Co.

1000" 1.312"  
1.046"  
2.437" 3.281"  
2.375"  
#6-32 TAP

Dependable AC switch control is of vital importance in any fluorescent lighting installation where high levels of illumination require a large number of fixtures operated at full rated capacity. As in the beautiful school plant above, Topper AC quiet action switches are the ideal choice because they are designed to control many more fixtures than conventional switches, thus permitting control of *more fixtures with each switch*. Operation of heavier circuits (and fewer of them) results in lower wiring costs. Remember, too, that Topper switches are shallower, take up less room and are easier to install.

Detailed information on request

Cat. No. 1221  
20 amp.  
120-277 volt  
AC Switch

**HARVEY HUBBELL, INC.**

BRIDGEPORT-2, CONNECTICUT

QUALITY WIRING DEVICES

**FACTORY WAREHOUSE LOCATIONS ASSURE NATIONWIDE STOCK AVAILABILITY**

Bridgeport 2, Connecticut  
State and Bostwick Streets

Chicago 7, Illinois  
37 South Sangamon Street

Los Angeles 12, California  
103 North Santa Fe Avenue

San Francisco, California  
1675 Hudson Avenue

Dallas 7, Texas  
1111 Dragon Street



# AN EDUCATIONAL OASIS

ARCHITECTURAL RECORD SEPTEMBER 1957

In this elementary school the individual classroom is an incident in a garden walled off from the community. While the educational symbols in this kind of segregation may be debatable, the architectural potentials appear uniformly rewarding. The *contained* courtyard is familiar to us in school planning, but the *containing* courtyard offers a total inversion of the court-classroom relationship. Here the "space between" becomes the primary fact.

Architects Charles R. Colbert and Mark P. Lowry describe the proposal as "a school placed in a large wooded tract of land which serves as a protective screen to isolate, both physically and spiritually, the educational function from the world without. Dominant forces in the learning process are experience and physical association. With this in mind, a series of gardens, plazas, and courts has been created to isolate and amplify certain phenomena, sensations, human emotions, and fields of thought."

The emphasis on isolation may prove alarming as an educational idea, but as an architectural fact, the school is no less accessible than any other. The suggestion of restriction in the selection of organized experiences may frighten some but is not basic to the architectural concept, which actually provides an opportunity for an almost infinite variety of experience. The treatment of the courts and their walls will be limited only by curricular intent and parent participation in furnishing constantly changing exhibits.

The classrooms are dimensionally and structurally standard units, but their disposition within the garden offers a completely new outlook as the child moves from one room to another. In a time much occupied with motivation, everything here is calculated to ward off monotony. The architects want the children to get out into the weather on their trips to the washrooms and the lunchroom. In a less rigorous approach the inclusion of covered walks would hardly destroy the architectural idea; nor would overhangs, nor entrances less bizarre than the proposed culvert. All details here are subordinate to the great and welcome idea of standard units set about in a walled garden in which the open spaces may be treated and used positively in a constant *do-it-yourself* program for teachers and pupils.



*Charles R. Colbert, A.I.A., Architect-Planner; Mark P. Lowry, Senior Associate; William J. Hess, Jr., Assistant*

**SPACE ENCLOSURES**

1. Kindergarten
2. First Grade Classroom
3. Second Grade Classroom
4. Third Grade Classroom
5. Fourth Grade Classroom
6. Fifth Grade Classroom
7. Toilets
8. Storeroom
9. Activity — Cafeteria
10. Kitchen
11. Administration (Over)

**COURT YARDS, PLAZAS AND GARDENS**

12. Court of Sound and Music
13. Court of Anagram and Alphabet
14. Council Plaza
15. Orchard Terrace
16. Clover Lawn
17. Sunken Court of Anthropology and Geology
18. Sunken Gardening Area
19. Animal Enclosure
20. Frontier Court
21. Biological Garden
22. Light and Color Plaza
23. Grass Theater
24. Fairyland Plaza
25. Water Source and Fountain
26. Court of Numeral Logic
27. Loggia of Theology
28. Court of Astronomy and Time
29. Courts of Techniques
30. Sculpture Arbor

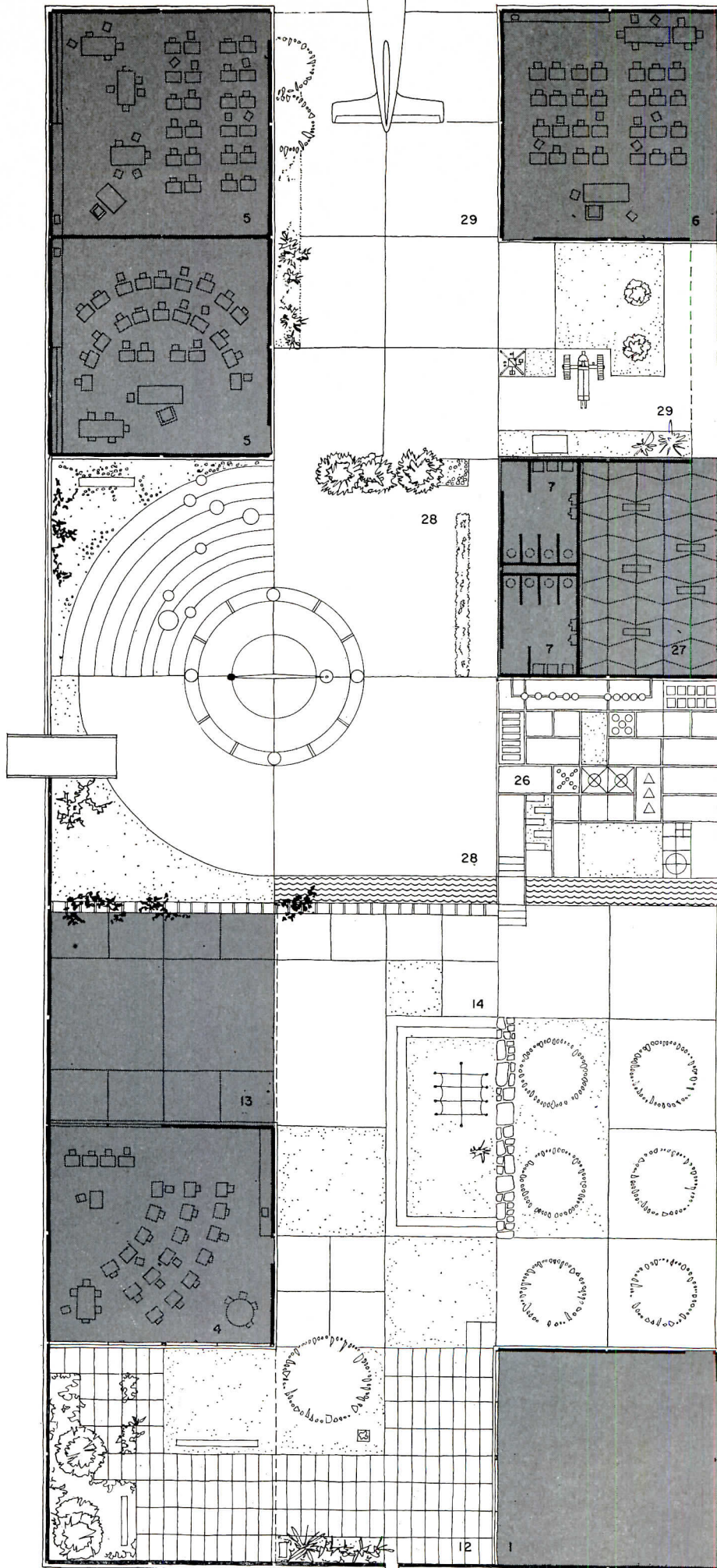



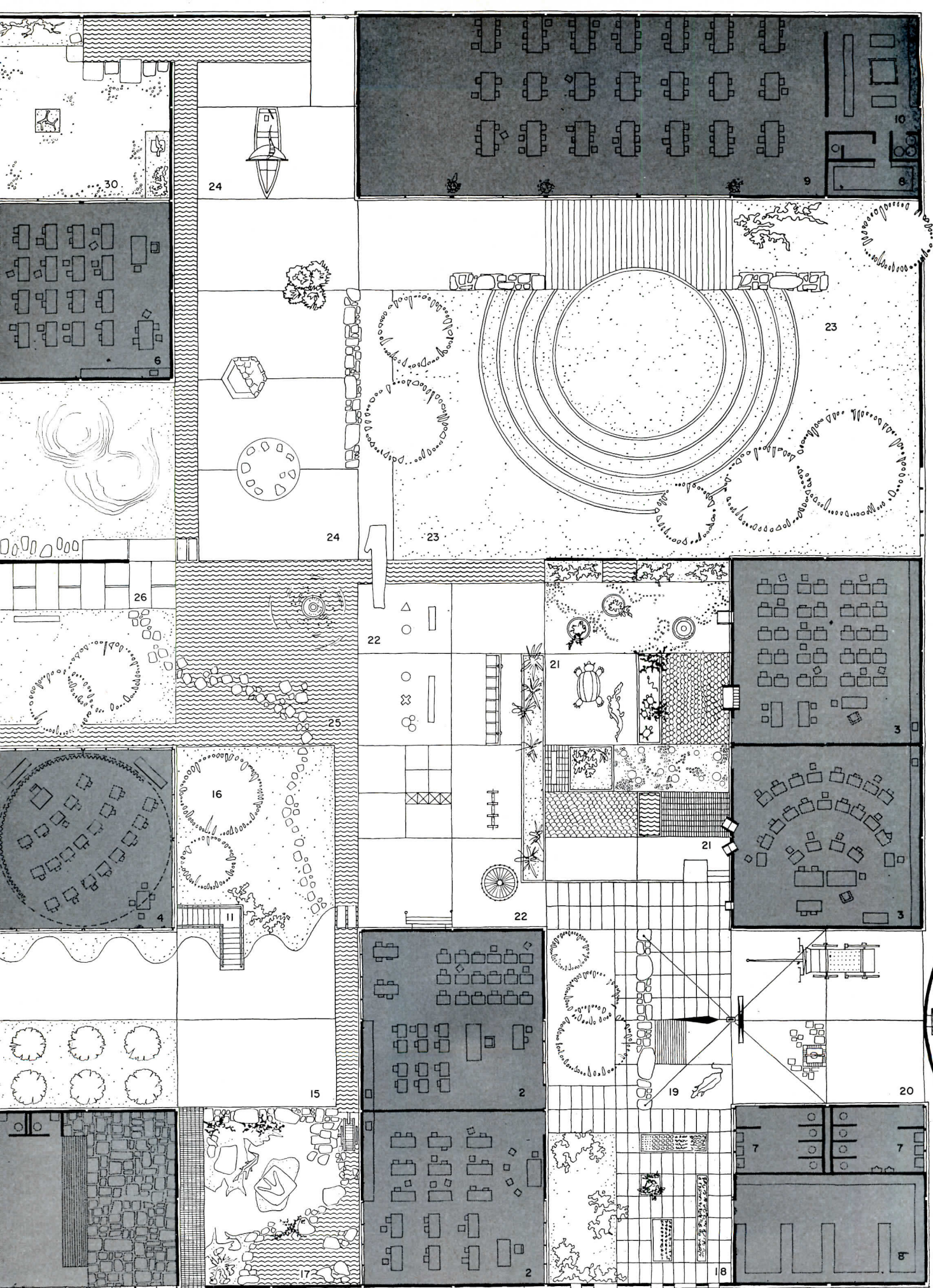



Entrance to the school beneath the wings of an airplane or through a large section of concrete pipe is suggested as typical of the romance which could be engendered in a school which presents no façades to the outside world and permits the greatest latitude in the expression of an oasis character independent of the actual means of entrance used

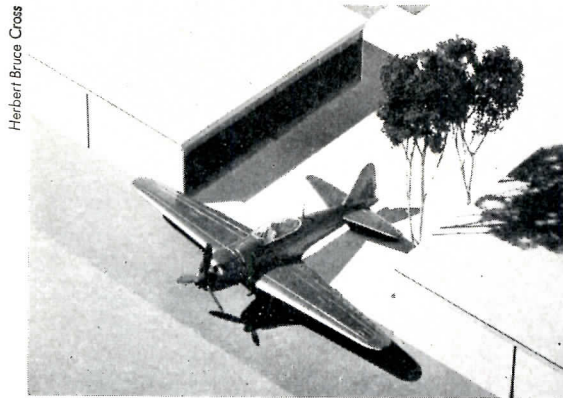

Herbert Bruce Cross

Herbert Bruce Cross

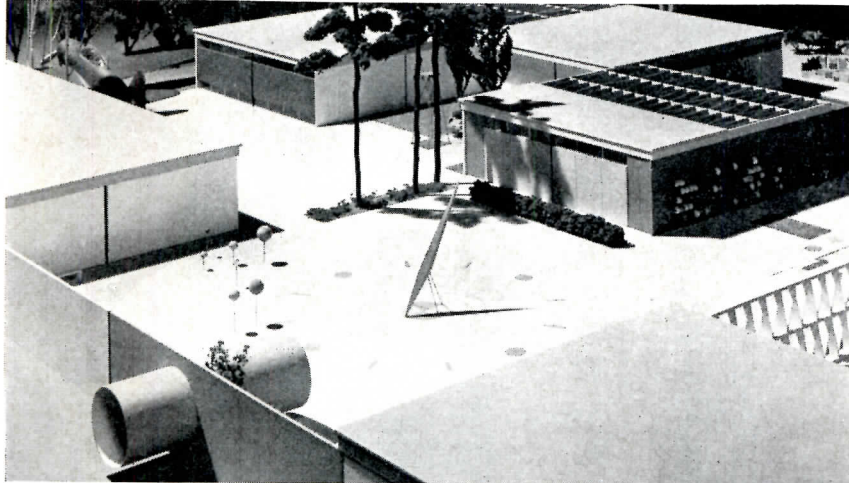

Both of the entrances shown at left lead directly into a "Court of Astronomy and Time" in which a large sun dial is the principal feature. Atop the pylon is a melodious, hand-operated signal bell. On the wall at rear right a giant, colorful abacus is mounted for use of the very young pupils

Narrow watercourses extending in all directions from the central pool divide the walled garden into quadrants. In the lower right area all children gather in the cafeteria and in the open-air theater alongside. Lower left is for first and second grades; upper left for kindergarten and third grades; upper right for fourth and fifth. Children may be generally restricted to their own areas so that the manifold garden exhibits and experiences may be measured out over their six-year life here. Administration offices are in the only two story structures adjoining central pool

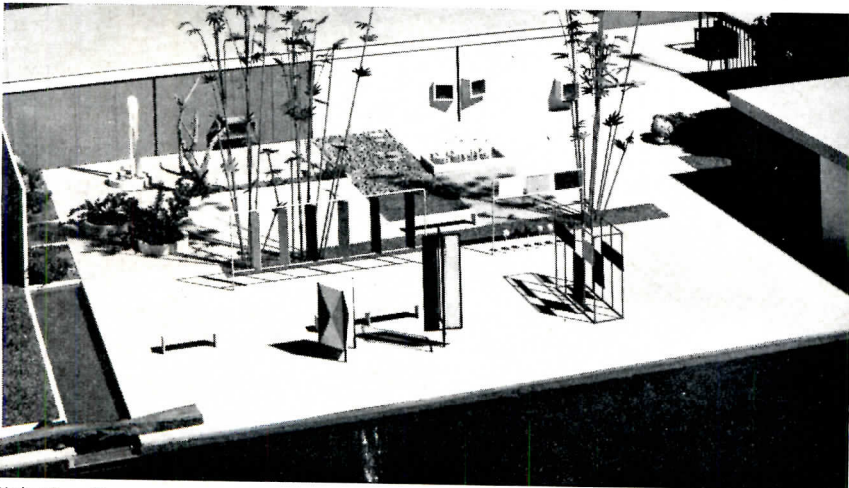

Herbert Bruce Cross

Between the pool, outdoor theater and first and second grade areas is a Light and Color Plaza where "color from the spectrum and color from pigments are related in educational devices continued to exploit their characteristics." Wheels and superimposed frames demonstrate the basic principles of refraction, supplement and complement. Trees here and throughout garden are selected and grouped for appearance during the four seasons and as illustration of botanical variety



Joseph W. Molitor





Theatrical facilities are limited to the outdoor area between Light and Color Plaza and cafeteria. Of this provision the architects say, "Going barefoot in a clover patch is a long-remembered experience." The Grass Theater provides a location for assembly, outdoor productions, and passive recreation where children may enjoy the feel of clover between their toes. The performing area may be extended back into the cafeteria whose curtained glass wall can act as a proscenium and provide screened wings for some elaborate productions

Herbert Bruce Cross

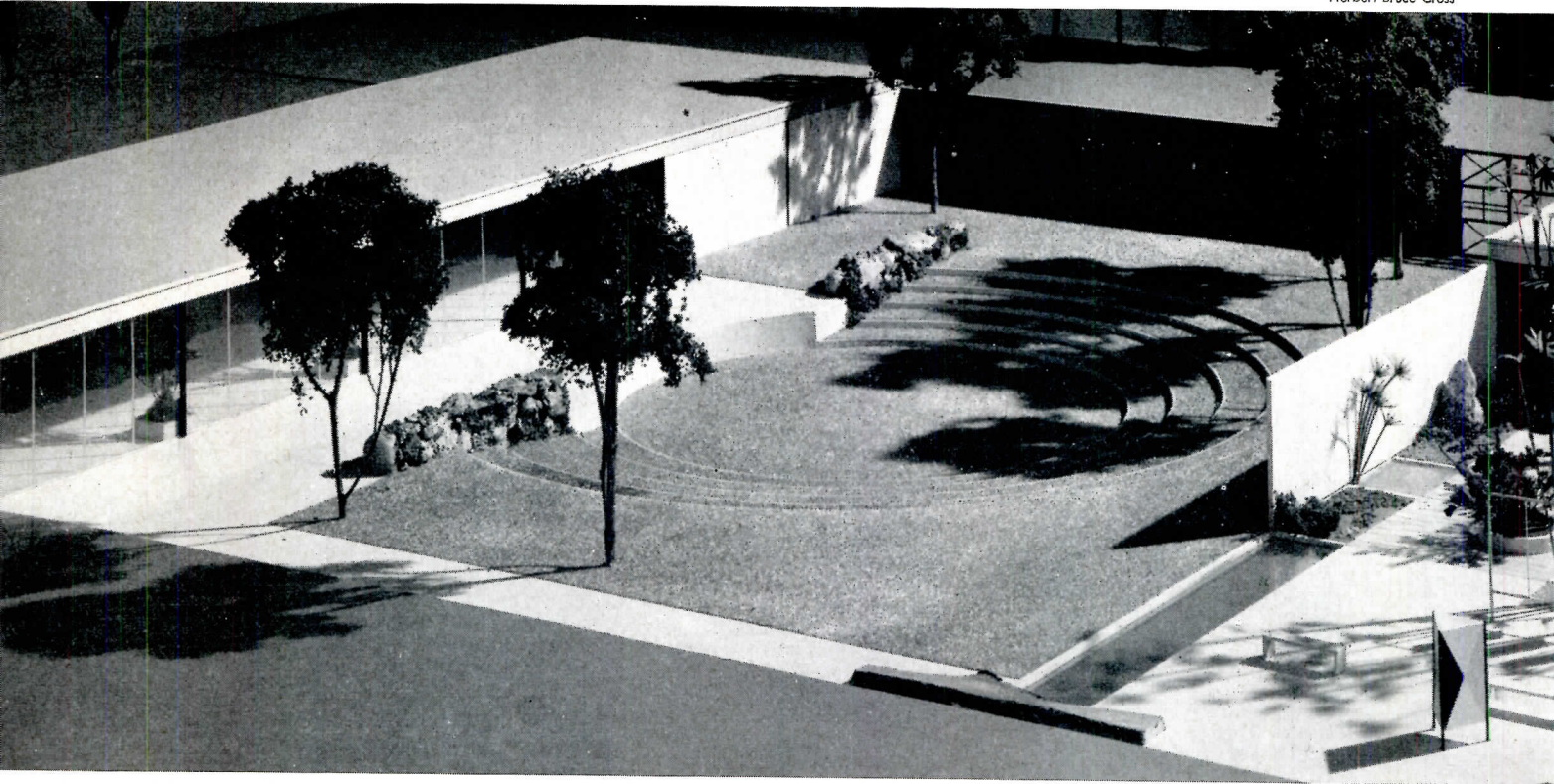

Entrance to first and second grade area is through a Frontier Court featuring a stagecoach, an oaken bucket well, a windmill and an animal enclosure where single animals will be housed for short periods to afford close range observations. Basketball hoop with curving back wall illustrates small emphasis placed on organized athletic facilities which may not be necessary for this age group but which could be incorporated easily in the flexible arrangement of building units

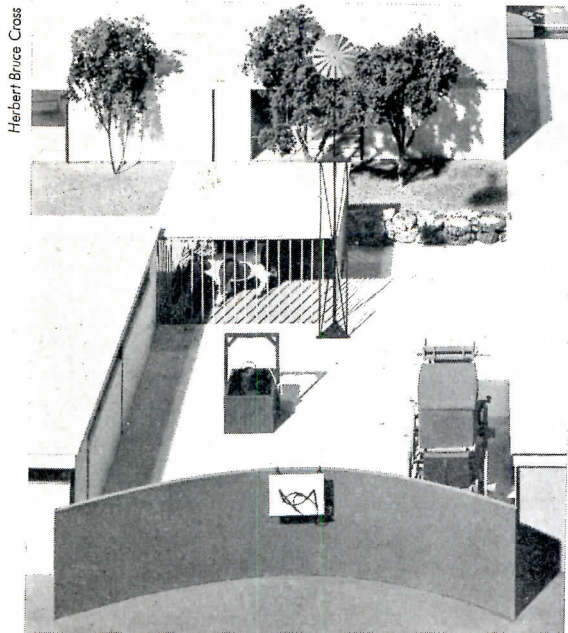



## OASIS

Herbert Bruce Cross

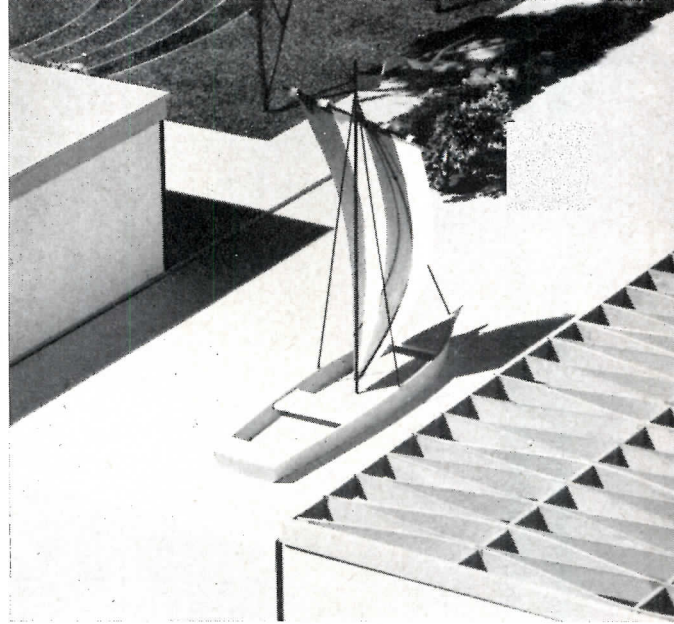

In the plaza adjoining the cafeteria and outdoor theater the architects suggest use of a group of simple abstractions of objects recalling adventure. In the imagination of the children "the boat" can be Prince Valiant's barque, the Santa Maria, a Pirates' gallion or Ahab's whaler. The arbor at right shelters a Sculpture Garden

Behind the Light and Color Plaza are the outdoor theater and cafeteria at left, the second grade classrooms at right. These are windowless and afford children only selected visual experiences through limited vision view boxes. In contrast the third grade is housed in a "glass box." While neither are essential to scheme they are typical of motivating philosophy

Joseph W. Molitor





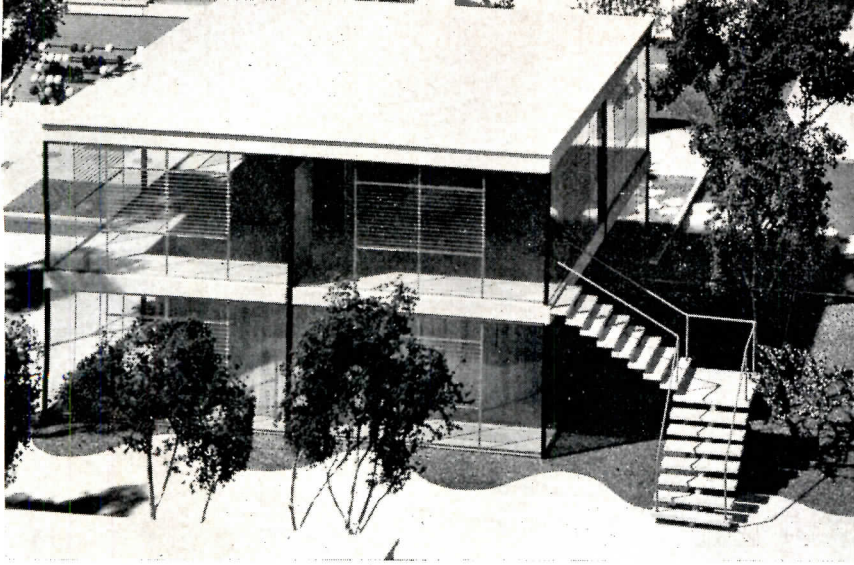

Herbert Bruce Cross

Administrative offices are located above the third grade classrooms whose four walls here are entirely glass. In second grade the children are entirely removed from the outdoors in order to establish maximum change and emphasis in visual stimuli

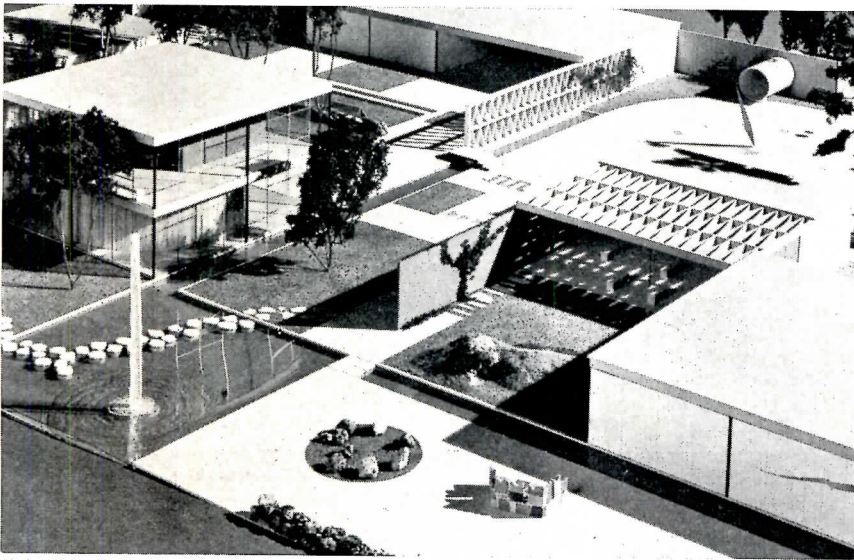

Herbert Bruce Cross

All structures are designed on a four-foot module and to be carried out in steel-and-plywood. Nowhere are there overlays or covered walls although there are occasional arbor-covered areas as seen below in the Sculpture Garden and the Loggia of Theology behind it

Herbert Bruce Cross

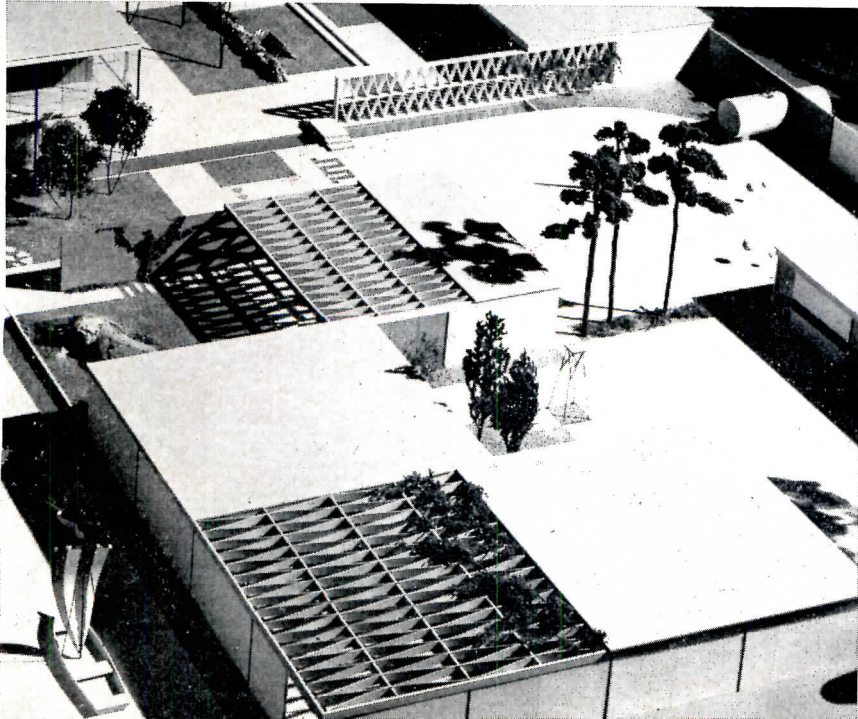

At the center of the "oasis" water is an appropriate symbol and tool. A central water jet feeds sluiceways and reflection pools. Smaller groups of jets are proposed elsewhere as "psychological aeration points" and produce a misty coolness below the tree groups. Waterwheels, miniature watercourses, lily ponds, and aquariums are fed from the same source of recirculated water





Although it is not basic to the planning principle set forth in this school the use of a rigorous spatial and structural module is a natural and useful by-product. The enclosing wall of the garden provides a unifying dominant which permits great flexibility in positioning the classroom units and almost complete freedom in the choice of wall panel types for various classroom purposes and orientations. In the above picture the fourth grade classrooms are on the right, the fifth grade on the left. This view is from the airplane entrance and looks at the Court of Astronomy and Time in the middle distance



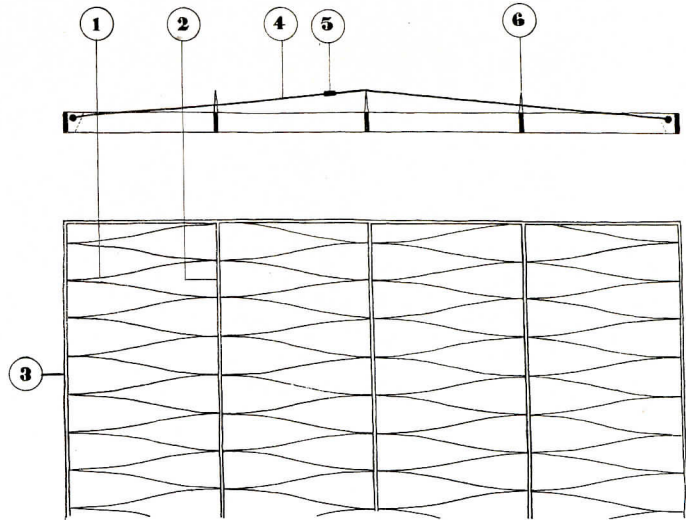
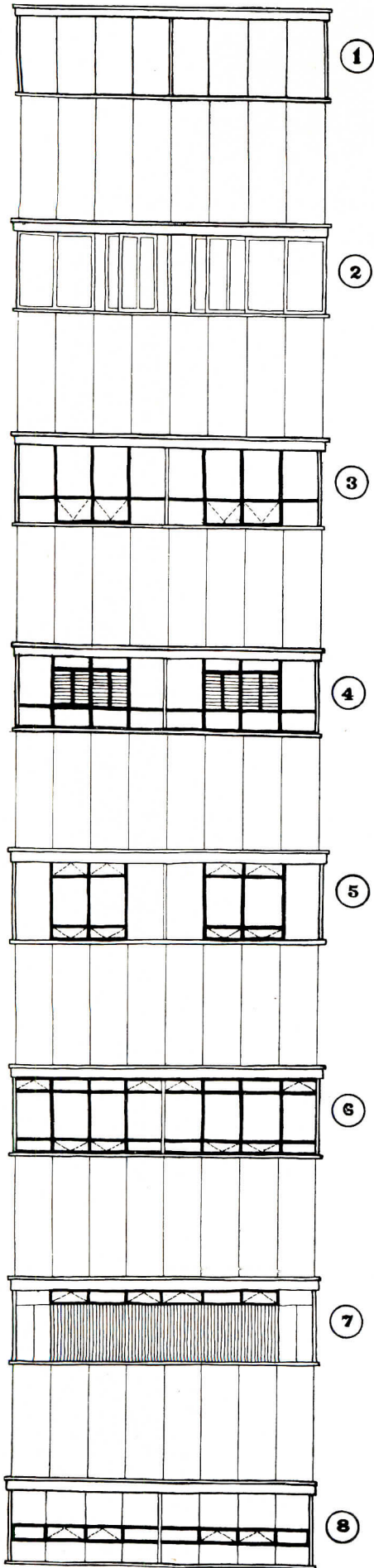

In this proposal plywood is employed as the principal building material. In the drawing below an expanded plywood roof system of continuous  $\frac{5}{8}$  in. ribbon joists (6) with 2 by 12 block spacers is supported on a light steel frame of columns (2) and (5) and angles (3). Slab floor (1), insulated plywood wall panels (4), and a built-up roof (9) over rigid insulation (8) and plywood sheathing (7) makes up typical unit which employs a space heater (11). For heavier loading conditions the optional trussing section, above, uses stressed cables with turnbuckles and trussing struts

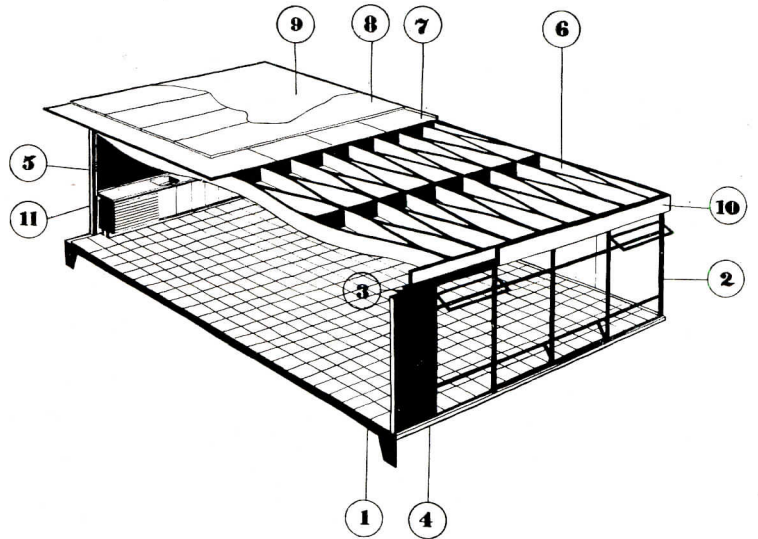

Wall panel combinations shown at left provide a full range of possibilities from the solid insulated panels (1), to panels with vision strip (8); (2) and (3) show full length sliding glass doors and full length glass with hopper windows; (4), substitute louvers in the full glass wall; (5) and (6) use combinations of vented glass and panels and (7) shows entrance panels in combination with solid walls





MAN MADE THE BUILDINGS





All photos by Morley Baer (including p. 177)

**MARK THOMAS INN, MONTEREY, CALIFORNIA**

*Architect: John Carl Warnecke. Landscape Architect: Laurence Halprin. Interior Designer: James Aldrich. Mechanical Engineers: Clyde Bentley*

HOW TO DESIGN buildings for sites of overwhelming natural beauty is not one of the main concerns of contemporary architectural study. Probably, in any case, this is not a topic for academic discussion; one could approach it only by specific example. And where a better example than this one? Man made the buildings here; man also added several contrivances to the site. But man was inspired to throw away the book and follow unabashedly the call of a great gift of beauty. And if this course seems one of self-abnegation, well, man won a national A.I.A. award of merit for the first stage of this building operation (page 182), and another for the second stage, including the restaurant (above).



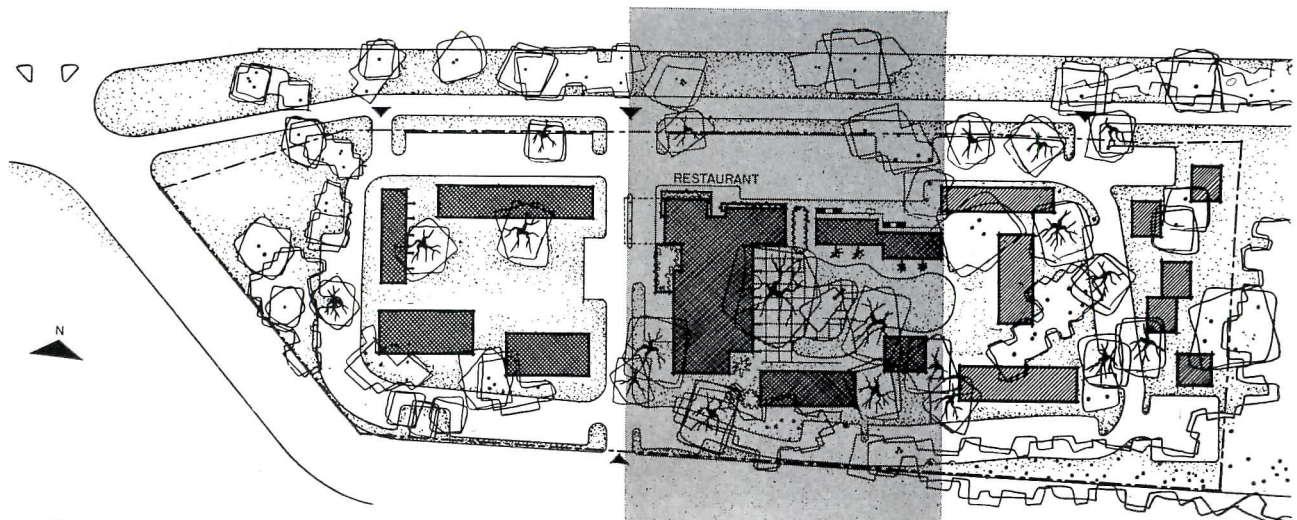
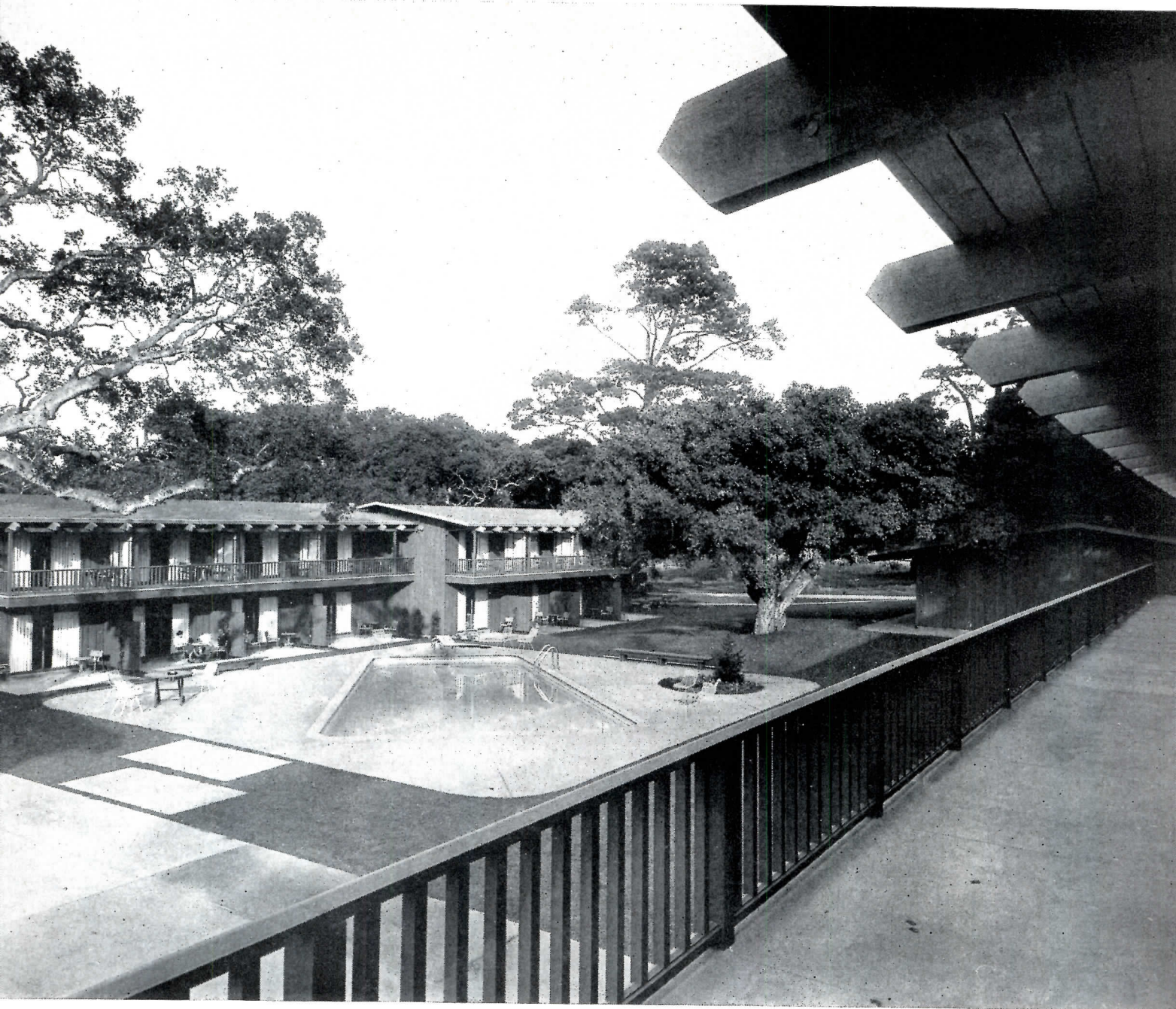





As for the architect's motivations, he writes simply: "The site was developed to fit the buildings, roads and parking areas into the open spaces between the old oak trees. The architectural organization and style are deliberately casual and subdued to harmonize with the character of the wooded site. The wooden structures are quiet; parked cars are not allowed to intrude; the design seeks to subordinate the structures to the great beauty of the land forms and the trees." The buildings shown above (also page 179) add 28 luxurious hotel units. These, with the restaurant building, form a second-stage group around the swimming pool; a third group is contemplated for future development. Dining and bar facilities now completely fit the inn for convention or meeting use, as well as the normal resort custom.



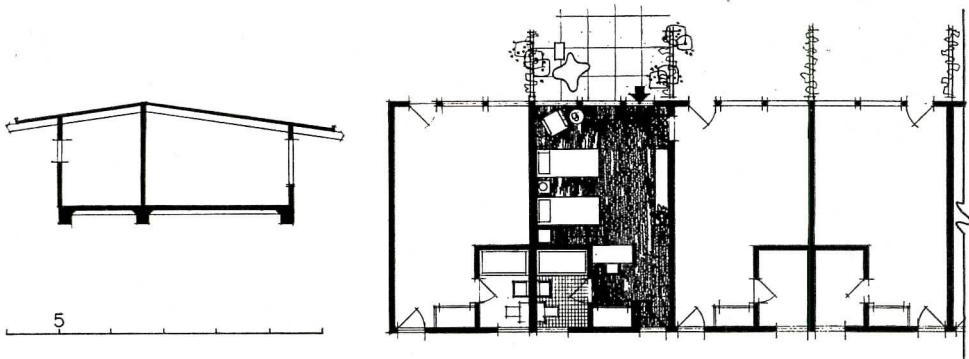



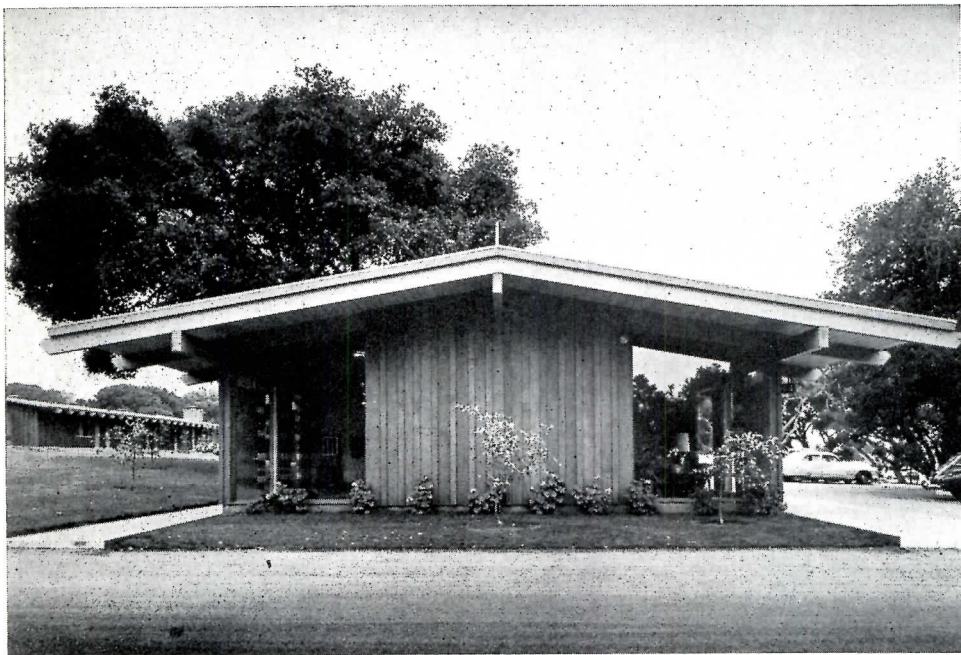
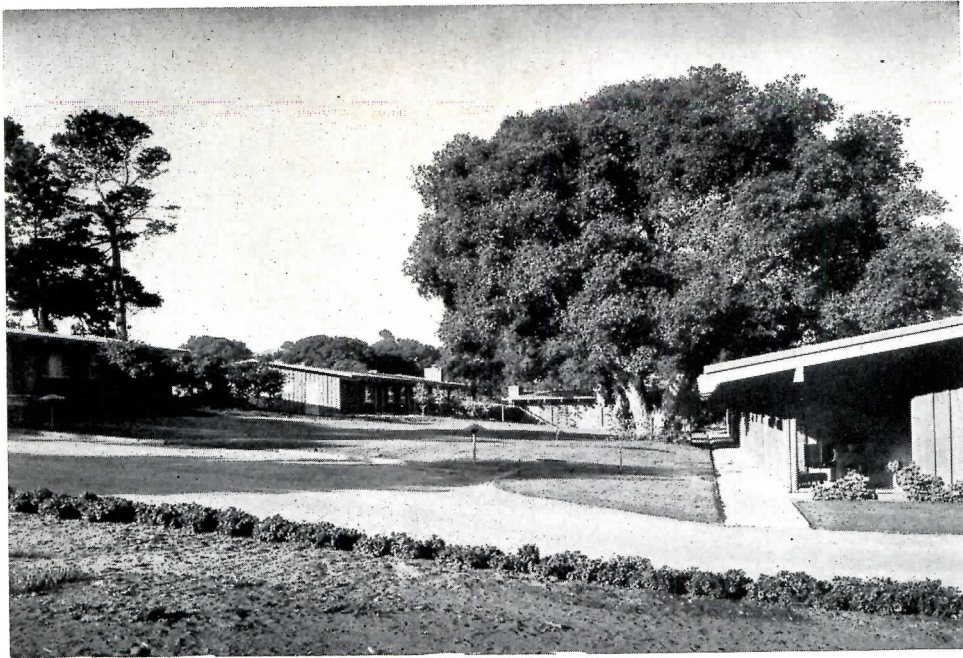

This first group rather established a style for the later buildings, though the success of the first made the second a bit more luxurious. Construction is concrete slab on gravel, board and batten side walls, plank roof on 4 by 10 beams, plywood interiors.

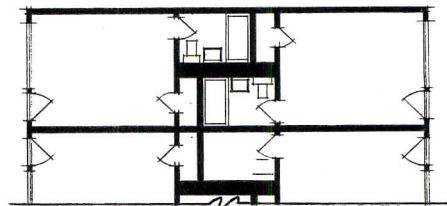
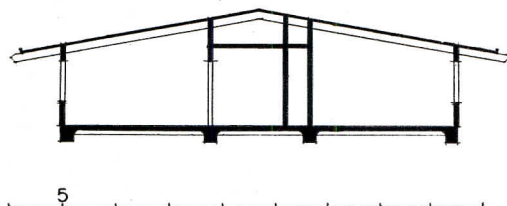



The author, viewing with fresh alarm, classifies decoration as:  
**1 Applied      2 Insinuated      3 Invited**  
roughly in the order of their offensiveness to him

## DECORATION RIDES AGAIN

By ROBIN BOYD

*Ornament should appear, not as something receiving the spirit of the structure, but as a thing expressing that spirit. . . . A decorated structure, harmoniously conceived, cannot be stripped of its system of ornament without destroying its individuality.*  
— LOUIS SULLIVAN

WITH THE LEAST possible historical research I am able to quote the above words, for they appear, along with other statements on ornament and organisms, on the wall of the Sullivan memorial exhibition which is presently touring the country outbound from Chicago. Here is an unequivocal statement in the old master's best form, and any interested layman who has visited the exhibition doubtless began thinking as he read it, standing among the bronze grilles and decorative samples displayed between the architectural photographs. And the train of thought begun by this nostalgic show, with its emphasis on ornament, probably ran on as he stepped out of the gallery and observed the sunlight glinting on the patterned metal panels of the curtain-walling on some new office building across the street. The thought will stir again when he sees the mural-lined lobbies of some new buildings, when he brushes past their sculpted screens, and when he hears the new calls for the introduction of painting and sculpture into architecture. Eventually he is likely to be led to the conclusion that the plain, unadorned building of recent years was (as he always guessed) a fad, a fashion whose days are numbered. Ornament is returning: check your investments.

Being an alert fellow, however, the layman perceives that the new ornament is not the sort of thing that he remembers in the Victorian parlor or the modernistic movie palace. He sees that if building adopts a rational basis and abnegates the special construction of non-functioning and non-structural parts, then there can be only three guises for ornament, three ways in which it can ride its vehicle architecture:

*By application:* fastening itself to the surface of the forms.

*By insinuation:* decoratively shaping parts which are required anyway.

*By invitation:* in the guise of what is commonly de-

scribed — to distinguish it from architecture — as “art”; that is, any painting, sculpture or so forth with a meaning of its own.

Now, the first of these guises may be dismissed. The new ornament (the layman realizes) is not like the old kinds. It is in the best possible taste. The idea of gluing on decoration is unthinkably trite. Ornament must enter in the second or third guise. It must be integral, organic, a part of the conception of the building; either the tasteful patterning of some material which has been specified already, or “art” magnanimously invited by the utilitarian structure to occupy a prominent position. Thus one should understand that the present revival of ornament represents no turning back on the principles of simplicity introduced by the modern movement; it is merely a more enlightened interpretation of those principles.

But the disconcerting thing about these comforting arguments of the day is that they have been used before, and to justify unspeakable vulgarities and crass absurdities in the most sordid depths of architectural practice. No architect ever seriously suggested that ornament should be added to a building design already complete in itself. The designer of the fussiest Victorian façade felt his creation was not complete until he added the last horrible piece of adornment; to strip off any would be to destroy some subtle quality, some *je ne sais quoi*, which he had carefully “conceived-in” and nursed to completion.

The anti-ornament ethics embodied in the early denunciations of decoration by Horatio Greenough (“the instinctive effort of infant civilization to disguise its incompleteness”) and Adolf Loos (“evolution of human culture implies the disappearance of ornament”) were not concerned with the casual commercial decoration. They were aimed at precisely the sort of self-righteous ornament which is now being revived and revered. The old rebels meant what they said when they asked architects to abandon the savage urge. When they talked of simplicity they seriously meant plainness, believing that architectural forms and spaces should be designed self-sufficient, using materials explicitly, to be complete in themselves.



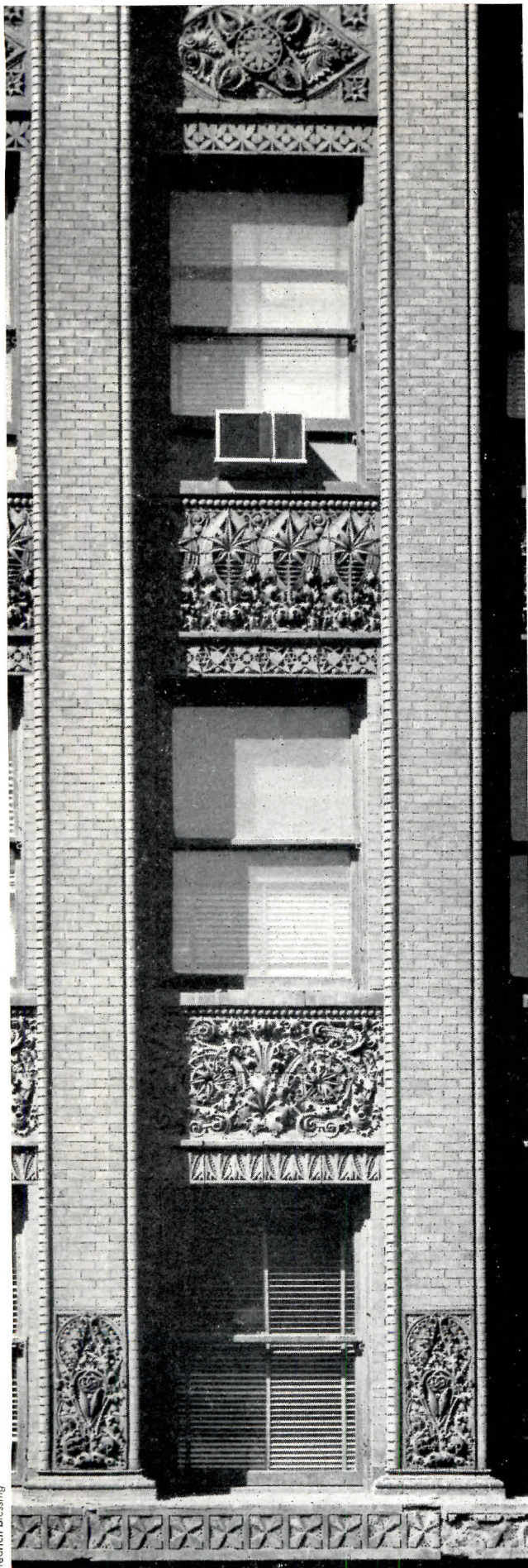

Heinrich-Blessing

*APPLIED.* Louis Sullivan decorated his buildings (Wainwright) "because he could not resist fondling his materials, like any happy craftsman, but he knew it was only a side issue."

While this philosophy is still widely if not universally accepted by the architects, the unfortunate thing is that in practice it frequently leads to a box of infinite dullness. The question today, then, is whether we should toss out the philosophy or the way it is most frequently practiced. These are the alternatives if the richness which everyone seems to desire is to be returned to building.

Thus it is significant at this time that the aspect of Louis Sullivan's work which was featured in his memorial exhibition was his affectionate ornamentation.

It is significant that the Museum of Modern Art, displaying Edward D. Stone's U. S. Embassy design for New Delhi among six outstanding "Buildings for Business and Government," chose to feature a lifesize section of the ornamental terra-cotta grille which surrounds the building.

It is significant that the Museum's catalog of the same show should have said:

*Sculpture and painting have not become as much a part of modern architecture as many people would like them to be. Merely to install a sculpture, however large, is not enough. Its successful relation to the building, unless it is structurally self-evident, must depend on the exact coincidence of the architect's and the sculptor's intentions.*

Heaven forbid that I should suggest any impatience with the Sullivan grilles, Mr. Stone's terra-cotta or the idea of introducing sculpture and painting. I merely remark that it seems significant that a rather hoary, weighty, defeatist attitude to architecture, typified by these three incidents, should be rising to the rarefied air at the top of the modern movement; it is simply that one begins to wonder what happens to a movement when its avant-garde turns back to other arts for help. These approaches to Sullivan, Stone and sculpture represent the three alternative approaches to adornment, and if we are seriously thinking of re-admitting ornament we might briefly consider them in turn.

Most of the Sullivan's ornament was not, for all his protestations, an integral expression of the spirit of his building forms. It was separate, a sensitive artist's gift from the heart to a building he loved. Mostly it remains like a cherished gift on the mantleshelf, a handsome acquisition made so much nicer by the fact that it was not expected nor really necessary. Sullivan made ornaments because he could not resist fondling his materials, like any happy craftsman, but he knew this was only a side issue. "It is not evident to me," he admitted, "that ornament can intrinsically heighten [architecture's] elemental qualities." He was first and always an architect, and accepted a rational basis for architecture. In doing so he voluntarily restricted his ornament to the three guises: application, insinuation, invitation



*INSINUATED.* Edward D. Stone's grille for the New Delhi embassy design, "is an admission in the second guise . . . the architect is to be congratulated on keeping the pattern so restrained."

Since the ornament he liked had no separate non-architectural meaning it was not in the third category of invited art. But he was apt to use either of the other guises. Sometimes (e.g. in the Wainwright Building) he insinuated ornament; sometimes (Carson, Pirie, Scott) he applied decoration which would be just as fascinating if it were unhooked and displayed in the museum. A lot of it was, in effect, unhooked and shown at his memorial exhibition, where it had nothing to do with architecture.

The terra-cotta grille for New Delhi, on the other hand, is an admission in the second guise, like the cups and darts and diagonal dents in the metal panels of some new office curtain walls. It is one of a number of Eastern-Western devices in a sharply formed, imaginatively textured building where the twain may meet. Each terra-cotta block is pierced to leave a quadrant in silhouette and they build up together in the wall to produce a fetching combination of circles and rectangles, with that distinctive inter-racial quality of an Indian movie poster. The screen itself is an important part of the formal conception inasmuch as it presents, while shading the glass, a continuous surface for the free-standing, gold-colored steel columns to play against.

Since technology has not yet provided anything better to fill the long-felt want for a sun-sieve of this sort, terra-cotta block was a practical choice for the job. And since terra-cotta blocks are amenable things, the architect is to be congratulated for keeping the pattern so restrained. There can hardly be doubt, however, that an even more restrained pattern would throw more emphasis on the form of the building. This is the basis of the objection to all adornment that slips into rational architecture in either of the first two guises. Any patterning may be admitted if it pleases the architect and if the material falls easily into the shape — by all means let us not invoke "moral" laws — but the patterning is at best inconsequential and at worst in distracting from the enjoyment of the form. The screen at New Delhi may not turn out to be distracting, but featuring it at full-size in a public exhibition must have diverted a sizable amount of lay interest from the architectural essentials.

Now consider the third guise, the invited art work, and the Museum of Modern Art's catalog statement. "Merely to install a sculpture . . . is not enough," it said. "Its successful relation to the building . . . must depend on the exact coincidence of the architect's and the sculptor's intentions." Then it added: "As an alternative the architect may execute the sculpture himself, as Mies van der Rohe proposes to do for the Seagram building." I submit that all this is precisely the way *not* to introduce art into architecture. The art re-

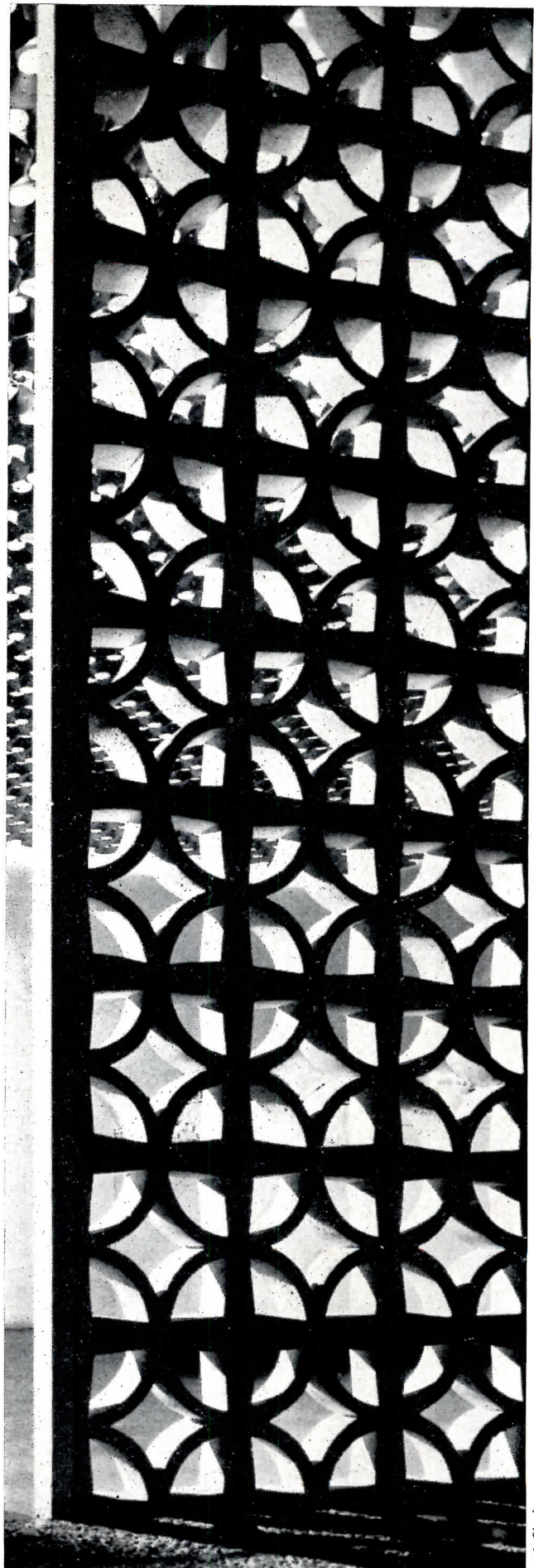

Lewis Cleckman



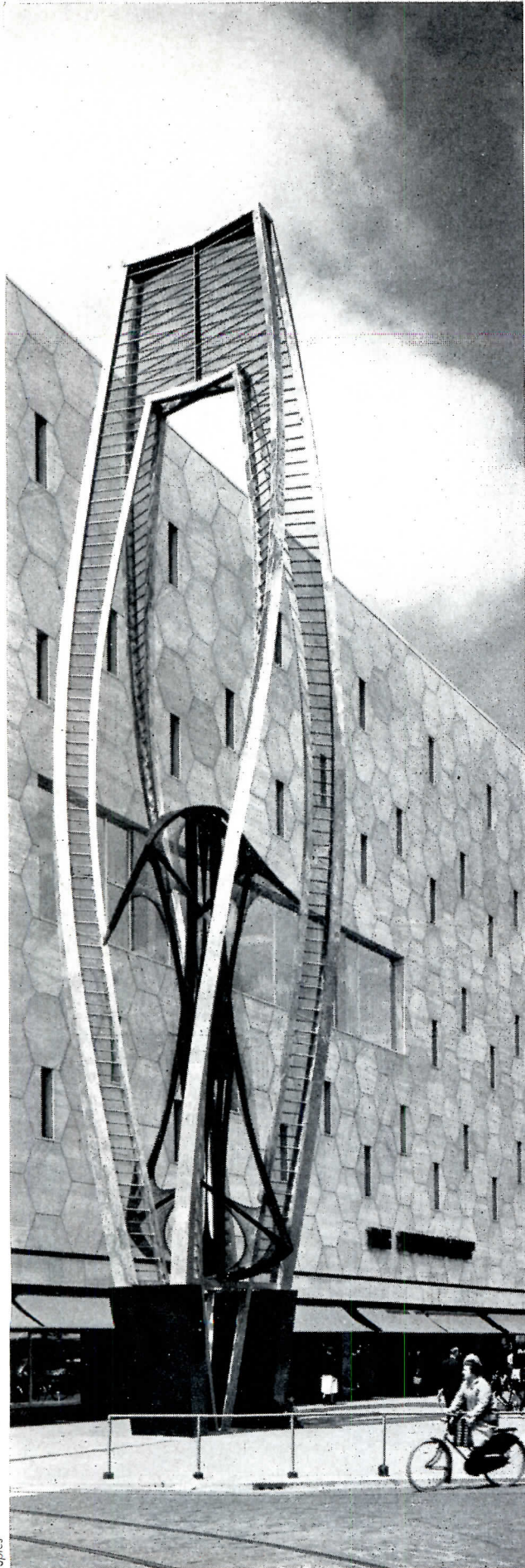

Spries

*INVITED.* Naum Gabo's sculpture, for De Bijenkorf in Amsterdam (Marcel Breuer, architect). Here, says the author, the artist must be free to express himself in his own medium.

ferred to in the first part of the statement is something commissioned from an outside artist, a man with an artistic integrity of his own, one assumes, and experienced in a medium capable of expressions outside architecture's range. If this man attempts to echo the architect's intentions (the reverse is never seriously considered) his sculpture will be manacled. Any separate meaning it could have will be distorted or diluted. No matter what euphemisms are used, it will be more ornament than art. It will be ornament which has the special advantage of leaving the architect's hands clean.

In the Seagram building, however, Mies himself is undertaking the sculpture which will sport in the two pools on the front apron. Why? Assuming that the father of simplicity in this country is not turning to ornamental trifles, he must have some compelling reason to sculpture: a message not capable of expression in his architecture. Then these pieces will not be part of the building, and coincidence of intention is irrelevant. In this case any sensitive sculptor could have been let loose on the pools. It is certainly a charming thought for an architect to do his own sculpture, but let us not confuse this hobby with his architecture.

Of course architects should see to it that more sculpture and painting are encouraged to enter buildings — and more music, and everyone should have more time to settle awhile in a favorite building and read Dylan Thomas.

Architecture thrives in the company of other arts, but the suggestion that she needs their support, is empty and incomplete without them, is a recurring indignity which no other art has to suffer.

Invite painting and sculpture and give them room, but let them speak their own minds; they are alive only when they are free. Architecture can never command their language, as they can never share the intimacy of her relations with humanity. Welcome them, but not in any guise of ornament.

Again, welcome sensitive selection in the insinuation of texture and color. I am not suggesting a blanket condemnation of everything not dictated wholly by the engineer or the banker. But at the point where insinuations begin to look important in themselves, when they lose servility to the form of the building and become in the least self-assertive, uppity — then immediately we can call them ornament and reach for a scalpel.

Ornament has no worthwhile meaning of its own, but is parasitic, riding on buildings, drawing its subsistence from the forms it rides, inevitably detracting from them and weakening the impact of architecture. It is, therefore, never an addition but always a subtraction. The forms and spaces should be a delight in themselves without anyone feeling any need for adornment; architecture can't escape this old axiom. It can only keep on delaying facing up to the implications.



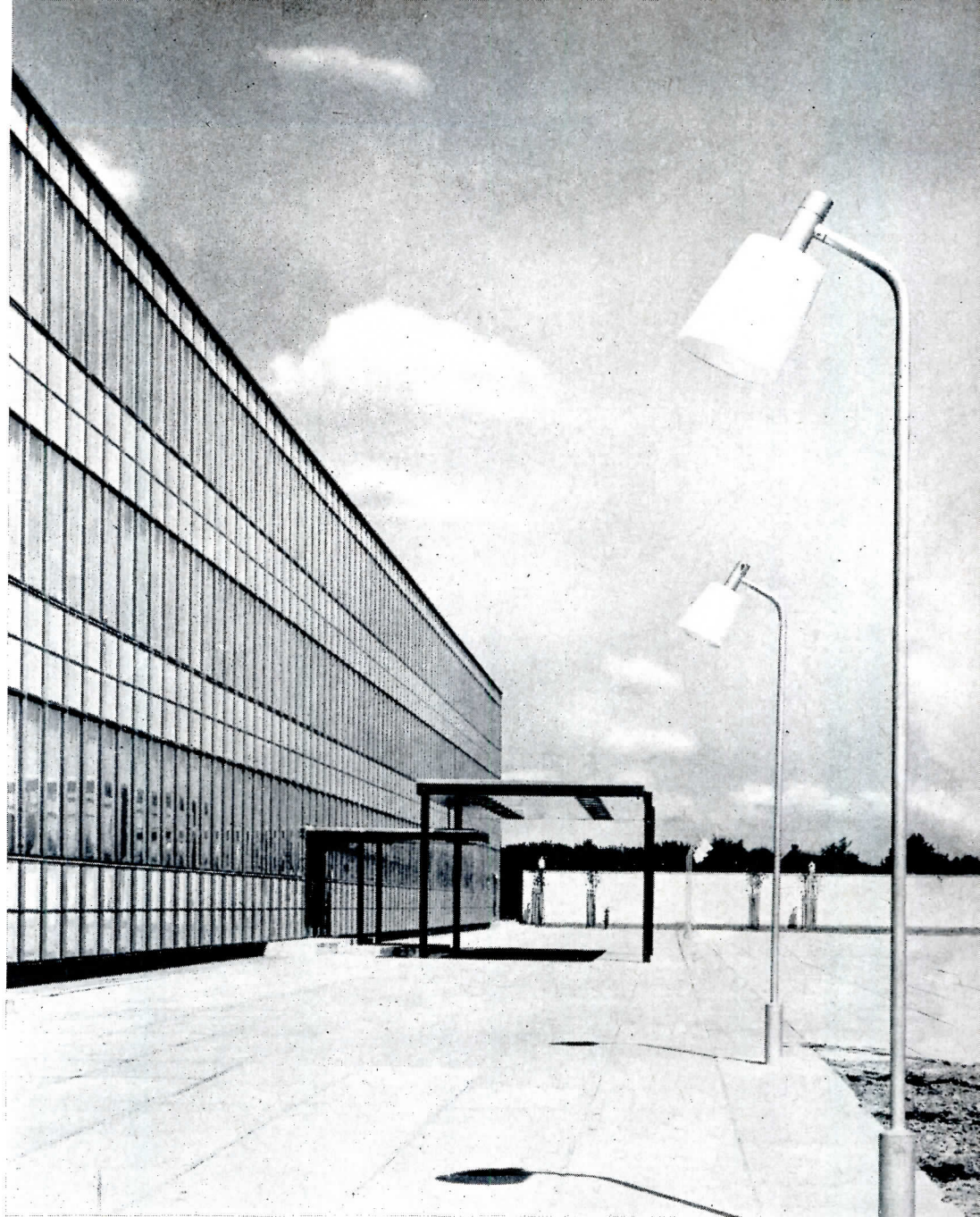

## DANISH CRAFTSMANSHIP BUILDS A TOWN HALL

By C. E. STOUSLAND

**S**IMPLICITY, flexibility, excellence of proportions, together with a craftsman's attention to details serve to elevate the Rödovre Town Hall well above the general run of glass boxes of the sealed skin idiom to which it bears such a striking outward resemblance. Leading Architect Arne Jacobsen's disciplined design of the three-storied façade is relieved by the simple free standing canopy which gives both dignity and emphasis to the principal entrance from the plaza fronting the building. A plastic quality is provided by the operating windows, which when open, create a pattern not unlike the Bertoa wall which is usually found in conjunction with the better boxes. The handling of the details is of that high level of craftsmanship which has long been associated with furniture, toys and silver of Danish origin.



LEGEND

- A. Entry
- B. Foyer
- C. Corridor
- D. Offices
- E. Council Chamber
- F. Meeting Room
- G. Cloak Room
- H. Men
- I. Women
- J. Engineer's Room
- K. Flower Box

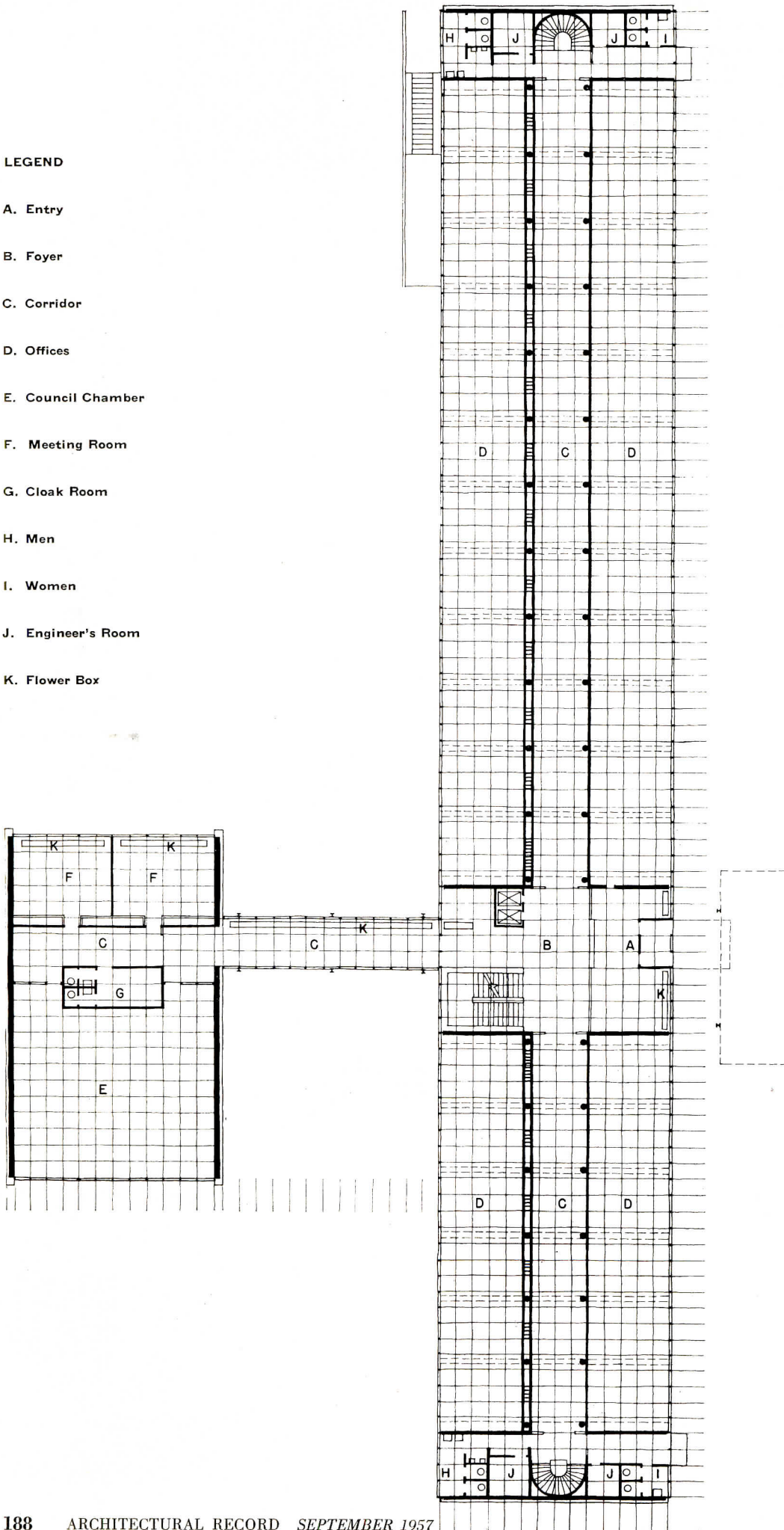



## RÖDOVRE TOWN HALL

A cantilever structural system is employed in the main office wing. As illustrated in the section at right, the cantilever is supported by two rows of columns at the corridor, freeing the exterior walls of structural supports and making possible maximum flexibility in office arrangements. All of the mechanical services are incorporated in a modular system which permits relocation of office partitions within an interval of one meter. Heating is from a central heating plant which serves a number of buildings in the area. The continuous acoustical clad ceilings were installed prior to the partitions. The partitions are demountable standardized elements of light metal construction sound insulated with lightweight concrete. Offices of officials are provided with double partitions to insure privacy. With a bi-nuclear scheme (see below and left) the idea of flexibility, so well developed in office arrangement, is extended to permit increased usage of the very fine conference-council room.

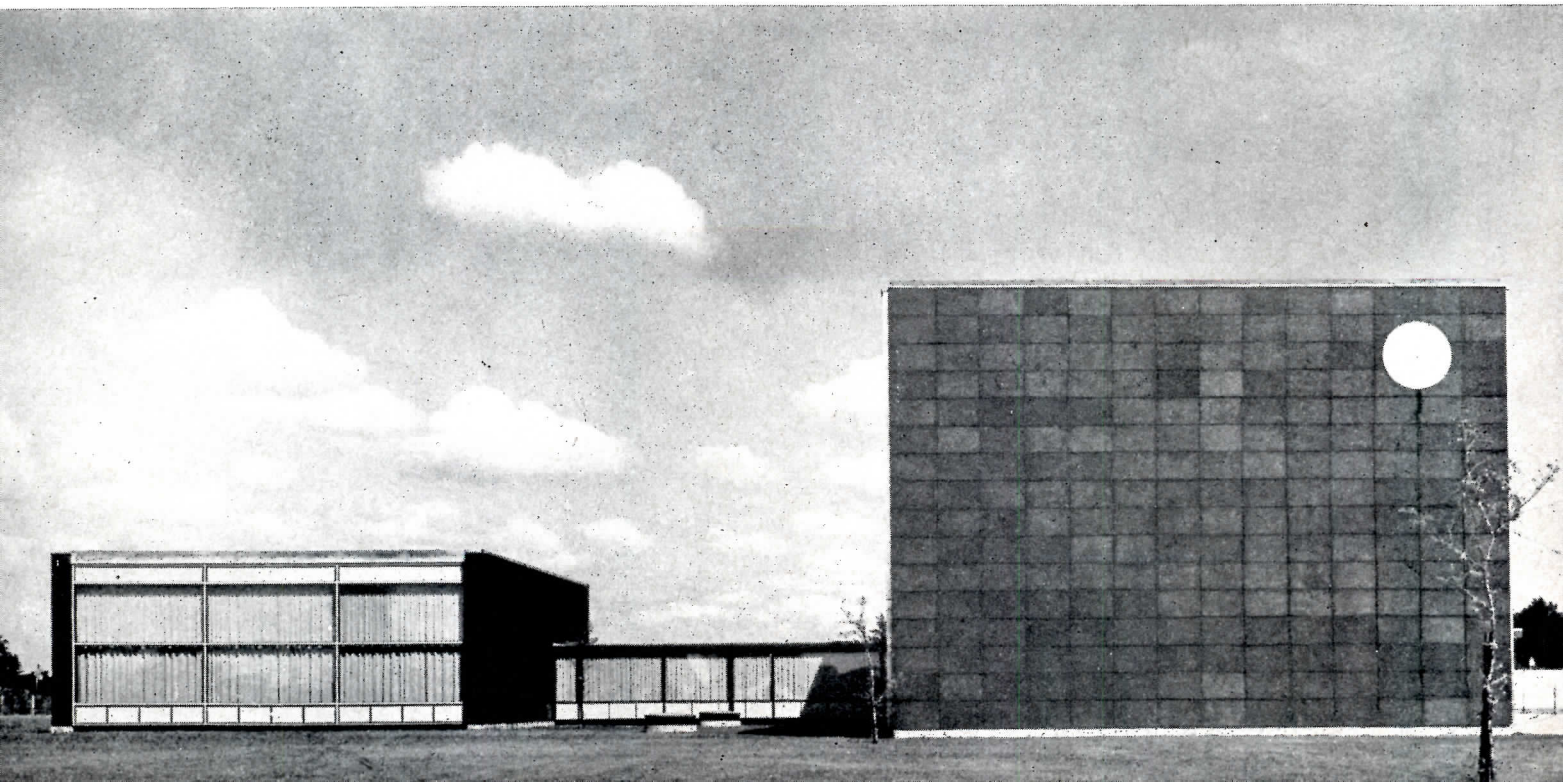
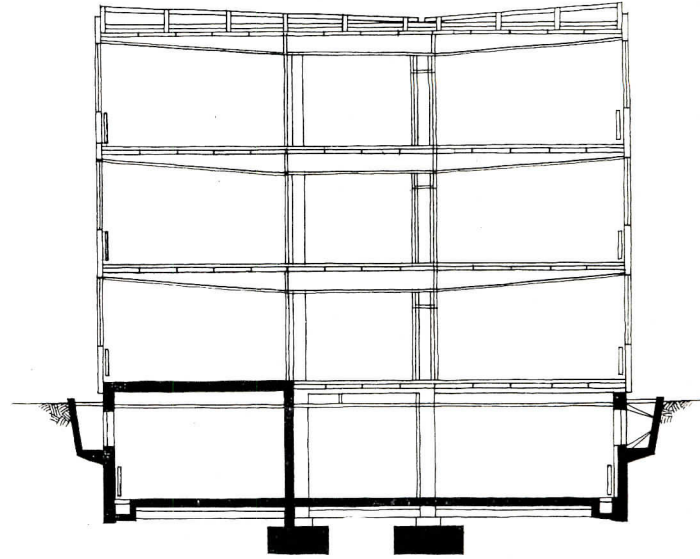



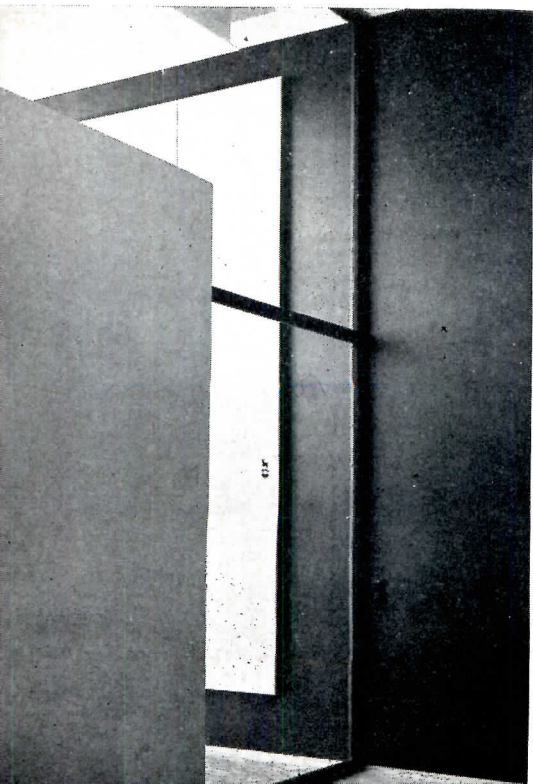



## RÖDOVRE TOWN HALL

The conference-council room illustrated at left is perhaps the finest of the interior spaces of the Town Hall. This by virtue of its scale, proportions, use of materials and well designed furnishings. In contrast to the overall feeling of simplicity a touch of delicacy is introduced by the ceiling lighting. The small regularly spaced fixtures suspended on metal rods provide an effective busyness which is a welcome intrusion in a space which might otherwise suffer from over simplification. At right an overall view of the building from a distance includes the stack of the central heating plant making the building even more reminiscent of our domestic variety of this type. Below a night view points up the proportions of the free standing canopy and the lower canopy connected to the building which projects under the larger, providing complete cover at the entrance and acting as a transitional element bringing the entrance down to a human scale. At lower left, a partition detail.

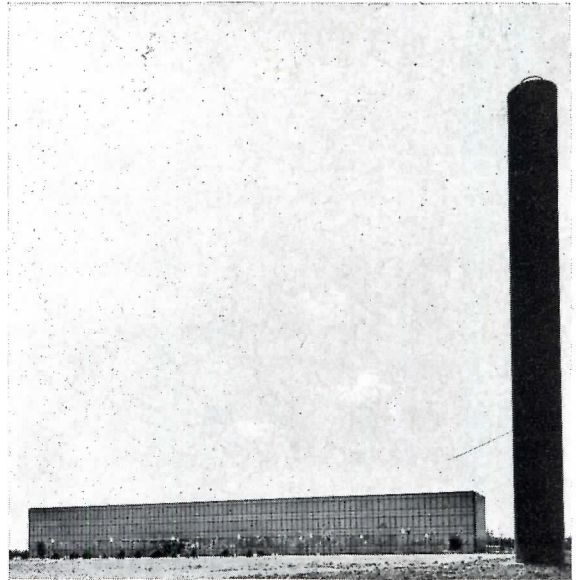





## RÖDOVRE TOWN HALL

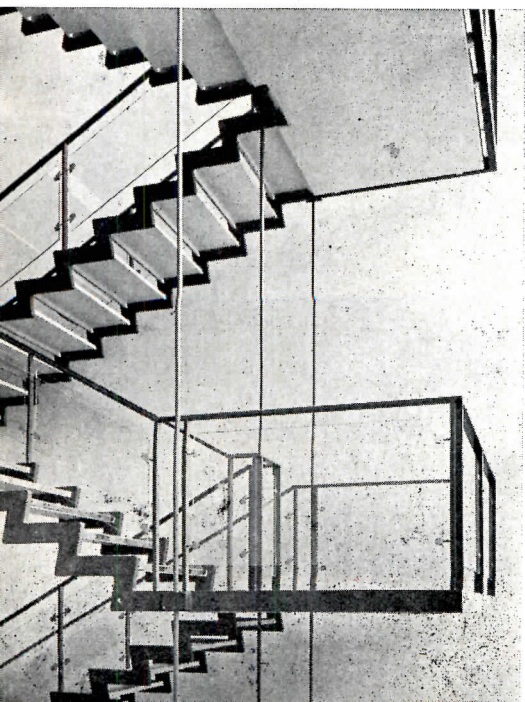
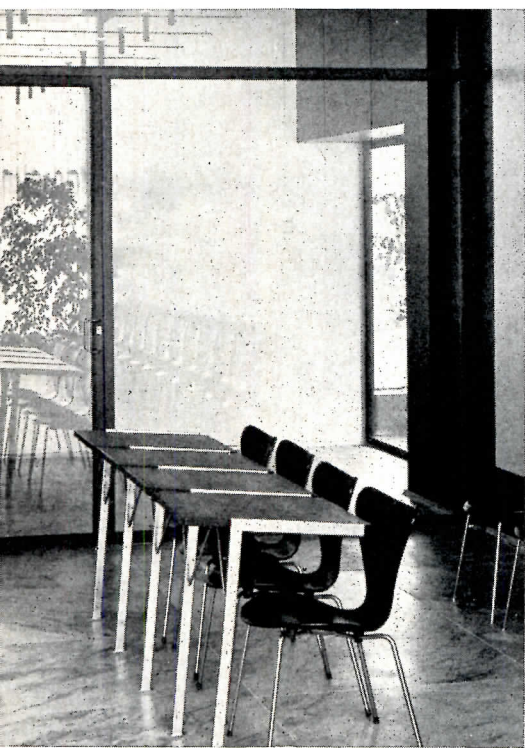

Top — Lightweight metal partition between corridor and office. Note continuous acoustical ceiling through glazed panel at the top of the partition. The treatment of the door handle and the escutcheon is typical of the attention given to details throughout the building. Center — From the council room a row of delightfully simple desks indicating some leg pulling on the part of the architect. The architectural amputation is performed with ease and grace worthy of the direction — *leggiero*. Beyond the reflective wall and to the right is the connecting link with the main lobby. Bottom — The feature of the main lobby is this rather unrelenting stair of steel and hardened glass, which though skillfully executed is hard, mechanistic and cold in contrast to the uniformly sensitive handling and character so evident in the remainder of the Town Hall. This seems to be a case of the spirit indeed quickeneth but the overall effect profiteth nothing.



# THE COURT HOUSE CONCEPT

By IAN L. MCHARG

THE FREE STANDING, single family house in suburb and countryside from such hands as Frank Lloyd Wright, Mies van der Rohe, Le Corbusier, Philip Johnson or Richard Neutra undoubtedly represents the greatest contribution of modern architecture to art and environment. Bear Run and the Farnsworth House, Villa Savoie and the Johnson New Canaan House offer a superlative environment for the exurbanite but what of the city dweller? Is not the urgent challenge to modern architecture to provide a new town house, as humane as those designed for the suburbs and country, as urbane as is consonant with the forms and values of the city?

A glance at the palette of urban housing types will only assure us of their conventionality — and their continuing inadequacy — the multi-story flat, no more than a bigger Roman insula with water, sewer, heating and elevator, the walk-up apartments but the insula without disguise, the terrace house shorn of nobility. This vocabulary sufficed until the city was befouled by industry, congested by traffic, despoiled by philistinism and abandoned to dereliction. These traditional housing types have been exploited since industry changed the nature of the city — and without success. No single present housing type is capable of arresting the flight to the suburbs, no single housing type offers the prospect of a new recentralization, no single present housing type offers an environment which can equal the salubrity of the suburb. Is there an urban house which, exploiting the advantages of city life, offers in addition a residential environment at least equalling the sum of advantages and disadvantages of the house in suburb or country? Can the essence of the free standing modern house be given an urban form?

Both questions can be answered in the affirmative. As supported by a number of projects during the past twenty years the court house, the introverted house facing upon one or more internal courts can provide the essence of the best free standing country houses; it can provide a residential environment as humane as it is urbane.

Moreover its range of application is surprisingly wide. Obviously it permits the creation of a new town house of great luxury and elegance but it also is adaptable to the creation of a popular town house at relatively high densities. The former house has the capacity to effect a selective recentralization — the return of the civilized to the cities, while the latter can provide for a recentralization of more significant proportions by providing a milieu for family life within the city.

The claims made for the court house concept are not puny, yet in the following pages can be seen their substantiation in a number of precursory projects. These are from distinguished architects in several countries. The unanimity of their concern for this concept and their projects within its formal expression deserve a generic title — the court house concept — and an

analysis of the essential quality, the range of application, the advantages and disadvantages of this concept of urban housing.

## *The Essential Quality of the Court House*

The court house is overwhelmingly distinguished by its introversion; the house turns its back to the street and faces upon a private, internal court or courts. The historical derivation from the peristyle and atrium of Rome and Greece, the traditional Moslem house, traditional Chinese and Japanese house is patently obvious and these plans indicate the geometric possibilities within the court house concept. The rectangular house and single walled court, the "L" house with one court, the square house with a single internal space, "H" and "T" plans each with two courts, the "Y" plan with three courts, the cruciform house having four courts and finally the possibilities of asymmetrical plans with numerous courts, these plans are united by the single fact that the quality of experience is oriented to the private delectation of the occupants.

The major problem of modern housing and its most conspicuous failure lies in the distribution and design of open space. Modern architecture has produced classic models for the two extreme conditions and no intermediate solutions. On the one hand, as can be seen in the Farnsworth House by Mies van der Rohe and the New Canaan House by Philip Johnson, the free standing house is placed in an area of beautiful natural landscape where its geometric purity contrasts vividly with the organic sculpture and texture of ground and trees. On the other hand Le Corbusier has provided the alternative model of the tall slab rising free from a lush romantic landscape. But for the intermediate problems of central redevelopment, urban renewal or a New Town there are no adequate solutions. Indeed in the case of the latter it is the inadequacy of the distribution and design of open space which is the key to the failure of the New Towns. There open space, offered as a boon, is in fact a liability; it contributes neither to amenity nor society while it disrupts any attempt to create "town" and finally — it contains no art. Open space is overprovided, usable open space is all but absent and the end product is a scene of insignificant houses lost in neutral open space.

Yet we have seen historically from Ancient Greece to the 18th century that good standards of open space are not antithetical to urban architecture. The 18th century squares represent a convincing defense of this position. Certainly there are intermediate solutions to be discovered appropriate to the problems and expression of modern architecture.

It is interesting to observe that most of the problems of open space are solved integrally within the plan of the court house. Open space in courts is provided internally and disassociated from the street scene. These



courts are private and this characteristic is the most valuable aspect of open space in housing. The courts can associate with internal functions to provide a living court, dining court, bedroom court, service court, etc. and provide a value to open space absent in all other plan types. By bringing the open space inside the house the scale of the street can be determined by traffic consideration and the height of the houses rather than being an uncontrollable sum of street and external open space. Finally the individual has a proclivity and a right to self expression in the design of open space. In current housing where this is freely expressed the result is often anarchy, vulgarity or both, where, as in the New Towns, it is suppressed, a neutral mediocrity is the product. In the court house the individual has freedom for personal expression which cannot obtrude on the public.

The court in the Orient has long been given a formal expression representing the essence of nature and is so realized with the philosophical assumption that man and nature are indivisible, and that contemplation, soliloquy and calm can best occur in nature, its essence if not its image, and the court then is made to represent the essence of nature. Again the Moslem court, based upon the Moslem concept of Paradise, has a religious basis for its formal expression in the Island of the Blessed and the four rivers of paradise. The West has no comparable basis for the formal expression of courts within houses and this must yet emerge as indeed must yet emerge the philosophy for the formal expression of a modern landscape architecture. One direction of this expression may be seen in the court of the Rockefeller House in New York, designed by Philip Johnson. In this as in other projects by Johnson one sees an esthetic consonant with the main stream of modern architecture and perhaps the precursor of the modern expression of the court in the modern court house. In the Western court as in the Oriental the value of this space is not alone in its functions but rather in its evocative use of natural and inert materials to induce soliloquy, calm, and an attachment to permanent values — in a word a humane environment.

The court house requires the expenditure of perimeter wall to create internal open spaces. The courts are the product. These are justified by the intimate relationship established between indoor and outdoor spaces. Indeed the courts become rooms outdoors. This being so the degree of privacy accorded to internal rooms is the minimum necessary for the courts.

In every historical epoch save our own the inevitable residence for the cultivated and influential, the civilized, polite and urbane as persons or families was the city. Today only a determined minority persists in the central city from choice and the family has been all but banished. The majority of the urban population lives in the city only because it lacks the economic mobility to escape and perforce lives in the slums, the meanness or the sanitary order of 19th and 20th century environment. The major population movement in this century has been the flight from the city, the greater the

economic mobility the further the residence from its center. The civilized, who traditionally made the city their own, the repository and the artifact of their culture, have today fled to the outermost suburbs. In Western Europe and the United States where they persist in cities they live in the reservoir of earlier historical town houses — in the Georgian and Regency squares and mews of Bloomsbury and Chelsea in London, the New Town of Edinburgh, the 17th century "Grachtenhuizen" of Amsterdam, the 15th century Palazzo Farnese, Quartiere del Rinascimento and Via Giulia in Rome, the Marais and Isle de St. Louis in Paris, Beacon Hill, Boston, Rittenhouse Square and Society Hill, Philadelphia and Greenwich Village in New York. Such town houses are no longer appropriate as prototypes, changed mores have caused their adaptation to contemporary residential needs while they are continually pre-empted for office space. Yet no modern town house has been produced to replace the traditional 17th and 18th century town house.

The metamorphosis necessary to create the mid-20th century city, stimulating yet humane, representing the zenith of the regional or national art, architecture, technology, social and cultural expression, this task poses many problems, but at their heart lies the necessity of returning to the city and accommodating there that segment of society most concerned with the problems of the city and best able to solve them. Not least then among the problems of the new city is the provision of a new town house. Such a house, while exploiting the existing advantages of city life must offer in addition a residential environment, at least equalling the sum of advantages and disadvantages of suburban environment. Without the introduction of such a new town house, that recentralization, which is the essence of the city's survival, cannot occur. Only by the provision of an urban residential environment at least equal in salubrity to that of the suburbs will the civilized, polite, urbane as persons and families return to the city to ensure its survival.

The court house represents such a town house, its merits are patent, they lie, not in modernity of the concept (unless modern is used as a synonym for good) but in an intrinsic excellence which its historical persistence substantiates. The court house does meet the criteria which have been advanced. It can provide a humane urban environment, an urbane architecture, a milieu for family life within the city; it does promise that recentralization which is the prerequisite to the survival of the city.

#### *Court House Plans*

During the past five years, recurring sporadically but with increasing frequency, the court house has appeared in the architectural press. It would appear that these projects constitute a precursory movement towards widening acceptance of the court house as the new town house.

As a modern housing solution the court house concept can be loosely identified with four principal sources



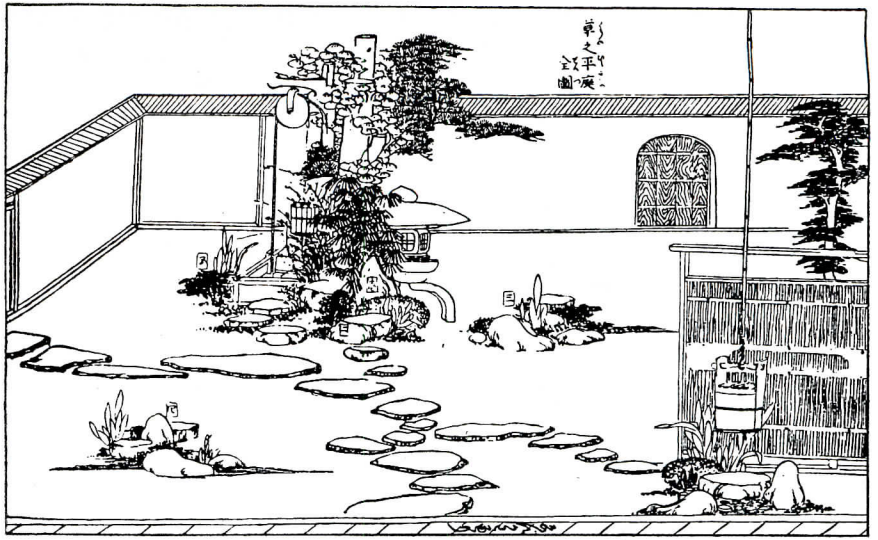

*Symbolical layout for Japanese garden*  
 (THE JAPANESE HOUSE AND GARDEN, by Tetsuro Yoshida)

George M. Cushing, Jr.

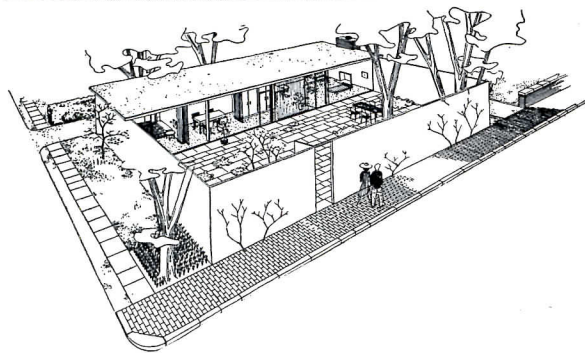
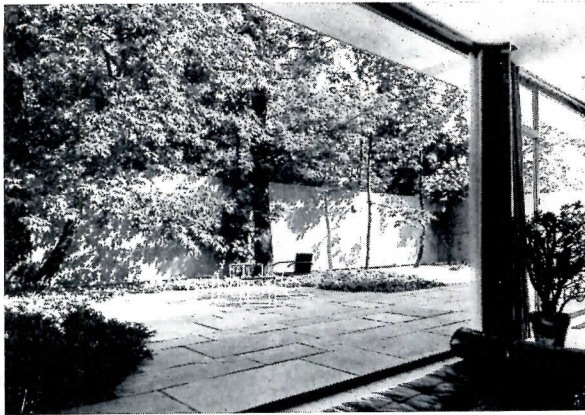

*Residence, Cambridge, Mass., 1942*  
 Philip C. Johnson, Architect

*Rockefeller Guest House, New York City, 1950*  
 Philip C. Johnson, Architect



Robert M. Damara

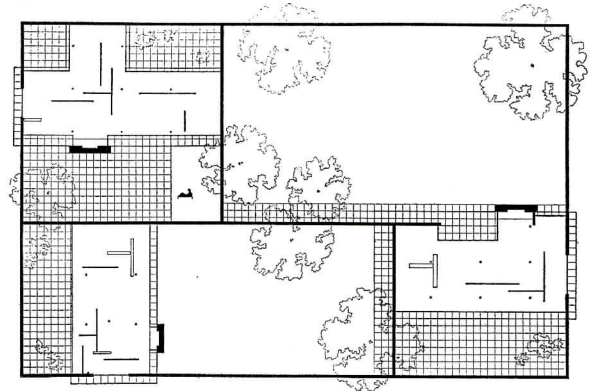

*Project for group of court-houses, 1938*  
 Mies Van Der Rohe, Architect  
 (MIES VAN DER ROHE, Museum of Modern Art)

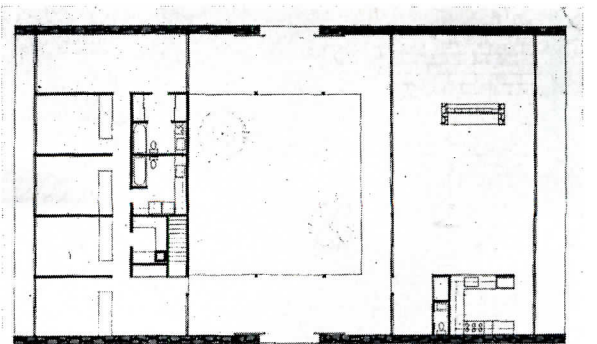

*Residence, New Canaan, Conn., 1955*  
 Eliot Noyes, Architect



only one of which is a direct extension of an historical form. The prime source stems from Mies van der Rohe and includes L. Hilberseimer and Philip Johnson; the second group, a logical extension of its Mediterranean origins is located in Italy and, starting from the studies of Pagano, Diotallevi and Marescotti, reached fruition in the housing at Tuscolano, Rome by Adalberto Libera. The third group, also deriving from the Mediterranean is identified with José Sert, his partner Wiener and their collaborators in many projects for Latin American cities. The fourth group is a direct extension of the Moslem tradition in North Africa directed today by French architects. Each of these studies originated before or during the war. In the postwar period, and particularly during the past two or three years the court house concept has gathered many new advocates in a wide range of countries — Mexico, Britain, the United States, Denmark, Sweden, Germany and Switzerland, and consequently is now advocated for other than Mediterranean and South American locations.

#### *Mies van der Rohe — Hilberseimer — Johnson*

Perhaps the first court house from the hands of a modern architect is a study by Mies van der Rohe developed in 1931. This is essentially a row house and is so described but each house is an "L" enclosing a private open court. This concept was elaborated and in 1938 Mies developed a more complex and princely group of three court houses associated in a block, each house distinct and each having a varying number of courts. This represents in the author's opinion the zenith of court house designs. Although at a density of approximately three houses to the acre, and consequently conspicuously open for urban conditions, there can be no doubt but that such development could fulfill the vital role of proffering an urban house equalling the best conditions of a suburban environment yet additionally offering the convenience of city life. A more recent project by Mies van der Rohe, the Gratiot in Detroit, falls between the studies of 1931 and 1938. In this housing complex court houses are interposed between garden apartments and multi-story flats. With one three bedroom court house, these dwellings are conceived as middle class, family houses. The court houses are designed in groups of six, arranged around two entrance courts which are in turn entered from a covered carport. If the 1938 project represents an urban alternative to the expressive suburban or rural house, the court houses of Gratiot offer a middle class equivalent. These projects by Mies van der Rohe are perhaps the best evidence for the court house as a middle and high cost urban house. Yet the quality of the court is still not indicated.

In 1942 Philip C. Johnson, biographer and collaborator of Mies, built a simple court house in Cambridge, Massachusetts. This house did not aspire to the luxury of the court house project by Mies but, with a small and elegant structure and one private court, there was developed a conjunction of structure, space and social

use impossible to achieve in such an area with a conventional plan. The court in this house remained simply as lawn, shaded by large trees, but in 1949, for the Rockefeller town house in New York, Johnson created a court with one pool, a tree, a fountain, terrace and three stepping stones. The impact of these few elements in this small space is overwhelming in contrast to the heat, fumes, noise, overpowering scale and tension of midtown Manhattan. This court, as a demonstration of the quality which can be achieved in a small urban space, is one of the most powerful exhibits as evidence of the validity of the court house concept and supplements the statements of Mies van der Rohe in which the court itself remains an enigma.

Prior to the projects of Philip Johnson, L. Hilberseimer, colleague of Mies van der Rohe at the Bauhaus and the Illinois Institute of Technology, had developed the court house concept as a form of popular housing. Utilizing the "L" shaped, single story house, he achieved densities of 120 persons or 20 houses per acre. This demonstration shows the court house as a popular housing solution applicable to central residential areas. In this Hilberseimer is supported by the historical precedents of Ancient Greece and Rome, ancient and modern North Africa and China.

#### *The Court House in Italy*

In 1940 the Italian architects Pagano, Diotallevi and Marescotti made an extensive study on the court house concept which was published in *Costruzioni Casabella* (April, 1940). The results of this examination are reflected in the writing of Eglo Benincasa today and more concretely in the housing project in the Tuscolano quarter of Rome, designed by Adalberto Libera and constructed, as low cost housing, by Ina Casa. This project appears to be the first modern example of the court house used as a popular urban house. It has an approximate net density of 30 houses per acre and, with seven beds per house, an envisaged net density of over 200 persons per acre. The repeated block plan, which consists of four "L" shaped houses, is a novel one. Three of the courts face inward while the remaining one opens to the pedestrian footpath. The courts are extremely small for the seven occupants of each house but this is in part compensated by common open space provided in the development.

The appropriateness of the court house concept to the Mediterranean would seem evident. Its appropriateness as a more general solution is indicated by Eglo Benincasa in *L'Architettura*: "Foreigners admire the 'picturesqueness' of the south, but underlying it there is a livability which the modern architect overlooks in popular housing. . . . The sheltered space constitutes a challenge to modern architecture. It is a free creation linking the house to nature."

#### *The Court House in South and Central America*

The third line of court house development is represented by José Sert, his partner Wiener and certain Mexican architects, notably Victor de la Lama. Sert, a Spaniard,



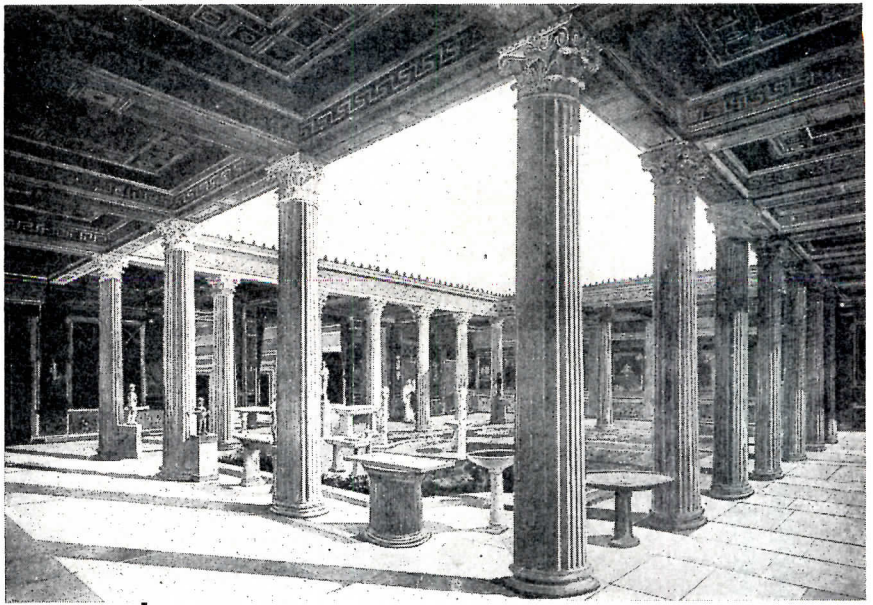

*The Vetti House, Pompeii*  
(The Bettman Archive)

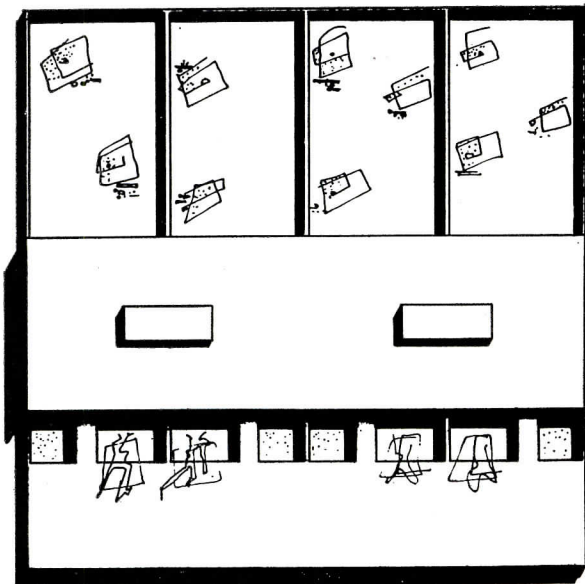

*Group of four medium-priced units in Mexico*  
Guillermo Rossell & Lorenzo Carrasco, Architects  
(MEXICO'S MODERN ARCHITECTURE, by I. E. Myers)

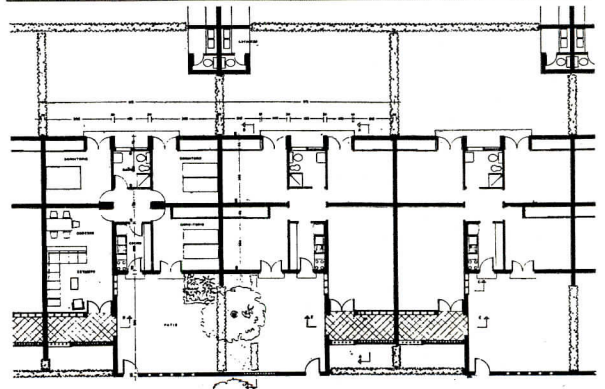
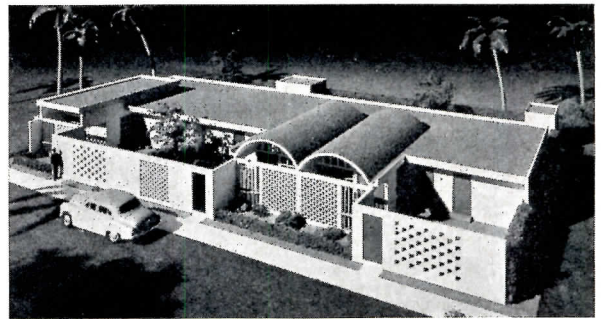

*Row houses under construction in Cuba*  
Paul Lester Wiener and Jose Luis Sert, Architects

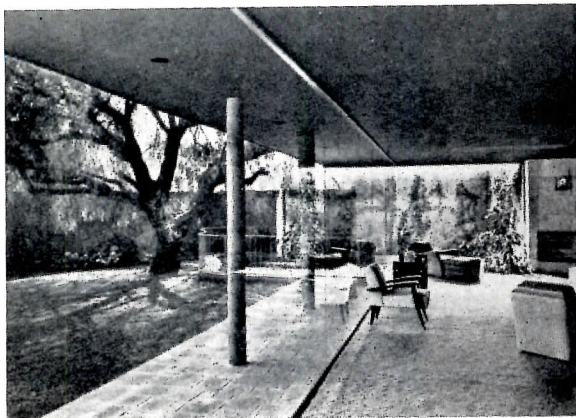

*Residence in Mexico*  
Victor de la Lama, Architect  
(MEXICO'S MODERN ARCHITECTURE, by I. E. Myers)



has adapted the Moslem heritage of the court house to his native land and made this the prototype popular house in his planning and housing studies for Central and South America. In the context of Latin America with a high sun angle, high temperatures and the Latin demand for privacy and protection the court house, its tradition, remains the most valid housing solution. In the hands of Sert and his collaborators the court house also represents an admirable means of ameliorating the micro-climate, a resource inherent in the plan but more vital in high temperature locales. Wiener and Sert are particularly distinguished by their long established attachment to this concept and by the skill with which they have utilized it as the basis for larger planning scales — nucleus, neighborhood and town. Indeed the distinctive contribution of these architects is that they have created a humane city in which the court house concept is the unifying element, appropriate to the climate, technology, art and mores of South America.

The typical court house plan utilized by Wiener and Sert is the "L" house with a service court cut from the exterior angle. This house is associated in groups of four to form a rectangle with the living courts located internally.

This attitude to orientation, acceptable in low latitudes, makes such a juxtaposition possible whereas it might well be questioned for other climates.

Whereas Wiener and Sert have utilized the court house as a low cost popular house, its exploitation in Mexico has been on a more lavish scale. The projects of Victor de la Lama particularly show the court house in terms analogous to the Mies van der Rohe 1938 court house. Each house contains a number of courts with swimming pools and lush sub-tropical vegetation. These demonstrate a standard of environment, albeit for a climate distinct from either Western Europe or the United States, which compares favorably with the free standing suburban or rural house.

#### *The Court House in North Africa*

In the western hemisphere the court house has persisted as a continuous concept only in the Moslem world. This housing type constitutes a vernacular form but it has also been utilized and exploited by modern architects as a contemporary solution. Numerous French architects, practicing in North Africa have used the court house as the prototype for Moslem housing projects. These developments are generally low cost with minimal standards; indeed it is apparent that while normally bedrooms, kitchen and bathroom are provided in the house, the living room, the only living space, is the open court. The court house concept in the hands of the architect J. Delaroziere has been used not only as a house plan but as the basis for a neighborhood plan with a hierarchy of open spaces extending from the private court to larger open spaces shared by nuclei to the final open space shared by the entire community (*L'Architecture D'Aujourd'hui* No. 60, 1955, p. 37).

#### *Recent Court Houses*

Developing from the court houses of these four groups are a large number of recent projects from a wide range of countries. From a Mediterranean and Hispano-American base the concept has entered throughout Europe and penetrated North America. Almost all the major European countries are represented in court house projects and this housing type has been advanced for countries as distant from the Mediterranean as Denmark. These projects include "L" shaped court houses by Custer, Escher, Gisel and Weilenmann proposed as an extension to the Neubuhl in Zürich (*Bauen and Wohnen* 10, pp. 22 and 23), the "atrium house" by George Schwindowski of Berlin (*Bauen and Wohnen* Jan., 1956, pp. 35 and 36), studies by Eske Kristensen (*Arkitecler*), and John Utzon (*Architects Year Book #6*) in Scandinavia, projects by Netherland students (*Forum*, Netherlands), the Smithson house for the Ideal Homes Exhibition 1956 (*Architectural Design*, March 1956, pp. 101 and 102) with which a written explanation reads "all rainwater is collected and runs through a gargoyle to a container in the internal garden!" These projects, while amenable for use in urban situations are not so proposed. In contrast, a project by the architects Chamberlin, Powell and Bon (*Architectural Design*, Oct., 1956, p. 327), utilizing the court house concept aims at central urban locations and high densities. This solution, with an average height of one and a half stories provides a net density of 160 persons or about 30 houses per acre. The aim to maximize the applicability of the court house by maximizing density is laudable and the solution is extraordinarily ingenious. Particularly noteworthy is the success achieved in either eliminating or minimizing the degree of overlooking into private courts while employing a two story bedroom unit. Yet there is some reason to believe that the density may be excessively high for this house type and that with the low sun angle of Britain the courts might well become insalubrious holes. Further, where the courts are so small it would appear vital to provide a secondary area of open space which this proposal fails to grant. With the private court provided for the family, yet another area should exist as focus and venue for social intercourse in the community. Yet this is perhaps the best example to date of the court house as a popular urban house. Densities of 160 persons per acre or even 100 persons to the acre, supplemented by tall buildings can, as the architects indicate, provide densities perfectly compatible with urban land values and building values.

Beyond the Mediterranean and Latin America, it is in the United States that the court house concept has taken the strongest hold. This is assuredly not unconnected with the presence of Mies van der Rohe, Philip Johnson and L. Hilberseimer and their attachment to this concept. It may well also be influenced by the existence of a Hispano-American tradition in California and the southwestern United States. The preoccupation with the court house is evident but remains to date in the project phase. In addition to those architects



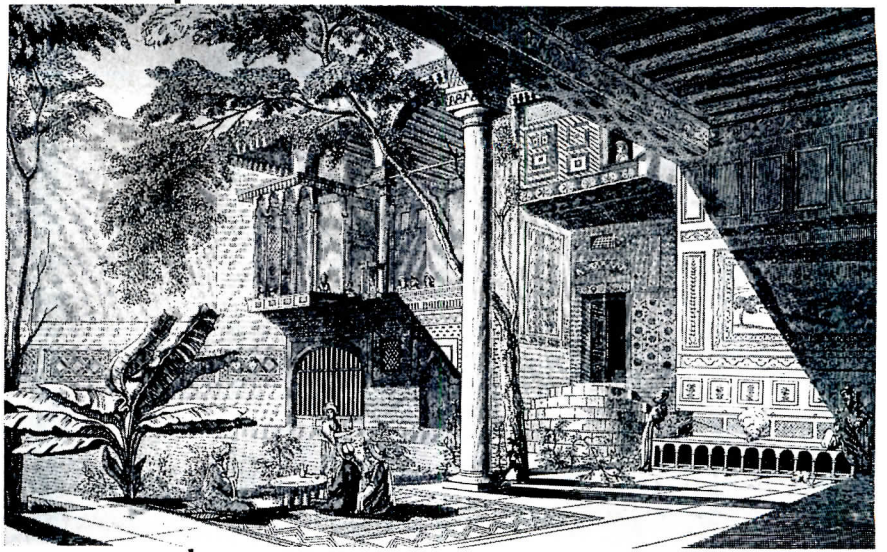

*Old residence, Cairo*  
(The Bettman Archive)

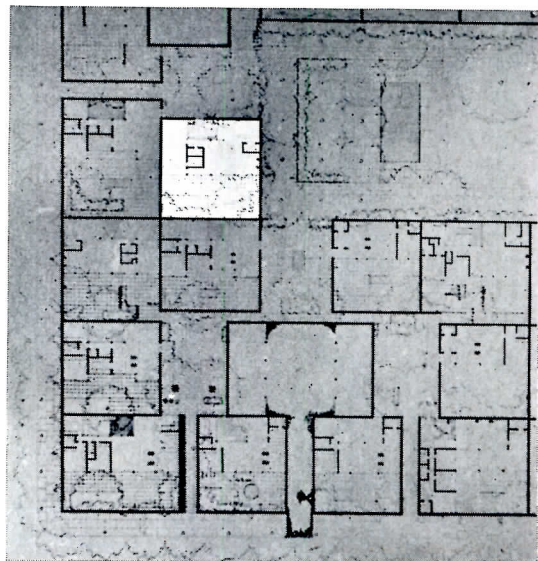
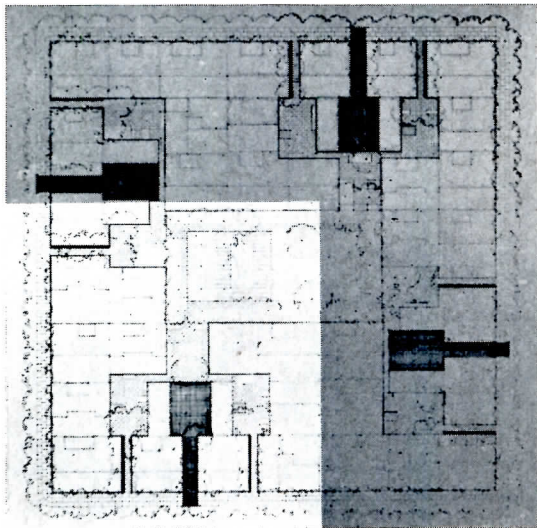

*Court house study made at University of Pennsylvania  
for central Philadelphia block:  
site plan, left above; quadrant plan, above;  
typical unit plan, left*

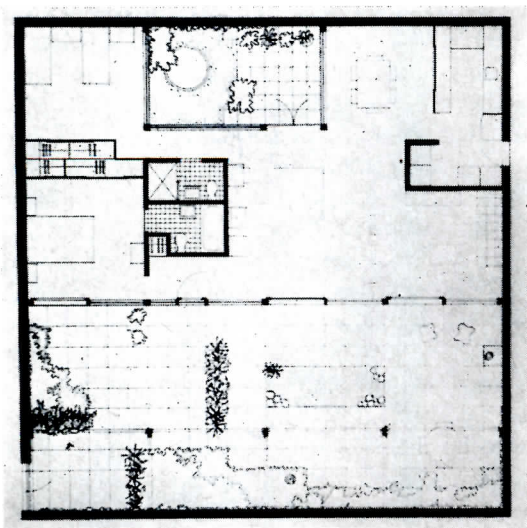



mentioned above, Serge Chermayeff, Oskar Stonorov, Ralph Rapson, Donald Olsen and Morse Payne have all produced court houses or court house complexes. Donald Olsen has designed a swastika house with four courts (*Arts and Architecture*, April, 1948); that by Ralph Rapson has a single internal court (*Interiors*, September, 1948, p. 119).

The project by Morse Payne (*Interiors*, January, 1956, pp. 69-71) exploits the court house concept in a distinct way. The lot is a long rectangle which is divided into three or four courts — by the interposition of building volumes, usually two or three in number — the living-dining-kitchen volume, the bedroom volume or the bedroom function divided into the master bedroom volume and the children-guest bedroom volume. By raising certain of these volumes the entire space can be continuous or divided into distinct courts associated with specific functions. This plan might well be described as the in-line court house and represents an admirable addition to the vocabulary. The density is approximately 15 houses or 90 habitable rooms per acre.

Serge Chermayeff, Oskar Stonorov and Mies van der Rohe have during the past year developed not only court houses but associated these in small groups. In the study which Chermayeff has conducted with students of the Harvard Graduate School of Design, the house, with a "U" plan has three courts — two external and one internal. This prototype house is associated in groups of six, but could be exploited as a row house. Before Mies van der Rohe designed his Gratiot project Stonorov prepared a scheme for this development in which he utilized court houses. This project aims for a higher net density for the court houses than does the subsequent scheme by Mies van der Rohe. To achieve this, two story quatrefoil court houses were developed. Given the absolute necessity of building two story structures this design is admirable, but it must be observed that all courts suffer from overlooking and the value of the court is depreciated.

The court house as a house plan has been thoroughly demonstrated and in the projects by Mies van der Rohe, Stonorov and Chermayeff can be seen small nuclei made with four to six court houses. In Gratiot by Mies the group of houses depend upon a single car court and each trio of houses share a common entrance court. However, save in the single project of Adalberto Libera in Rome there is no evidence of the court house as an element in a community. Towards the end of exploiting the court house as an element in the small urban community, graduate students of the University of Pennsylvania under the direction of the author, made studies for a central Philadelphia city block site.

In this study the intention was not only to exploit the court house but to create a community which would be as salubrious at the community level as would be the court house at the dwelling level. The program required houses from 1500 to 3000 sq ft with provision for one car per house. To create the court house community it was required, as in the subsequent

Gratiot projects, that groups of six to ten court houses depend upon one common court acting as forecourt and that beyond that a central open space with small playground, swimming pool be provided as the venue for social intercourse in the block. The net density averaged twenty houses per acre, the gross density within the block was half that figure.

It is submitted that this final stage of utilizing the court houses around a sequence of open space as venue for social life constitutes an advance in the exploitation of the court house, that it does present an environment as urbane as it is humane, consonant with the forms and values of the city. The author, in collaboration with Philip Johnson, is in the process of designing such a project in central Philadelphia.

### Conclusion

The housing solutions which have been advanced or utilized in this century fall into three main categories; the two extremes of the multi-story flat and the free standing, single family house and, between these, the terrace-row semi-detached house. The multi-story flat has particularly been espoused by the leaders of modern architecture. From Le Voisin, La Ville Radieuse, The Siemensstadt, "De Plaslaon" in Rotterdam and their derivatives to the Unités d' Habitation, modern architecture had advanced the multi-story apartment as the prime urban house type. Yet it hardly justifies this devotion and dependence on the grounds of its modernity. Some reaction to this preoccupation and devotion to the flat has appeared within C.I.A.M., founder and prime protagonist of modern vertical living. At C.I.A.M. 10 the English members W. and G. Howell, J. A. Patridge states that "Even if and when we have built up a successful tradition and practice of multi-level living, which we are very far from having done — we feel that — there will always be a demand for a considerable proportion of (town) houses. And if the program demands it we must find ways of using them as elements in the city" (*Architectural Design*).

Although having a recurring role for two thousand years, the multi-story apartment has not built a successful tradition; it has found only limited acceptance and far from offering the key to a new and selective recentralization, is unable to arrest decentralization.

The realization must be all the more disheartening to the protagonists of vertical living in view of the fact that the concept has been advanced during a severe housing shortage when choice was severely restricted. The Unités, Barbican, High Paddington, the Smithson concept, Gratiot all point towards improvement in multi-story development and the tall apartment will continue to play an important role in central city housing. However, it is not a sovereign cure. The vocabulary urgently needs to be expanded; the court house constitutes an invaluable addition to the vocabulary of central housing. The court house can return the civilized, the urbane and polite to the cities, offer the milieu for family life within the city and provide an environment as urbane as it is delightful.



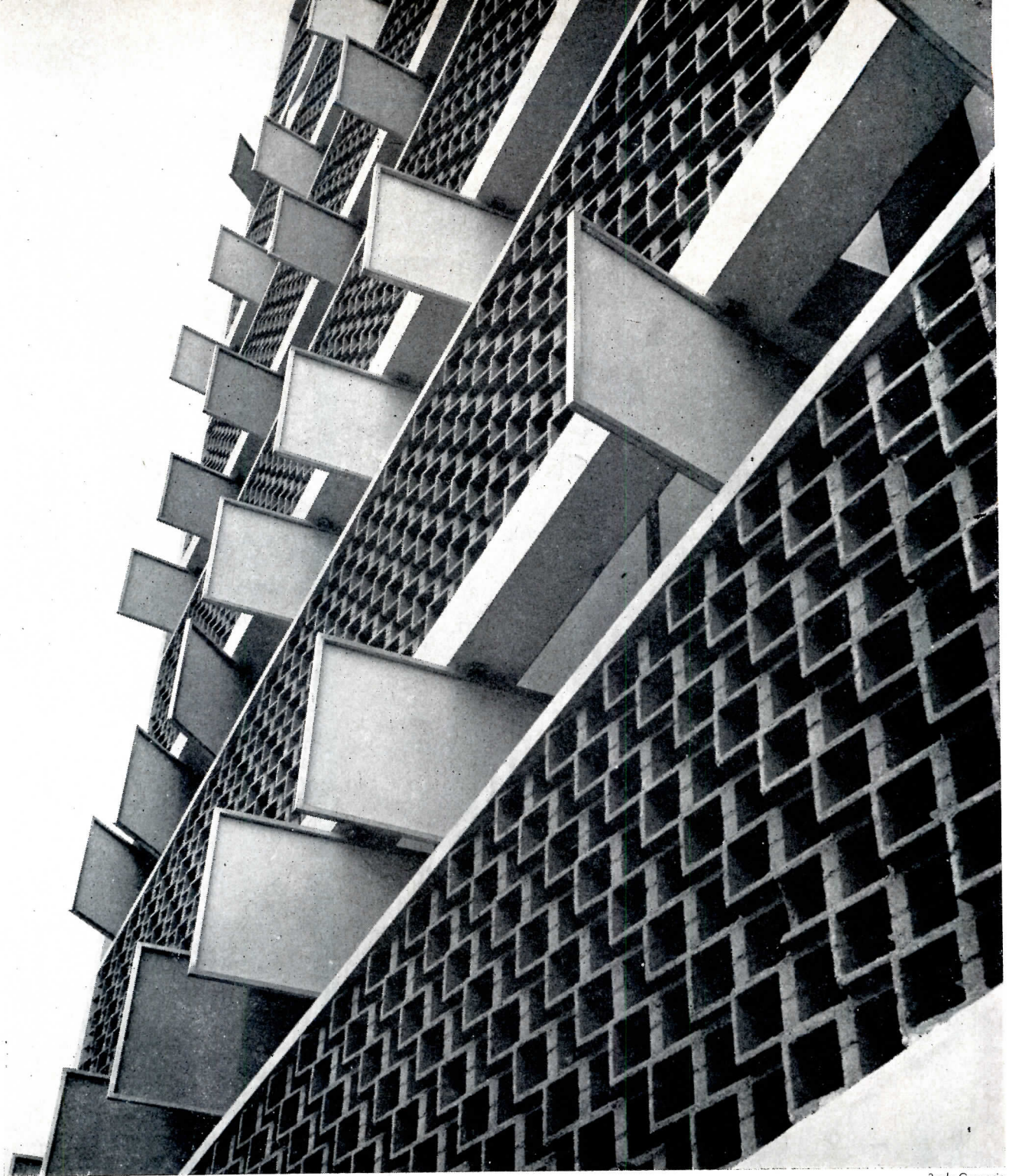

*Sun Screens on office Building, Caracas. Carlos Guinand and Moises Benacerraf, Architects*

Paolo Gasparini

## **HIGHLIGHTS OF VENEZUELA'S BURGEONING NEW ARCHITECTURE**

The following pages sample a sparkling exhibit of Venezuela's current and enormous building boom on view August 21 to September 15 at New York's World Affairs Center Exhibit Hall. It will then show for two months at the Pan American Union, Washington, D. C., and tour U. S. Architectural Schools. Sponsors are the Venezuelan Society of Architects and the Creole Petroleum Corp. It was prepared by Cipriano Dominguez, Luis Ramirez, Paolo Gasparini and Mateo Manaure.



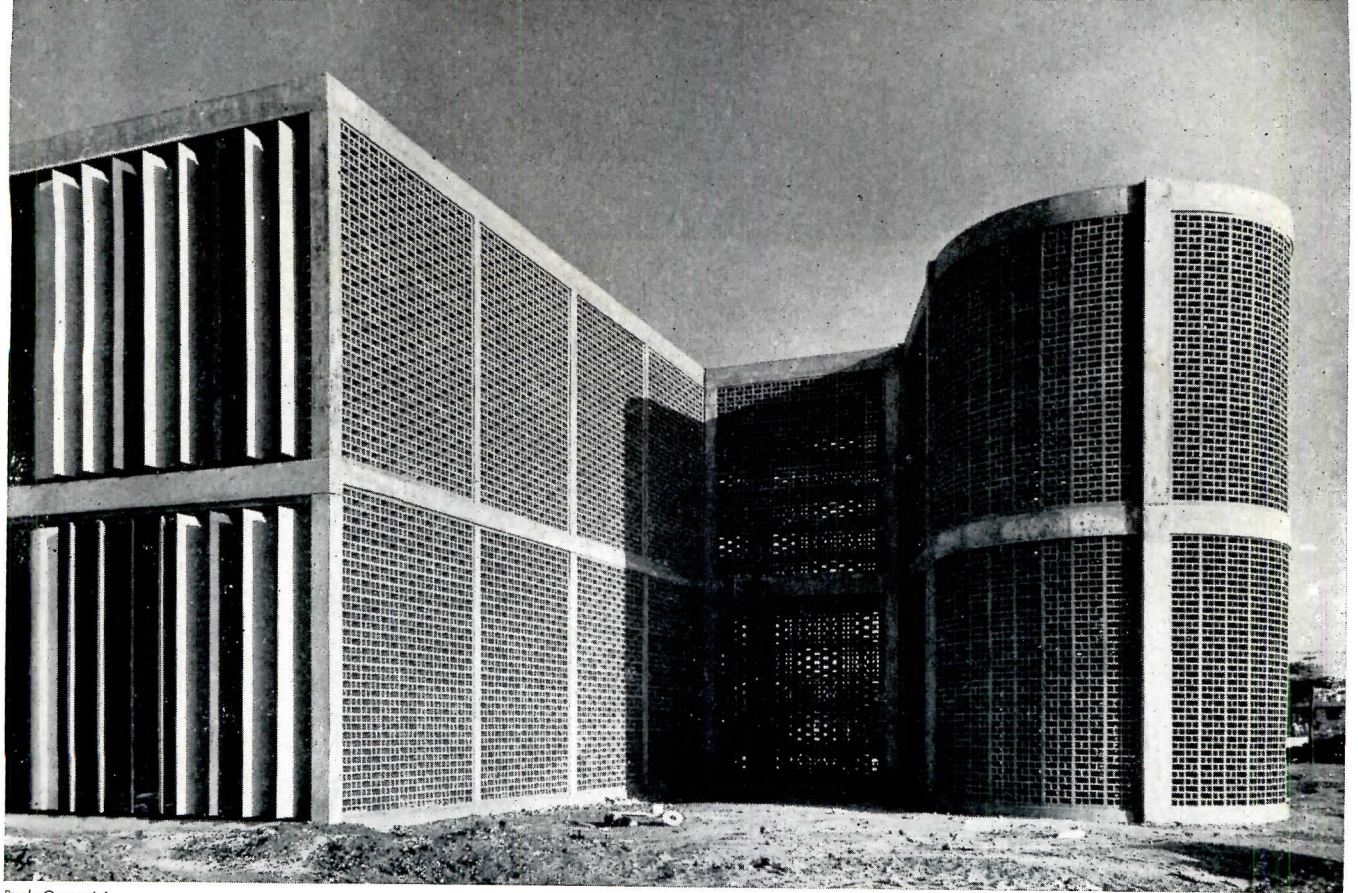

Paolo Gasparini

*School of Petroleum Engineering, Univ. of Zulia, Maracaibo. C. R. Villanueva, Architect*

**VENEZUELA'S NEW ARCHITECTURE**



*School of Architecture, University City, Caracas, 1957. Carlos Raul Villanueva, Architect*

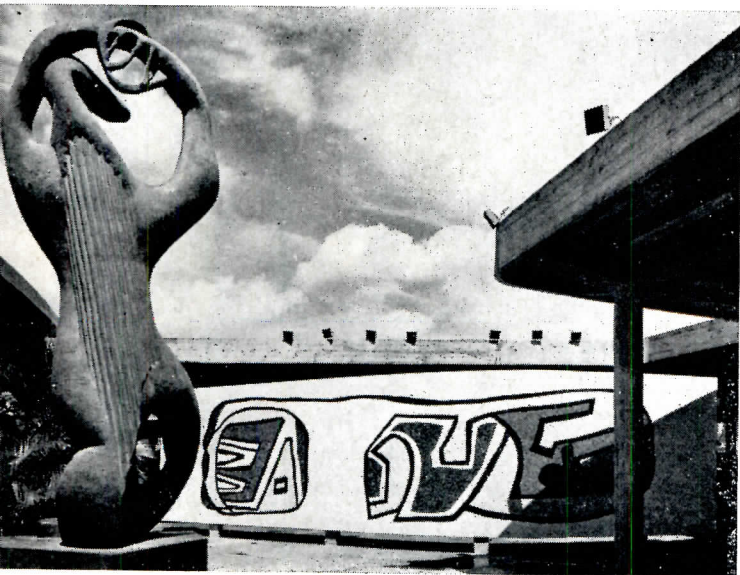

*University City, Caracas, begun in 1942. Sculpture by Henri Laurens, mural by Fernand Léger. Carlos Raul Villanueva, Architect*



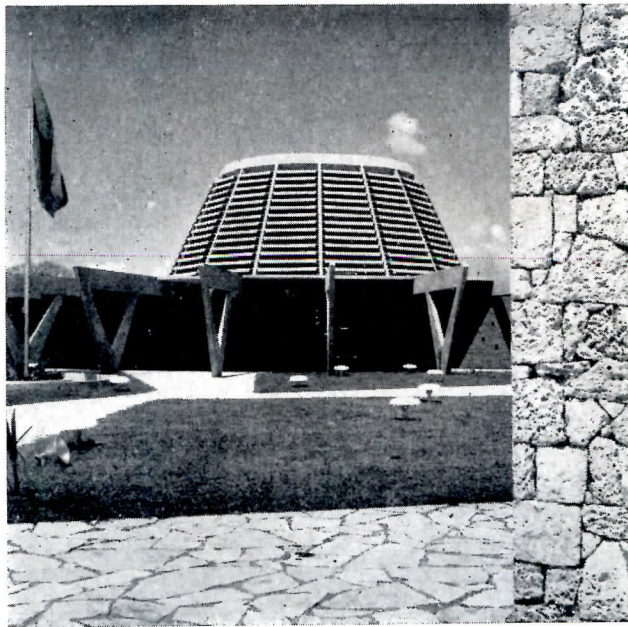

*Pavilion designed for international exposition,  
Santo Domingo, Dominican Republic, 1955.  
Alejandro Pietri Pietri, Architect*

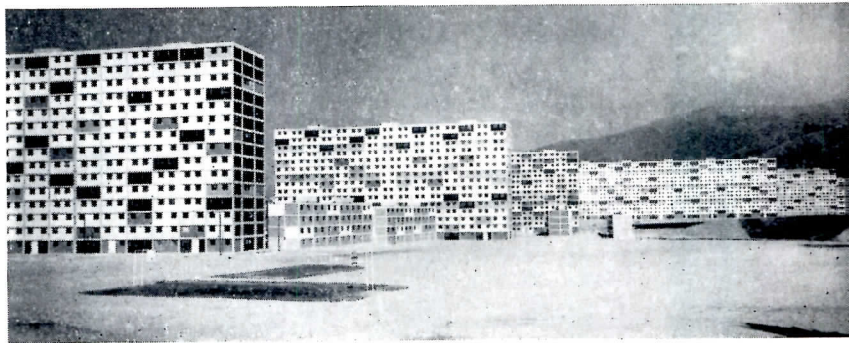

*"2 de Diciembre" Housing Development of the  
Banco Obrero, Caracas, 1956-57. Carlos Raul  
Villanueva, Jose Manuel Mijares, Jose Hoff-  
man, and Carlos A. Brando, Architects*

*Cerro Grande Housing Unit, Caracas, 1954.  
Guido Bermúdez, Architect*

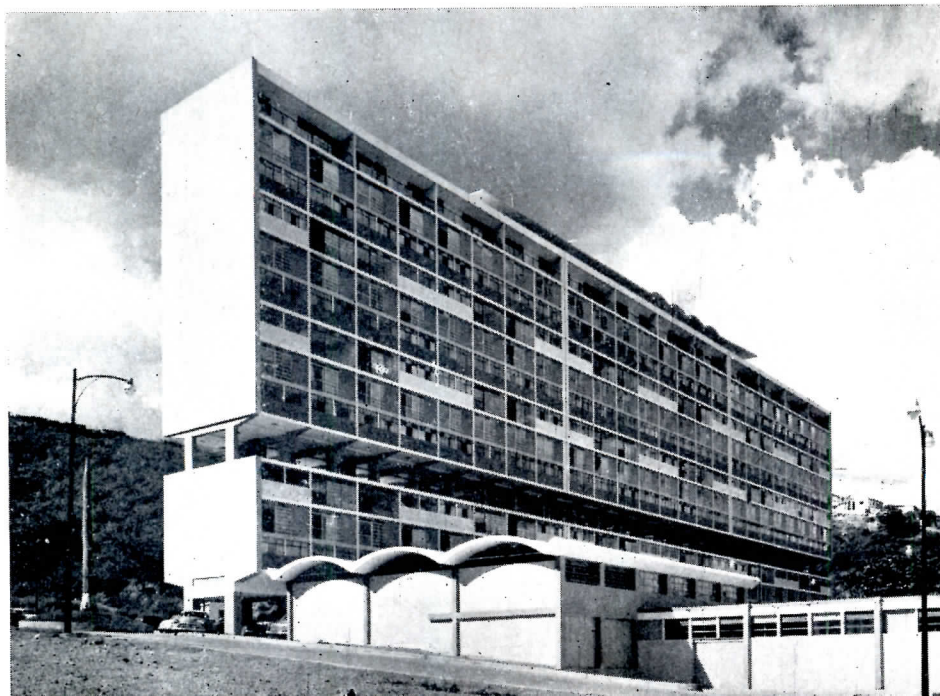



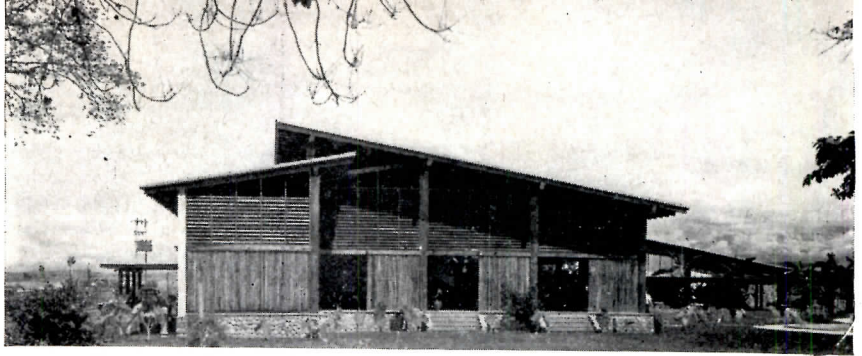

*Hotel Alto Llano, Barinas, 1956. Oscar Carpio and Guillermo A. Suarez, in collaboration with Ramon Burgos, Architects*

**VENEZUELA'S NEW ARCHITECTURE**

*Mariperez Cable Terminal, Caracas, 1955-56. Alejandro Pietri Pietri, Architect*



*Paolo Gasparini*

*Hotel Prado del Rio, Merida, 1957. Tomas Jose Sanabria and Julio C. Volante, Architects*





# Shopping

## CAN BE A PLEASURE

SUBURBAN SHOPPING *can be* a pleasant experience, but seldom is. Great numbers of shopping centers, large and small, are being built across the country, but the unhappy truth is that the overwhelming majority of them are neither good to look at nor a real pleasure to use. The American genius for turning a profit seems, in suburbia, to be wedded to a distressing penchant for bringing merchandising blight to the land as part of the process. In terms of logic, convenience, or visual delight, the typical shopping center offers little. Occasional exceptions, such as the centers presented here, demonstrate by contrast the validity of this judgment. Suburban shopping *can be* a pleasure.

There have been good results from the large amount of study devoted to the location, planning and servicing of retail stores; and to their grouping into a smoothly functioning center that performs as a profitable mechanism for sales. But there has been far less accomplishment in the design of the spaces between and around these stores; their parking areas; the relationship of such centers to the highway and community; in brief — the *shopping environment*. This is the aspect of shopping center design that can make the difference — and the creation of a delightful shopping environment for the stores is specifically an architectural obligation. Further, only when many more owners appreciate the role of such an environment and the unique role of the architect in achieving it can large numbers of shopping areas benefit in both financial and human terms.

An attractive center that people enjoy visiting will make a larger profit in today's economy and will survive when others fail in a still more competitive economic climate. Smart business men value friendly human relationships and community respect; Marshall Field & Co. is pleased indeed that many people come to Old Orchard (pp 220-228) on Sundays — when all the stores are closed — simply because it's a pleasant place to be. This is good business.

When one visits any shopping center, he engages in certain distinct phases of an essentially circulatory activity. First, he must gain access, drive in and park. Second, he must move from his car to the store group and then to his first shopping stop. Next, he must move from that store to others. Finally, he must return to his car. This process occurs in three physical areas: the access and parking area; the parking-to-store belt; and the malls, walks, courts, etc. between and connecting the stores. It is with the sizes, shapes, surfaces, and dispositions of these three that the architect must be concerned if he is to create the captivating atmosphere that will draw people back to the center again.

In this study we have narrowed our attention to this aspect of the total problem of shopping center design. We present three centers; one large, one medium in size, one small. Each of these makes a significant contribution in the direction of a delightful climate for suburban shopping.

— JAMES S. HORNBECK



# TRIFIELDS





## IT'S FUN TO VISIT AMERICA'S LARGEST SHOPPING CENTER

*There is interesting variety within a skillfully organized, dominant architectural pattern at Roosevelt Field. There is an assuring, human scale everywhere — not easy in the world's largest center; there is visual intrigue and delight — changing, colorful, but always under control; and there is an ordered, easy-to-learn traffic flow for pedestrian and driver. In short — it's fun to shop here.*

Architect I. M. Pei says, "The site plan is essentially a free-flowing ring road surrounding a central building group. The stores form a compact cluster, minimizing walking distances and heightening cumulative drawing power. The relatively narrow malls encourage cross shopping, double the presentation of merchandise, and heighten the impression of activity. The shopper's route leads him through streets of different widths and varying architectural treatments, affording a variety of experiences. Trees, flowers, music, fountains, gay awnings, and bold use of graphic art combine to make the retail atmosphere. Variety of store front design along malls was encouraged.

"Store fronts facing parking areas are designed by the center architect to give the impression of a planned center, yet provide tenant identification. A modular system of dark-brown steel frames, rough-faced off-white brick and glass was used. Within this system, each store was given individual treatment."

Throughout, the structural module is 26 by 32 ft, with the basic 26-ft store front dimension subdivided into 4 parts. Basic heights: inner stores 12 ft; outer stores 16 ft; doors 7 ft. Sign sizes, colors and materials are rigidly controlled.

1—Two variety stores and lower priced-apparel stores, 2—Specialty shops, 3—Quality stores, mainly apparel, 4—Hard goods, housewares, 5—Macy's, 6—Supermarkets 7—Outdoor skating rink.

### ROOSEVELT FIELD SHOPPING CENTER Nassau County, Long Island A Webb & Knapp Project

*Architects: I. M. Pei & Associates. Project Staff: O. Aftreth, A. P. Moore, J. LoPinto, A. Candido. Graphics Head: Don Page. Associate Architect: R. C. Brugnoli. General Contractor: George A. Fuller Co.*

*Consultants: Structural, Severud-Elstad-Krueger; Mechanical, Syska & Hennessy; Special Lighting, H. Abe Feder; Landscape, Robert Zion; Traffic Engineers: Wilbur Smith*

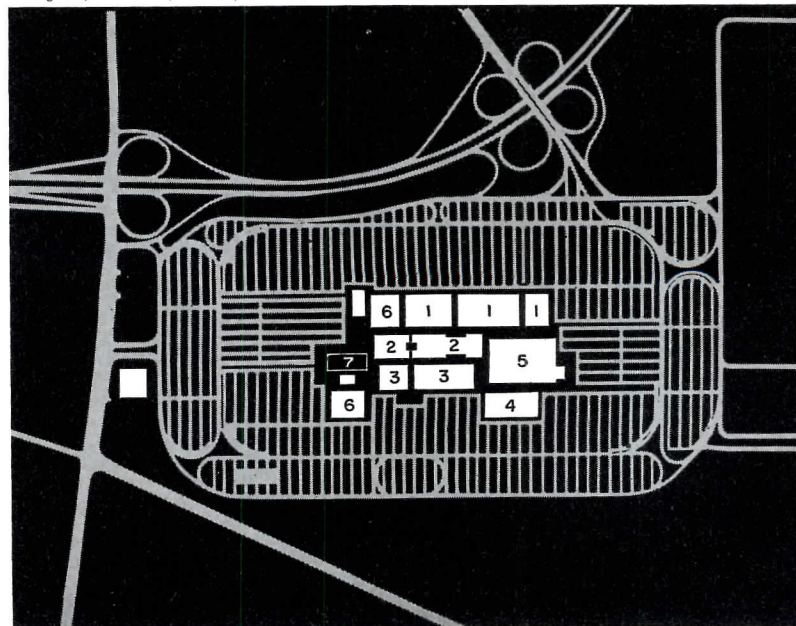

Photo, left page, by © Ezra Stoller







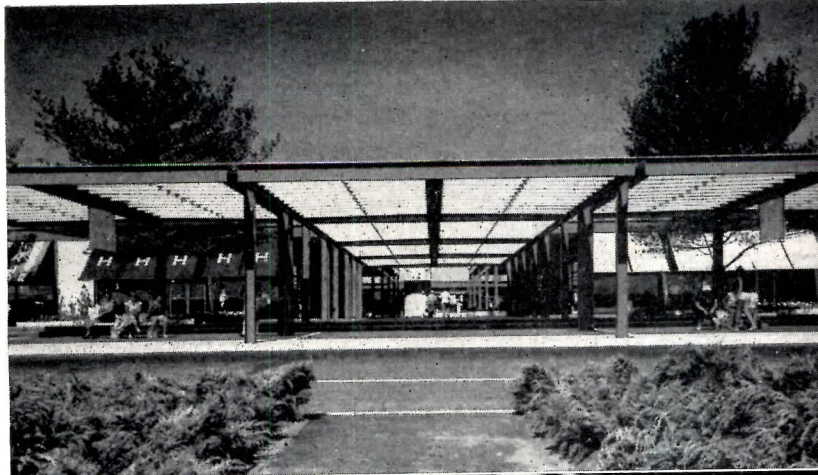

1

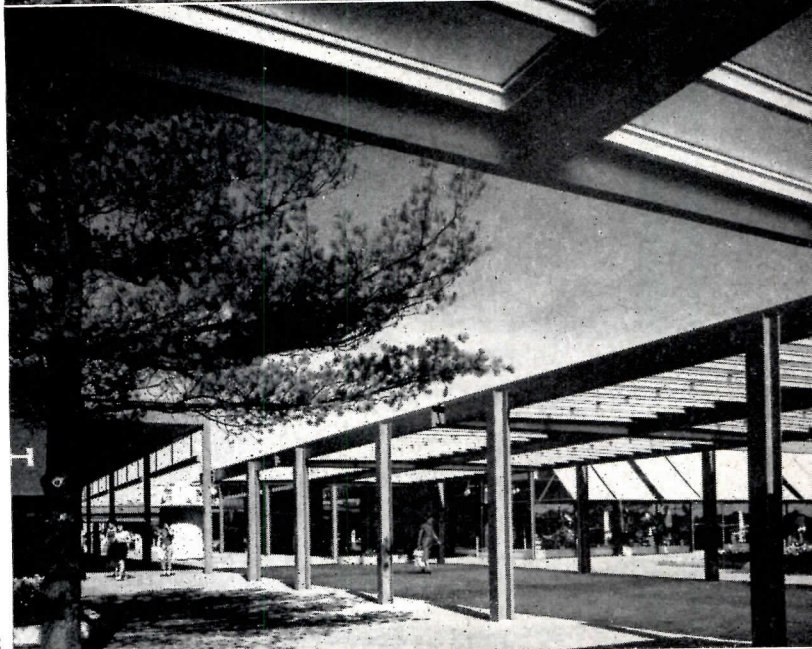

2

**ROOSEVELT FIELD:**

The Flight Mall, left page, extends from Macy's store north to the skating rink. The multi-colored flags were designed by Kenneth Resen, of I. M. Pei's graphics department.

The bus terminal, 1 & 2, is attractively sheltered by wire glass panels in aluminum extrusion surrounds held by the dark brown steel framework. The architect's graphics men designed the parking identifiers in varying gay colors, 3; the shopping bag, 4, with orange balloon, black letters; and the entrance sign, 5, consisting of 40-in. white plastic globes, inside lighted and with black letters. The 4-in. aluminum tube supports — just erected — will soon have their bases hidden by spreading plants.

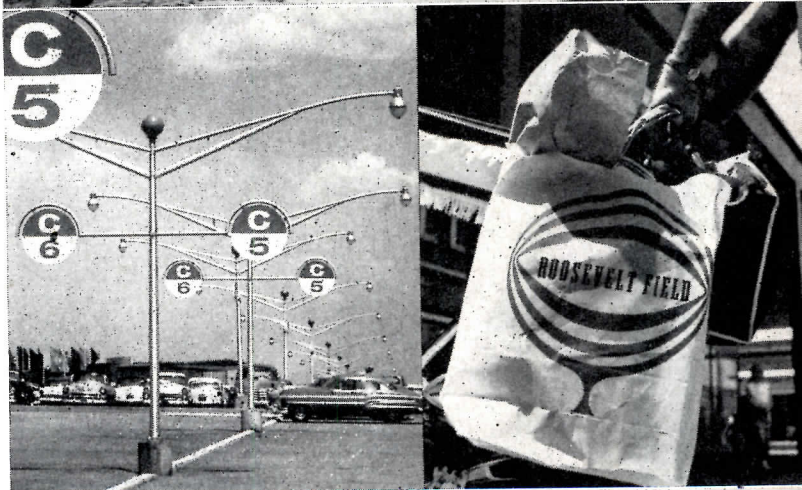

3, 4

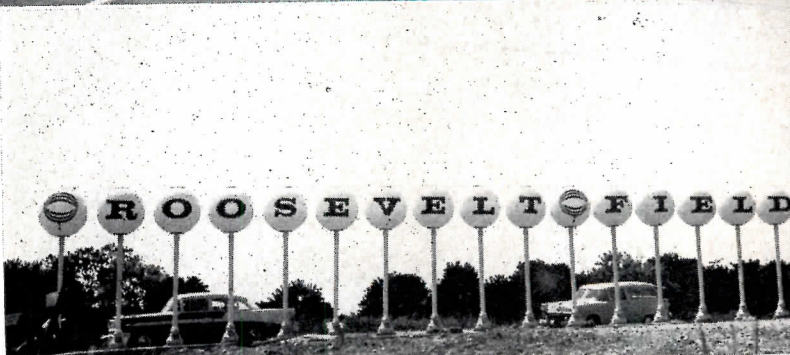

5

All photos by © Ezra Stoller except 3, Dominic Arbitrio; and 5, Robert Slutsky







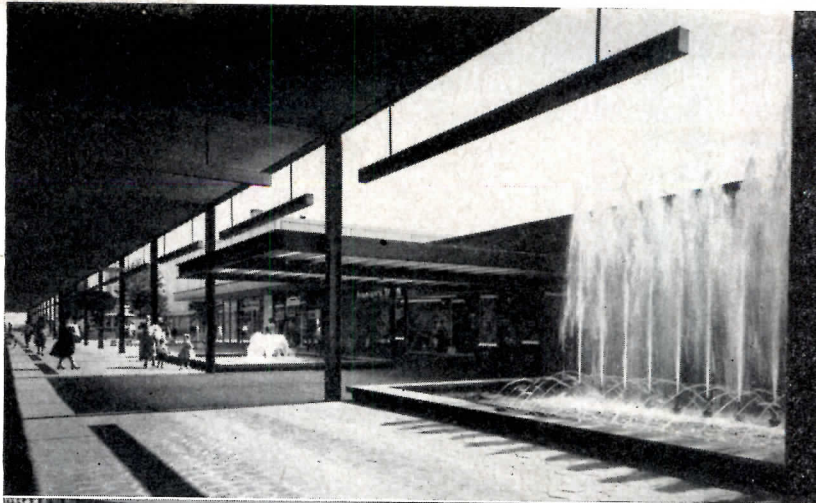

6



7

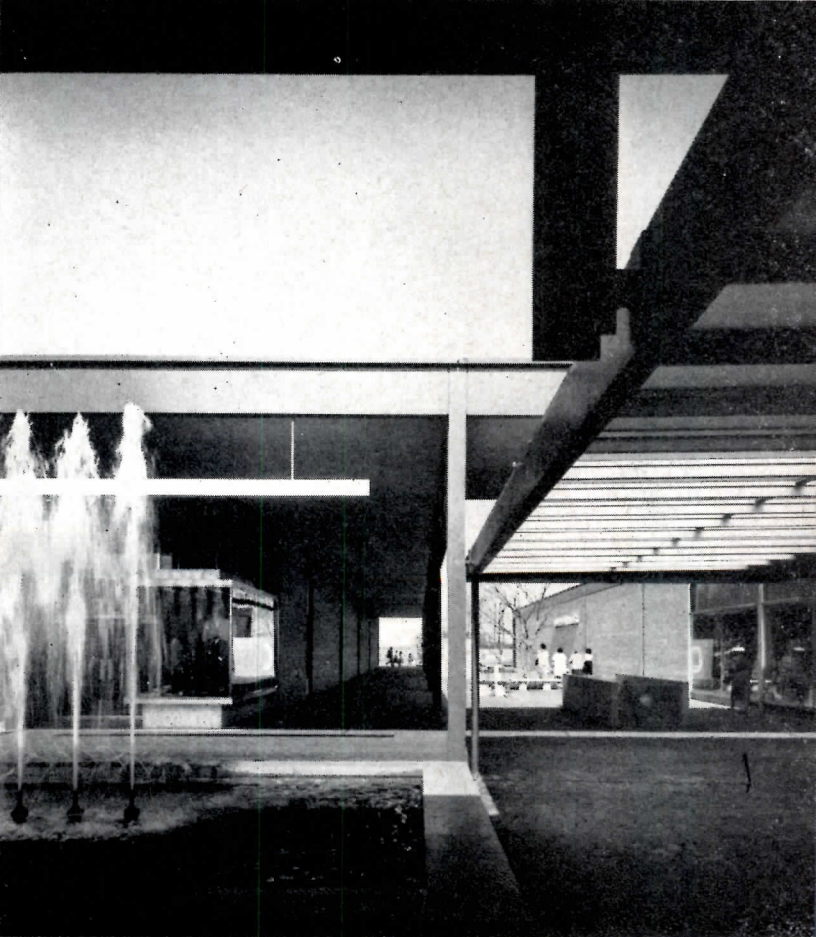

8

All photos by © Ezra Stoller

**ROOSEVELT FIELD:**

The Fountain Mall — shown variously in 6, 7, 8, and on the left page — features two types of fountains along its length; the squatty mushroom and the row of high jets. All fountains in the center use a total of 2200 gal. of water per minute, 25 per cent of which passes through diatomaceous filters to be recirculated. In winter, the water is tempered by special heating units. Before final installation, various experimental setups were made in order to study nozzle sizes and flow patterns. For nighttime use there are amber, blue and green underwater lights, controlled by rheostat. The tanks are welded steel construction, painted blue; the curbs are of stone.



cy's

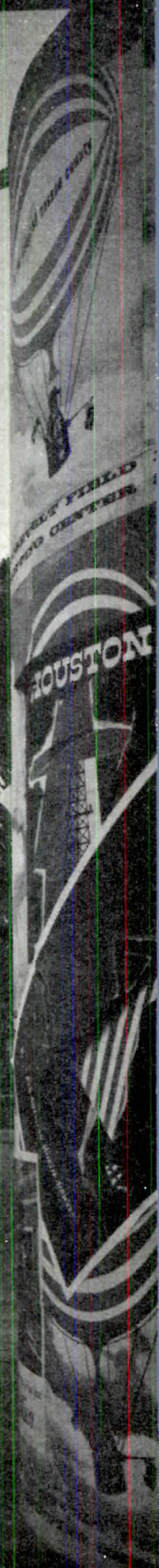
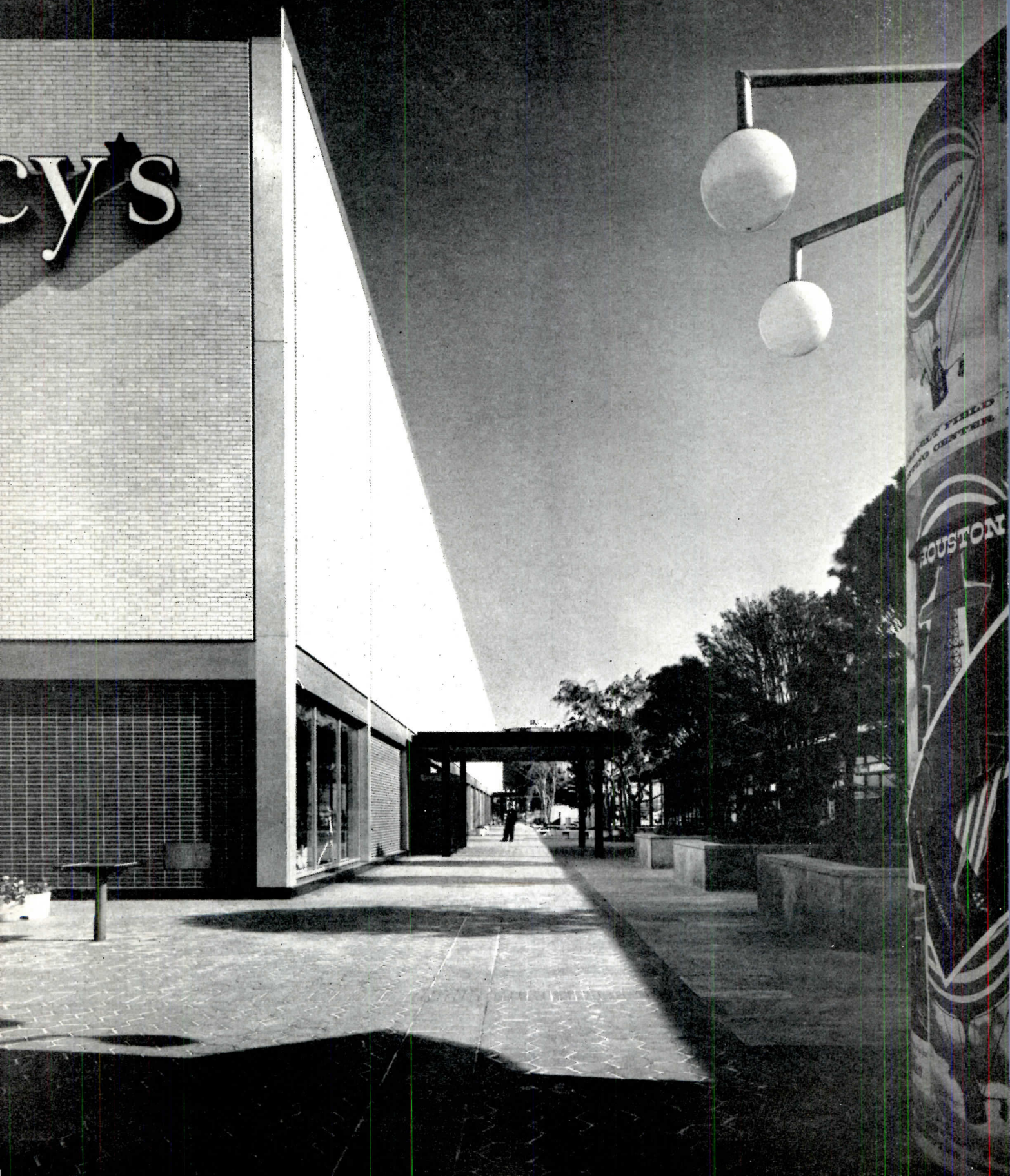



9

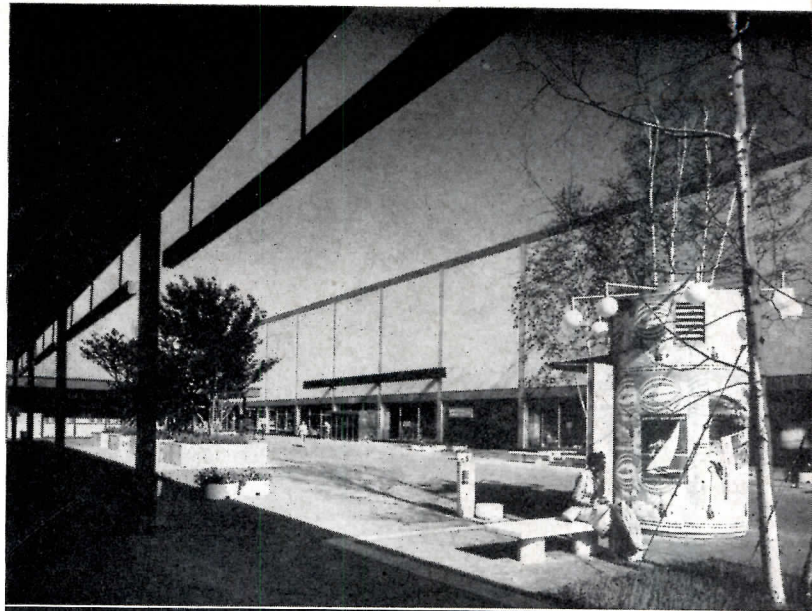

10



#### ROOSEVELT FIELD:

Macy's largest suburban branch, designed by Skidmore, Owings & Merrill, is seen, **10**, through a pattern of weeping cherry trees; and **left page**, flanking the west mall with a typical kiosk in the foreground.

Ten kiosks spotted about the center, **9**, impart a delightful continental touch, and are — or have been — in use for key-makers, pretzel vendors, benefits, Air Force recruiting, and even for automobile insurance!

Electric stairways, **11**, lead to the lower level concourse, where there are 25 additional shops, rest rooms, center administrative offices, a radio broadcasting studio, a 400-seat meeting room for community use, a home building products display center and an art center.

11

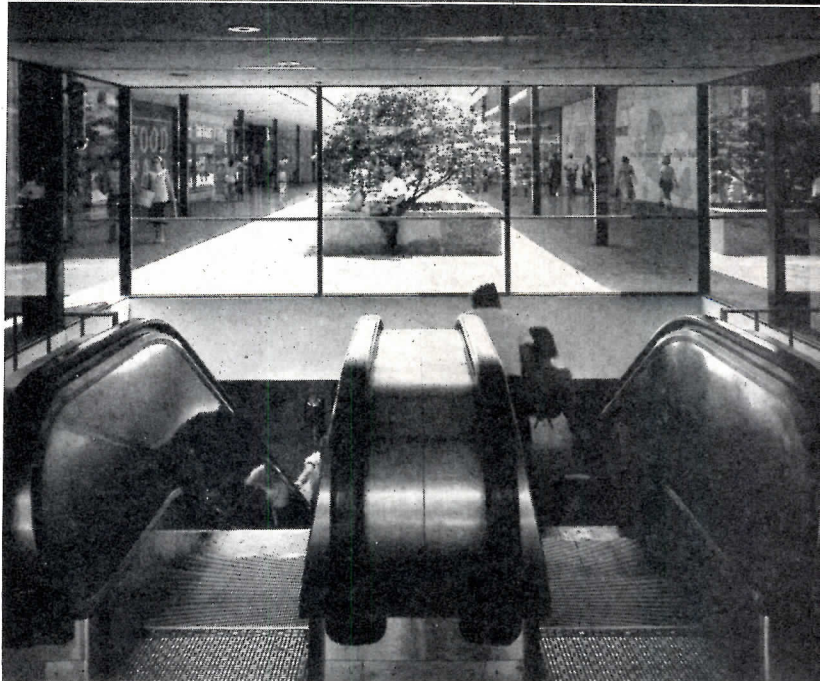

All photos by © Ezra Stoller









12

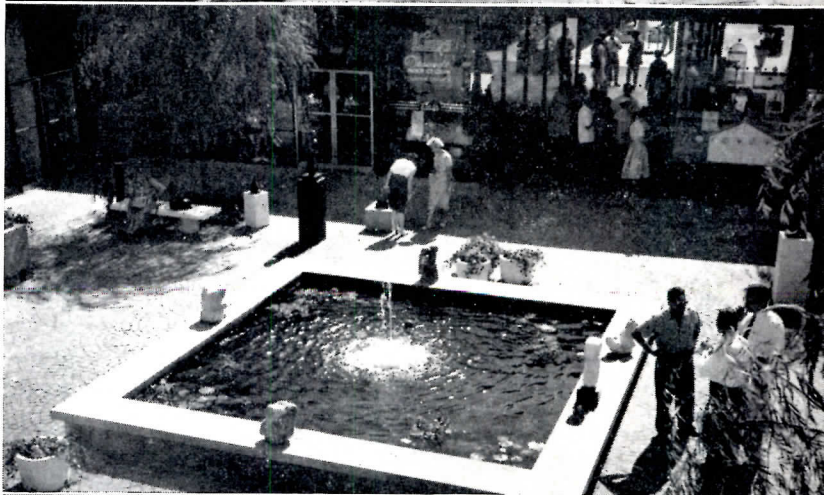

13



14

**ROOSEVELT FIELD:**

Typical of all the malls, the Plaza, **left page** and **12**, is paved with sound reducing 9-in. hexagonal asphalt blocks, ground to expose the bluestone aggregate. They serve as the field between divider strips of stone in a modular pattern that aligns with the modular pattern of the buildings.

The Continental Court, **13**, features a fountain with granite curb-bench and restful classical music from hidden sources.

The outdoor skating rink, **14**, is now being built and will open this winter.

There is a pick-up area for each of the supermarkets, page 216, following. The lettering is in primaries, black and white. The curved bench, variously used throughout the center, is precast concrete.

All photos by © Ezra Stoller



A  
M  
O  
K  
P  
A  
R  
E

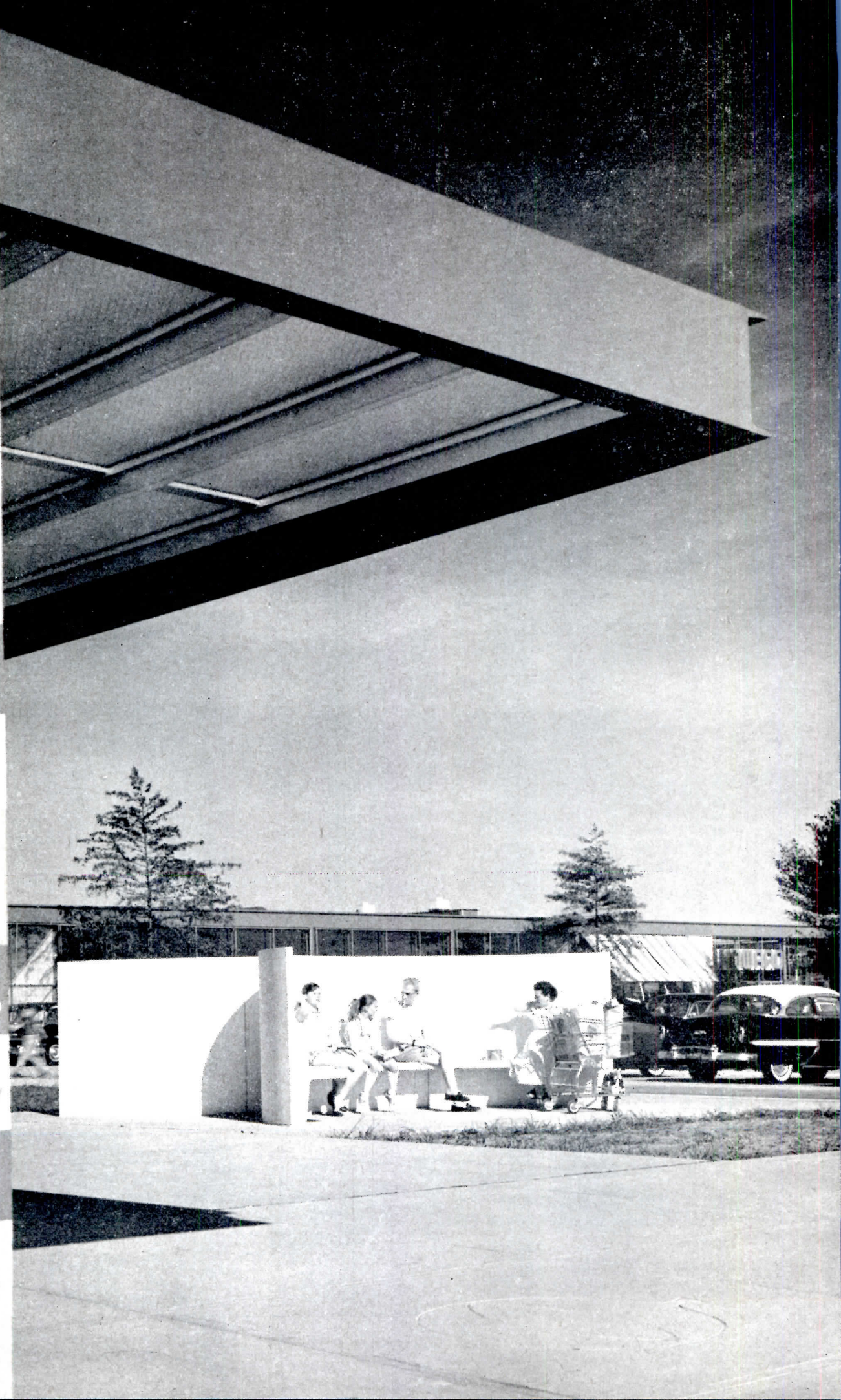



# Random Observations on Shopping Centers

## AND PLANNING FOR PEDESTRIANS

BY RICHARD M. BENNETT, Architect \*

SHOPPING IS DEFINED as "looking at, pricing, or buying merchandise displayed for sale."

While the success of a shopping center is measured by the magnitude of the buying therein, one must not forget that — varying with the type of merchandise — the *looking at* and the *pricing* are the foundation of the *buying act*.

Foodstuffs, laundry items and other standard things used every day — widely advertised and with narrow price variations — can be sold in a Buying Center. Here, the main design problem is easy and convenient access to demand merchandise — essential items which *must* be bought periodically. Once attracted, the captive buyer can then be exposed to impulse items which, when *looked at*, are often purchased, if the *pricing* is attractive.

On the other hand "Big Ticket" merchandise (more expensive and important) demands different handling, and here is the real difference between a Shopping Center and a Buying Center; for being bigger is only one factor. A Shopping Center is a place where one goes to seek, to look at, to find, compare, price and buy, and the implication of the adventure of finding is an important ingredient.

### On Shopping Itself

Looked at in broader terms, Shopping is a Social Ritual. The wife and homemaker charged with the wise spending of the family income must be given the sense that she has *worked* at seeking out and discovering a uniquely right article at a justifiable price.

It is not enough to have important purchases merely available. They must be as available as possible but in an atmosphere that suggests the culmination of a quest.

A Shopping Center can, and should have a number of terminal atmospheres. For example, one appliance selling area could be bright, overwhelming in range of stock and suggesting that things must be cheap because there are so many of them. Another location could display the same products with different lighting and greater spacing so that quality is stressed and the uniquenesses and features of products emphasized.

Above all, the opportunity must be given to *compare*. What can one get for a little more — or a little less money? Does one want the red one — or should one take the sensible black one? What does the other store have — how does it differ?

The larger shopping center is relatively more successful today because it can offer a deeper selection of merchandise at a wider range of prices than is possible in a smaller center.

Actually, shopping centers are not an entirely new phenomenon. A glance backward in history and some off-beat observations at other less recognized



\* Who also made these delightfully spontaneous sketches in the margins of a rough draft, with no idea they would be published. (Ed.)



merchandising arrangements might be stimulating in evaluating the present — and in looking ahead.

### Village Plans

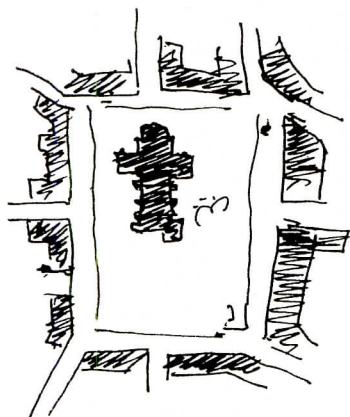

Thomas Sharp, the English Town Planner, tracing the development of the English Village through obvious crossroad, ferry and Roman legionary camp origins, failed to discover a village along a simple, straight road. Surprisingly, though, there *are* villages established along curved roads when the curvature is such that one cannot look *through* the settlement.

Towns built around open squares, often stemming from the Roman occupation, are interesting in that very often the advent of Christianity found the church built in a corner or end of the open space so that it terminated the principal streets leading to the square. Perhaps more importantly the church or cathedral site prevented views *out* of the square. There is evidence, too, that other streets leading outward were allowed to bend and curve so as not to invite one to leave the center. For the merchants with shops ringing the square, the church obviously blocks a number of views towards their individual establishments, but this is more than offset by the fact that when one is near their shops there is less distraction from other stores. The attention of potential customers tends to be concentrated upon the nearest shops.

### Amusement Parks



Though a neglected chapter in architectural history, amusement parks are excellent merchandising complexes because most people spend more than they intend in these ingenious layouts. The typical arrangement seems to be a meandering closed ring which returns on itself so that one starts a second circuit before one realizes it. While at first glance the informal layout may appear "Parklike" in character, the looking-around-a-corner process lures one forward and — at the same time — by shortening and limiting the view, as in many villages, concentrates one's attention upon the attractions most nearly at hand.

In pondering about the principles behind such plans, Coney Island, remembered as stretching straight along a beach, seemed to be a disconcerting exception. It is, of course, one of the most famous and successful of all amusement centers.

A trip there to check shows that it is not in reality built along a straight line, but is a great curved walk skirting a bay. As one promenades, the vista directly ahead is always dominated by shops and views into attractions.

One cannot help wonder what would have happened if the beach had been built on an outside curve around a headland instead of along a bay.

The famous Atlantic City boardwalk follows the same merchandising principles as Coney Island.

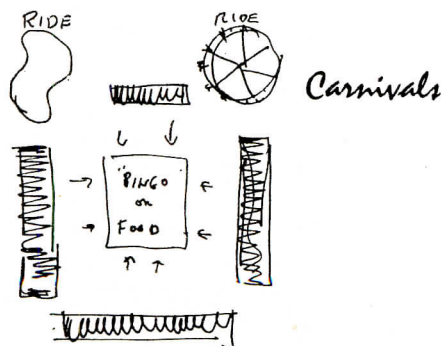

Much as amusement parks, carnivals are high-powered merchandising endeavors. Since they are assembled every week or so at different locations with changing components, they have a flexibility of arrangement that is responsive to practical experience. Conversations with carnival operators indicate that they are usually set up following the same principles as amusement parks, with a central attraction ringed by booths and secondary attractions including the "rides" in the corners. The central feature is such that it can be approached from all sides, and varies from a Bingo Tent to some sort of food concession.

### Department Stores

The highly developed interior planning of department stores may seem haphazard at first glance but the change of pace, space and direction — the informal arrangement — represents hard-headed thinking and experience. If certain principles work within the store, then they must have application to the



spaces *between* buildings if the shopping adventure is to be a unified, total experience.

## Streets—The Limited View

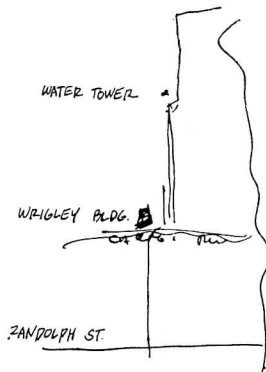

Could it be that most great shopping streets curve, bend, are short, or somehow establish limited views? For example, the Rue de Rivoli is straight but the massive piers of the enclosing arcade minimize the distraction of street traffic and the neighboring park.

One of the most entrancing and pleasant of shopping streets is Copenhagen's Stroget. Narrow and charming, it changes its name as it bends; opens occasionally into a square; presents a succession of visual changes. As one succumbs to the adventure, there is never a vista too far for understanding, and one finds himself hoping the street will never end.

Fifth Avenue in New York is a most famous shopping street — yet it is straight and it is successful — but is it? Actually, it has hardly settled down and has been travelling uptown these many years seeking a fixed point; some stabilizing element. Maybe the cross-axis at Radio City and the end-of-the-line at Central Park will stop its travel. We should realize that its success as a shopping area is probably based on the presence of many people who are there for a purpose other than shopping — such as business or sight-seeing. Our new regional shopping centers must, by the nature of their situation, create their own attraction.

Then there are streets with limited views and the smell of adventure which are not great successes as shopping streets — as yet. For example, Chicago's North Michigan Avenue is a highly attractive thoroughfare, especially when contrasted to its southern extension. Looking north from Randolph Street one's view is blocked by the Wrigley Building. Arriving near it and the Chicago River one jogs a little east and again the view is blocked, this time by the Old Water Tower. Again, jogging past that, the street stretches on until it opens into the lakefront. Its fascination is such that a walk along it is never tiring and one is apt to follow it further than he intended. Its potential as a shopping street is unrealized because of unused sites and lack of concentration.

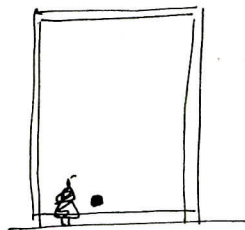

Scale

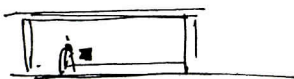

Architectural scale plays a most important part in relating customer and merchandise. It is sometimes difficult for architects to remember that a piece of architecture — the building — should be considered as a frame for the picture of the love affair between a customer and a piece of merchandise. When the frame is too big, the customer is apt to feel that both she and the merchandise are inadequate — too small — to consummate the attachment.

## The Future

As more large Shopping Centers are constructed and they begin to compete, which will be successful? Price competition, quality of merchandise competition, operational economies, and so on are important factors. But for the designer, all other things being equal, might it not be true that the architectural solution most sensitive to the psychological and social needs of the customers will have a final edge? Is this a lesson from the past and other contemporary merchandising plans?

The present day sees one disciplined straight-line mall or open strip development after another, most of them fairly successful. They tell all about themselves as soon as possible, and all the merchants are given an even break. Such schemes are rational, successful, convenient, efficient, smart, fashionable — but how many show human understanding and a love of adventure?

It remains to be seen whether or not the limited view, more attention to human scale, the lure of around-the-corner, the conscious creation of a sense of adventure will contribute to — or even be necessary for — the success of the evolving American Shopping Center. I think they will.







## GARDEN SETTING LENDS CHARM TO CHICAGO'S NEWEST CENTER

*A gratifying experience awaits the shopper at Old Orchard, for here one will find a center that possesses a personality peculiarly its own — one which is both charming and unusual. As one strolls about he becomes pleasantly aware of a scene that changes refreshingly — he finds change of pace, of scale, of direction, of shape, of surface. Yet underlying all is the basic unity necessary to wholeness. The lure of around-the-corner urges the shopper on, so he sees more merchandise than he otherwise would. Here is clever planning for business and a delightful environment for humans.*

The plan has as its center of gravity the Marshall Field & Co. store, with the professional building and The Fair department store as outlying anchors for the additional stores, service establishments, and restaurants. Study of the plan reveals an informal arrangement that provides, between the buildings, a series of spaces that expand and contract; that are sometimes contained but always continuing. One's view is constantly limited, but never confined.

The one-story buildings have structural steel frames on 20 by 40 ft bays, precast lightweight roof slabs, and brick exteriors; the department stores and professional buildings are framed in reinforced concrete on 25 by 25 ft. bays, have floor and roof slabs of poured concrete, and a variety of finishes. There is an underground truck tunnel for Marshall Field & Co. The entire project is air-conditioned. Heating and cooling comes from a central plant; tenants are billed on a unit cost basis.

1—Marshall Field & Co., 2—The Fair, 3—Supermarket, 4—Variety Store, 5—Drug Store, 6—Restaurants, 7—Office Building above, 8—Bus Platform, 9—Specialty Shops

### OLD ORCHARD SHOPPING CENTER

Skokie, Illinois

Owner: Old Orchard Business District, Inc.

Rental Agents: Draper & Kramer

Architects: Loeb, Schlossman & Bennell

Consultants: Landscaping, Lawrence Halprin & Associates; Mechanical & Electrical, Robert E. Hallis Engineers; Structural, Alfred Benesch & Associates; Civil Engineering, Joseph A. Schudt & Associates; Traffic Consultants, George Barton; General Contractors, Island Construction Co.

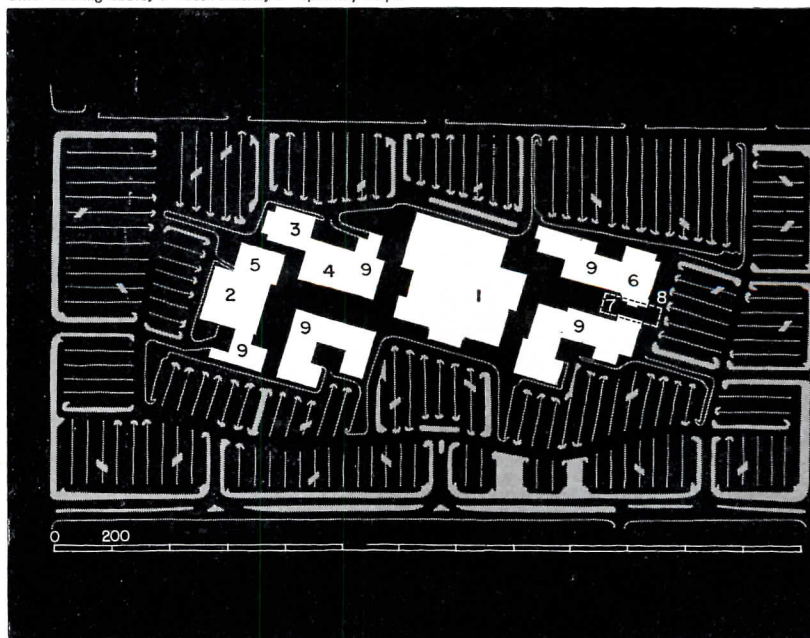

Photo, left page, Hedrich-Blessing





LEWIS SHOPS

A woman in a dress stands near a building entrance on the right.





1



2

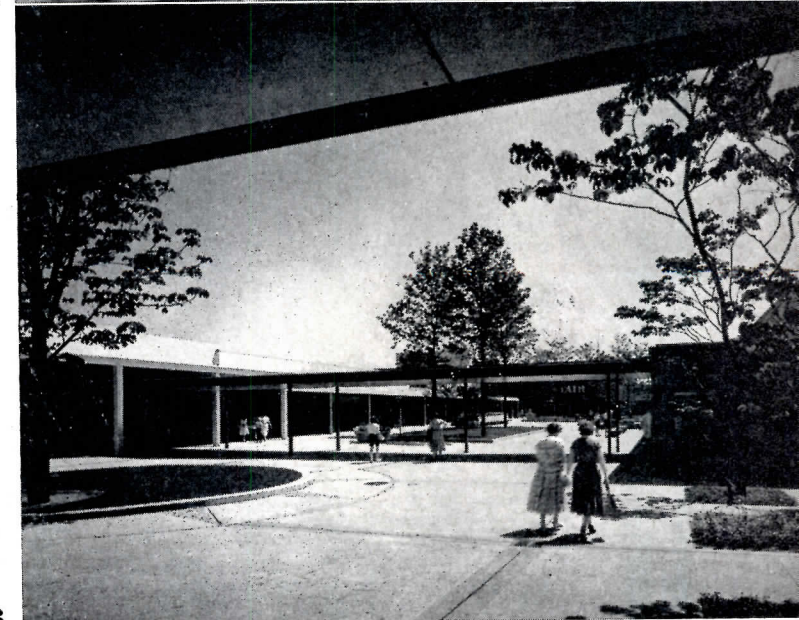

3

**OLD ORCHARD:**

Principal motor entrances are marked by the double-O symbol on white painted brick pylons, 1. The pylons act as identifiers rather than gates or closures; aid the driver in finding his way either in or out.

As one enters to the right of the Fair store, he walks into the mall, **left page**, leading to the supermarket. A backward glance, 2, with the Fair now at right, shows the fountain marking the turn into the mall at right angles leading to Marshall Field & Co. The fountain is of concrete and is underwater-lighted at night.

Throughout the center, the various buildings are linked by covered walkways, a typical example which is shown in 3.

All photos by Hedrich-Blessing







4



5



**OLD ORCHARD:**

Opposite approaches to the Marshall Field & Co. store, 4 and 5, are interestingly different both in scale and character. Passing through the professional building concourse, one comes upon the intriguing serpentine pool, **left page**, set within a protected court. From the Fair store, 6, the way is more open, larger in scale.

Though there are two basic building heights, (approximately 9 and 12 ft), one can note — in all the pictures — a pleasing continuity of canopy line throughout the center which serves as a unifying tie. Typical paving is concrete with exposed pebble aggregate, marked by brick strips in a modular pattern that aligns with the building modules.

6



All photos by Hedrich-Blessing







7

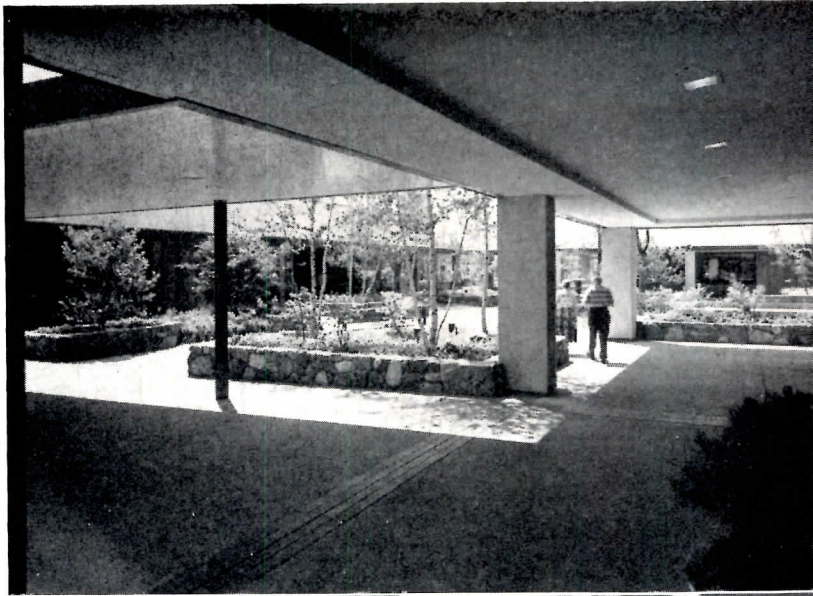

8



9



**OLD ORCHARD:**

The various courts adjoining the copper-roofed Marshall Field & Co. first floor, **7, 8, 9,** and **left page,** are charmingly landscaped. Low fieldstone walls form islands in a variety of shapes that serve effectively both to contain planting and to break one's line of travel (*cf* Bennett, pp. 217–219). The atmosphere here is pleasingly gardenlike and low pressure — but business is good!

The 7-story professional building, **left page,** is surmounted by the center water tank, which is clad in white plastic and which will carry, upon completion, the Old Orchard sign. The spandrels are light-colored brick; the strip fenestration is of fixed aluminum sash; the mechanical shaft is red brick.

All photos by Hedrich-Blessing







## SMART ADDITION ADDS STYLE TO SMALL CANADIAN CENTER

*Small shopping centers that are based on a plan idea that offers either a better arrangement for merchandising and service or shopper amenity — or both — are rare indeed. One is much more likely to encounter one of those depressing little strips — cheap, shoddy, and vulgar in character — that dot the highways everywhere. Here, in suburban Toronto, a passable but fairly undistinguished bent-strip has been given considerable style, a large measure of attractiveness, and a workable scheme for retailing by a well designed addition.*

The plan forms an angled U, with a separate road for service at the rear. Such a solution shortens walking distances and provides limited views that tend to hold the shopper's attention within the group. The new construction houses specialty shops which are disposed along both sides of a short, open-ended shopping lane that leads in one direction to the parking area and in the other to a garden court. The court becomes the plan hinge; links old and new; is the visual center of interest for the entire arrangement. An effort was made to relocate the highway along the outer edge of the parking area, but permission could not be obtained. Its location is disadvantageous, since it divides the parking space and must be crossed to reach the stores.

The original stores were having an indifferent financial success, but the addition has increased business substantially, more than offsetting construction cost, which totaled \$16 per sq ft.

1—Existing Supermarkets, 2—Existing Variety Store, 3—Existing Drug Store, 4—New Specialty Shops and Garden Mall

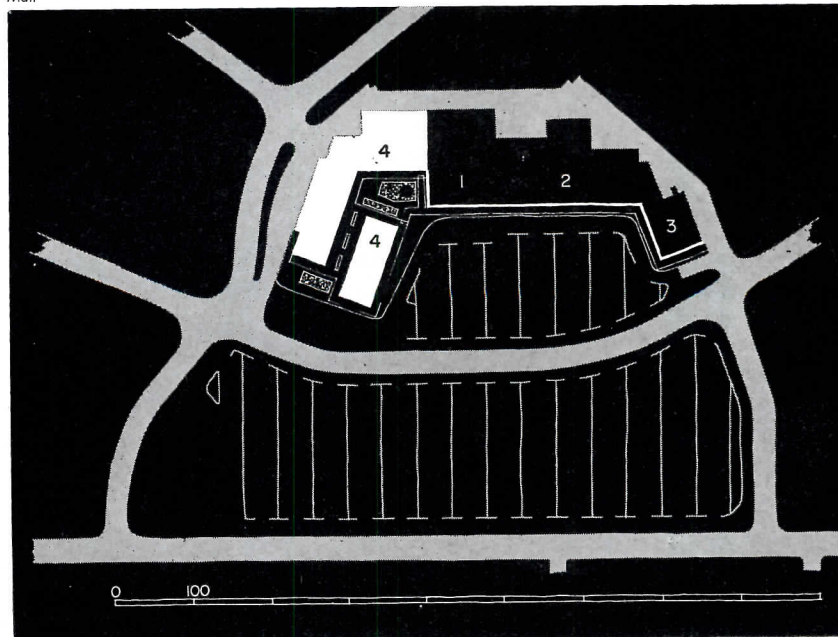

**HUMBERTOWN SHOPPING CENTER**  
Toronto, Ontario, Canada  
Owner: Consolidated Toronto  
Development Corp., Ltd.

*Architects & Engineers:*  
Victor Gruen & Associates  
*Associated Architects:* Hanks & Irwin

Photo on left page by Hedrich-Blessing









1



2

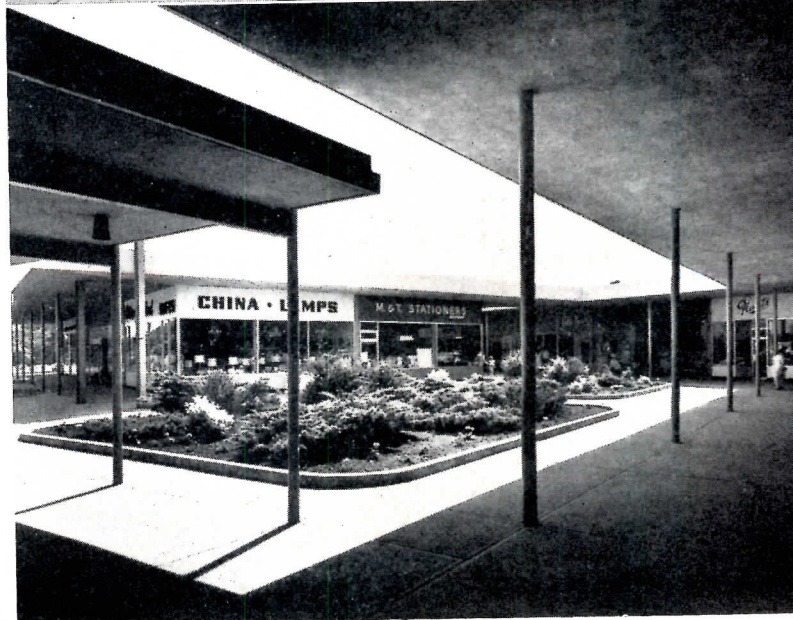

3

**HUMBERTOWN:**

The picture as one looks across the parking area into the U-shaped arrangement, 1, reveals the character of the existing stores, located in the foreground.

The new buildings are grouped about the double loaded shopping lane, 2, and the landscaped court, 3 and left page, which acts as a link between the existing and the new structures and also serves as an attractive focal point for the shopper.

All photos by Panda



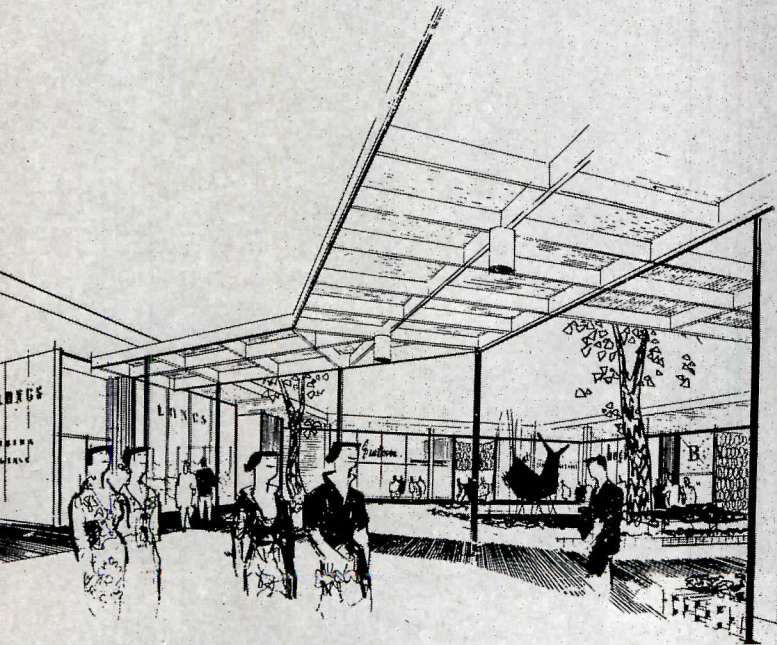
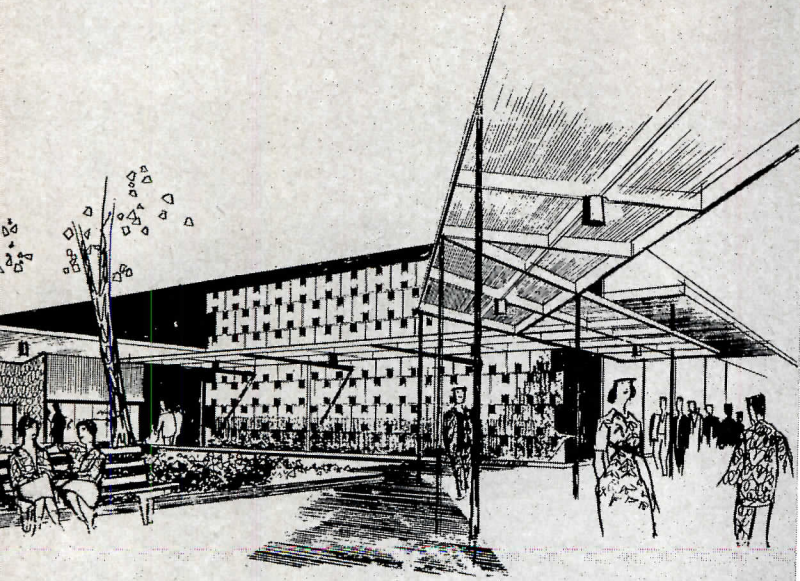



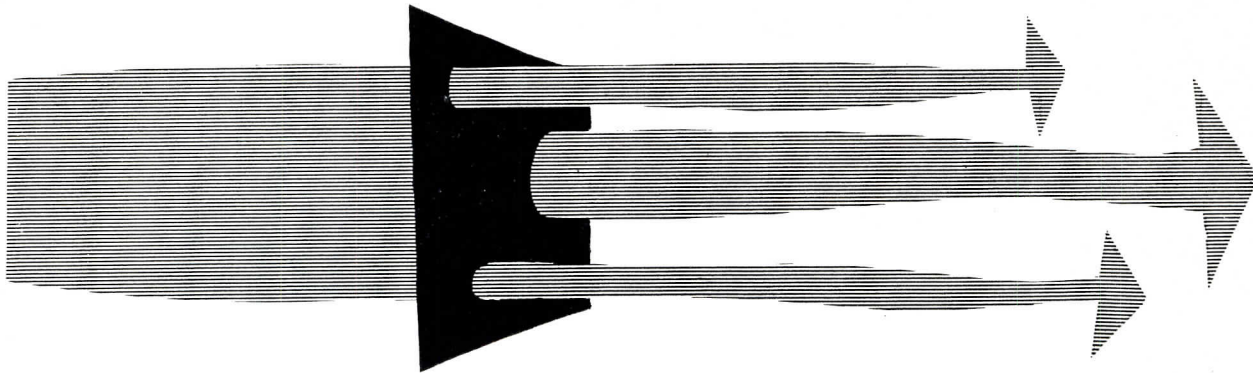

## Potentialities of High Velocity Air Conditioning

By F. J. WALSH, Consulting Engineer, New York City

*This is a guide to the various types of systems and their components, along with a discussion of how they work and some of the problems involved in system design*

IN AN AIR CONDITIONING installation, the system cost is affected mainly by the analysis of the practicable means of distributing the cooling effect to produce required temperature and humidity conditions and insure flexibility in system operation. This involves detailed system analysis and an engineering economy analysis of alternate possibilities.

Today, the solution to the problem of limited space for system installation necessarily requires that the high velocity air distribution be considered in those portions of the central duct system where space is critical. The use of higher velocities and system pressures can be combined with the use of colder supply air in a high temperature differential system (see Terminology) to achieve maximum space savings using only air as the cooling medium. Even greater space savings can be achieved by distributing part of the cooling effect to the terminal air handling units using

water. The least space of all would involve distributing water alone, with only provision for minimum ventilation air, but this would involve excessive use of mechanical refrigeration.

### Definition of High Velocity

"High velocity" air conditioning systems will be considered as including those systems in which all or an important portion of the air supply system has been designed to transmit air at such pressures and/or velocities that special flow regulating devices and/or sound absorbing means are required to reduce the sound level within the occupied spaces to an acceptable level. At the terminal ends of the "high velocity" duct, air valves and attenuating devices must be provided to reduce the velocity, pressure and noise to an acceptable level. The exact noise limits will depend upon the allowable sound levels for the particular type of occupancy.

In general, the term "high velocity" will include most of those systems in which duct air velocities are above about 2000 ft per minute and/or the duct air

pressures are above about 2 in. of water. The above definition includes not only "all air" systems but those systems in which only ventilation or primary air is supplied to the terminal units or terminal outlet units (see Terminology) with the balance of the cooling or heating being done by coils within the units or by other means such as radiant heating-cooling panels, conventional radiation, etc.

### Development of High Velocity

In recent years there has been a gradually increasing demand for year-round temperature control on an individual basis. Previously separate radiation had been provided at the periphery and conventional low pressure duct systems were used to distribute air for ventilation or cooling, with limited zone temperature control provided using reheat or volume control.

Because peripheral heating and cooling loads are subject to the widest variation, an intermediate step in line with the "individual control" trend was the use of fan coil units (generally with separate ventilation air) and "all air"



# BASIC SYSTEM ELEMENTS AND COMPONENTS

## 1. Fan Silencer

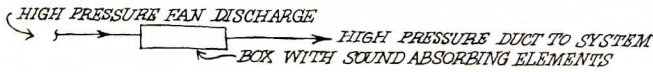

## 2. Duct Silencer

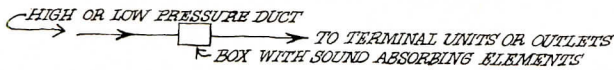

## 3. Air Valve

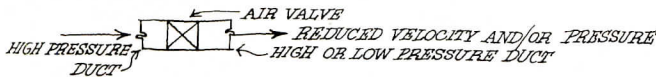

## 4. Duct System Static Pressure Regulator

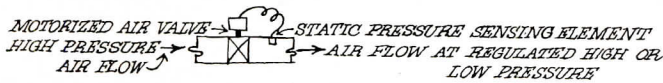

## 5. High Pressure Mixing Chamber

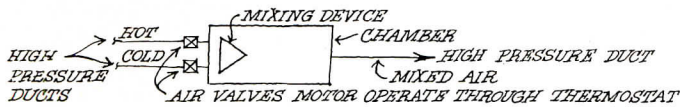

## 6. Terminal Air Units

Notes: (a) On high temperature differential systems low ratio internal induction type unit is used; (b) For arrangement of unit static pressure regulation (other than stable duct systems—where shut-off or volume control is needed) See Item 8.

### A. Terminal Attenuator Box

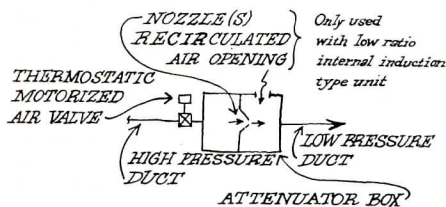

Note: Acoustically lined fan coil unit casing can sometimes be used also.

### B. Terminal Attenuator Mixing Box

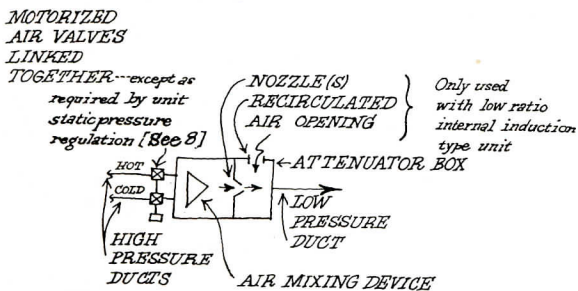

## 7. Terminal Air Handling Units (not standard)

Note: See Note 6(b)

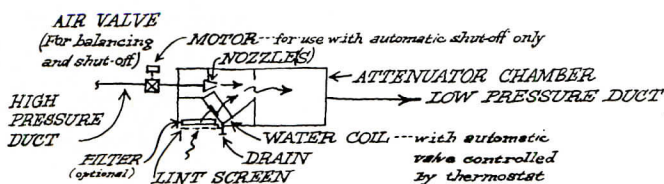

High Ratio Internal Induction Air and Water Terminal Air Handling Unit (Induction Air Handling Unit)

## 8. Terminal Air Unit Static Pressure Regulation Arrangements

(used with high friction duct systems only)

Notes: A Not used thus far. B present standard.

Single duct application:

A.—Similar; B.—(1) Not applicable, (2) Same as shown for cold duct control, (3) Same as shown for hot duct control

**A. Direct Method** (1) Regulation of pressure on high pressure side of unit air valve(s); (2) Reset of throttling range(s) of air valve(s) in accordance with static pressure on high pressure side of air valve.

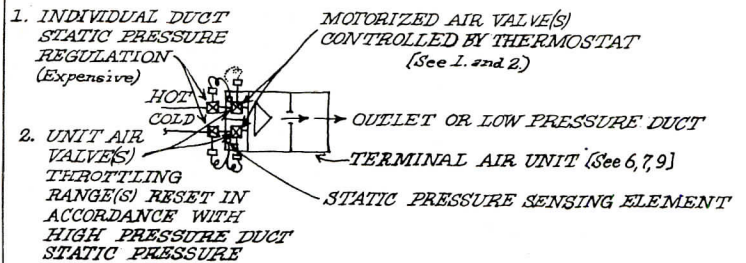

**B. Indirect Method**—Control of air valve or valves from volume of flow indication combined with control from thermostat (except constant volume single duct system).

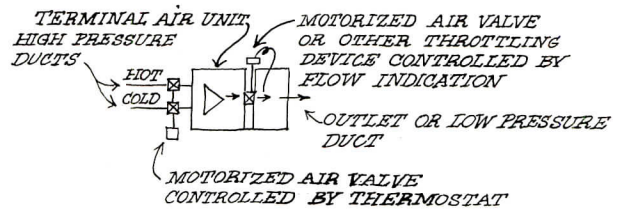

1. Thermostatic control of linked air valves plus mixture throttling

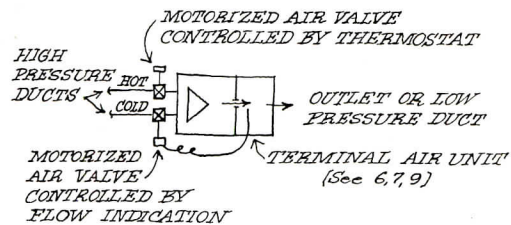

2. Cold valve throttling plus thermostatic control of hot valve (No positive control of total volume if design hot duct flow is large per cent of design cold duct flow)

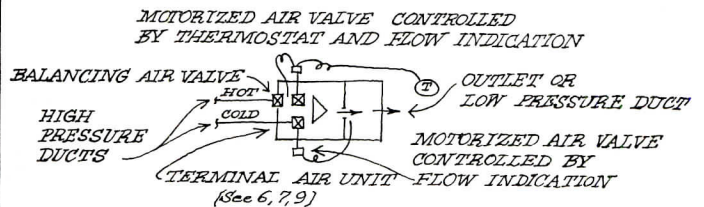

3. Cold valve throttling plus hot valve thermostatic control combined with throttling

## 9. Terminal Outlet Units See notes 6(a) and 6(b)

- (a) High internal induction air and water terminal outlet unit (induction unit)—Same as Item 7 plus outlet grille
- (b) Single Duct Terminal Outlet Unit—Same as Item 6(A) plus outlet grille or diffuser
- (c) Double Duct Terminal Outlet Unit—Same as Item 6(B) plus outlet grille or diffuser

General note: Air valves, high pressure mixing chambers, terminal air units, air handling units and outlet units can all be used satisfactorily with low pressure air.



## SINGLE DUCT ALL AIR SYSTEM

### 1. Notes—Pictorial Representation

(a) System shown is representative of that for a medium size multistory building.

(b) Intent is merely to give an approximate idea of relative space requirements.

### 2. Notes—Basic System Design

(a) Fans—provided with speed control or adjustment or variable inlet vane control, as demanded by required operating ranges.

(b) Fan Silencers—Number and location determined by duct layout.

(c) Duct System Static Pressure Regulation—As required by extent of terminal unit volume control and/or shutoff provisions.

(d) Duct Silencers—As required by installation details.

(e) Duct System Air Valves—As required for balancing or partial operation, or with duct system static pressure regulation.

#### (f) Double Duct Terminal Outlet Unit

(1) Standard unit.

(2) Low ratio internal induction type.

(g) Number and Location of Reheat Coils determined by zoning and system design.

### 3. Possible Basic System Design Modifications

(a) Combinations of reheat and Volume Control

(b) Air Supply to Terminal Attenuator Boxes supplying low pressure duct system.

(c) Use of high velocity return air system (fan silencer required).

(d) Shut-off of primary air to terminal units. Consideration has been given to this by certain manufacturers but application to date has been limited and analysis incomplete.

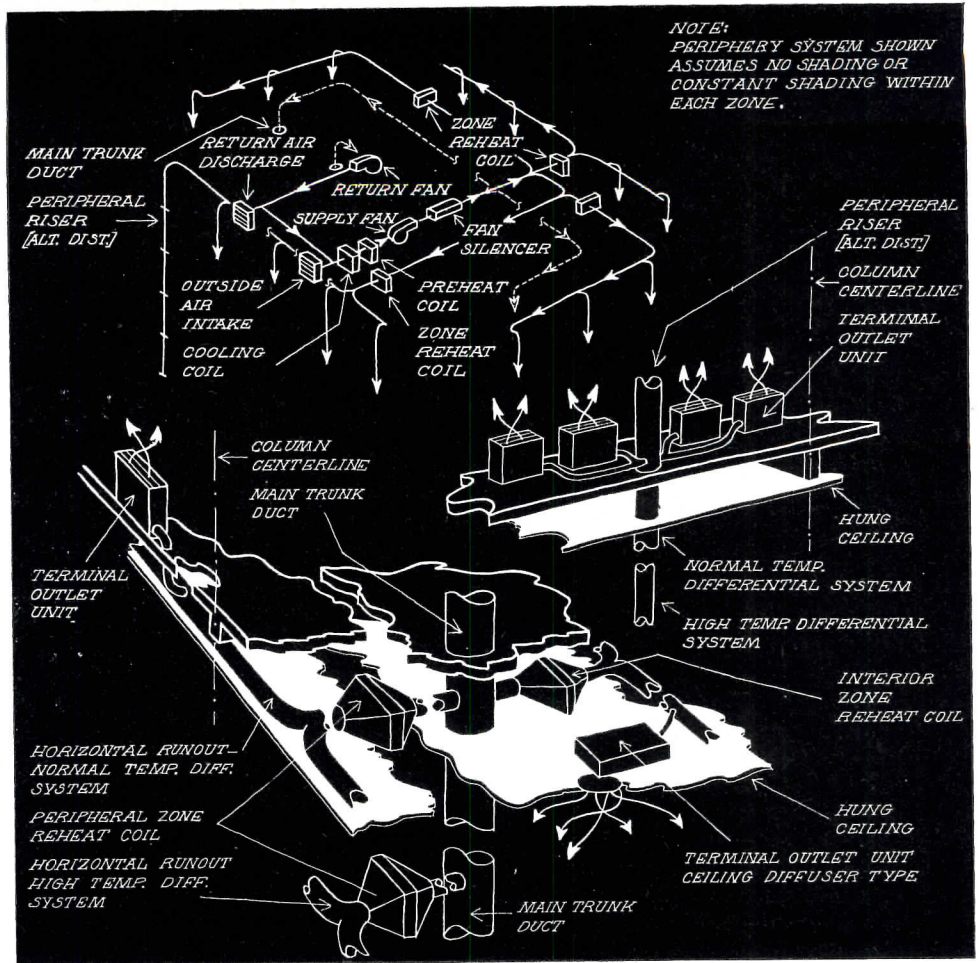

low pressure induction units, provided with a reheat coil and/or means for volume control.

To meet the increasing demand for reducing space requirements, while still providing individual temperature control, "high velocity" air distribution was introduced, requiring the use of high velocity terminal units using air valves (see Terminology). The terminal units developed were: standard all-air mixing units, air and water induction type terminal outlet units and single and double duct terminal outlet units. Most of these are employed on peripheral systems.

The latter have been termed "high velocity" type terminal units because of the timing of their development and because they have been used almost entirely on high velocity type air conditioning systems.

However, most of these high velocity type terminal units used today actually find their application at terminal pressures in the low pressure range (1½ in. s.p.), with 3 in. s.p. usually set by the manufacturer as a maximum.

Very often enough space is available so that the ducts can readily be designed for conventional low pressure—low velocity operation, and it would be economical to do so. Thus, if present standard "high velocity" units were used with lower pressures, the advantages of individual temperature control would be retained. It is unnecessary for present units to be redesigned for use at lower pressures, since any savings in cost for terminal units would be negligible. Actually, some high velocity system elements such as air valves have been used on recent low pressure school warm air heating installations.

### Relative Advantages at High Velocity

Regardless of the structure an architect may propose to build, it is generally possible to design an air conditioning system to give any reasonable set of conditions, if cost is no object.

High velocity in air conditioning has been developed to satisfy a basic architectural requirement, that of reducing space required for air conditioning ducts

and equipment to a minimum. This is particularly true with reference to peripheral duct shaft space in new buildings. Reduction in horizontal trunk duct sizes is another requirement although this is generally not as critical except where horizontal runouts are made to a peripheral "all air" system, since peripheral supply rates are high relative to the interior. What is just as important is the fact that the high pressure system allows greater centralization of air handling equipment where shaft space is limited, resulting in greater available rental space and lower average first cost.

Centralization is particularly important in a large multi-story office building or hotel. In the case of an office building, in an area where height is restricted by zoning, the use of high pressure air distribution may allow an additional floor of rental space on the same plot, (e.g. if all air peripheral system with horizontal runouts is used.) If limitations on duct space is a problem, it is generally possible to provide for future increases in capacity in portions of an air conditioning system more readily with a high



velocity system than with a low velocity system. Duct system stability would be required in either case.

While a high velocity system takes less space, it requires more expensive fans, sound attenuating treatment and air control devices, and ductwork (not always true) and requires more fan horsepower for the same volume of air handled.

### Factors Affecting System Selection

#### *General Considerations on Duct Design and System Stability.*

There is a wide variety of high velocity system designs possible and it is essential to best overall design that the engineer be given the maximum possible amount of space for risers, shafts and trunk ducts, since this will give him more freedom in design and result in a better, economical and more flexible system.

Even though the architectural concept of a building may dictate the use of a high velocity air conditioning system in certain areas, it does not mean that all parts of the system should be designed for high velocity.

It is possible to have a high pressure and a low velocity or a high velocity and a low pressure, as well as any combination of velocities and pressures, depending entirely on the design. However, the flow of air at high velocity results in higher friction which increases in geometric proportion with the velocity, greatly increasing required system pressure. Basically, the ducts should be sized to take advantage of all available space, particularly the branch ducts (since for the same velocity, friction will be in inverse proportion to the diameter). This will keep duct friction and system pressure at a minimum and make the system easier to balance.

Generally, it will be possible to use a stable duct system (see Terminology), although, very often this will require additional static pressure regulation within the duct system beyond the fan.

A high friction duct system (see Terminology) should be used only if there is no other alternative because of the greater cost of terminal units due to provision for static pressure regulation.

From the standpoint of ability to control air flow, it makes little difference, whether a system is a high velocity (high pressure) system or whether it is a low pressure — low velocity system, as long as a stable duct system is used.

However, high velocity air conditioning systems should always be designed taking into account the effect of static regain (see Terminology).

Without inherent stability (stable duct system) or built-in stability (high friction duct system plus terminal unit static pressure regulation), the system cannot be operated to allow terminal unit volume control or shut-off.

It is basic to any type of fluid flow (air, steam, water, etc.), to take a relatively large pressure drop across the final flow regulating devices with a relatively small pressure drop throughout the distribution system. Unless this is done there will necessarily be relative pressure unbalance within the system, which can result in considerable changes in flow at the terminal outlets whenever there are changes in flow within the system due to outlet shut-off or use of volume control.

An analogy can be made with the case of a water faucet in the upper story of a small building. When street pressure is high there is satisfactory flow at all outlets. When street pressure is low, the pressure and flow on the upper floors varies greatly. Faucets on the lower floors always have adequate flow, but any flow on the upper floors drops sharply whenever water is drawn on the lower floors.

Ordinarily duct pressures at the terminal outlet units which have volume control or shut-off will be greater than design pressure, because duct flow volumes are reduced below original design requirements, reducing friction drop in ductwork to outlets. Without terminal unit static pressure regulation, this would result in greater than design flow from the outlets. This in itself is not necessarily much of a disadvantage since the outlet itself (not terminal unit) could be selected to distribute considerably more than the design quantity of air and the thermostatic control would be relatively unaffected. Volume variation within limits is not objectionable if not accompanied by drafts or objectionable noise at the outlets. There would be more of a problem with reduced air flow, particularly with cold air.

### System Analysis and Design

It has been mentioned that there are innumerable high velocity system combinations possible — high velocity plus low velocity and high velocity primary air or ventilation air plus secondary

water coil. Any of these could be combined with reheat or booster cooling (see Terminology) to give various degrees of control.

High velocity air conditioning systems, excepting peripheral air and water systems (which are more or less standardized in design) can be exceedingly complex to analyze. There is considerable disagreement on basic considerations such as duct design, balancing and test, static pressure and volume control within the system, at the fan, and at terminal units. The design of "all air" systems cannot be standardized as with the air and water induction system. There are too many possible variations concerning location of system elements, fan and duct system static pressure control and the relationship of thermostatic control to fan and duct system static pressure control.

The engineer does not have complete and industry-wide accepted system design information, particularly on all-air systems. In such cases it is very difficult to come to positive conclusions. However, the engineer must investigate data on all aspects of design from every source, on a current basis, or he will not be in a position to do the best possible job for his client.

Where possible the engineer should specify in detail the operating performance of all elements of the system — noise levels, operating pressure limits, leakage, etc. Manufacturers of equipment specified should be asked to check design drawings to see that their equipment will work properly under stated conditions. Progress is being made on specifications regarding noise levels, but standards covering ratings and tests still require further study.

### Duct Location

The periphery is the most suitable area for application of high velocity air conditioning, since there is generally a far greater limitation on shaft space for ducts and pipes there. Also the least expensive method of distributing the cooling effect to peripheral terminal elements in a *multistory* building is by the use of vertical distribution shafts.

### Interior Zones

An important question today is: "How much actual need is there for high velocity air conditioning in the interior zones of a building?" In an office building, the cooling load for the peripheral zone, principally due to the highly variable



## AIR AND WATER PERIPHERAL SYSTEM

### 1. Notes—Pictorial Representation

(a) System shown is representative of that for a medium size multistory building.  
(b) Intent is merely to give an approximate idea of relative space requirements.

### 2. Notes—Basic System Design

(a) Fans—provided with speed control or adjustment or variable inlet vane control, as demanded by required operating ranges.  
(b) Fan Silencers—Number and location determined by duct layout.

(c) Duct System Static Pressure Regulation—As required by extent of terminal unit shutoff provisions.  
(d) Duct Silencers—As required by installation details.

(e) Duct System Air Valves—As required for balancing or partial operation, or with duct system static pressure regulation.  
(f) Terminal Outlet Units

- (1)—"Induction Unit"
- (2)—Terminal Attenuator box—Fan coil unit combination.

### 3. Possible Basic System Design Modifications

(a) Part of primary air supply can be directed to larger fan-coil air supply units, or to "induction air handling units," supplying a low pressure duct system and outlets.  
(b) Use of high velocity return air system (fan silencer required).

(c) Shutoff of primary air to terminal units. (Very little done on this at present.)

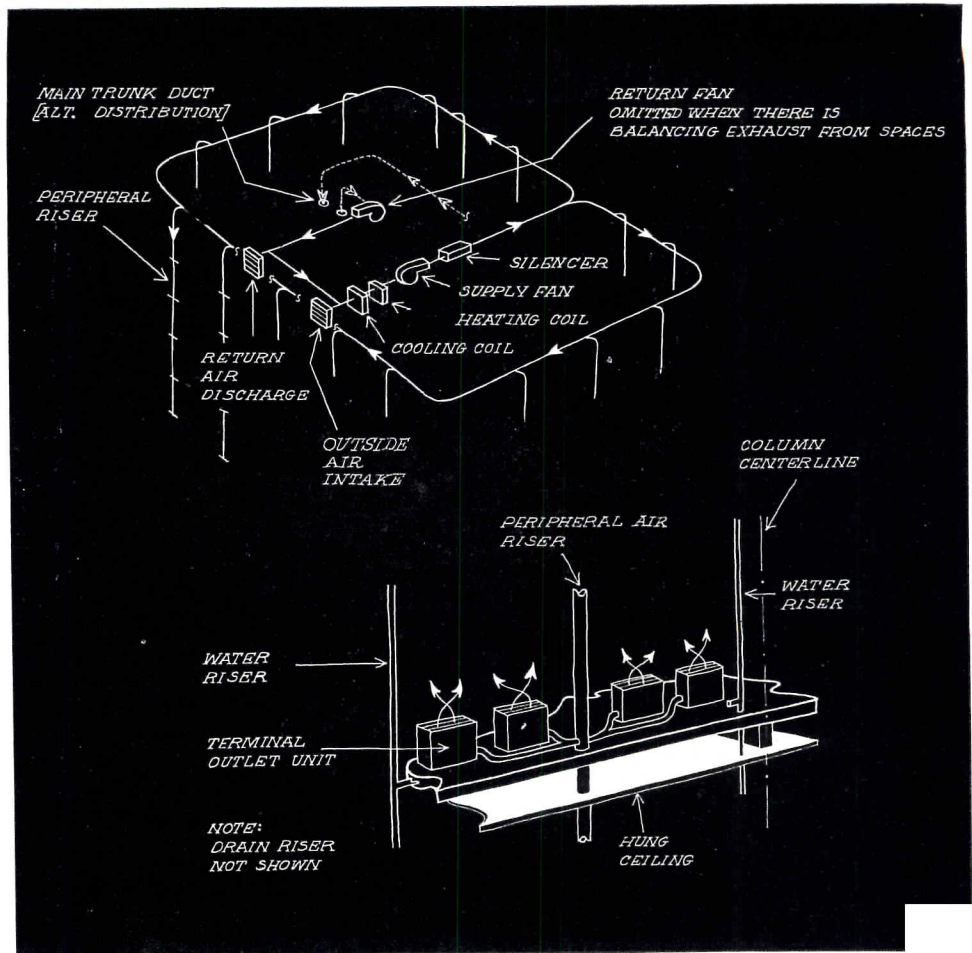

sun and transmission "skin load," is two to three times that of the interior zone, per occupied square foot. This means that the interior zones generally require relatively small supply air quantities and therefore duct sizes.

The relative importance and magnitude of the peripheral and interior air conditioning loads will determine whether they should be combined and to what extent. There may be theoretically unsound solutions resulting if they are combined, particularly in double duct all-air systems. For example, if the peripheral zone is used for heating in an all air system, the entire system would generally have to be run for all the spaces in all the unoccupied hours; in addition there would be added complexities in terms of system analysis, thermostatic control and system static pressure regulation. If there are more or less open floors with no closed in peripheral offices, there is the minimum chance of encountering difficulties when the zones are combined under one system.

#### Duct Shapes

The engineer has a choice of three basic

cross-sections (1) rectangular or square (2) round (3) flat-oval. The last has been used extensively in marine work and has promising possibilities. It has been used on some commercial jobs. The circular and flat-oval ducts can employ higher velocities than the square or rectangular without objectionable noise, due to air velocities and pressures since they have more freedom from buckling due to internal pressure.

#### Fan Noise

One of the most important design limitations of high velocity air conditioning is that of system noise. In many cases it is the actual limiting design factor. This is easy to see when one understands that the principal difficulty is with attenuation of low frequency fan noise (low frequency noise being more difficult to attenuate than high frequency noise). Total fan noise is proportional to the square of the fan system pressure and proportional to the volume of air being handled. Larger air volumes and higher system pressures are the inevitable result of greater fan system centralization. Therefore, maximum centralization,

when high velocity is used, results in the most severe fan noise problem.

#### Air Shut-Off

An item of major importance which seems commonly to have been overlooked in many current designs is that of provision for shut-off of air to unoccupied sections or floors of multistory buildings and provision for economical night time and off hours operation. There is no reason for assuming that high occupancy usage will always be the case.

#### Return Air

It is interesting to note that not only supply air, but also return air duct systems can be designed for high velocity operation. However, there is generally not too much requirement for this since the return shaft is always in the interior core of the building where more space is available.

#### Principal Types of H.V. Systems

The principal types of high velocity air conditioning systems used today are the following:



1. Primary Air and Water Peripheral Systems
  - (a) Induction unit systems.
  - (b) Fan-coil unit systems.
2. Single Duct "all air" systems.
3. Double Duct "all air" systems.

### 1. Primary Air and Water Peripheral Systems

In these systems a constant volume of cooled and dehumidified primary air is supplied to each terminal outlet unit to provide ventilation and/or moisture removal for the spaces.

These systems are designed primarily for peripheral zone application. Their minimum shaft space requirement allows maximum practicable centralization when vertical peripheral shafts are used. This gives a low first cost installation.

It is possible in a few instances to have the peripheral system also serve satisfactorily some interior areas and corridors when these are relatively small. However, this will depend on where system riser shafts are located with respect to interior spaces.

#### (a) Induction Unit System

This high velocity system was the earliest one to be developed and has had a very wide application. It is ingenious in concept and, if properly applied with respect to changeover point (see Terminology), represents a good economic balance between first cost and utilization of both air and water as the cooling mediums. The space saving achieved is at the expense of a lower changeover point, since the system employs water to handle part of the cooling load.

Generally it is economically unsound to attempt to use this system at changeover points below 45-50 F (for optimum annual cost). It would also be uneconomical to design for a changeover point much higher than about 50 F since the supply ducts would approach in size those of an all air system and the cost of the water system would be relatively high for what it would accomplish.

The system functions as follows: High pressure primary air (see Terminology), passing through a series of nozzles in the terminal outlet unit induces several times this quantity of room air past a secondary chilled water coil and delivers the mixture through the unit outlet to the conditioned space. The primary air quantity is sufficient to provide ventilation and all necessary latent heat removal. The secondary water coil system is designed to remove sensible heat

only, not moisture, and is controlled by automatic water valves under thermostatic control. The drain line from under the coil is sometimes omitted, but, since secondary air flow can be restricted or high moisture load operation be unavoidable at times, there is no guarantee that the coil will operate dry during all normal occupancy periods.

On the summer cycle, as a minimum, the cold, constant temperature primary air supply has the capacity to handle the moisture and transmission loads. The secondary water coil handles load due to sun, lights and people.

At the "changeover point" cool primary air plus negative transmission just offsets the load due to sun, lights and people.

At outside temperatures above the changeover point, reheated primary air offsets negative transmission.

Below the changeover point, cold primary air is held at constant temperature and hot water is sent to the secondary coil to provide heating, with water temperature varied according to outside temperature. Cooling and heating are available at all times when needed.

### 2. Single Duct All Air Systems

These systems, basically, are an extension of the use of conventional low pressure, low velocity systems, and quality of performance is similar. During the cooling season they may be unable to produce satisfactory humidity conditions in diverse zones unless the primary air temperature is maintained constant and combined with zone reheat.

Where volume control only is used as a means of control for zones or individual spaces, the system is limited by the possibility of unsatisfactory air distribution and reduction in required dehumidification. This objection can be overcome by limiting the maximum percent reduction in volume and using reheat for control beyond that point — limited reheat system (see Terminology). In addition, if total system load at any particular time is considerably less than system design load, there may be complicated problems in fan control and performance, noise levels, static pressure control, system unbalance, etc.

The allowable per cent reduction in volume at any terminal outlet unit during normal operation would depend on the supply air temperature differential and the performance characteristics of the outlet. Minimum volume should not be so low as to cause a feeling of stagnation or to provide inadequate ventilation.

### 3. Double Duct All Air System

These systems, since they distribute a maximum amount of primary air, will always result in an installation having a higher changeover point than is possible with the air and water systems, reducing required operating hours for the refrigeration plant. In addition, since heat is always available in the hot duct when needed, provision for heating and for cooling for any zone or terminal unit is simple and automatic.

Accurate control of temperature for any number of spaces desired will always result with any double duct system. Limitation of maximum humidity in any space under varying load conditions will necessarily require the use of reheat, and, even though any double duct system acts as a limited reheat system, the design should keep the use of reheat to a minimum so as not to be wasteful of refrigeration capacity. In the double duct system, application of reheat depends on analysis of zoning requirements and reset of zone hot duct temperatures. Proper analysis of this can be difficult.

System design is complicated because of several factors:

(a) Diversity of loads due to centralization and zoning may be great and a calculation of actual room humidity conditions resulting from mixed air supplies in the rooms has to be made on a trial and error basis which depends on assumptions as to how hot duct temperatures will be controlled. It would simplify design analysis and prediction of resulting room conditions if all hot duct and cold duct supply air were dehumidified to the same point but this would require additional refrigeration capacity. This problem is important not only from the standpoint of being able to calculate satisfactorily total building load but also from the standpoint of system analysis. Well thought out standard procedures need to be established which will simplify this analysis. For interior zone loads such as in an office building, the loads are relatively constant and analysis is greatly simplified.

(b) It is a volume control system so far as both hot and cold ducts are concerned. System stability, outlet noise and required static pressure control will depend not only upon proper duct design and terminal unit selection for maximum flow condition in each duct, but the effect of hot duct temperature reset control (see Terminology) as determined by system analysis. Built-in static pressure regulation at each ter-



## DOUBLE DUCT ALL AIR SYSTEM

### 1. Notes—Pictorial Representation

(a) System shown is representative of that for a medium size multistory building.

(b) Intent is merely to give an approximate idea of relative space requirements.

### 2. Notes—Basic System Design

(a) Fans—provided with speed control or adjustment or variable inlet vane control, as demanded by required operating ranges.

(b) Fan Silencers—Number and location determined by duct layout.

(c) Duct System Static Pressure Regulation—As required by extent of terminal unit volume control and/or shutoff provisions.

(d) Duct Silencers—As required by installation  
 (e) Duct System Air Valves—As required for balancing or partial operation, or with duct system static pressure regulation.

### (f) Single Duct Terminal Outlet Unit

(1) Standard unit

(2) Low ratio internal induction type

### 3. Possible Basic System Design Modifications

(a) Supply to high pressure mixing chamber distribution same as single duct all air system.

(b) Air supply to terminal attenuator mixing box followed by low pressure single duct system.

(c) Use of high velocity return air system (fan silencer required).

(d) Shutoff of primary air to terminal units. Consideration has been given to this by certain manufacturers but application to date has been limited and analysis incomplete.

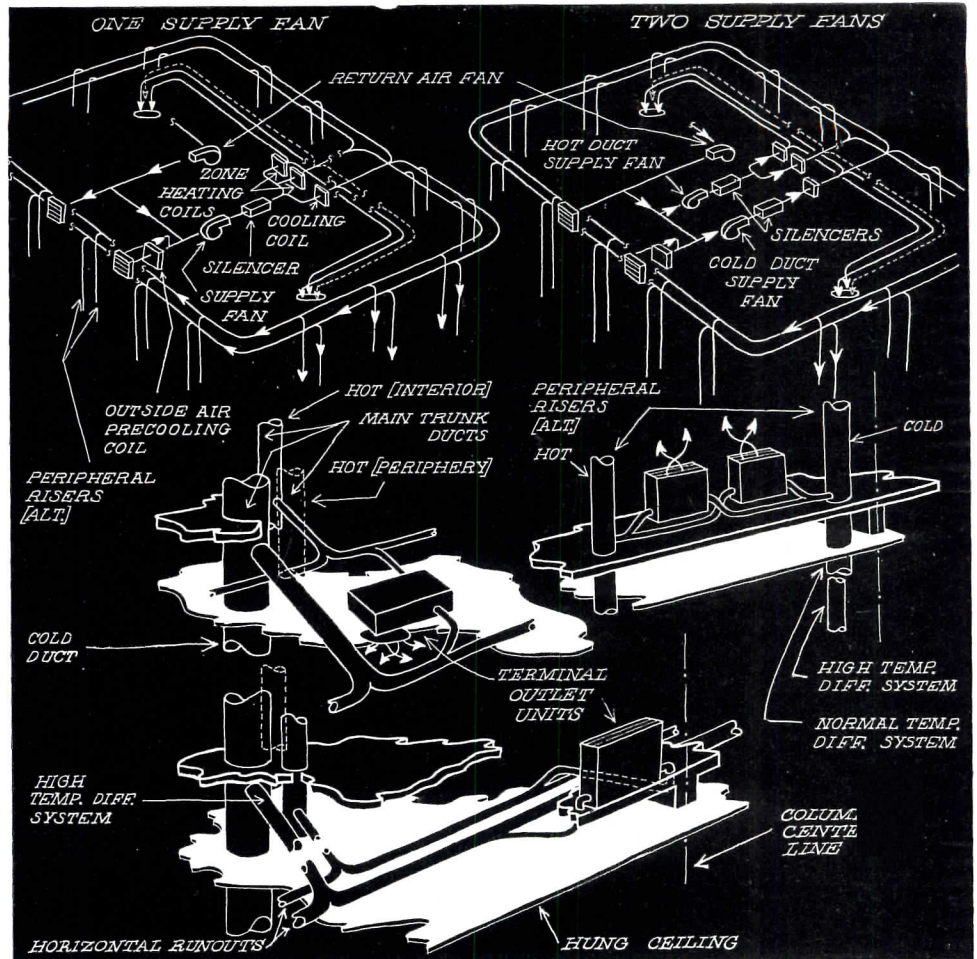

terminal outlet unit to achieve a constant volume of air from each outlet (referred to earlier in this article) has been introduced to solve the problem of system stability, but there is some question as to whether this is the final answer.

(c) Because the system is a volume control system, there can be problems relating to humidity control and maintenance of minimum ventilation, depending on which basic system is used.

The following general statements can be made regarding the basic air cycle:

(1) Generally, where outside air moisture load is high and more than a very small per cent of outside air is used in the primary air, the outside air supply should be pre-cooled separately to bring its moisture content down at least to the level desired in the conditioned spaces, except where only recirculated air is used in the hot duct (interior systems only), or the entire mixture of return air and outside air is passed through the main duct coil (wasteful of refrigeration).

It would be advantageous in some cases to have a separately controlled booster cooling coil in the duct before

the hot duct heating coil to remove additional moisture without going to an extreme.

(2) Where it is desired to design a system with different changeover points (e.g. peripheral and interior zones, a two supply fan system must be used, so that 100 per cent outside air can be supplied to the zone requiring it. This system will be more complicated from the standpoint of system analysis, temperature control, and fan and static pressure control.

(3) Where zone loads vary considerably with respect to each other, either in terms of sensible heat loads (periphery versus interior) or in terms of moisture load (high occupancy versus low occupancy spaces), then separate zone hot duct reheaters may be necessary to maintain minimum ventilation (except in single supply fan systems) or to maintain satisfactory relative humidity conditions (except where system design provides low moisture level in the hot duct).

At the present time zone and system hot and cold duct temperature control is based upon an effort to stabilize the

total flow of air in the system, combined very often with the use of built-in static pressure regulation at terminal units to insure constant outlet flow (high friction duct system only), and reset of hot duct temperatures to vary average hot and cold duct air volume usage.

Volume and/or static pressure regulation at the central fan installation completes the picture.

### Present Status of Knowledge

The basic theories underlying the design of the various types of high velocity air conditioning systems, and suitable application engineering information regarding installation and operation of all of the various elements of the system, need to be further clarified so that detailed information is available, which would enable an engineer to readily analyze all possible types of systems and design the most suitable system to meet an owner's requirements.

Engineers should consider information from manufacturers on total system design as an aid in developing their own design for an installation, rather than as a complete analysis in itself.



## HIGH VELOCITY TERMINOLOGY

*Air Valve* — a throttling device which is specially designed to reduce air velocity and pressure, generally against high pressure differentials, with a minimum of noise.

*Air Outlet* — any opening through which air is delivered to a space to provide heating, cooling, humidification, dehumidification or ventilation.

*Air and Water System* — system in which two cooling mediums, air and water are distributed to the terminal units.

*All Air System* — system in which air is the sole cooling (heating) medium to the terminal units.

*Air Mixing Device* — device to thoroughly mix two air streams within a plenum.

*Attenuation* — sound absorption.

*Attenuator Box* — an acoustically lined box.

*Booster Cooling Coil* — a secondary cooling coil used to provide additional zone cooling (when required by a more demanding load).

*Box* — a standard factory made or designed plenum.

*Chamber* — a non-standard factory made or designed plenum.

*Change Over Point* — the outside temperature at which maximum use of outside air quantity in the system can handle the entire cooling requirements of the zone with zone refrigeration shut off.

*Constant Volume System* — system in which the air supply to each terminal unit is designed to be approximately constant when the unit is in operation.

*Damper* — a throttling device, with one or more pivoted adjustable blades, used to regulate air flow (not suitable for use on high velocity systems because of poor flow control and noise generating characteristics.)

*Duct Silencer* — a box containing acoustical elements designed to reduce noises at specified frequencies.

*Fan Silencer* — a box or chamber containing acoustical elements designed to reduce specified low frequency fan noises.

*Full Reheat Control* — Temperature control in which a constant quantity of primary air is supplied to the terminal units and reheat is added by a heating

element (eg. coil or electric heater) located in the zone air supply. (Maximum use of refrigeration)

*High Friction Duct System* — Any duct system other than a stable duct system.

*High Temperature Differential System* — system in which cold primary air (approximately 20–35 F. below space temp.) is distributed to internal induction type terminal units, because, without induction, the temperature from the terminal outlets would be too low for satisfactory distribution.

*Internal Induction* — the inducing of room air through a recirculation opening in a terminal unit caused by passing primary air through a nozzle(s), and the discharge of the mixture from the unit.

*Limited Reheat Control* — Temperature control in which the quantity of cold primary air to the terminal units is reduced in accordance with load to save on refrigeration, accompanied by (double duct system), or followed by (single duct system) the addition of reheat into the air stream, either by the addition of hot air (double duct system) or by the action of a heating element (eg. coil or electric heater).

*Mixing Box* — a box designed with components suitable for controlling the mixture of two air streams.

*Mixing Chamber* — a chamber designed with components suitable for controlling the mixture of two air streams.

*Normal Temperature Differential System* — a system in which standard terminal units are satisfactory (primary air temperature approx. 15–25 F. below room temp.), the minimum temperature being determined by the performance characteristics of the terminal outlets.

*Noise Level* — the amount of noise generated by flow of air past a device or by the operation of equipment.

*Nozzle* — a flow control device used to increase the velocity of a stream of water or air.

*Primary Air* — the ventilation air or conditioned air supplied directly to a type terminal air unit, terminal air handling unit or terminal outlet unit.

*Reheat* — heat added to the cold Primary air supply to a zone in order to

maintain temperature control. (Primary air cooled to temperature required for maximum sensible cooling or moisture requirements.)

*Reset Temperature Control* — adjusting supply air temperature on the basis of some condition indicating changing load requirements.

*Sensible Heat* — “dry heat” component of cooling load.

*Sound Level* — the total effect in a space of all noises contributing to the overall level.

*Static Pressure Regulator* — device actuated by static pressure sensing element, which acts to maintain desired static pressure in a portion of duct system.

*Stable Duct System* — duct system designed with relatively high terminal unit pressure drops so that changes in duct static pressures due to predicted flow changes do not result in air flow quantities from terminal outlets being outside of desired limits (may include limited duct system static pressure regulation).

*Static Regain* — the portion of the difference in velocity pressures, between a higher velocity point in a duct system (usually fan discharge) and some other lower velocity point (usually at terminal unit) which is actually converted to a gain in duct static pressure.

*Terminal* — final device in a system.

*Terminal Unit* — unit located within a high velocity duct system in which primary air is reduced to low pressure.

*Terminal Attenuator Box* — box within which primary air is reduced to low pressure.

*Terminal Air Handling Unit* — a high ratio internal induction terminal attenuator box, including a cooling coil, which is located within a single duct primary (ventilation) air system.

*Velocity Pressure* — the static pressure that would result if all of the energy due to air velocity in a duct were converted to equivalent static pressure.

*Zone* — the largest single space or group of spaces served by a system, the temperature and/or humidity control for which is accomplished by single set of controls such that conditions within the spaces do not vary outside of accepted limits.



*Heart of the 655-acre air traffic center now under construction at New York International Airport is the arrival group shown at right. Designed by architects Skidmore, Owings and Merrill for the Port of New York Authority, the group consists of an International Arrival Building with parabolic exit lobby (details below), Airline Wing Buildings housing the foreign-flag airlines, and an 11-story control tower*



Charles Payne

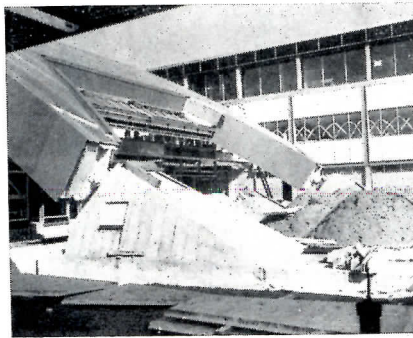

## NEW YORK'S "TERMINAL CITY:" A PREVIEW

THE ROAR OF GIANT AIRLINERS over New York City's International Airport is echoed by the hum of construction on the ground below, as the mammoth building program which will make Terminal City one of the most advanced air traffic centers in the country slowly takes shape. Developed in consultation with architect Wallace K. Harrison, the complex will eventually include a main arrival building flanked by wings housing foreign-flag airlines; individual terminals for major domestic lines; an operations building and a central heating plant — all connected by an intricate system of strikingly lighted roadways, and interspersed with parking lots and landscaped areas. At present, although the individual airline terminals in most cases are still a gleam in their planner's

eye, the rest of the development already hints at the scenic beauty which is expected to make this vast panorama of airport activity a major attraction for visitors to metropolitan New York.

Focal point for the 655 acre center is the International Arrival Building which, with its parabolic "gateway," adjacent wing buildings and nearby control tower, is now nearing completion. A U-shaped structure three stories high, the Arrival Building will handle all international air travelers. Outgoing passengers will check in at individual airline stations in the wing buildings, and proceed to their planes via the second floor of four double-decked arcades which provide enclosed passage to the 24 gate positions; incoming passengers will deplane, clear health, customs and im-



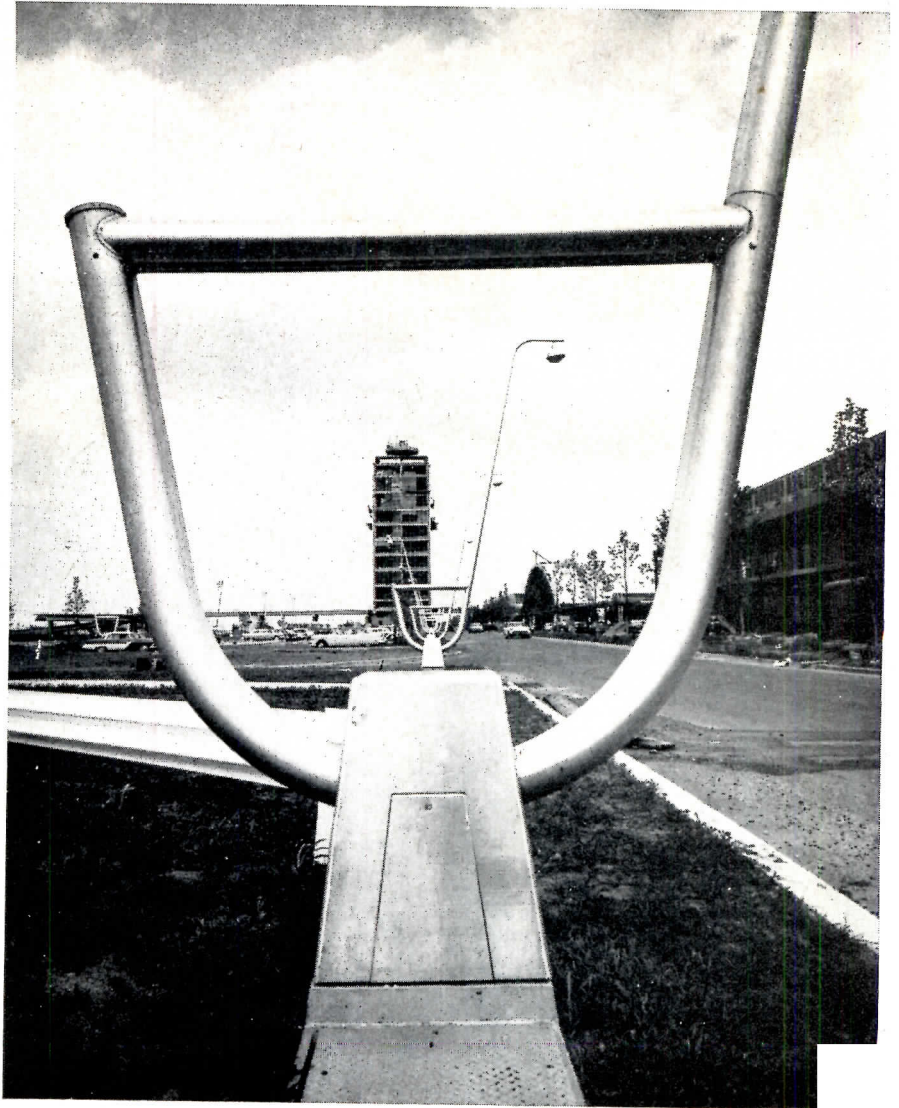
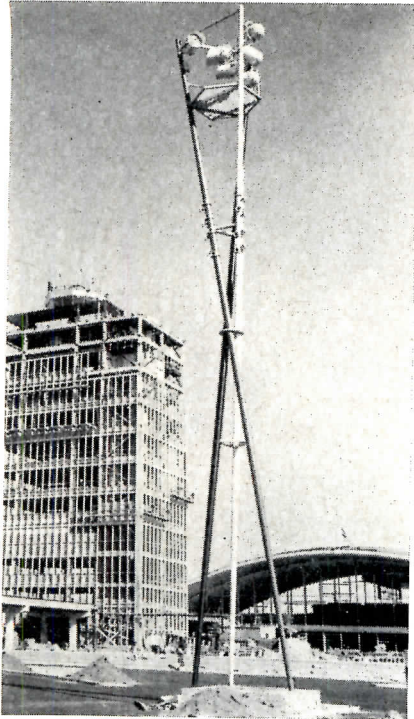

migration inspection services, and claim their baggage, all on the first floor.

To reach ground transportation, overseas travelers will go through a short passageway into an exit lobby which designer Charles E. Hughes of Skidmore, Owings and Merrill's New York office characterizes as a "gateway to the United States." This curved structure, whose parabolic arch economically encloses a wide sweep of column-free space, is in sharp contrast with the long (11 blocks), low lines of the Arrival and Airline Wing Buildings, and the verticality of the 11-story control tower. It is framed with two 6-ft-deep plate girders which form a three-hinged parabolic arch 230 ft across and 46 ft high at the mid-point. Light steel trusses serve as intermediate stiffeners, and the whole is

sheathed in stainless steel with standing seams following the curvature of the arch.

The steel framed Arrival and Wing Buildings are faced in a gray glazed brick, with panels of a bright yellow glazed brick relieving the expanse of glass along the front. The control tower, which will house electronic dispatching gear in addition to the control cab, is in aluminum and glass.

Fanning out in an oval from this "nerve center" are sites for the individual airline terminals — none of which are under way as yet. These will be linked with each other and with the arrival unit by a series of mutually related landscaped areas planned with the birds-eye view in mind. The roadways unwind concrete ribbons through colorful plant-

ing groups; huge reflecting pools mirror the sky; and lighting designer Abe H. Feder has thrown over the entire area "a blanket of never-ending daylight" that promises a nightscape as exciting as the daytime aspect of the giant complex. The roadways are lit by the graceful "lyres" shown above left; the parking lots and intervening spaces by 43 three-legged towers located on approximately 320-ft centers. Atop these 75-ft pylons are mounted 1500-watt mercury quartz vapor flood lamps in clusters of six, eight, ten or twelve. This system is flexible enough to provide uniform coverage in some areas, highlights in others, with the maintained level of illumination varying from 1.5 to 5 foot-candles. The brightness ratio is less than  $3\frac{1}{2}:1$ .

The indoor climate of the entire ter-



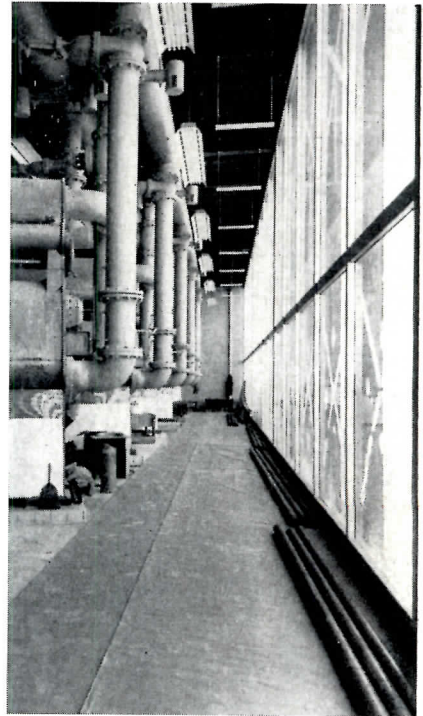
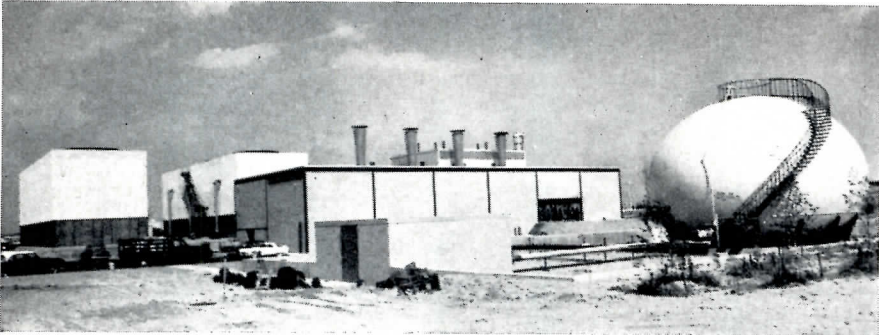
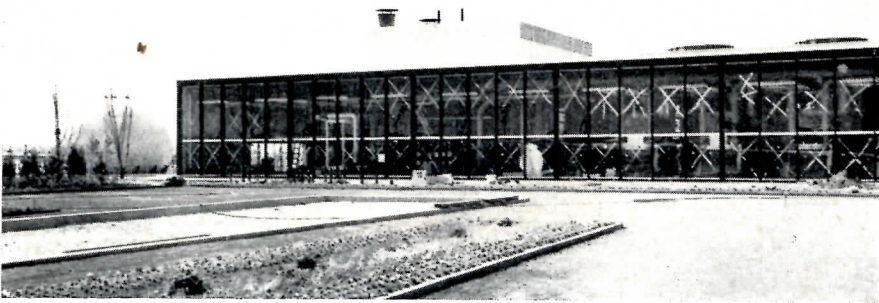

*The largest combined system of high temperature water heating and absorption cooling installed to date will carry hot water for heating and chilled water for cooling to campus-type passenger facilities at New York's Terminal City. Equipment is housed in the single-story steel and masonry structure shown above, its inner workings — and rainbow-painted service lines — bared to the public by a glass wall*

minal area will be controlled at a central heating and refrigeration plant from which a sprawling network involving some ten miles of pipe will feed hot water for heating and chilled water for cooling to the individual buildings — freeing them of such space-consuming and/or architecturally unattractive mechanical paraphernalia as boiler and equipment rooms, cooling towers and smokestacks. According to engineers Seelye, Stevenson, Value and Knecht, the system is the most extensive use to date of high temperature water for combined heating and absorption cooling. Capacity is 160,000,000 Btuh for heating and 7500 tons for cooling.

To house the primary equipment Skidmore, Owings and Merrill have designed an L-shaped showcase in which

light gray glazed brick and exposed black-painted steel form a muted setting for the colorful innards of the plant. Four generators, with auxiliaries and expansion drains, are housed in the wings; the nine absorption units march in double file behind a glass wall at the front of the building. Themselves a chaste white, the units are wrapped in a maze of brightly painted pipes whose colors reveal their contents — blue for condenser water, green for chilled water, red for hot water and orange for electrical conduit. Behind the building are two cooling towers framed in redwood and faced with transite siding, and the group is completed by a 5000 barrel capacity Horton (elliptical) spheroid tank opposite the boiler wing.

*(More Roundup on page 254)*



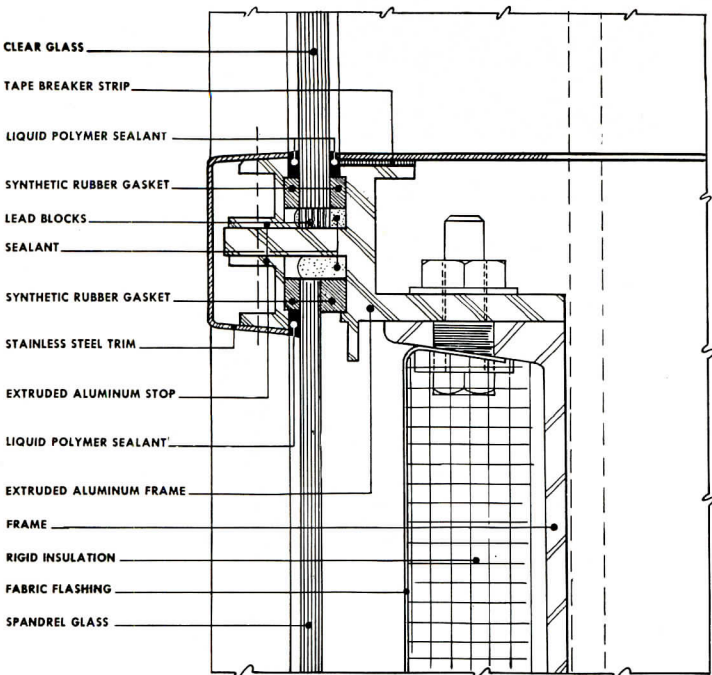

Glass Curtain Wall Sealing System (Section A)

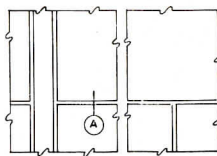

Key Elevation for Section "A" left

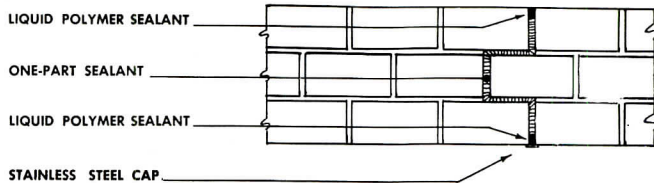

Expansion Joint in Brick Wall

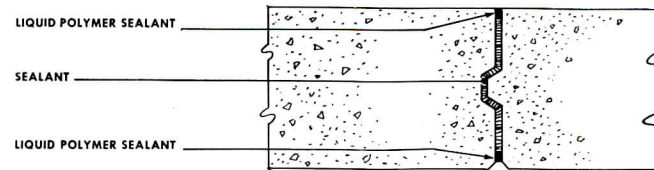

Expansion Joint in Concrete Wall

## New Glazing, Caulking Problems Call For New-Style Sealants

As curtain wall construction and oversized windows multiply the stresses placed on glazing and caulking compounds, the problems of protecting high-rise buildings against rain and weather approach those encountered in sealing aircraft—and the solution for the building field seems to lie in sealers borrowed from the aviation and marine industries.

Rubber compounds based on *Thiokol* liquid polymer, a polysulfide synthetic rubber, have been used as sealers and for caulking in aircraft and ships since 1945, and are now being used to meet the increasingly stringent sealing requirements of today's skyscrapers. When mixed with curing agents, the compounds cure at air temperatures to a rubber resilient enough to absorb strains

caused by normal expansion, contraction or vibration of a structure without cracking or allowing the entry of moisture, and adhesive enough to cling permanently to a wide variety of building materials—including glass, metal, wood and masonry. Unlike most rubbers, the *Thiokol* liquid polymer is not affected by exposure to oxygen or ozone, and resists attack by oils, solvents or corrosive atmospheres. Properly formulated compounds will develop the handling characteristics and properties listed in the table below, although any given compound may display some variation within this range of properties, depending on the specific ingredients employed in its manufacture. Differences in the compounds are usually determined by what a manufacturer feels to be the best

formulation for a particular type of application. For example, an expansion joint subject to heavy traffic would require a harder compound than would be used to seal a large expanse of glass where cushioning might be the major problem.

All of the *Thiokol*-based compounds come as two-part mixes—one package containing the liquid synthetic-rubber base with fillers and other additives, and the other containing the curing agent. Reinforcing agents and fillers (carbon black, whiting, aluminum powder, zinc sulfide and titanium oxide in varying proportions and combinations) thicken the polymer so that the mixed compounds can, in many cases, be applied to vertical surfaces without flow. Other additives are used to regulate curing and to obtain the desired adhesive properties. These ingredients, in viscous paste form, are combined on the job with the curing agent—usually lead dioxide suspended in a small amount of plasticizer. After the two components have been thoroughly mixed together, they can be applied with conventional caulking guns. Preparatory work will depend on the type of material to which a compound is being applied. A clean dry surface is required for all applications, and on concrete or masonry a primer should be used to secure proper bonding. *Thiokol Chemical Corp.*, 780 N. Clinton Ave., Trenton 7, N. J.

(More Products on page 274)

### Properties of Thiokol Liquid Polymer Compounds

Available colors	Buff, gray, black, aluminum, white
Set time at 80°F	Approximately 4 hours
Time to complete cure at 80°F	24 to 48 hours
Ultimate tensile strength	150 to 600 psi <sup>1</sup>
Elongation at break	200 to 500 psi <sup>1</sup>
Shore A hardness	20 to 60 <sup>1</sup>
Adhesion in shear	10 to 125 psi <sup>1</sup>
Adhesion in peel	20 to 40 lb per in. <sup>1</sup>
Water absorption	Less than 2 per cent <sup>2</sup>
Service temperature range	—65°F to 250°F

<sup>1</sup> Tests conducted on specimens cured for 24 hours at 80°F and tested according to standard (ASTM) rubber evaluation procedures.

<sup>2</sup> After four days' immersion at 80°F



RELATIVE AREA ENCLOSURE PROPERTIES OF PLANE SHAPES—1

By WILLIAM BLACKWELL

Geometry in architecture, sometimes boldly expressed and sometimes artfully concealed, is a part of the common core of knowledge and understanding which the architect uses to enclose space for human needs—one of his instruments, one of the tools, to be used in organizing and planning and decorating and integrating spaces so they can be built and understood and used. This study of some of the formal, basic series of geometric shapes which the architect uses, or may use, takes as its structure the unchanging relationship between the area and the perimeter of each shape.

Some shapes enclose an area with more or less perimeter than others, and this is a characteristic of the shape which can easily be expressed mathematically.

For example, the area enclosed by each unit of perimeter of a square is equal to the length of a side divided by four. The larger the square, the greater will be the area enclosed per unit of perimeter—the area/perimeter value. The same thing is true of a circle where the area enclosed per unit of circumference is equal to the diameter divided by four; and so the larger the circle, the greater will be the area/perimeter value. It is true also of any other shape that the larger it is the larger will be the area/perimeter value.

Because of this scale effect, because the area/perimeter value of all shapes changes with size in the same way, they have always the same relationship one to the other with respect to their area enclosure properties. For any given area then, the area/perimeter value of one shape can be expressed relative to the area/perimeter value of another shape.

Because a circle encloses a given area with less perimeter than any other closed shape, its area/perimeter value will always be greater—and so it is used here to express the relative area enclosure properties of other plane shapes. The area/perimeter value of a square, for instance, will always be 88.6 per cent of the area/perimeter value of a circle with the same area. This value is the area/perimeter factor, a comparison of the area enclosure properties of a square to those of a circle. Similar values can be found for other shapes, regular or irregular, by using the equation:

$$A_f = \frac{2\sqrt{\pi a}}{p} \times 100 \text{ or } \frac{354.5\sqrt{A}}{p}$$

Once the area/perimeter factor has been found for a shape, the process can be reversed and the area/perimeter factor used to find the actual area or perimeter of a shape if one or the other is known, providing a useful numerical relationship between the two similar to the 'k' and 'f' factors sometimes employed in handbooks to simplify calculations.

If the area is known, the perimeter can be found using the equation in this way:

$$p = \frac{2\sqrt{\pi A}}{A_f/100} \text{ or } \frac{354.5\sqrt{A}}{A_f}$$

If the perimeter is known, the area can be found by the equation:

$$A = \frac{1}{4\pi} \left[ \frac{A_f}{100} \times p \right]^2 \text{ or } .0796 \left[ \frac{A_f}{100} \times p \right]^2$$

For circles, squares or rectangles finding the area or perimeter isn't a very serious problem but in the case of many sided polygons, ellipses or irregular shapes, the area/perimeter factor can be useful.

The reciprocal of the area/perimeter factor can also be used to express the difference in the area enclosure properties of a shape and a circle. A square has a perimeter/area value of 1.128 (100/88.6) compared to a circle of 1, which is to say that a square has 12.8 per cent more perimeter than a circle with the same area.

It might be emphasized, too, that although

the area/perimeter factor is independent of "the scale effect" and is an unchanging factor regardless of the size of the shape, it is nonetheless an expression of the relative area enclosure properties of shapes for a given area. A large square might have an actual area/perimeter value twice that of a small circle. The usefulness of the factor lies then only in comparing the area enclosure properties of shapes for a given area.

The chart below illustrates the relative area enclosure properties of four related series of geometric shapes. They are arranged from bottom to top according to their area/perimeter factors, from 0 to 100 per cent, and from left to right according to the number of sides in the shape, from one to infinity.

In outline form and starting with the square are also shown some rectangles of different proportion to illustrate the change that occurs in the area enclosure properties of rectangles as the length-to-width ratio changes.

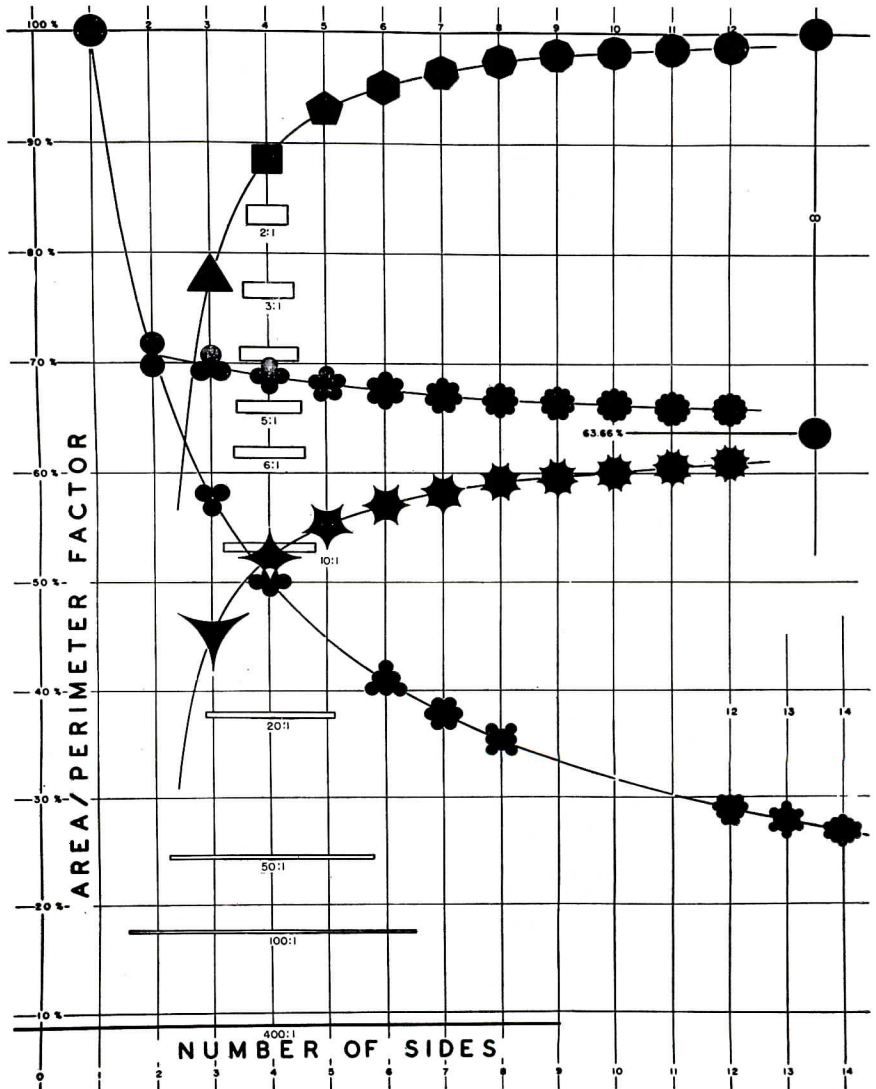





# STOP HER!

*...with acme*

Stop her to shop here... this is your store front design challenge. For store fronts that convert foot traffic to store traffic call on Acme Architectural Metal Molding. We'll help you put the STOP in STOPping Centers. Why not write or phone today?

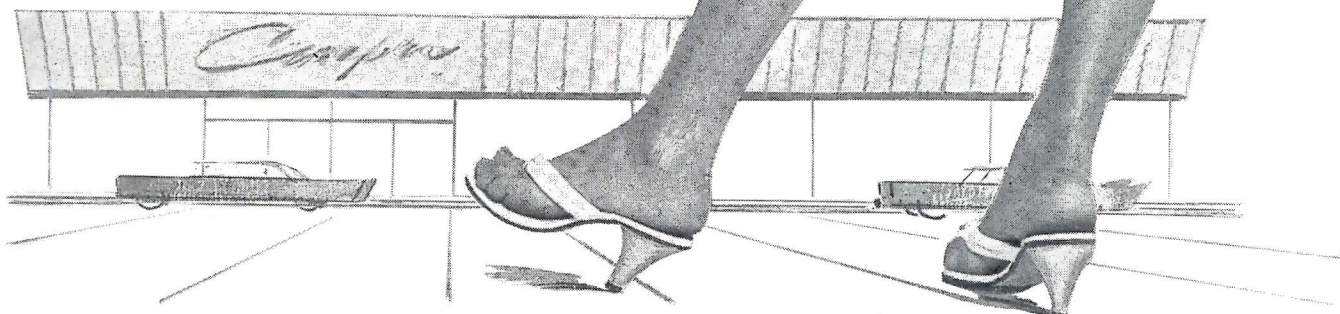

## STOPping centers designed with ACME:

SOUTH-BAY, REDONDO  
*Jones-Emmons-Gruen, Arch*  
 ORANGEFAIR, FULLERTON  
*Kooper-Maybach, Arch.*  
 EASTLAND, COVINA  
*A. C. Martin, Arch.*  
 WHITTIER BLVD. SHOPS, WHITTIER  
*F. A. DeNisco, Arch*

RIVERSIDE PLAZA, RIVERSIDE  
*V. Gruen, Plans—A. L. Jacobson, Arch.*  
 STONEWOOD, FULLERTON  
*Jacobson, Coppedge & Huxley, Arch*  
 IMPERIAL SQUARE, LONG BEACH  
*Carl Matson, Arch.*  
 COVINA CENTER, COVINA  
*Powers, Daly & DeRosa, Arch*



### OFFICES OF REPRESENTATIVES:

DENVER—5500 E. Quincy Ave., Englewood, Colorado, PLaza 5-0211  
 HAWAII—Lambert-Cole & Co., 685 Auahi St., Honolulu, Tel. 58456  
 MIAMI—Glass Product Inc., 224 Pan American Bldg., Miami 32, Florida, FRanklin 3-0347  
 NEW JERSEY—230 West Passaic Street, Maywood, New Jersey, HUbbard 9-6160  
 SAN FRANCISCO—1489 Burlingame Ave., Burlingame, Calif., DIamond 4-4577  
 CANADA—Acme Metal Moulding Co., Ltd., 416 West 2nd Ave., Vancouver 10, B.C., EMerald 2415

1923 SO. LOS ANGELES ST., LOS ANGELES 11, CALIF. RICHMOND 9-3331

Write for  
 our latest catalog

**acme**  
 metal molding  
 company

Since 1907



RELATIVE AREA ENCLOSURE PROPERTIES OF PLANE SHAPES—2

By WILLIAM BLACKWELL

The shapes on the chart all have the same area, so the difference in apparent size, as between one shape and another, can be seen.

**The Regular Polygons**

First of the four series of shapes shown in black on the chart is the regular straight-sided polygon series—the triangle, square, pentagon, etc. It begins, theoretically, with a straight line. Having two sides, a perimeter equal to twice its length but zero area, a straight line has an area/perimeter factor of 0 per cent. The first solid equilateral shape is the equilateral triangle (77.7 per cent), then a square (88.6 per cent), the five-sided pentagon (93 per cent) and so on—gradually approaching a circle (100 per cent) as the number of sides increases to infinity. Area/perimeter factors for some of the polygons in this series are given in the table below. The latter shapes in this series are extremely compact, with polygons of 13 sides or more having area/perimeter factors within 1 per cent of the area/perimeter factor of a circle.

In a limited sense, area/perimeter factors are a kind of efficiency factor, reflecting the degree of proximity of a shape to the area enclosure properties of a circle—as for instance, when a circular structure is divided into a number of straight sides for ease of fabrication.

**Concave-Convex Series:**

Under the regular polygons are two complementary series of shapes, now seldom used, but still familiar to architects as the shapes of brightly colored rose windows and vertically lined, fluted columns. These are the concave and convex aspects of the straight-sided polygons. Actually, which is which depends on whether the point of view is from the outside or the inside but the upper curve, the "rose" shapes, are taken to be the convex series and the lower curve, the "fluted" shapes, the concave.

Of the shapes in these two series, the most interesting is the three-sided concave shape formed by the interior arcs of three mutually

tangent circles. It might be called a "triarc." This shape has an area/perimeter factor of 45.2 per cent, the lowest of the regular geometric shapes. Although actually having the same area, it appears larger than any other shape on the chart. The circle and the "triarc" represent two extremes in area enclosure—the one with minimum and the other with maximum perimeter for a given area in a regular shape. Because of this difference (a 55 per cent difference in area/perimeter factors) and because of their opposite curvature, the two together form a very strong contrast in shape.

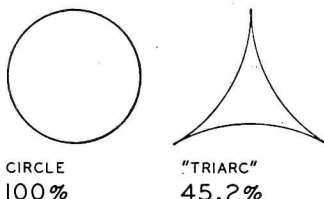

As the number of arcs in the circumference of both the concave and convex shapes increases, they converge on what appears to be a circle. Theoretically, it is a circle with its circumference made up of a very large number of very small arcs. With the area of each shape the same as it is on the chart, the arcs in the circumference become smaller as more are added. Finally, they are no longer apparent—the shape appears to be a circle. The actual circumference, greatly enlarged, would appear to be a line of semi-circles, like a series of arches, turned outward for the convex shapes, inward for the concave:



Because of the small arcs, the circumference is 1.57 times longer than the circumference would be without them. The area/perimeter factor of the shape then is 1.157 or 63.66 per cent.

**The Area/Perimeter Factor For Any Number of Separate Identical Shapes:**

Beginning with one circle at the upper left-hand corner of the chart is a curve showing the area/perimeter factor for various groups containing different numbers of circles. The groups shown were arrived at by starting with one, two or three circles at the center and proceeding outward, adding circles in the vacant pockets of each concentric ring. The same number of circles might, however, have been arranged in any other manner or even randomly placed and still have the same area/perimeter factor. Providing they all are of the same size, only the number of circles considered determines the area/perimeter factor.

The area/perimeter factor of any number of separate circles of the same size is equal to the area/perimeter factor of one circle (100 per cent) divided by the square root of the number of circles considered. And, it happens that this is true of other shapes: the area/perimeter factor of any number of separate, identical shapes taken as a whole is equal to the area/perimeter factor of one of the shapes divided by the square root of the number of shapes. One square has an area/perimeter factor of 88.6 per cent; nine squares, 29.5 per cent (88.6/3). A single leaf on a tree might have an area/perimeter factor of say 50 per cent, but if all the leaves are counted they would as a whole have an area/perimeter factor of very nearly zero.

The curve showing the area/perimeter factor for groups containing a different number of circles, then, illustrates what happens to the area/perimeter factor of any shape when it is divided into a number of separate identical shapes.

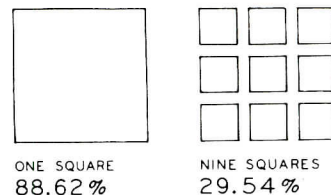

Instead of being arranged in their more compact form as they are on the chart, the same number of circles might have been arranged in a ring, adjacent to one another and equidistant from the center, as illustrated on page 251.

Lines between the centers (or the points of tangency) of adjacent circles form the regular straight-sided polygon series—the pentagon

**REGULAR POLYGON SERIES:**

No. of Sides	Area/Perimeter Factor	No. of Sides	Area/Perimeter Factor
3	77.756%	20	99.587
4	88.623	24	99.714
5	92.995	25	99.736
6	95.231	27	99.774
8	97.368	30	99.817
9	97.931	32	99.839
10	98.330	36	99.872
12	98.846	40	99.897
15	99.264	45	99.920
16	99.354	48	99.929
18	99.490	50	99.934



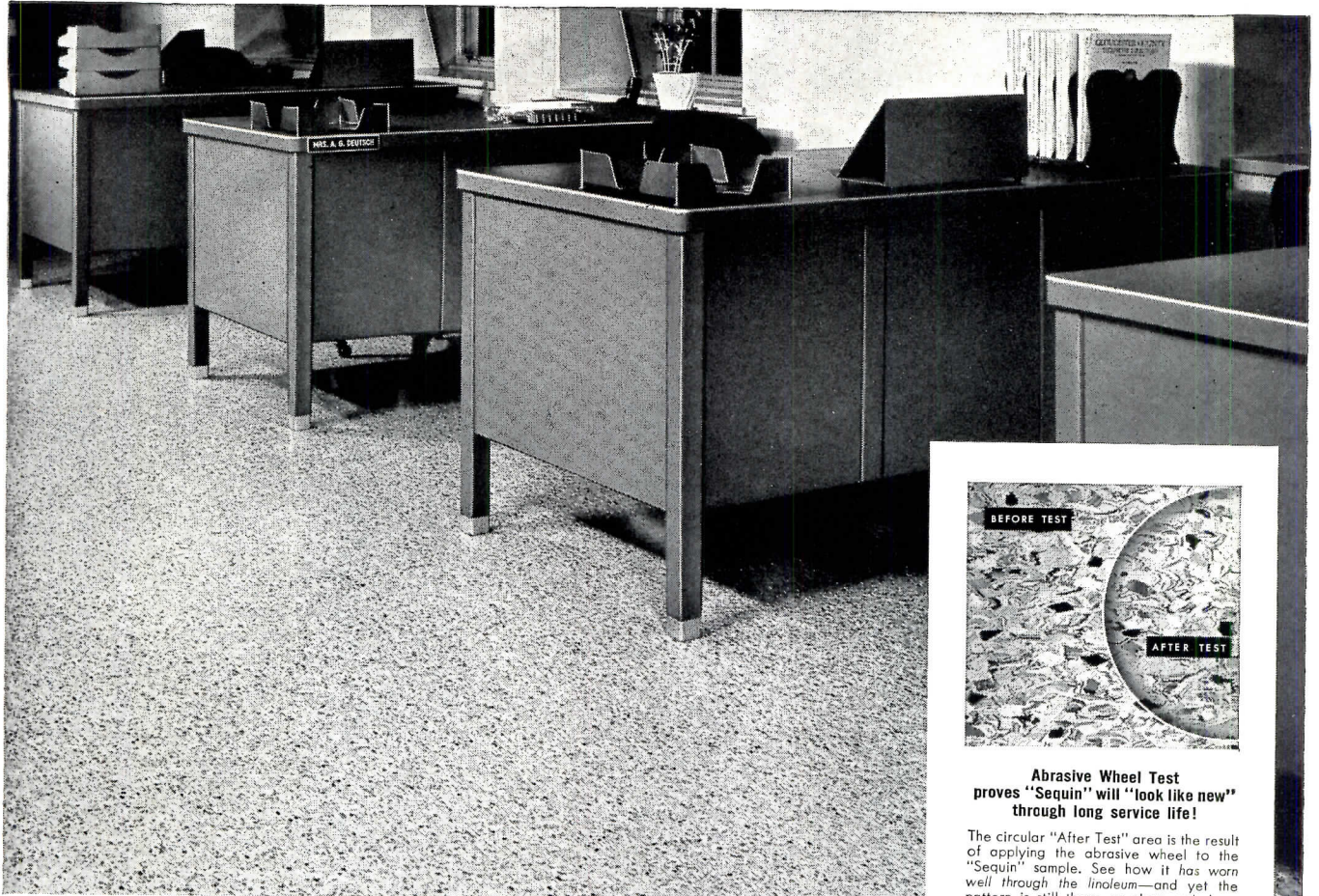

New Jersey Bell Telephone Company uses rugged "Sequin" in its busy new office in Glen Ridge. This beautiful floor provides quiet comfort underfoot and outstanding wear resistance.

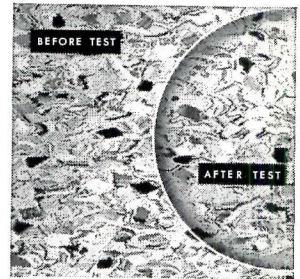

**Abrasive Wheel Test**  
proves "Sequin" will "look like new"  
through long service life!

The circular "After Test" area is the result of applying the abrasive wheel to the "Sequin" sample. See how it has worn well through the linoleum—and yet the pattern is still there, as clear and sharp as ever! Compare it with the "Before Test" area. You can't tell the difference! For information, write to Architects Service Dept., Congoleum-Nairn Inc., Kearny, N. J.

# Telephone Company uses *Gold Seal*<sup>®</sup> 1/8" Sequin<sup>®</sup> inlaid linoleum in its new office in Glen Ridge, N. J.

Any busy telephone office needs a long-wearing floor that's easy and inexpensive to maintain. New Jersey Bell Telephone Company has installed Gold Seal 1/8" "Sequin" Inlaid Linoleum.

"Sequin" gives your busiest industrial or institutional clients modern, textured floor beauty plus the traditionally low maintenance of Gold Seal Inlaid Linoleum. Stains, grease, grime wipe easily away. And tough, resilient "Sequin" provides quiet comfort underfoot... resists indentation... defies years of punishing traffic.

In addition to "Sequin," Gold Seal offers you a whole family of inlaid linoleum and resilient tile flooring materials—each with its own special uses and advantages. All are designed to please the most exacting client.

**SPECIFICATIONS**—1/8" "Sequin" linoleum 6' wide yard goods, 9" x 9" tile 1/8" gauge, burlap-backed. Install over suspended wood or suspended concrete subfloors (even over radiant heat). Available in: grey, green, dark brown, white multi, grey mix, taupe, beige and white with black. Also made in standard gauge for residential use—in 18 colors.



**FOR HOME / BUSINESS / INSTITUTIONS:**

BY THE YARD AND TILES—Inlaid Linoleum • Nairn<sup>®</sup> Plastics • Vinylbest<sup>®</sup> Tile • Cork Tile • Rubber Tile • Asphalt Tile • PRINTED FLOOR AND WALL COVERINGS—Congoleum<sup>®</sup> and Congowall<sup>®</sup> • RUGS AND BROADLOOM—LoomWeave<sup>®</sup> • \*Trademark • Satisfaction guaranteed or your money back • © 1957 CONGOLEUM-NAIRN INC., KEARNY, N. J.





## RELATIVE AREA ENCLOSURE PROPERTIES OF PLANE SHAPES—3

By WILLIAM BLACKWELL

in the illustration. The exterior perimeter of the whole form is the convex aspect of the polygon and the interior perimeter of the circles the concave. The circles themselves, the regular polygon and its concave and convex aspects make up the four series of shapes shown in black on the chart.

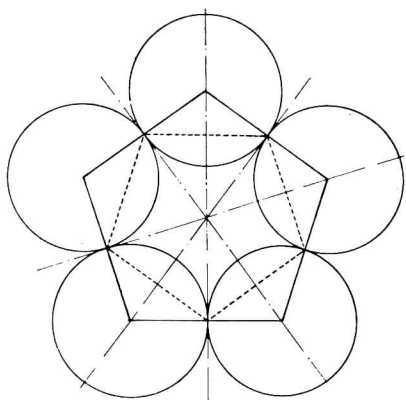

### Rectangles:

In outline form, and starting with the square in the regular polygon series are some rectangles, the shapes most frequently used by architects because of the ease with which they accommodate most needs for enclosed space. The area/perimeter factor of a rectangle is determined simply by the length-to-width ratio, the proportion. A square (1:1) has the highest factor, 88.6 per cent, and the farther the rectangle deviates from the square in proportion, the lower will be its area/perimeter factor. As the length becomes very great with respect to the width, the "width" disappears, leaving a straight line with an area/perimeter factor of 0 per cent. It is possible then for a rectangle, depending on its proportion, to have any area/perimeter factor from 0 to 88.6 per cent.

The greatest difference in the area/perimeter factors of two closed shapes is, of course, 100 per cent—reached between a straight line and a circle and approached between a circle and a very long rectangle. There is one example of this contrast, used architecturally to a softer degree, in the chapel Saarinen designed for M.I.T. Here one enters the dimly-lighted, circular brick chapel through a lightly enclosed rectangular passageway. Between the high area/perimeter factor of the circle and the lower factor of the rectangular entry, there is a difference of about 25 per cent. Looking at the chart and the range of shapes normally used architecturally, this is a very considerable difference.

Room shapes, for instance, are normally nearly square in plan, with length-to-width ratios from 1:1 to about 1½:1; seldom greater than 2:1. The difference in the area/perimeter

factor of a square room and one with a relatively high length-to-width ratio of 2:1 is only about 5 per cent.

Building shapes, especially low buildings, cover virtually the whole range of rectangles, from squares to the mile-long production line enclosures of the Second World War. "L" and "T" and other arrangements are equivalent to relatively long rectangles. Because they have lower area/perimeter factors (more perimeter) they have also a higher degree of light and openness and flexibility in the arrangement and rearrangement of the internal spaces than the more compact shapes.

On the other hand, economy of exterior perimeter is an important consideration in almost every building, too, because of material and labor saving, maintenance costs, and reduction in heating and cooling loads. It is particularly important in multistory buildings where the outside wall surface is very large compared to the roof area. These buildings tend to have more compact shapes, with the perimeter reduced just to the point where if it were reduced further the spaces within would be adversely affected. To give one example, the glass-enclosed rectangles of Lever House have a length-to-width ratio of about 3:1 and an area/perimeter factor of 77.5 per cent. A square plan (88.6 per cent) might have been more economical in terms of the perimeter but would not have the same degree of light and openness and planning flexibility (and interest, too) that the rectangular shape has with some additional perimeter.

As a matter of interest, the "golden section" (1.62:1) has an area/perimeter factor of 86.12 per cent, 2½ per cent less than a square. The area/perimeter factor for other rectangles can be found by using the equation

$$A_f = \frac{\sqrt{\pi l/w}}{1 + l/w} \times 100$$

or taken directly from the curve below.

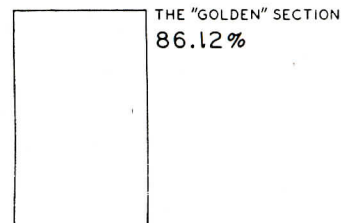

### Ellipses:

On the same graph with the rectangle curve is another curve showing the area/perimeter factor for ellipses of different proportion. In the same manner as the rectangles, ellipses have lower and lower area/perimeter factors the further they deviate from a circle in proportion. It happens that for proportions less than about 5.75:1 ellipses have higher area/perimeter factors than rectangles of the same proportion but for proportions greater than 5.75:1 rectangles have the higher factors. With a length-to-width ratio of 5.75:1, both have an area/perimeter factor of 62.98 per cent.

When the major and minor axis of an ellipse are known, the area can be found using the equation,  $\pi ab$ . The circumference can then be found by taking the approximate area/perimeter factor from the curve and using the basic equation:

$$p = \frac{2\sqrt{\pi A}}{A_f/100}$$

This will be as accurate as the area/perimeter factor can be read from the curve, plotted from tabulated values of elliptic integrals.

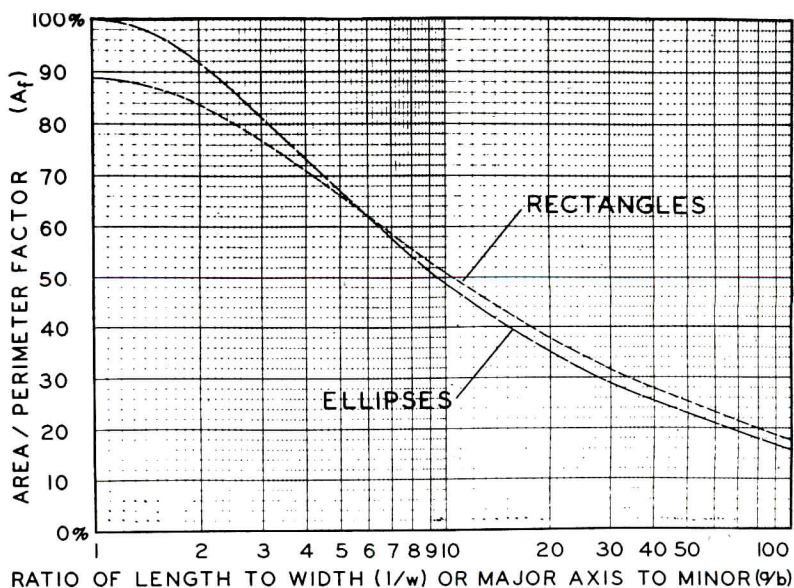





These mechanics are installing an Armstrong Minatone Ceiling under ideal job conditions. Electrical work has been located, and the building is thoroughly dry.

## How to determine when to

Selecting the right time to install acoustical ceilings may often mean the difference between an attractive or an unattractive finished job.

Frequently, the acoustical contractor is ordered to go ahead with the ceiling installation just after masonry work has been completed or even while the building is still partially open. Under these conditions, mineral or fiber composition tile that is exposed to excessively humid conditions absorbs some moisture and may expand. When air conditioning or heating is turned on to make the building ready for occupancy, a great deal of the moisture is removed from the interior. This change in humidity conditions may cause tiles to contract and result in an unsatisfactory appearance.

The Acoustical Materials Association considers acoustical ceilings to be in the same category as other fine interior finish materials. They recommend that the ceilings be installed under the same interior conditions that will exist when the building is occupied.

According to the Acoustical Materials Association, the best time to install acoustical ceilings is after the building is fully enclosed and the heating or air-conditioning system has been in operation for at least one month. All "wet operations" such as plastering, concrete, and terrazzo work should be complete and dry. Windows and doors should be in and glazed. If the acoustical ceiling is suspended from floor slabs or roof deck, the space between the deck or slab and the ceiling should be vented to the outside. And, for



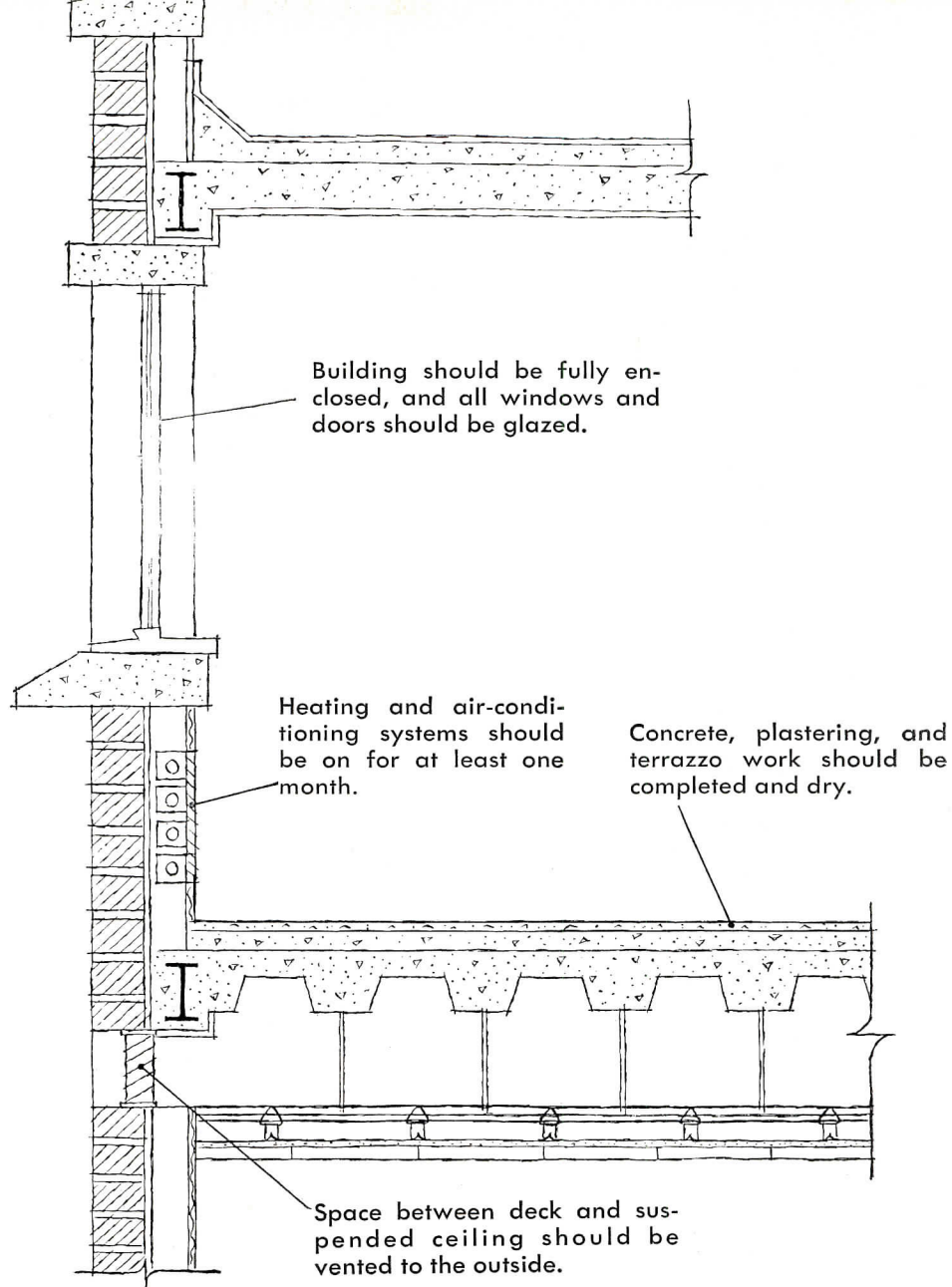
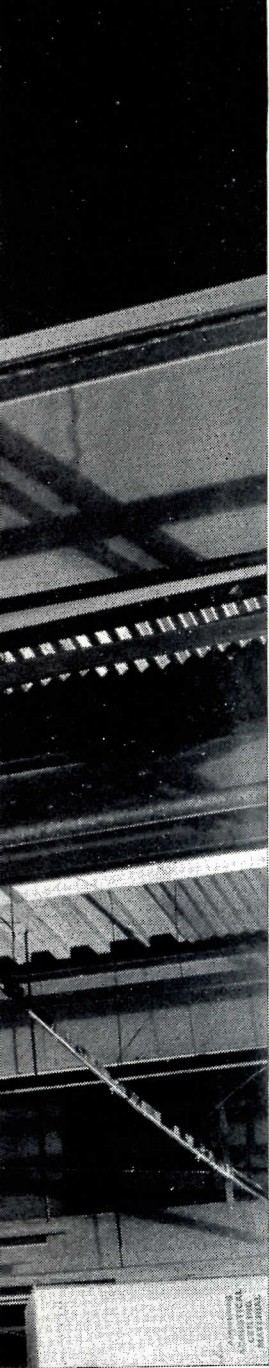

## begin acoustical installation

best results, acoustical materials should be delivered to the job just prior to installation.

To assure the most satisfactory results from the standpoint of appearance and acoustical efficiency, most architects insist that acoustical ceiling installations rigidly comply with these basic job conditions.

For detailed information on recommended installation procedures or data on any of the complete line of Armstrong Acoustical Ceilings, see your Armstrong Acoustical Contractor. He'll be glad to assist you with any ceiling problem. You'll find him listed in the Yellow Pages of your phone directory.

For a free, illustrated booklet on the latest sound-conditioning methods and materials, write to Armstrong Cork Company, 4209 Rock St., Lancaster, Pa.

**Armstrong**

**ACOUSTICAL CEILINGS**

Cushiontone® • Travertone\* • Arrestone®

Minatone® • Corkoustic® • Crestone®

\*TRADE-MARK



(Continued from page 243)

**CEMENT COMPANY'S OFFICE  
DISPLAYS CONCRETE WARES**

Disproving the old adage about the ill-shod condition of the shoemaker's children, the Medusa Portland Cement Company has put its recently completed National Headquarters Building in Cleveland Heights, Ohio, to work as a showcase for architectural concrete.

Curved to follow the contour of the boulevard on which it fronts, the two story structure designed by architect Ernest Payer consists primarily of two office wings flanking a central lobby which extends the full height of the building. Executive offices are housed in a roof-level penthouse, and a one-story basement annex completes the plan.

To make the curved shape possible without adding appreciably to the cost, the building was constructed by the lift slab method, with the 10 in. flat plates for the second floor and roof hoisted around columns made up of 8 in. angles welded to form box sections. The roof slabs cantilevered over the column-free lobby were later filled in with poured-in-place strips, and beams were up-set to carry the extra weight of the penthouse.

The use of concrete is more evident in an exterior curtain wall composed of double precast panels with a foam glass core sandwiched between an inner layer of white cement and an outer layer of concrete with a green aggregate. The panels, which are suspended vertically from the cantilevered slabs by heavy steel angle connections, are given wind stability by their final connection to the structural aluminum grid that completes the exterior wall construction. Two stories high and two panels wide, the grid sections are prefabricated with heads and sills shop welded. End walls of the building are of bevel-edged three inch solid concrete panels with an exposed white marble aggregate, while

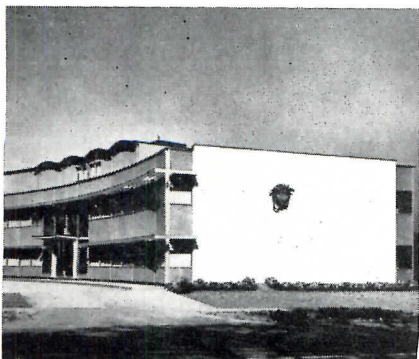

(More Roundup on page 258)

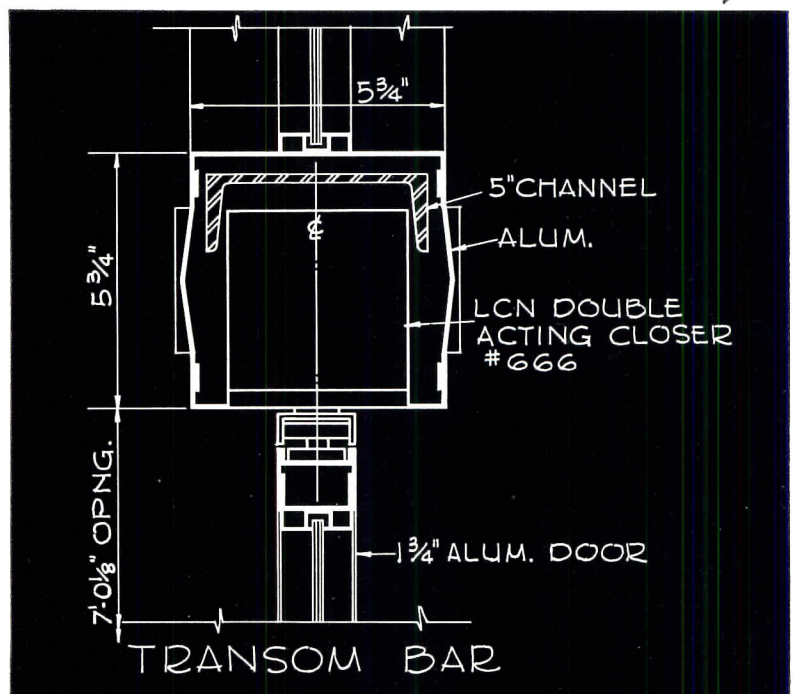
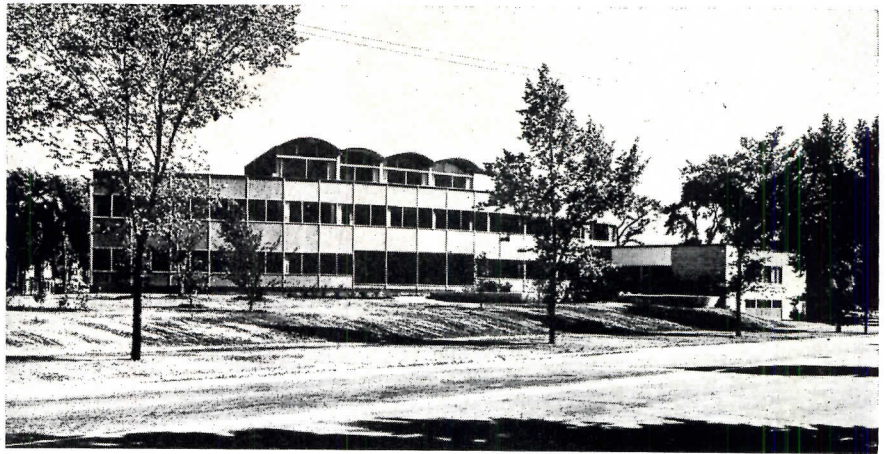

**CONSTRUCTION DETAILS**

for LCN Overhead Concealed Door Closer Shown on Opposite Page

*The LCN Series 644-666 Closer's Main Points:*

1. Flap-free control for double-acting doors
2. Handles exterior doors of normal height up to 3'6" wide; interior doors to 4'0"
3. Power applied by a lever arm; in-swing and out-swing are adjustable separately
4. Used for wood, metal or tempered glass doors having top members 1 3/4" thick or more
5. Pivots included. Hydraulic back-check. No special threshold needed.

*Complete Catalog on Request—No Obligation  
or See Sweet's 1957, Sec. 18e/La*

**LCN CLOSERS, INC., PRINCETON, ILLINOIS**

Canada: Lift Lock Hardware Industries, Ltd., Peterborough, Ontario



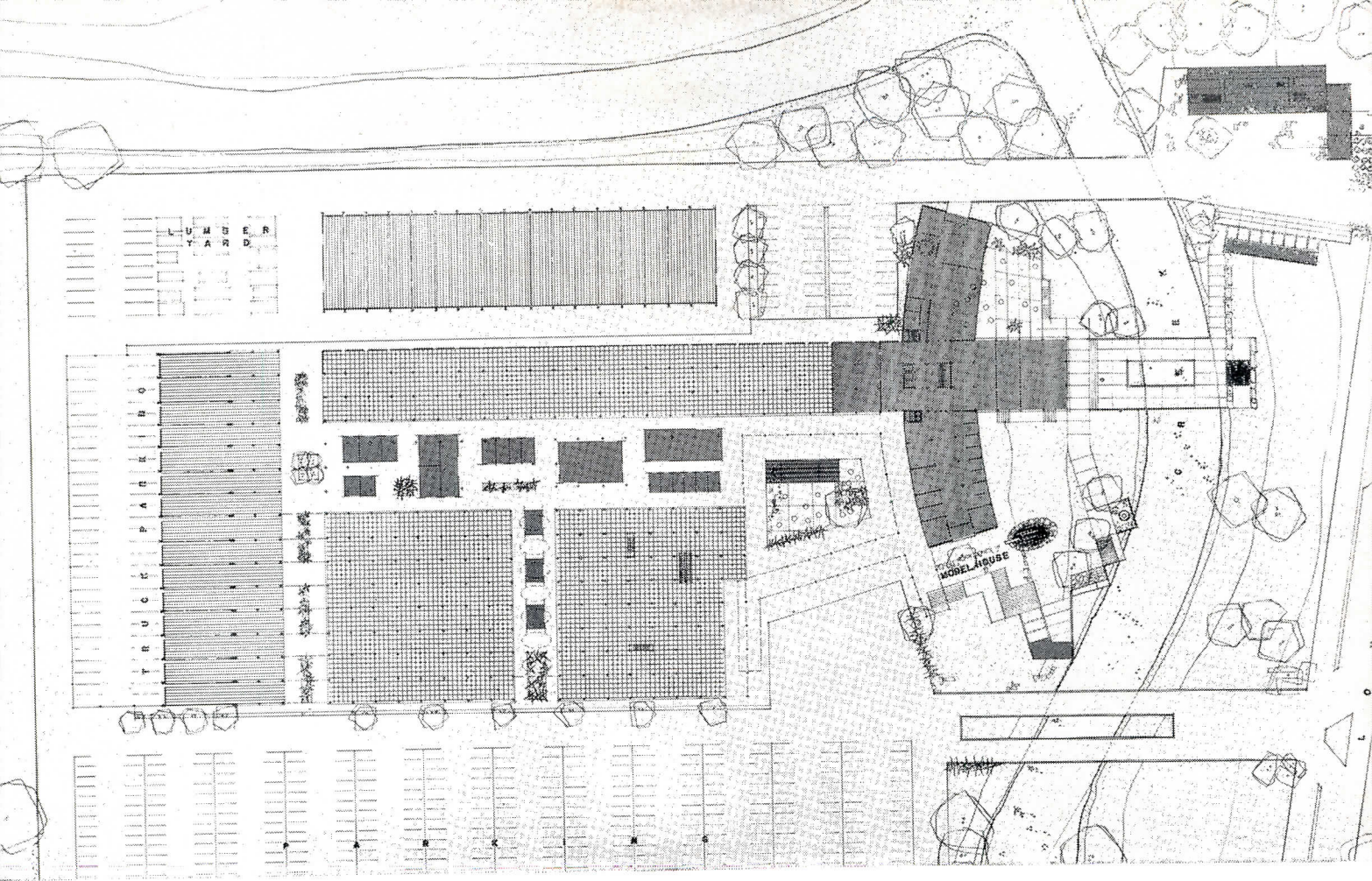

Arthur Bohnen, Developer, Chicago

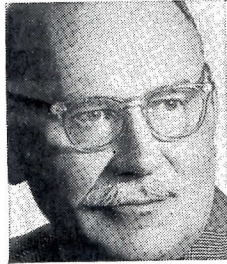

# center

by Arthur Bohnen

Because such a project provides so many interesting design and product application opportunities, Carey commissioned Mr. Stuermer to adapt some of his original design ideas to show how Carey Building Products could be used in constructing a shopping-center for homes.

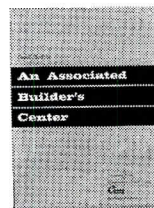

Architect Ray Stuermer's plan and detail sheets are available to architects and builders. Ask your Carey representative or write The Philip Carey Mfg. Company, Lockland, Cincinnati 15, Ohio, Dept. AR-97.

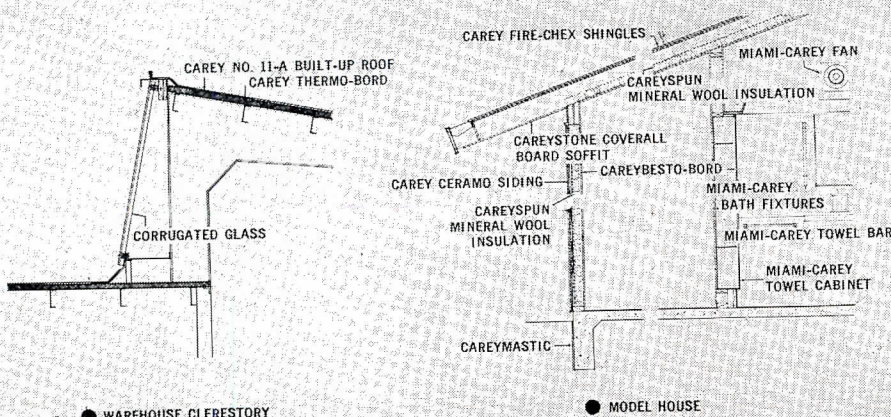

# Carey<sup>®</sup>



BETTER PRODUCTS FOR BUILDING SINCE 1873



# BOOM FORECAST in RESIDENTIAL AIR CONDITIONING

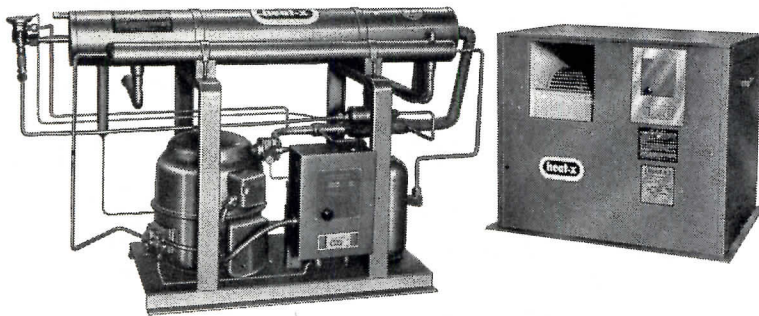

Assure YOUR Profit Share  
with these NEW **heat-x** Units

Completely packaged water chillers... in 2, 3 and 5 HP models... designed for easy, speedy installation that *builds profits*. Available in water-cooled models ('RPC') and air-cooled models ('ARPC'), these new Heat-X units were developed *specifically* for residential and light commercial air conditioning systems.

High efficiency patented Inner-Fin® construction of chillers, superheaters and condensers makes these the most compact units on the market. All water passages are of non-ferrous construction, eliminating corrosion problems.

Don't be left behind in the coming residential air conditioning boom. Write today for complete data on 'RPC' and 'ARPC' units.

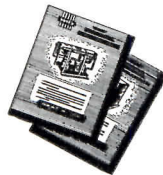

## HEAT-X, Inc.

A Subsidiary of Dunham-Bush, Inc.

BREWSTER • NEW YORK

### TECHNICAL ROUNDUP

(Continued from page 254)

the one story annex is made of split rock units and large (up to 17 ft long) concrete panels.

Because of the building's curvature, the four 3½ in. thick, multiple span barrel thin shells that form the roof of the penthouse vary in length from 29 to 37 ft and have spans ranging from 12 ft-3 in. to 5 ft-6 in. Their axes, which diverge to match the radial lines of the building, are tipped so that the tops of the shells are higher at one end than at the other. At the front of the building, their horizontal thrust is taken by poured concrete ribs, integral with the shells, but dropped down to act as stiffeners or fins. At the rear, it is taken by shallow up-set concrete arches.

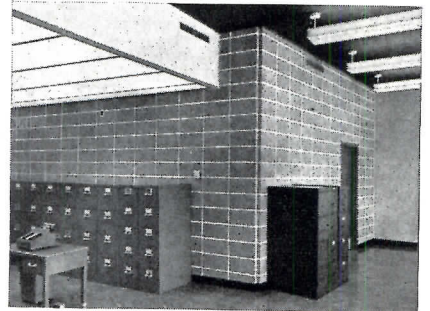

The extensive use of concrete on the exterior is matched on the interior, where walls of colored concrete block are supplemented by precast panels of various kinds, including the sculptured panels used on the lobby wall shown. The open staircase leading to the second floor balcony is also of concrete, with solid terrazzo treads cantilevering from both sides of a single precast stringer.

#### ADDENDUM

In the discussion of the steel frame foundation used for the Paul F. Watson residence in Fort Worth, Texas (ARCHITECTURAL RECORD, February 1957, p. 266), credit was omitted to architect-engineer Morris B. Parker, who designed both the house itself and the underlying foundation system.

(More Roundup on page 262)



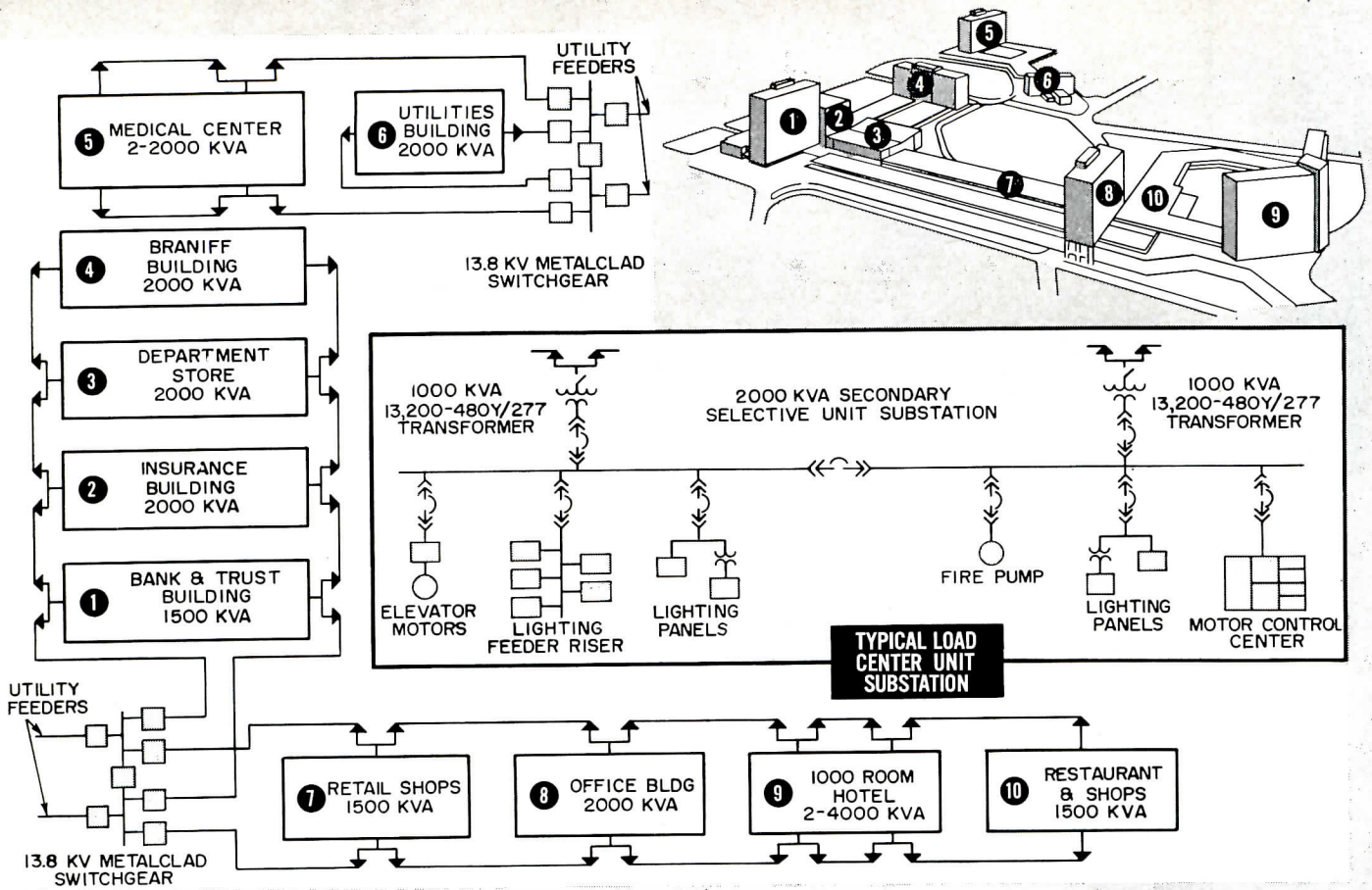

FLEXIBLE, ECONOMICAL POWER distribution system for entire Park Project is contained in one-line diagram. Numbers

key equipment to Project buildings. Completed Utility Building also uses General Electric 480Y/277-volt equipment.

## serves power needs of "city within a city"

\$125 million Exchange Park Project in Dallas shows how General Electric's "system approach" is key to flexible, economical commercial power distribution.

To keep pace with the Southwest's vigorous economic growth, a \$125 million commercial center is rising on 120 acres four miles from downtown Dallas. Known as Exchange Park, this community represents one of the most advanced city-within-a-city developments yet attempted in the United States. It is scheduled for 1960 completion. Nine major buildings, parking for 15,000 cars, 40-foot-wide air conditioned malls, 150 retail shops, and other facilities will enable shoppers to take care of every personal and business need in scientific comfort. Already completed: Exchange Bank and Utility Building.

**SELECTING THE BEST POWER DISTRIBUTION SYSTEM**, to satisfy Exchange Park's heavy load concentration efficiently and economically, required thorough system analysis early in project planning. G-E engineers, working closely with Mr. George M. Bostock, Vice-president and Engineering Manager of Exchange Park and his consultants\*, recommended a 480Y/277-volt

secondary selective system as optimum. General Electric also provided basic system layout, service engineering and installation assistance at the site.

**ADDED VALUES** stem from adoption of G-E system recommendations. Exchange Park's 13.2 kv distribution system has capacity for load growth. Secondary selective system features permit reliable operation. Utilization of 480Y/277-volt system means fewer, less-metal circuits and substantial dollar savings. Using 480Y/277-volt equipment in only two of nine buildings, for example, saved \$90,000.

**GENERAL ELECTRIC SYSTEM ENGINEERING CAN HELP YOU** on your construction project. Call on G-E engineers early in your planning when they can be of greatest value. Contact your nearest G-E Apparatus Sales Office or write General Electric Co., Section 680-12, Schenectady 5, N. Y.

\*Architect: Lane, Gamble and Associates

Consultants: Blum and Guerrero

Electrical Contractors: Fischbach and Moore; Superior Electric Co.

Engineered Electrical Systems for Commercial Buildings

**GENERAL**  **ELECTRIC**



# Executone gives you **4-way service** for sound and intercom systems!

We provide not only wiring plans, shop drawings, specifications and costs, but with our nation-wide organization of exclusive distributors we also give your clients on-premise maintenance of equipment and instruct their personnel in its proper use. If you have a job on your boards that should utilize intercom or sound, you should be familiar with these four important Executone services:

## Not only this...

**1 Consultation Service**

Executone's Field Engineers will assist you in determining your clients' communication needs... recommend the system designed for the job... provide you with a professional consultation service.



**2 Installation and Supervision**

Each local Executone distributor is prepared to take full responsibility for the final and satisfactory operation of the system, whether installed by the contractor, or his own factory-trained crew.

## But also this!

**3 On-Premise Maintenance**

Each local distributor is staffed with skilled, factory-trained technicians. They also have complete stocks of standard replacement parts. Continuous, uninterrupted performance of every Executone system is assured.



**4 Personnel Instruction**

Local Executone representatives instruct your clients' personnel in the proper use of Executone Systems. This planned program assures maximum benefits through proper operation and utilization of their systems.

Architects and engineers are invited to send for Executone's 325 page Reference Manual "B-6." No charge or obligation. Please use your letterhead.

# Executone

INTERCOM AND SOUND SYSTEMS FOR  
HOSPITALS, SCHOOLS, HOMES, PLANTS, OFFICES

415 Lexington Ave., New York 17, N.Y. • In Canada... 331 Bartlett Ave., Toronto



## TECHNICAL ROUNDUP

### EXPOSED SEMI-ELLIPTICAL ARCHES FRAME ARIZONA GYM



Four semi-elliptical welded steel arch beams project above an integral roof-ceiling of prefabricated steel building panels to give a distinctive "inside-out" appearance to the main arena for a gymnasium in Willcox, Arizona.

Shop-fabricated in three sections and butt-welded together in the field, the arches are spaced on 22 ft centers, with masonry walls replacing the beams at the ends of the building. The arch webs taper gradually from the base to top center; the 10 in. wide lower flanges support the 6 in. thick building panels that are welded to them. Because the beams are designed so that compression stresses lie along the lower flanges, these light gage panels are used as lateral bracing, in addition to serving as both the structural roof and the finished ceiling. The corrugated paneling on the interior provides built-in acoustical treatment. On the exterior, the panels are faced with  $2\frac{5}{32}$  in. rigid insulation, over which is laid a terne sheet metal roof with raised seams paralleling the arches. Where the arches project through, a continuous metal flashing strip about 6 in. wide is wedged into place on both sides of the beam, and its upper edges capped by 2 in. wide steel reglets welded to the web beam.

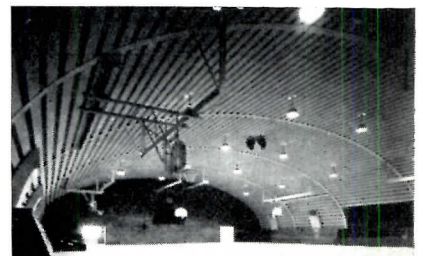

Designed by Scholer, Sakellar & Fuller of Tucson, Arizona, the structure accommodates two basketball courts which extend across the width of its completely unobstructed interior. A 25 by 85 ft single story structure housing locker rooms and service facilities runs along one side of the main arena; in front is a small entrance building flanked by curving porticoes.

(More Roundup on page 266)



# w<sup>th</sup> LUPTON metal windows

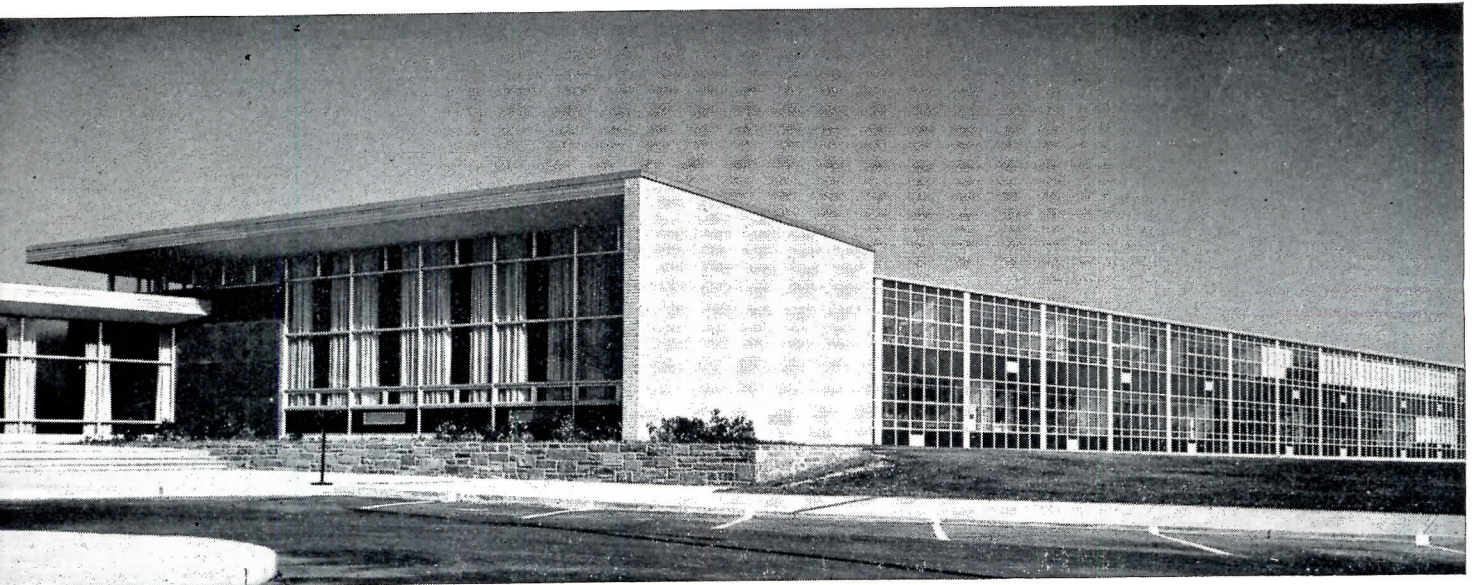

Penncrest Senior High School, Lima, Pa. Architects & Engineers: The Ballinger Co., Philadelphia, Pa.; General Contractors: Wallace Engineering & Construction Co., Bryn Mawr, Pa. All photographs by Cortlandt V. D. Hubbard.

## New Penncrest Senior High School at Lima, Pennsylvania, matches bold design with maximum light and air

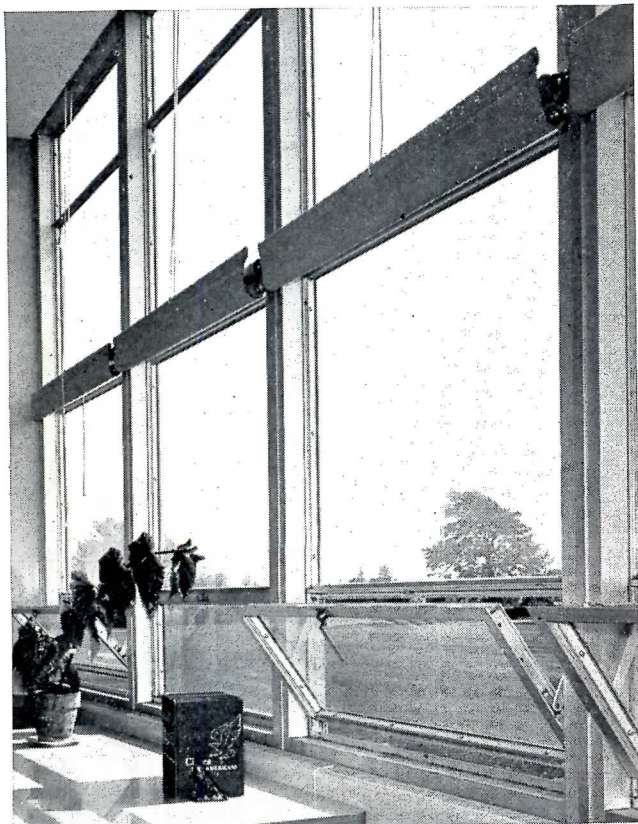

LUPTON Master Projected Aluminum Windows provide all-weather ventilation, deflect drafts, and provide various degrees of opening. Simplicity of hardware makes them easy to use, inexpensive to maintain.

A brilliant illustration of the harmony of fresh and forceful design with functional need is shown in the modern Penncrest Senior High School at Lima, Pennsylvania.

The use of LUPTON Master Projected Aluminum Windows helped make this "dream school" a practical reality. The strong horizontal lines and narrow mullions of these windows integrate exactly with the design intention. Their unobstructed areas, all-weather ventilation, lower initial cost, and lower maintenance costs make them a perfect choice for practical function.

For more than 75 years, LUPTON has been providing the finest metal windows to the country's leading architects for use in schools, hospitals, and other modern buildings. You'll find complete information in the Flynn catalogs in Sweet's *Architectural File*. To locate your nearest representative, look for the name LUPTON in the Yellow Pages under "Windows—Metal." Or write or wire.

# LUPTON

**METAL WINDOWS • CURTAIN WALLS**

MICHAEL FLYNN MANUFACTURING COMPANY

MAIN OFFICE AND PLANT: 700 E. GODFREY AVE., PHILA. 24, PA.





... AND  
2-YEAR EXPOSURE  
TESTS PROVE IT!

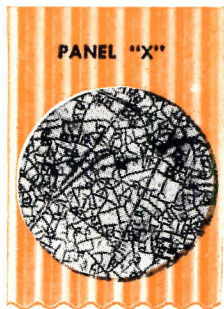

STRUCTOGLAS "A" . . . molded from a new extra-hard resin\* . . . is the first reinforced plastic panel to offer proven resistance to weathering and discoloration. As shown in the above photomicrographs, STRUCTOGLAS "A" was virtually unchanged in surface gloss or color after 2-year outdoor exposure. In the same tests, PANEL "X" (like other competitive panels made from good light-stabilized resins) lost all gloss and "alligatorred" so badly the glass fibers were exposed, which greatly reduced its ability to transmit light.

These results prove only STRUCTOGLAS "A" assures prolonged weather resistance, lasting beauty and consistent light transmission . . . at competitive prices!

\*A product of Rohm & Haas Co.

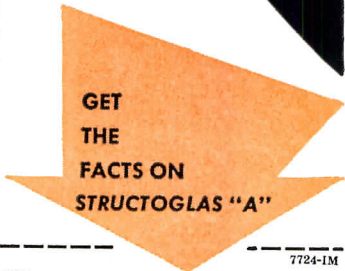

**structoglas**®

division of

international molded plastics, inc.

4390 West 35th Street • Cleveland 9, Ohio

Gentlemen:  
Please send me free, a complete Structoglas Data File.

NAME \_\_\_\_\_ TITLE \_\_\_\_\_

COMPANY \_\_\_\_\_

STREET \_\_\_\_\_

CITY \_\_\_\_\_ ZONE \_\_\_\_\_ STATE \_\_\_\_\_

7724-1M

TECHNICAL ROUNDUP

CRYSTALLINE GLASS: A NEW ARCHITECTURAL MATERIAL

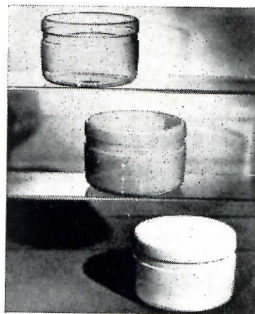

A new family of crystalline materials made from glass exhibit unique characteristics that point to their potentially wide application in the building field, and particularly in curtain wall construction. Developed under the direction of Dr. S. Donald Stookey, manager of Corning Glass Works' Fundamental Chemical Research Department, the tough heat-resistant substances can be made-to-order with a wide range of controlled properties — including types that are harder than steel, lighter than aluminum and nine times as strong as plate glass.

The material is made by adding special nucleating agents to glass, cooling it to solid form, and putting it through a heat-treating process during which it is transformed into a flint-hard, fine-grained crystalline substance more akin to ceramic than to glass. In final form, it can be chalky white, translucent, or transparent with a faint brownish cast reminiscent of tinted plate glass.

Because they remain glass until after they have been formed into objects and heat-treated, the *Pyrocerams* can be worked by such conventional glass-manufacturing processes as blowing, pressing, drawing or spinning. Some of them are fluid enough in the glassy state to lend themselves also to the centrifugal and investment casting techniques usually used in working metals.

Although the *Pyrocerams* are still a long way from the commercial market, Corning predicts that the material will cost only slightly more than glass, and far less than stainless steel.

(More Roundup on page 270)



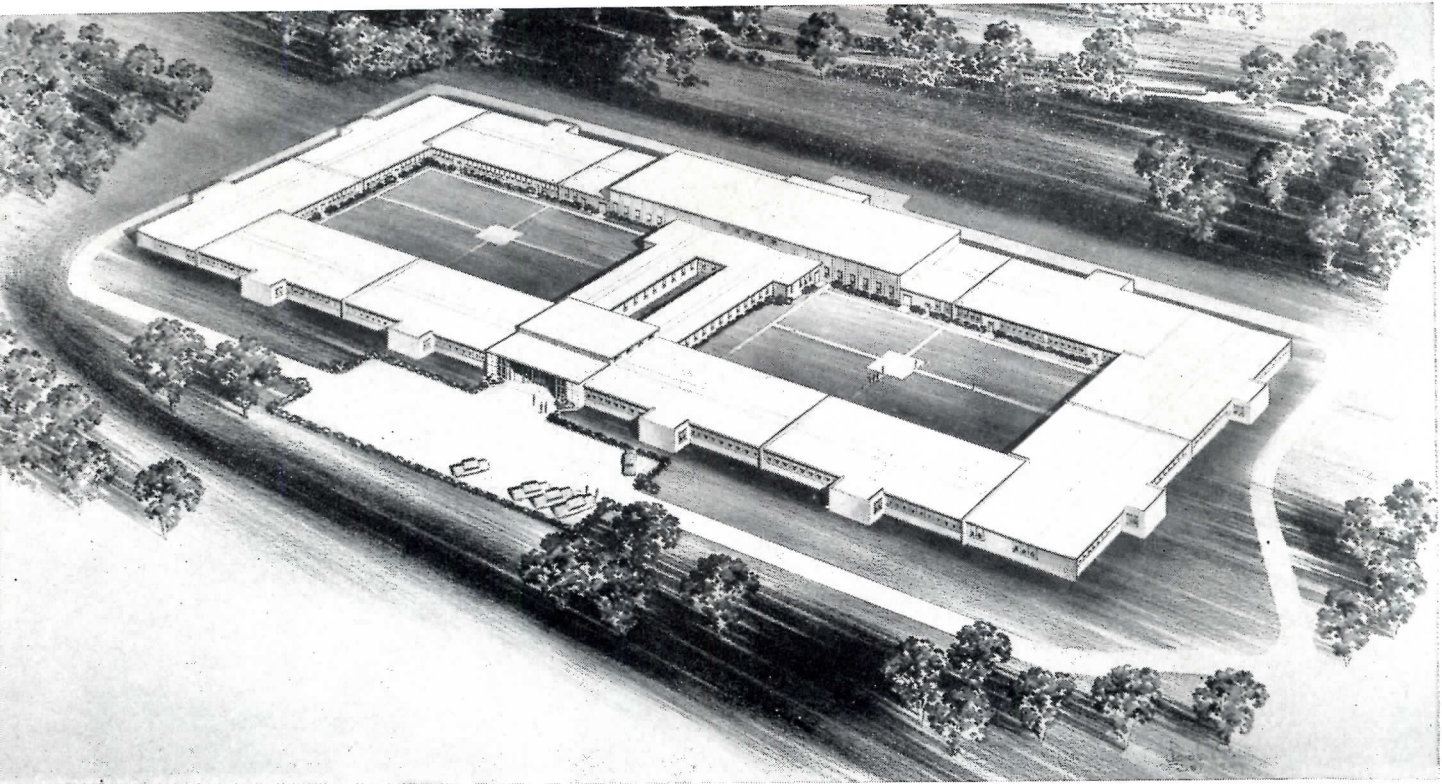

**Milledgeville State Hospital, Milledgeville, Georgia  
1000-bed Psychiatric Building No. 2**

Equipped with Sarcotherm Weather-Compensated Control System for radiant heating. Architects — Gregson & Associates, Atlanta, Ga. Mechanical Engineers — Ammons, McClure & Caldwell, Atlanta, Ga. General Contractor — Jordan Contracting Company, Columbus, Ga. Mechanical Contractor — Spivey Plumbing & Heating Co., Milledgeville, Ga.

**OTHER ADVANTAGES  
OF SARCO THERM SYSTEMS**

**Application engineering** — Sarcotherm engineers, backed by years of experience in heating control systems, assist consulting engineers with individualized system diagrams.

**Easy to install** — special installation drawings and diagrams of the complete system are furnished for each job.

**Easy to maintain and adjust** — by regular maintenance men, because of construction simplicity, fewer parts.

**On-the-job assistance** — to contractors from Sarcotherm's field engineers.



**FOR COMPLETE CONTROL SYSTEM CATALOG**, write . . . Sarcotherm Controls, Inc., Empire State Bldg., New York 1, N. Y.

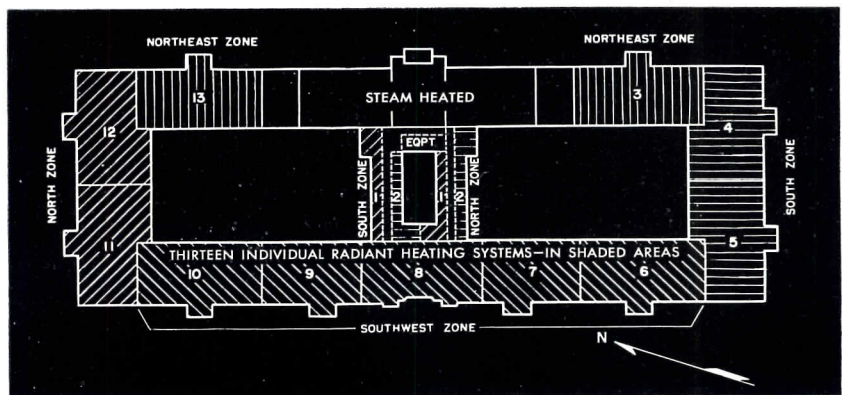

**Details of heating system**

Building supplied with medium pressure steam from boiler house about 3000 feet away.

Steam supplies direct heat to unit heaters (black area) and indirect heat, through four heat exchangers, to 13 individual floor type radiant heating systems (shaded areas), each of which has its own pump.

Radiant heating systems consist of serpentine coils of 3/4 inch wrought iron pipe imbedded in the concrete floor.

# Sarcotherm

AN AFFILIATE OF SARCO CO., INC.

4011-B

STEAM, HOT WATER AND RADIANT HEATING



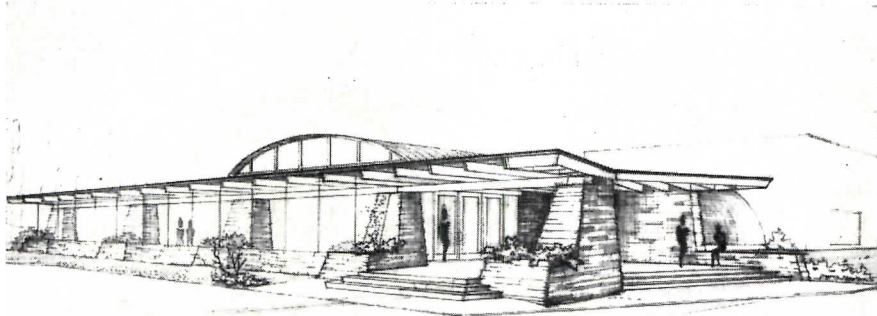

An auditorium constructed of a self-supporting steel shell is the first step in a three-stage building program which will provide attractive modern quarters for a small community theater group in Warren, Ohio. Architect Thomas A. Schroth, a member of the troupe, has planned for the shell to gradually become a secondary element in the overall scheme of the Trumbull Theater as other permanent units — scenery dock and dressing rooms, gallery area and lobby, and stage house — are added.

The auditorium, now completed, was constructed of 10 by 2 ft *Lok-Rib* steel

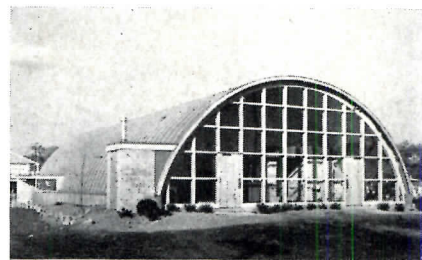

panels made with seven inch ribs and cap sections which, when assembled, formed strong box girder arches at 2 ft intervals along the shell. The simplicity of this shell construction resulted in substantial savings, both in time and costs, allowing apron stage, seating area, rest rooms, projection booth and ticket office to be housed in a structure costing only \$25,000. Present seating capacity is 168.

A partition of cement block and vertical slatting divides the lobby from the auditorium. Interior ceiling arches on both sides of the partition are covered with exposed aluminum foil insulation, held in place by an overlaid network of black enameled steel mesh.

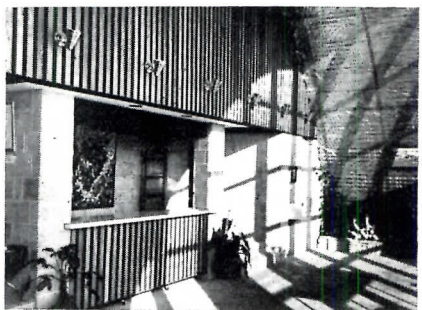

Stage lighting is controlled from a bridge at the rear of the auditorium, while the seating area is illuminated by six aluminum-cone downlights, with conduit concealed in the ribs of the metal arches. The auditorium is heated by a perimeter heating system which supplies warm air through tile ducts beneath the flooring, and ventilated by a 24 in. ventilating fan.

# THEY Go Together...



... THE COMBINATION OF STONE AND

## Shakertown® SIDEWALLS

One complements and enriches the other. The accent colors of the shakes combine beautifully with the rugged texture of stone. The effect is rustic . . . alive . . . appealing. Now there are *twelve* rich Shakertown "pre-stained" colors—including four new, exciting shades for 1957.

Write for your FREE "Shakertown Ideas — 1957"

see our catalog in  
  
 or write for copy

**Shakertown®**  
 FIRST NAME IN CEDAR SHAKES

**THE PERMA PRODUCTS COMPANY**

20310 KINSMAN ROAD • CLEVELAND 22, OHIO



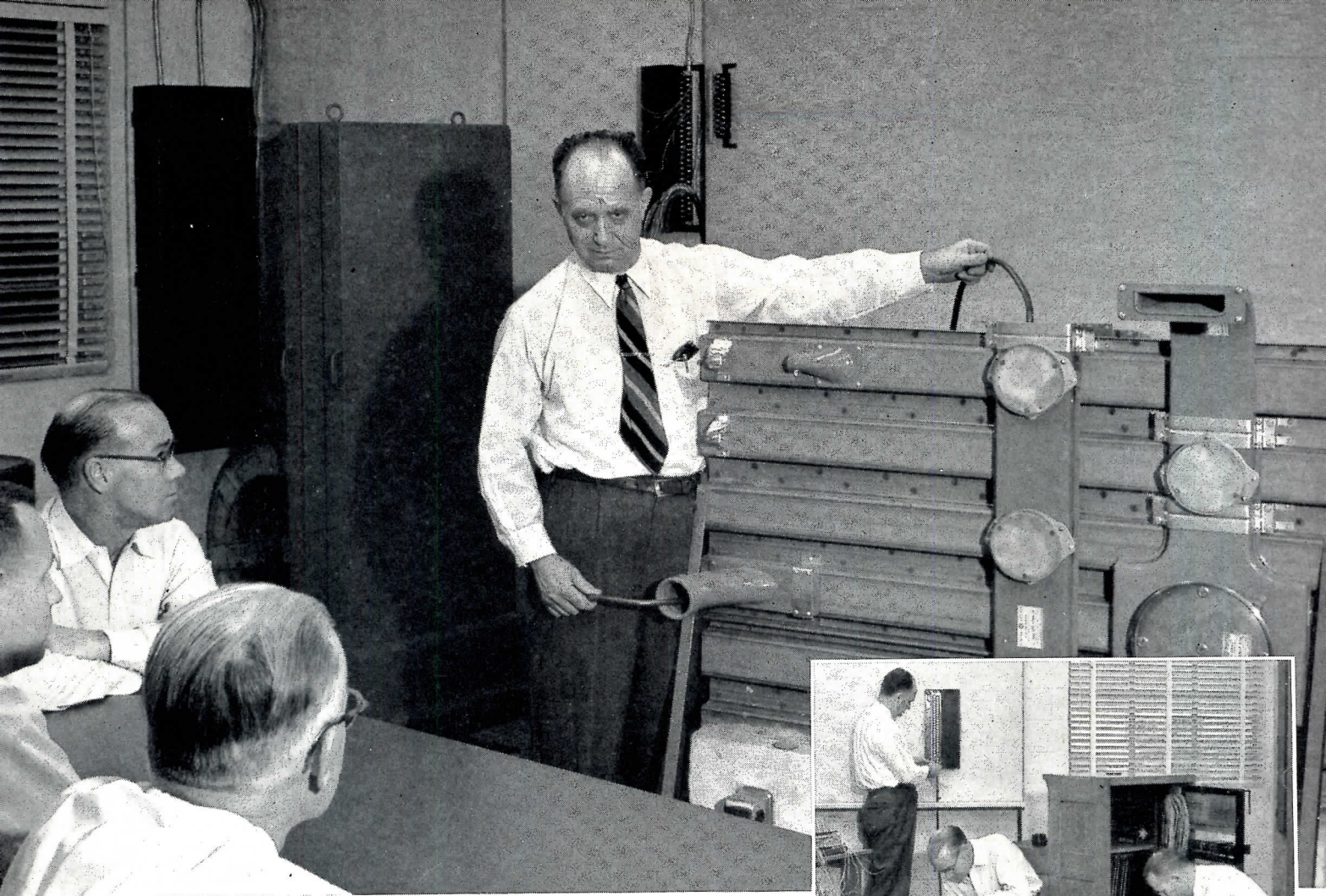

(Above) Demonstrating with a large sample section, Pennsylvania Bell Telephone Company School instructor explains to technician-students the basic principles of Q-Floor wiring. (Right) Members of the Q-Floor class become familiar with the product's advantages by wiring an actual installation in the classroom.

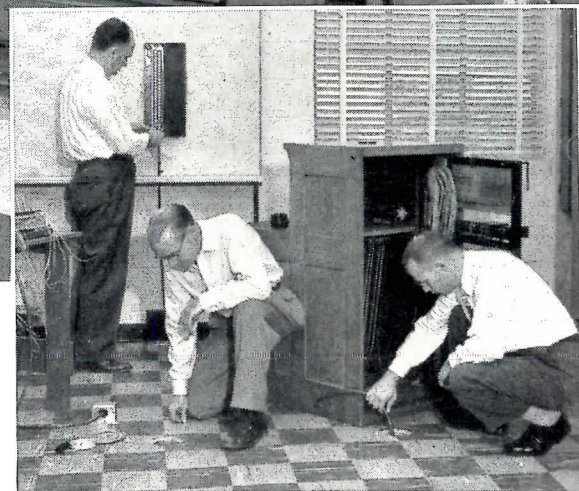

## Q-Floor... a Required Subject at this School

Every year, an estimated 1,600 Bell Telephone Company of Pennsylvania technicians attend a special school near Harrisburg, Pa. to learn the latest practice in line and equipment installation. Bell feels that cellular steel subflooring is so important that an entire classroom is devoted to the subject of Q-Floor wiring. Here the students learn by working with an actual Q-Floor installation that wires can be pulled and telephone or electrical outlets established often in a matter of minutes, and that every six-inch area of the entire floor is available for outlet use. This flexibility, so graphically pointed out to Bell students, plus substantial savings in construction time and money has influenced owners and architects all over America to provide for the future by building with Q-Floor today. Use the coupon to write for literature.

*With Q-Floor performing its dual function of a structural subfloor and as a close-module underfloor wiring distribution system, building owners, designers and contractors benefit from construction speed, convenience and complete wiring flexibility.*

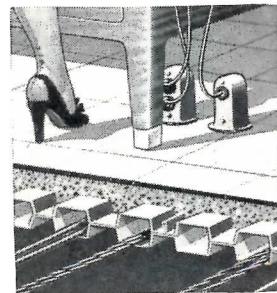

Today's finest buildings are built with **Robertson**  
**Q-Floor**

The STANDARD sub-floor construction for modern buildings

**H. H. Robertson Company**

2404 Farmers Bank Building, Pittsburgh 22, Pa.

In England—Robertson Thain Ltd., Ellesmere, Cheshire

In Canada—Robertson-Irwin Ltd., Hamilton, Ontario • Edmonton, Alberta



Please send 44-page Q-Floor Manual.

NAME \_\_\_\_\_ TITLE \_\_\_\_\_

COMPANY \_\_\_\_\_

ADDRESS \_\_\_\_\_

CITY \_\_\_\_\_ STATE \_\_\_\_\_





*Satinwood, background for elegance...a spirited graciousness*

■ Ralph Cowan, whose name is known nationwide as a synonym for bold imagination and deft artistry in photography, draws out the delicately etched figuring and the molten sheen of Satinwood veneer by Stem in this self-portrait. "Rare wood paneling has a way of being always the same and always different, as your eye unveils the almost iridescent ripples of light below the surface the way it does in this Satinwood panel. It has no equal for providing the perfect background for elegance." As it does for the photographer, Satinwood provides the architect a three-dimensional quality that, together with its ageless patina of molten gold, delights the eye and the spirit of everyone who sees it, for a moment or over many, many years. Through the catalytic artistry of the architect, rare wood panel-

ing and graceful living strike up a happy match. Wherever a background of fine wood is used, its noble presence is felt by all, welding substance and spirit into exciting unity. When rare woods from the forests of the world are used, there is a spirited graciousness—beautiful wood is the essence of peace; it brings serenity to a room in a way that is all its own. Now, Stem brings you, through the magic of modern factory methods, all the nobility, splendor and lifetime permanence of the finest veneer that tradition knows. And you can afford to be generous with this wood, for the cost is low.

*Chester B. Stem, Incorporated  
185 Grant Line Road New Albany, Indiana  
New York — Chicago — Dallas — Los Angeles*

RARE WOODS  
FROM STEM







**PRODUCT REPORTS**

*(Continued from page 244)*

**Motel Communications System**

A "custom engineered" sound system designed especially for motel and hotel use includes such features and services as high fidelity radio or recorded music in every room, an emergency alarm system which sounds in every room, two-way communication in drive-in registration areas, and a maid-locating service. Nerve center of the system is Stromberg-Carlson's SS-800 Communication System, which contains the sound

amplifier, AM-FM high fidelity radios, automatic record changer, and appropriate channel switches. Paging, announcements, radio or recorded music can be transmitted to any or all of the room or areas served by individual speakers. The sound systems are available on a lease plan from *Stromberg-Carlson, Rochester 3, N. Y.*

**Phase Voltage Converter**

Weighing only 39 pounds, the new *Kato* voltage converter changes single phase, 115 volt, 60 cycle AC to three phase, 230 volt, 60 cycle current. Frequency is held constant within a fraction of a cycle.

The aluminum alloy frame houses a capacitor starter as well as both input and output receptacles, and is about 10 inches high. Intake and exhaust air vents are located in lower halves of end-bells, making the converter drip proof. Equipped with vibration dampeners, the machine can be used to change phase and voltage for sound track equipment if placed a few feet away from recording equipment. The new phase converters are available in five sizes ranging from 500 to 2500 watts. *Kato Engineering Company, Mankato, Minn.*

**Whitehall Ferry Terminal Walking Surfaces Are Safe in All Kinds of Weather ...**

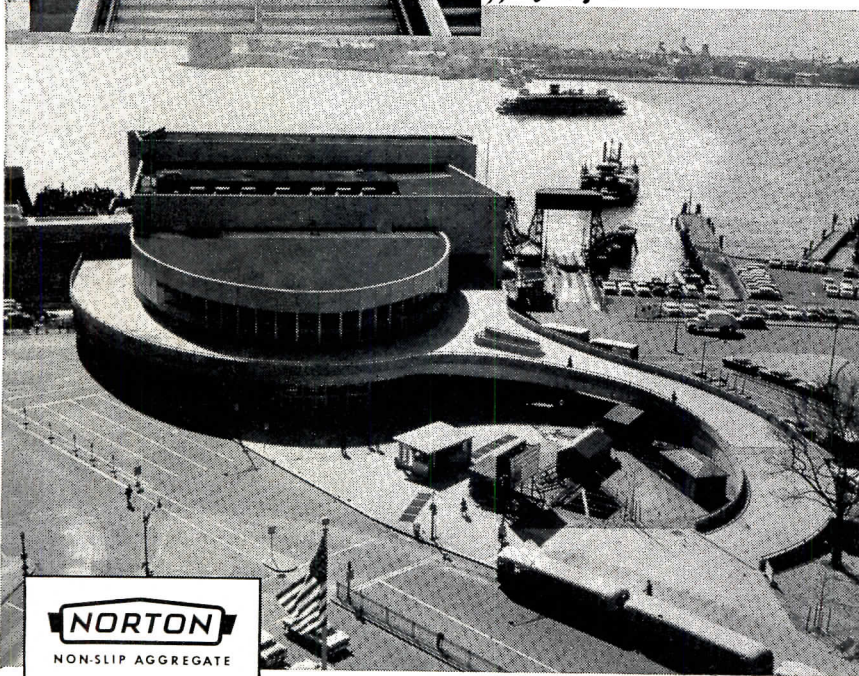
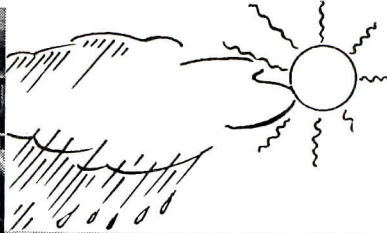

Staten Island Ferry passengers are safe from slipping hazards because of Norton ALUNDUM Aggregate. Outside ramps and platforms have been made permanently non-slip, wet or dry, and wear-resistant by ALUNDUM (C.F.) Aggregate incorporated in cement. Inside surfaces, too, have no slipping hazard because the terrazzo floor areas and stairs contain ALUNDUM Terrazzo Aggregate.

Architect — Roberts & Schaefer Co.  
 General contractor — Frank E. Freeman, Inc.  
 Terrazzo contractor — Ross Tile & Terrazzo Co.

See our catalog in Sweets or write for a copy of No. 1935R

★ **NORTON COMPANY** ★  
**WORCESTER 6, MASSACHUSETTS**

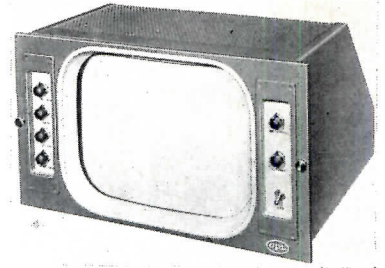

**Video Monitors**

A new line of TV monitors is said to provide bright, clear, high definition pictures for broadcast station or industrial and institutional television picture presentation with closed-circuit systems. Horizontal resolution of all models is in excess of 600 lines; the aluminumized kinescope tubes in the 14, 17 and 21 inch units have 70 degree deflection systems, and the 24 and 27 inch units have 90 degree systems. The monitors are available in both cabinet and rack mounted versions with covers or front panels removable for easy cleaning and servicing. *General Precision Laboratory Inc., Pleasantville, N. Y.*

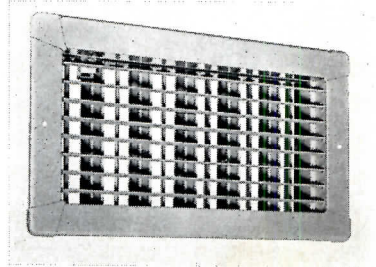

**Air Conditioning Grilles**

*Flexi-Trol*, a new line of air conditioning grilles and registers, consists of four different styles of grilles: single deflection grilles with vertical or horizontal bars, and double deflection grilles with either vertical or horizontal bars in front. Bars are adjustable for complete selection of air diffusion patterns. Available in all standard and many non-standard sizes, the grilles feature one-piece welded construction and a durable baked-on finish. *Lima Register Co., Lima, Ohio. (More Products on page 278)*