

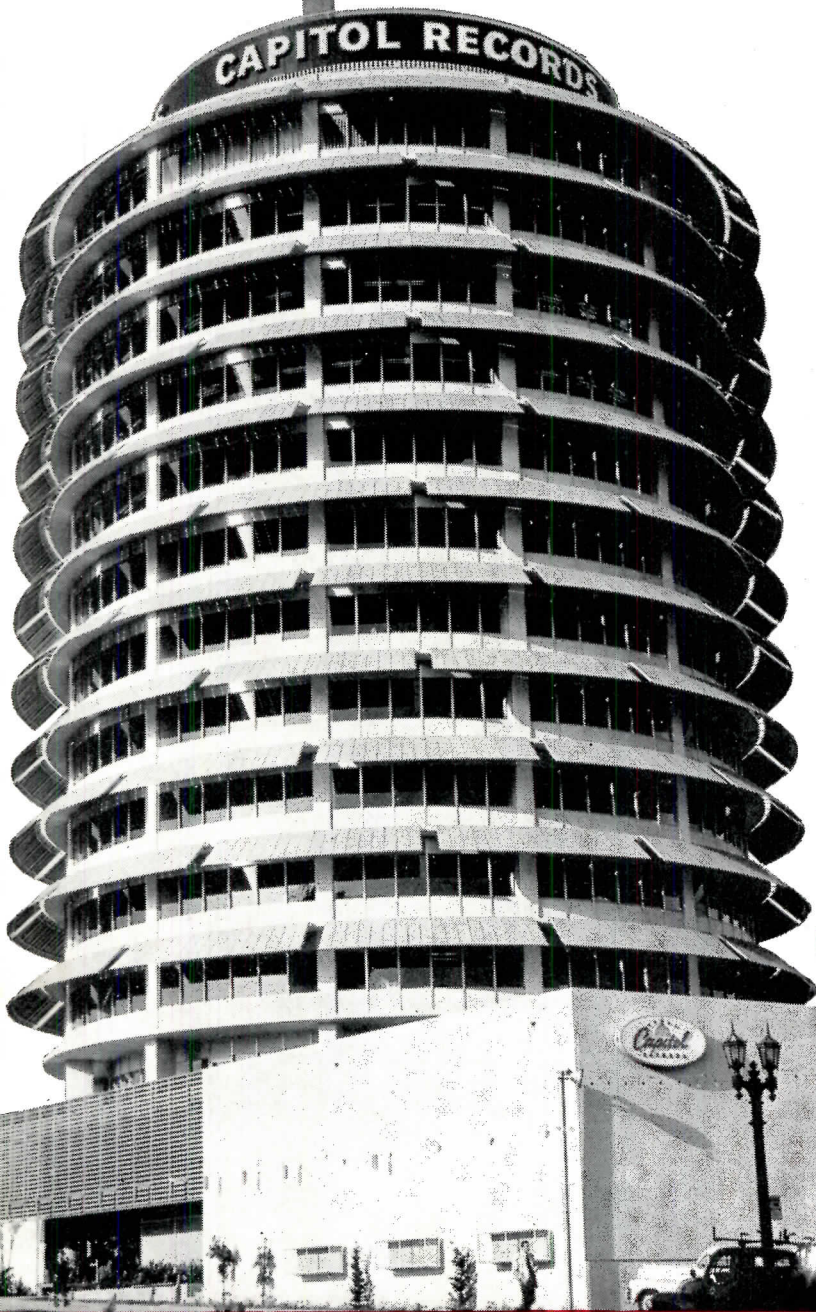

for the world's first circular office building...

architect-engineer specifies **POZZOLITH** to get better quality concrete



Here, as in many other architectural concrete buildings constructed since 1932, Pozzolith was employed to help avoid honeycombing and other segregation defects. A better surface was obtained because of improved cohesiveness and plasticity...even when water was substantially reduced.

Other concrete requirements are also met best with Pozzolith. This is because Pozzolith with its adaptations is key to the control of:

1. **Water content...** makes possible lowest unit water content for a given workability.
2. **Entrained air...** provides optimum air content without sacrificing other desired qualities.
3. **Rate of hardening...** gives desired handling and finishing time under widely varying job conditions.

Any one of our more than 100 skilled field men will be glad to demonstrate the full benefits of Pozzolith for your project, and to advise of the availability of Pozzolith Ready-Mixed Concrete through more than 1000 qualified producers.

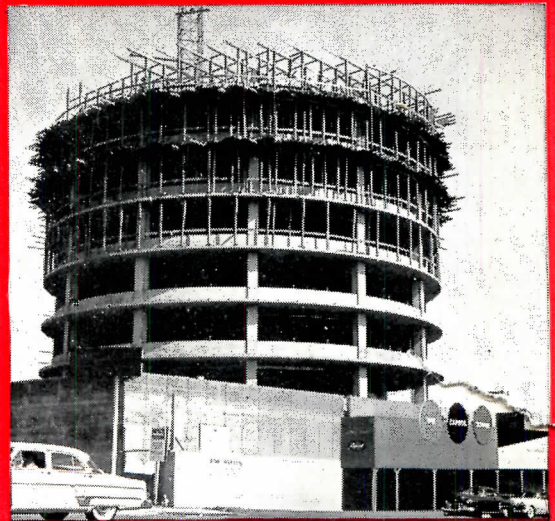

Capitol Records Office Building, Hollywood, California
Architect-Engineer: Welton Becket, F. A. I. A., and Associates, Los Angeles
Structural Engineer: Murray Erick Associates, Los Angeles
General Contractor: C. L. Peck, Los Angeles
Pozzolith Ready-Mixed Concrete Supplied by
Transit-Mixed Concrete Co., Pasadena



THE MASTER BUILDERS CO.

Division of American-Marietta Company

Cleveland 3, Ohio—Toronto 9, Ontario

Cable Address, Mastmethod, N. Y.

January 1957 Vol. 121 No. 1

Copyright 1957 by F. W. Dodge Corporation, with all rights reserved. Copyright not claimed by F. W. Dodge Corporation on color illustrations on page 156 and front cover. ARCHITECTURAL RECORD (combined with AMERICAN ARCHITECT and ARCHITECTURE) is published monthly, except May 1957 when semi-monthly, by F. W. Dodge Corporation, 10 Ferry Street, Concord, New Hampshire. Editorial and executive offices: 119 West 40th Street, New York 18, New York. Western editorial office, 2877 Shasta Road, Berkeley 8, California.

STAFF OF ARCHITECTURAL RECORD



F. W. DODGE CORPORATION H. Judd Payne, *Publishing Director*; Robert F. Marshall, *General Manager*; John Knox Shear, A.I.A., *Editor-in-Chief*; Marshall T. Ginn, *Circulation Manager*; Emerson Goble, *Managing Editor*; Frank G. Lopez, A.I.A., *Senior Editor*; James S. Hornbeck, A.I.A., *Senior Associate Editor*; Elisabeth Kendall Thompson, *Senior Associate Editor and Western Section Editor (Berkeley, California, Office)*; Robert E. Fischer, *Associate Editor (Engineering)*; Florence A. van Wyck, *Associate Editor*; Jeanne M. Davern, *Associate Editor (News)*; Herbert L. Smith, Jr., A.I.A., *Associate Editor*; Ernest Mickel, Dan Street (*Washington*), John Caulfield Smith, M.R.A.I.C. (*Canada*), *Contributing Editors*; Grace M. Anderson, *Assistant Editor*; Margaret R. Fuerst, *Assistant Editor (Engineering Assistant)*; Helen E. Cook, *Editorial Assistant (Production)*; Dianne Thomas, *Editorial Assistant*; Eugene H. Hawley, *Design Director*; Thomas L. McArthur, Mary Ann Godfrey, *Design*; Sigman-Ward, *Drafting Consultant*; Thomas S. Holden, *Industry Relations Consultant*; Clyde Shute, *Statistical Consultant*; George Cline Smith, *Economics Consultant*; Clifford Dunnels, Jr., *Field Research Consultant*; Daniel J. Howe, Jr., *Public Relations Consultant*.

TABLE OF CONTENTS

The Record Reports

Perspectives	9
Buildings in the News	10
On the Road: Two Exhibits of Architecture — Landscape and German	16
Reviewing the Record. Canberra: An International Competition for a National Capital	18
Meetings and Miscellany	21
Architectural Students Hold Second Annual Forum	28
A Washington Report: "Senior Citizens": The Federal Spotlight Finds Them. <i>By Ernest Mickel</i>	32
News from Canada. <i>By John Caulfield Smith</i>	36
Washington Topics. <i>By Ernest Mickel</i>	48
Construction Cost Index	54
Required Reading	71
Calendar and Office Notes	324
Current Trends in Construction	384



Cover: Kellogg High School, Kellogg, Idaho; Perkins & Will; Culler & Gale; Martell & Norrie, Architects; Hedrich-Blessing photo

Courthouse Without Steps

The campus plan is now used for a courthouse, jail, offices in a governmental complex, with everything in small buildings, everything on the ground floor — no stylobate and peristyle, in fact no steps.

Brazos County Courthouse and Jail, Texas; Caudill, Rowlett, Scott & Assoc., Architects 149

A House and a Hill

This house is not in a hill or on a hill; it is a house designed for its own expression, leaving the hill to its own expression, neither disturbing the other.

The Starkey House, Duluth, Minn.; Marcel Breuer, Architect 155

Home for the Aged Competition

Presentations of the award-winning designs, with comments of the jury.

Report of the Jury by Pietro Belluschi, Chairman 161

One Hundred Years of Significant Building

From 100 years of governmental and memorial buildings our nominating panel has chosen only three as "most significant."

8. Civic Monuments 169

Architecture (?) for the National Parks

First report in what promises to be a prolonged series on the Mission 66 program of the National Park Service to increase and improve facilities for the general public visiting the parks. The question mark above is to suggest that there is considerable doubt about the quality of architecture to be expected.

An article by Emerson Goble 173

Building Types Study Number 242 — Schools

Introduction: The Problems of School Sites, by *Frank G. Lopez, A.I.A.* 189

High School, Kellogg, Idaho; Culler, Gale, Martell & Norrie; Perkins & Will, Architects 192

Elementary School, Tambá Hill, Rio de Janeiro, Brazil; Eneas Silva, Architect 207

Tower Street and Westminster Street Elementary Schools, Westerly, R. I.; Harriman, Willis and Hayden, Architects-Engineers 208

Fort Sanders Elementary School, Knoxville, Tenn.; Painter, Weeks & McCarty, Architects 216

Proposed Elementary School, Pleasant Grove, Utah; W. Rowe Smith, Architect 218

More About Maximlite Schools. By *Frank G. Lopez, A.I.A.* 219

Architectural Engineering

Plastic — Limit Design of Steel Frames. By *Edward Cohen* 221

New Types of Wood Roof Trusses. By *Howard E. McCall* 226

Technical Roundup 230

Product Reports 231

Literature 232

Time-Saver Standards: Steel Door Frame Details: 1, 2 & 3. By *E. E. Ellwood* 235

Index to Advertising

386

OFFICERS OF THE F. W. DODGE CORPORATION

James McV. Breed, *Chairman of the Board*; Paul Abbott and Thomas S. Holden: *Vice Chairmen of the Board*; Howard Barringer, *President*; Irving W. Hadsell, Chauncey L. Williams: *Executive Vice Presidents*; Howard M. Thompson, *Vice President and Treasurer*; Julius T. Little, Robert F. Marshall, T. Oliver Morgan, O. O. Paulsell, H. Judd Payne, George Cline Smith: *Vice Presidents*; Carl S. Bennett, Clinton C. Bennett, Ralph M. Hairston, Roy J. Hard, Arthur D. Prior, Richard H. Ray, John M. Williams: *Regional Vice Presidents*; Edwin H. Freed, *Assistant Vice President and Comptroller*; Walter F. DeSaix, Clifford G. Dunnells, Jr., Gault Eastman, Clyde Shute, Marc Wayne: *Assistant Vice Presidents*; Sanford D. Stockton, Jr., *Secretary*; William C. Breed, Jr., George W. Morgan, Jr.: *Assistant Secretaries*; Irving B. Satin, *Assistant Treasurer*.

OTHER F. W. DODGE SERVICES

Dodge Reports — Dodge Statistical Research Services — Sweet's Catalog Services — Dodge Books — Dodge Mailing Service — The Modern Hospital — The Nation's Schools — College and University Business — Hospital Purchasing File — Chicago Construction News — Daily Pacific Builder — Denver Daily Journal — Real Estate Record & Builders Guide.

Members of Audit Bureau of Circulations and Associated Business Publications. ARCHITECTURAL RECORD is indexed in Art Index, Industrial Arts Index and Engineering Index.

Every effort will be made to return material submitted for possible publication (if accompanied by stamped, addressed envelope), but the editors and the corporation will not be responsible for loss or damage.

Subscription prices: Published monthly except May 1957 when semimonthly. U. S., U. S. Possessions and Canada: \$5.50 per year; other Western Hemisphere countries, Spain, to those who by title are architects and engineers, \$9.00 per year. Single copy price except Mid-May 1957 issue \$2.00; Mid-May 1957 issue \$2.95. Beyond Western Hemisphere, excluding Spain, to those who by title are architects and engineers, \$9.00 per year for 12 monthly issues not including Mid-May 1957 issue. Subscriptions from all others outside U. S., U. S. Possessions and Canada for 12 monthly issues, not including Mid-May issue, \$24.00 per year. Changes of address: subscribers are requested to furnish both old and new addresses, sending if possible stencil impression from magazine wrapper; allow four weeks for change.



THE RECORD REPORTS

P E R S P E C T I V E S

A NEW CENTURY BECKONS: This month opens the Centennial Year of the American Institute of Architects, and very special plans are afoot to celebrate the profession and the organization which can fairly claim to have made it one. The New York Chapter, by accident of geography, will have perhaps the most evocative event on the calendar, when it puts a bronze commemorative tablet on the building at 111 Broadway in downtown Manhattan, site of the building where the organization meeting of the A.I.A. was held in the offices of Richard Upjohn, on Feb. 23, 1857. If ghosts do walk, surely the Chapter can expect as unseen guests on Feb. 23, 1957 the little group of 13 men who made up that momentous inauguration — besides Mr. Upjohn, his son, Richard M. Upjohn, Edward Gardiner, H. W. Cleaveland, J. Wray Mould, Leopold Eidlitz, Henry Dudley, Fred A. Petersen, Charles Babcock, Joseph C. Wells, Richard M. Hunt, John Welch, J. W. Priest. As its first century ends, the Institute can report 11,500 members in 124 chapters and 11 state organizations, all of them pledged to support the objectives now written into the A.I.A. bylaws — “to organize and unite in fellowship the architects of the United States of America; to combine their efforts so as to promote the esthetic, scientific and practical efficiency of the profession; to advance the science and art of planning and building by advancing the standards of architectural education, training and practice; to coordinate the building industry and the profession of architecture to insure the advancement of the living standards of our people through their improved environment; and to make the profession of ever-increasing service to society.” These objectives are the heart of the planning for the climactic event of the Centennial Year, the A.I.A. Centennial Celebration Convention in Washington, D. C., May 14-17. “A New Century Beckons” is the theme, and

the effort is to assemble as speakers those distinguished personages in all appropriate fields outside of architecture who are best qualified to discuss the forces which will shape man's environment in the years ahead. The initial announcement on the program sets a lofty — and challenging — goal: “It is recognized that the forces which shape human environment are infinitely more complex today than at any time in the past century. . . . In the contrast provided by the two areas, we may see, if only dimly, the enormity of the task we face. Our vast new knowledge of the nature of matter must be matched by an equivalent understanding of the nature of man. The architect can and must contribute to a closure of this gap in knowledge.”

CHICAGO GETS THE SHAFT: Prof. C. E. Stousland, chairman of the Department of Architecture at Miami University (Oxford, Ohio), offers these thoughts on recent architectural news:

the man is on the tv
with cape and flowing mane
the cowboy from Wisconsin
has shocked us all — again
they asked him — are you kidding
and yet nobody laughed
its not a thing to laugh at
when Chicago gets the shaft
the critics still are silent
tho not for long i trust
lets establish a cry
for this thing in the sky
like fifty-two eighty or bust
ill give you odds
and make a bet
that
mr otis
wont regret

SIGNIFICANT AMERICANA, the British *Architectural Review* says of the RECORD's current series “One Hundred Years of Significant Building” (June 1956 *et seq.*); and of the panel whose nominations established the buildings to be shown: “practically

everybody who is anybody in U. S. architecture” (a rather extreme example of amiable hyperbole). But after listing the first eleven buildings, and noting that two Sullivan buildings (Carson Pirie Scott and Wainwright) tied for first place, the *Review* has at American architectural taste in considerably less amiable (though perhaps no less hyperbolic) terms: “It is clear that Louis Sullivan is still the preferred native genius, and the choice of those two buildings suggests that American opinion in architecture is still performing its (apparently constituent) two-way stretch between classicism and empiricism, for the Wainwright Building is Beaux-Arts stretched to breaking, and held together by the will of a Master, while the dead-regular flat-face grids of Carson Pirie Scott are the same Master's pre-vision of a statistical rentable democracy.” On second thought, is that as bad as it sounds?

H. H. S. SIGNING OFF, the signature on “The Editor's Asides” section of the December issue of the *Journal of the American Institute of Architects*, wrote “thirty” to a career in architectural editing that had spanned more than half a century. Henry Hodgman Saylor, dean of American architectural editors, was saying his farewell, in characteristically modest and quietly puckish fashion, to the publication he founded 13 years ago and nurtured to the status of an institution in the architectural world. Henry Saylor's retirement as editor of the A.I.A. *Journal* will not end his labors for it — he is presently engaged in preparing a series of articles on the history of the A.I.A. and these will be a major feature of the *Journal* in this Centennial Year of the A.I.A. Mr. Saylor has already had the highest honors the A.I.A. can give him — Fellowship, and, in 1954 the Edward C. Kemper Award for Service to the Institute. Now, at his retirement, his friends can only add their wishes for long and fruitful “golden years.”

TEXAS AWARDS HONOR NINE: TWO MILLION SEE EXHIBIT

Deep in the heart of Texas they make a really big thing of their annual state honor awards program, treating it not just as an architectural event but as the occasion for one of the biggest public relations efforts of the year. So, each year, the statewide competition is based on an exhibition carefully and prominently installed at the State Fair of Texas in Dallas. Harwood K. Smith of

Dallas was general chairman of this year's edition, "Texas Architecture — 1956," which was seen by an estimated two million visitors to the Fair. Honor Awards went to the nine projects shown here — three houses, two schools, a bank, an office building, a college building and a parish hall. The honor award display was on view at the annual convention of the Texas Society of Archi-

tecs and is scheduled to tour the architectural schools of Texas. Members of the competition jury, in addition to Mr. Smith, were: Arthur Gallion, architect and dean of the School of Architecture of the University of Southern California; architect Kenneth K. Stowell, of New York City, Los Angeles; and architect William B. Harvard, A.I.A., of St. Petersburg, Fla.

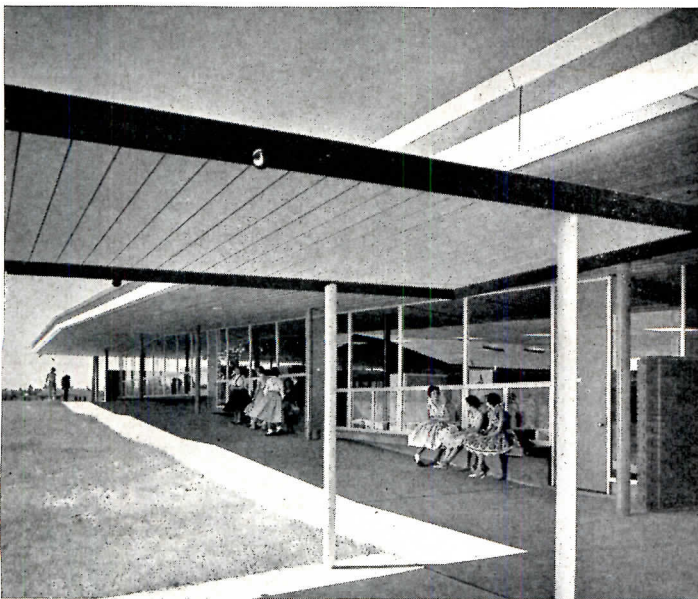
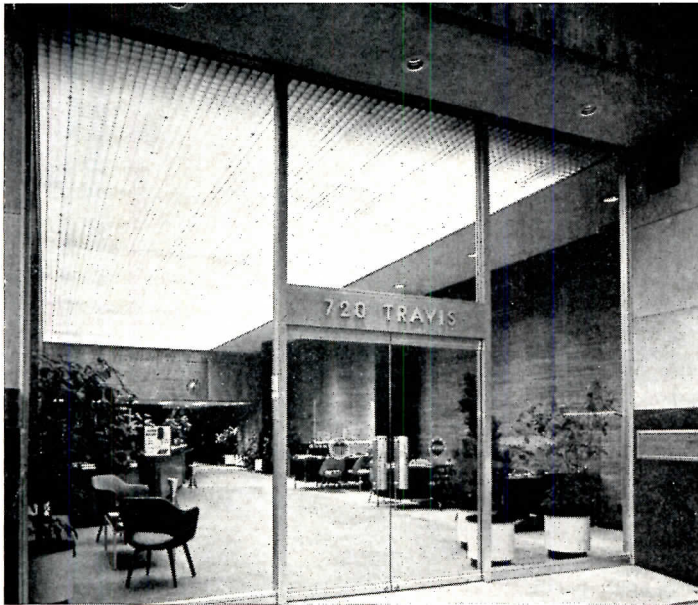

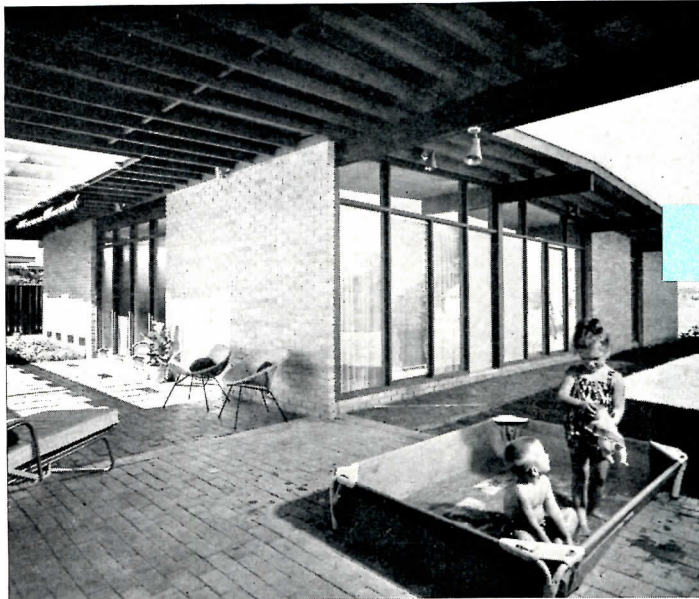
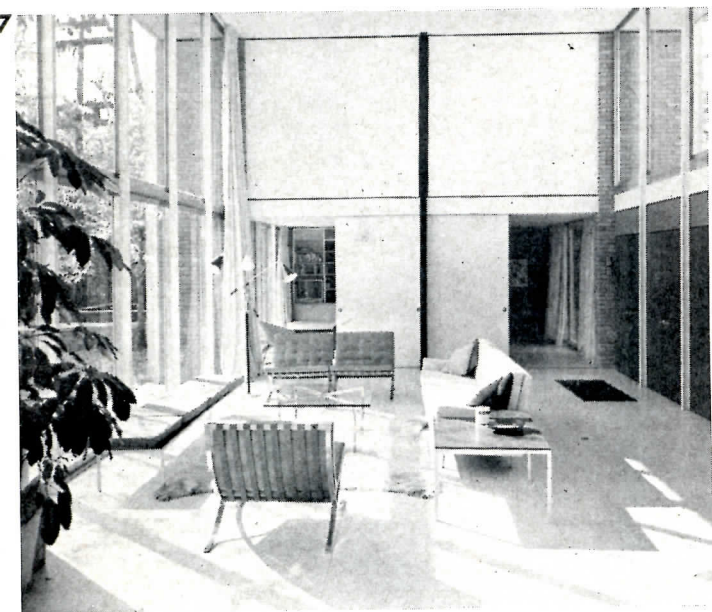
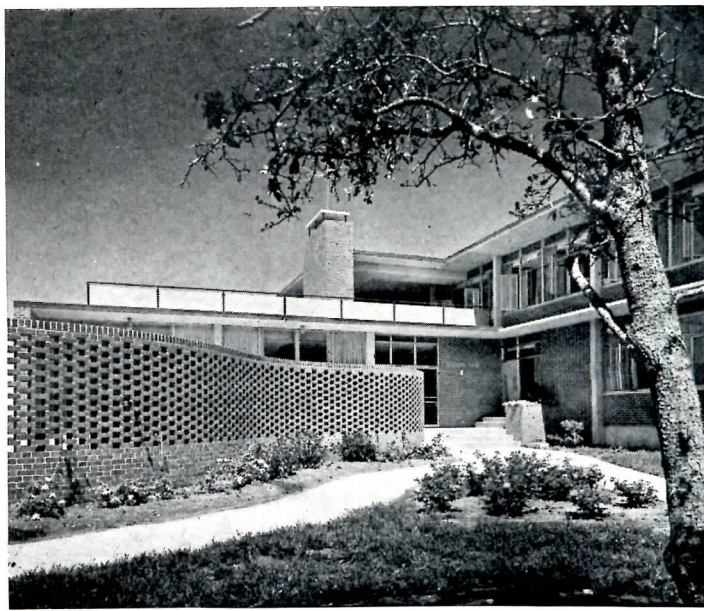
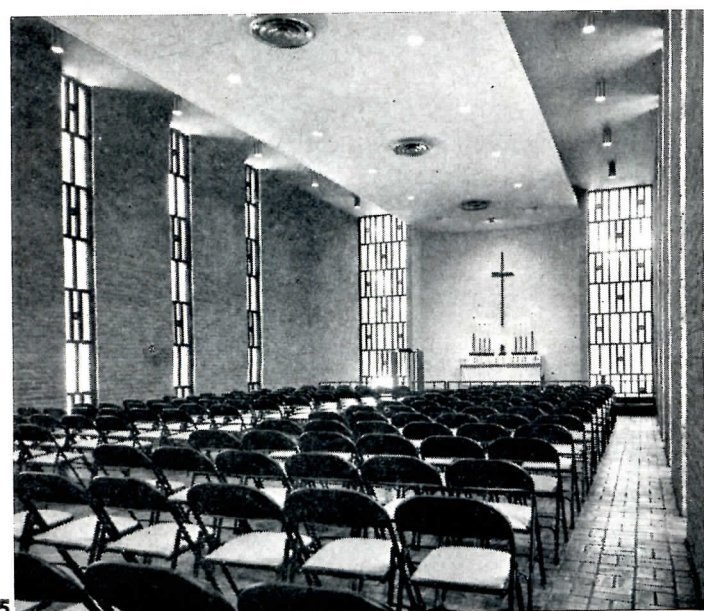

1. Benjamin Franklin Savings and Loan Association, Houston; Wilson, Morris and Crain. 2. Plant Office Building, Kirby Lumber Corporation, Silsbee; George F. Pierce and Abel B. Pierce. 3. J. R. Moore Junior High School, Tyler; Caudill-Rowlett-Scott, Bruce and Russell. 4. Matie L. Jones Elementary School, Tyler; E. Davis Wilcox Associates. 5. Parish Hall, Holy Cross Lutheran Church, Houston; Paul H. Elliott. 6. Clifton Hall, Texas Lutheran College, Seguin; Fehr and Granger (George Zapalac, project coordinator). 7. Residence for Mr. and Mrs. Gerald Gordon, Houston; Bolton and Barnstone. 8. Residence for Mr. and Mrs. William Micchelli, Dallas; E. G. Hamilton. 9. Residence for Mr. and Mrs. Arthur Berger, Dallas; O'Neil Ford



(More news on page 12)

Photos: F. W. Seiders, Ulric Meisel, Roland Chatham, Fred Winchell, Dewey G. Mears, Hedrich-Blessing

THE RECORD REPORTS

BUILDINGS IN THE NEWS

(Continued from page 11)

MORE TOWERS FOR NEW YORK: MAJOR PROJECTS ANNOUNCED

Two more skyscrapers (see cuts) designed by architects Harrison & Abramovitz will rise in Manhattan's Rockefeller Center area.

One, the Time & Life Building, to cost an estimated \$70 million, will actually constitute an extension of Rockefeller Center — its first west of Avenue of the Americas — to occupy a site 200 ft on Avenue of the Americas, from 50th to 51st streets (opposite Radio City Music Hall), by 410 ft, west to the Roxy Theater. A landscaped plaza 200 ft long and 80 ft wide will give access to the main entrance. Use of air rights above the Roxy Theater, which is owned by Rockefeller Center, Inc., is credited with a 50 per cent increase in tower floor areas, making them the largest in New York.

The 60-story skyscraper planned for 33 West 51st Street will occupy a site approximately 200 ft (on Avenue of the Americas between 51st and 52nd streets) by 450 ft (eastward on 51st and 52nd Streets). It too will have its "garden plaza forecourt."

COOPER UNION PLANS FOR A NEW ENGINEERING BUILDING

New York's Cooper Union, oldest privately endowed tuition-free college in the nation, will build a glass, steel and concrete engineering building (photos of renderings at right) as the major feature of a \$7.5 million development and modernization program planned to mark its Centennial in 1959. Modernization of existing buildings under the program will, for one thing, provide the space needed to "enable the Art School to take its long-anticipated step toward degree-granting status in architecture and design," President Edwin S. Burdell noted.

The basic plans for the new building were developed by Prof. Esmond Shaw, Chairman of the Department of Architecture at Cooper Union, in association with the architectural firm of Harrison & Abramovitz. Three six-story wings — one raised two stories above ground so that its height is equivalent to eight stories — will house laboratories, classrooms and offices respectively; a separate wing will contain two lecture rooms of 160 seats each. Administrative offices and a student lounge will have ground-floor locations; all heavy equipment for the chemical, civil and electrical engi-

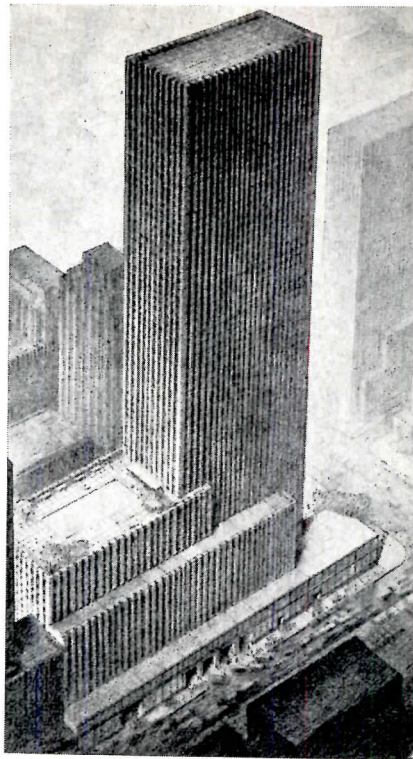

30 WEST 51 — 60-story office building to be built by real estate developers Peter B. Ruffin and John W. Galbreath will be seventh tallest (775 ft) New York skyscraper. Like the Socony-Mobil building, which had the same owners and the same architects, it will be sheathed in stainless steel. Architects: Harrison & Abramovitz. Builder: Turner Construction Company

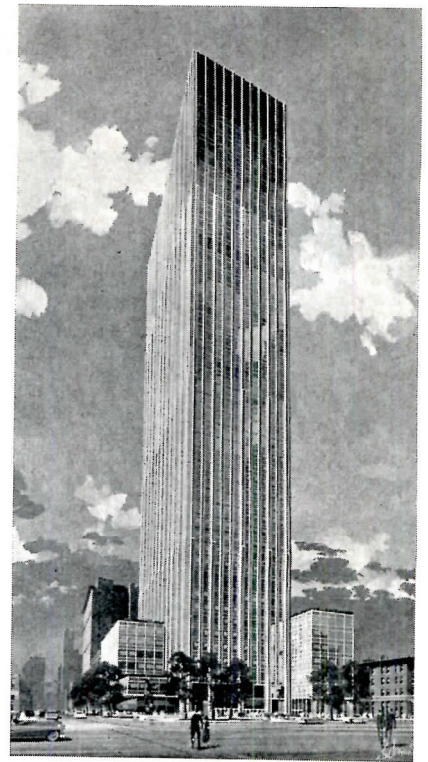

TIME & LIFE Building — 47-story office building to be built jointly by Rockefeller Center Inc. and Time Inc., with Time to occupy 600,000 of the projected 1,400,000 sq ft of rentable space, will have the largest tower floors — 32,549 sq ft — of any New York building. Architects: Harrison & Abramovitz. Builder: George A. Fuller Company and John Lowry Inc.

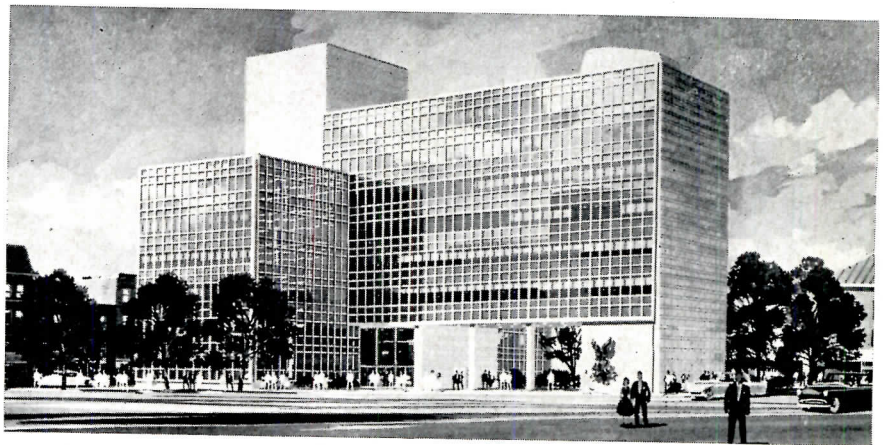

neering departments will be housed in the basement.

Site of the new building, already cleared, is across Astor Place from the Cooper Union's "Foundation Building" (visible at lower left in aerial view), for which Peter Cooper had made the first rolled iron beams ever fabricated for structural use. The first batch, and several succeeding ones, were sold off the site for other buildings, but Peter Cooper's building was eventually built with rolled iron beams among many other structural innovations.



(More news on page 16)

ELEVATOR CORRIDOR . . . NURSES' HOME

the flooring spec: Armstrong Custom Corlon Tile

DURABILITY

This is New York headquarters of the largest mining company in Peru. Visitors get a friendly first impression the moment they step off the elevators in the new Colgate-Palmolive Building on Park Avenue. Much of the welcoming atmosphere is created by the floor of Custom Corlon Tile inset with bright brass strips. This homogeneous vinyl floor will withstand years of concentrated foot traffic without losing its good looks.

Cerro de Pasco Corporation, Executive Offices, New York City
interior design: Leigh Allen, Designer — J. Gordon Carr

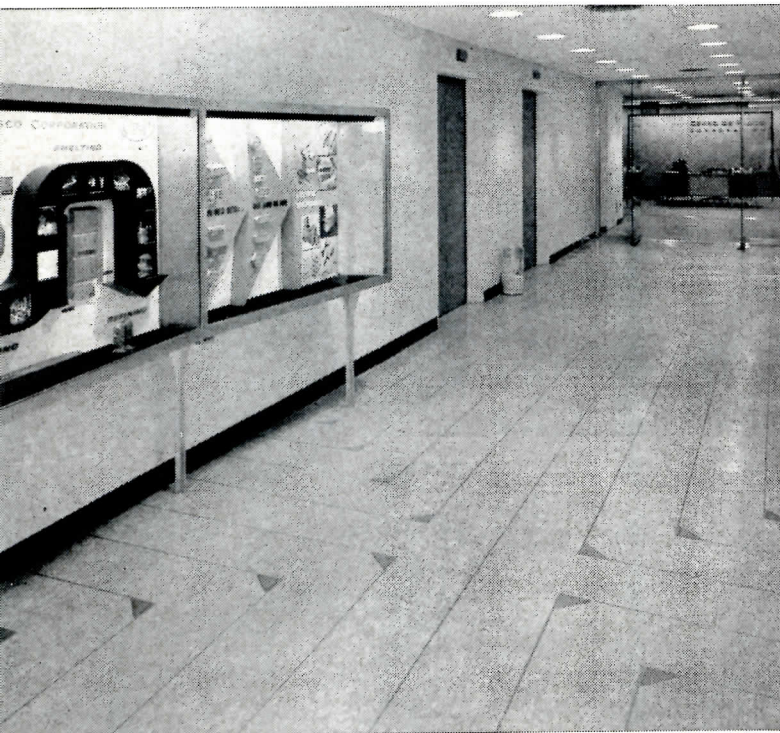

COMFORT

The refreshing elegance and style of this nurses' home are just what the doctor ordered—as a change from the businesslike and antiseptic surroundings of a hospital. The nurses say it's relaxing just to walk on the Custom Corlon Tile floor, it's so comfortable underfoot. And the rich colors and burl graining give a look of luxury to lobby, reception areas and bedrooms.

Barton Hall, Protestant Deaconess Hospital, Evansville, Ill.
architect: Schmidt, Garden and Erikson, Chicago

Armstrong Custom Corlon Tile is the ultimate in flooring luxury. Made with highest quality vinyl resins, its dimensional stability and indentation resistance are unexcelled. The rich colors and grainings — Burl or Imperial* Series — make this floor suitable for the finest interiors.

It can be installed over any type of subfloor, even below grade. Highly resistant to grease, oils, and most solvents, Custom Corlon Tile offers savings through easier maintenance and longer wear that offset its higher initial cost.

Because Armstrong makes all types of resilient floors, we can offer unbiased recommendations for every flooring need. For information, samples, complete specifications, design and color scheme assistance, call the Architectural-Builder Consultant in your nearest Armstrong District Office or write Armstrong Cork Co., 1601 Rooney St., Lancaster, Pa.



Armstrong FLOORS

Approximate Installed Prices per Sq. Ft. (Over concrete, minimum area 1000 sq. ft.)

<p>20¢ to 35¢</p>	<p>Asphalt Tile, 1/8" (A, B, C, D) Linoleum, light gauge Asphalt Tile, 3/16" (A, B)</p>	<p>35¢ to 45¢</p>	<p>Linoleum, standard gauge Asphalt Tile, 3/16" (C, D) Linoleum, heavy (1/8" gauge) Greaseproof Asphalt Tile</p>	<p>45¢ to 60¢</p>	<p>Corlon (Sheet Vinyl) Linoleum, 1/8" Cork Tile, 1/8" Excelon® Tile (Vinyl-Asbestos) 1/8"</p>	<p>60¢ to 70¢</p>	<p>Rubber Tile, 1/8" Cork Tile, 3/16" Linoleum® Corlon (Hydrocord* Back)</p>	<p>70¢ to 90¢</p>	<p>Custom Corlon Tile (Homogeneous Vinyl) 3/32", 1/8" Cork Tile, 5/16" Rubber Tile, 3/16" Corlon (Cushion-Eze* Back**)</p>	<p>90¢ to \$1.20</p>	<p>Custom Vinylcork* Tile Imperial Custom Corlon Tile</p>
---------------------------	---	---------------------------	--	---------------------------	--	---------------------------	--	---------------------------	--	------------------------------	---

*TRADE-MARK
**PATENT PENDING

ON THE ROAD: TWO EXHIBITS OF ARCHITECTURE—LANDSCAPE AND GERMAN

LANDSCAPE ARCHITECTURE TODAY is an exhibit planned jointly by the California Redwood Association and the Smithsonian Institution. It is being circulated by the Smithsonian's Traveling Exhibition Service. The exhibit opened in San Francisco in August, and will visit, over the next two years, the Museum of Fine Arts, Montgomery, Ala.; Washington University, St. Louis; J. B. Speed Art Museum, Louisville; Carnegie College of Fine Arts, Pittsburgh, Pa.; Art School and Museum, Fort Wayne, Ind.; (tentative); National Housing Center, Washington, D. C. (tentative); San Francisco; University of Florida, Gainesville; University of Pennsylvania, Philadelphia; and University of Oregon, Eugene. Below: exhibit: 1. detail of swimming pool enclosure, John Carmack, landscape architect; 2. garden, Thomas Church, landscape architect; 3. outdoor living and pool area, Eckbo, Royston & William, landscape architects



Phil Palmer

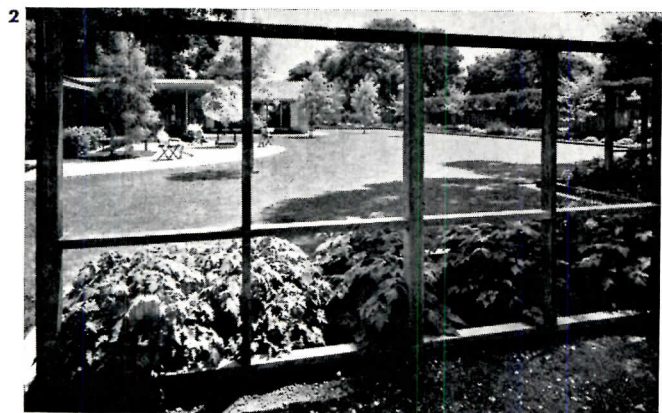

Ernest Braun

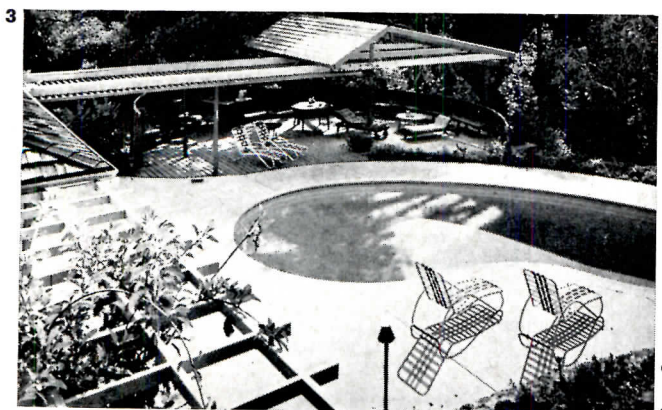

Ernest Braun

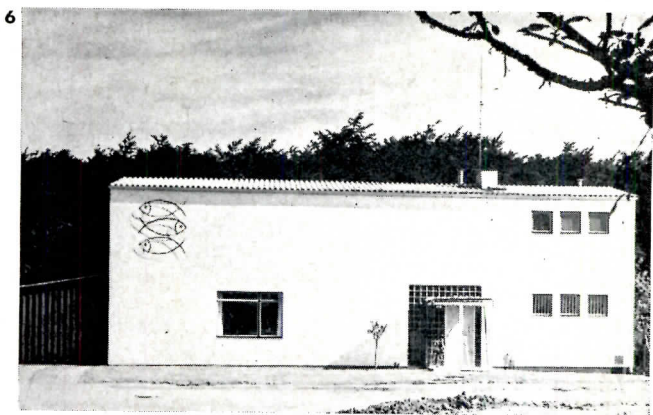
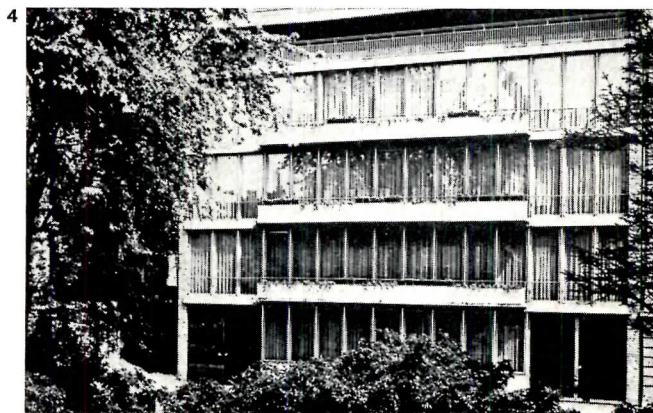

GERMAN ARCHITECTURE TODAY exhibit contains 150 photographs of postwar German building. Sponsored by the German Ambassador and the American Institute of Architects, the exhibition was opened in October at the Octagon, A.I.A. headquarters in Washington, D. C.; it also is being circulated by the Smithsonian Institution, and was scheduled to be seen at Pennsylvania State University, University Park; the Speed Art Museum, Louisville; and the University of Florida, Gainesville. Above: 4. Glass Industry House, Düsseldorf, Bernhard Pfau, architect — glass “used properly and wisely”; 5. housing on the Main at Frankfurt, Max Meid and Helmut Romeik, architects — narrow plan gives living rooms south exposure in rear, north view from tomato red balconies over the river; 6. Architect's own house, Frankfurt, Alois Giefer, architect — closed street elevation conceals rear open for view of garden and forest behind

(More news on page 18)



Gymnasium, LaSalle Senior High School, Niagara Falls, N. Y.
 Architects: Sargent, Webster, Crenshaw & Folley, Syracuse, N. Y.
 Cannon, Thiele, Betz & Cannon, Niagara Falls, N. Y.

For safer daylighting, specify fire-retardant panels made with **HETRON[®]**

Now you can choose the bold, colorful sweep of polyester daylighting panels—with assurance of safety.

The panels you see here will not support combustion. They are made with HETRON. Their inherent flame retardance is achieved without loss of strength or other good qualities.

Panels made with HETRON polyester are the only ones listed and labeled by Underwriters' Laboratories and approved by Factory Mutual Laboratories, after extensive flame tests.

When you want the utmost in beauty, safety, and strength, specify panels with HETRON in them. Your

contractor can get them now, under different brand names, from nearly all leading fabricators. If you'd like specific data on the basic HETRON resins which we make, or the names of manufacturers of these panels, write us.

HETRON...*the flame-retardant polyester*

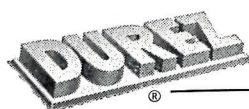

DUREZ PLASTICS DIVISION

HOOKER ELECTROCHEMICAL COMPANY
 5201 Walck Road, North Tonawanda, N. Y.

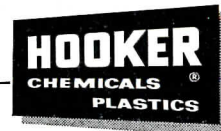

663W32

The State of Construction

Although the month of November was the third in a row to show a drop in awards below the same three months in 1955, according to a report from F. W. Dodge Corporation, the end of November also showed a record-breaking 11-month total of \$22,836,733,000, \$908,544,000 short of the record 1955 12-month figure; contracts awarded in December 1955 totaled \$1,920,754,000. In November 1956, awards at \$1,689,261,000 were down six per cent below awards in November 1955. Losses were recorded in both residential and heavy engineering categories, a gain of eight per cent in non-residential. For details, see page 384.

BRI and Glass

Architects and engineers attending the two-day research correlation conference on "Windows and Glass in the Exterior of Buildings," conducted by the Building Research Institute November 14 and 15, expressed growing concern over the problems accompanying the use of large areas of glass in buildings. The consensus of many speakers was that insufficient attention has been paid to the functional aspects of window design which are essentially to let light in, to let people see through while keeping bad weather out. With or without the air conditioning in buildings, the use of windows for ventilation was questioned

by several speakers. At the same time others showed how windows could be properly used to encourage natural ventilation. Whether windows are needed to provide daylight for seeing also was debated. In office buildings, for example, it was felt that electrical illumination provided the best source of light for seeing. In smaller buildings such as schools and residences it was shown how light-controlling glass block could be used to compensate for the vagaries of sunlight. A prominent school designer felt that irrespective of the use of daylight for seeing, some sunlight coming into school rooms was desirable for its stimulating effect. One architect suggested that perhaps even the shapes of windows today are illogical, having evolved from the double-hung sash and resulting in a tall window which lets in sky glare. The cost of providing complete air conditioning for buildings, especially when large areas of glass are used, unshaded, provoked numerous comments and suggestions concerning orientation of buildings, size and shape of windows, exterior and interior shading devices, mechanisms for the control of lighting and of air conditioning. One engineer estimated that every square foot of unshaded glass (except on the north side) probably adds from \$10 to \$15 to the cost of installing good air conditioning. Architects and engineers participating in the program included:

James Arkin, Thomas A. Bullock, Robert W. Cutler, Leon Chatelain, Jr., Bruno Funaro, William Demarest, Bruce Graham, Alonzo Harriman, John F. Hennessy, Alfred L. Jaros, Jr., William Keck, Morris Ketchum, Jr., James T. Lendrum, Bob Reed, and Henry N. Wright.

Political Action in California

When a hot campaign was being waged in California last November over a voters' proposition concerning the award of contracts for state building, architects in the state took an active and responsible part. The issue was Proposition Number 10, moving that private architects and engineers be employed for state work which the "available staff of a state agency is unable to perform within the time the public interest requires such work to be done." Ranged on the pro side were the state's architects and engineers as well as other members of the construction industry. The supporters of the proposition managed to raise \$90,000 in campaign funds — \$40,000 from California architects, \$10,000 from out-of-state architects, and the remainder from the rest of the building industry. Chief member of the anti, and ultimately victorious side, was the California State Employees Association. Though the architects were disappointed at their defeat, and "just plain mad" about the bitter campaign, they were at the same time encouraged by the unity exhibited in a common cause by members of the architectural and engineering professions, and have reorganized a Joint Architects-Engineers Steering Committee to continue the fight.

With the A.I.A.

A regional picture of architectural activity was taken at the November meeting of the Board of Directors of the American Institute of Architects, and showed building volume either increasing or continuing at a high level in seven of the twelve regions — California-Nevada-Hawaii, New York, Western Mountain, North Central States, Middle Atlantic, Great Lakes and Gulf States. Five regional directors reported a decrease of activity in their areas — Central States, South Atlantic, Texas, New England and the Northwest. In these five regions, the tight money situation was given as the chief reason for decreasing activity. Other subjects on the Board's agenda: *School Buildings* — the committee report recommended that the

(Continued on page 24)

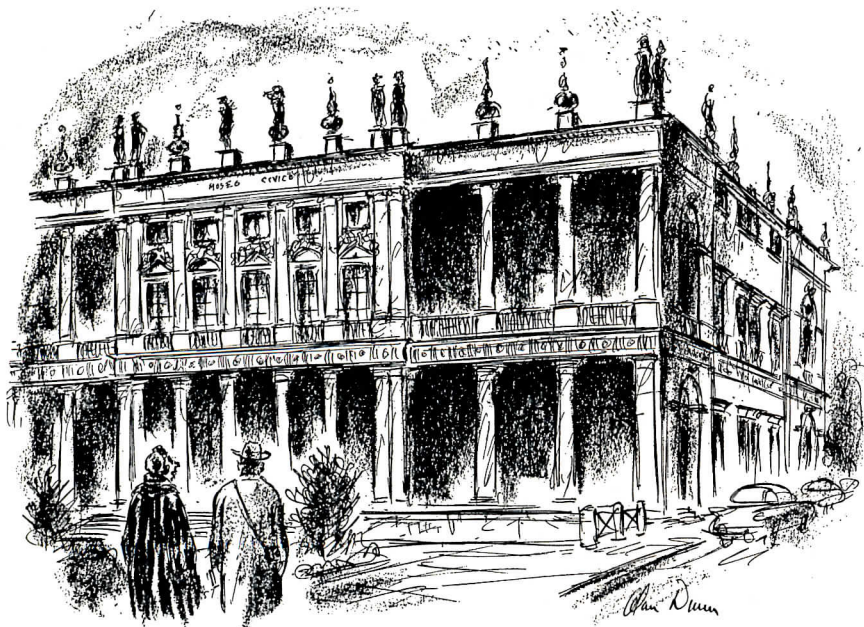

— Drawn for the RECORD by Alan Dunn

"You've got to hand it to Palladio — he never laid an egg"

For Interior Fire Protection in SCHOOLS and CHURCHES . . .

Of the many distinct
ALLENCO models,
these two are most
popular for installations
in this field.

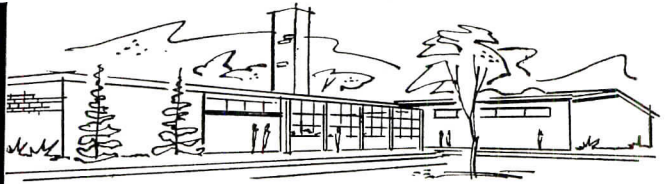

Allenco Fig. 285 is notably compact, contains one or two fire extinguishers and, if specified, tamperproof door.

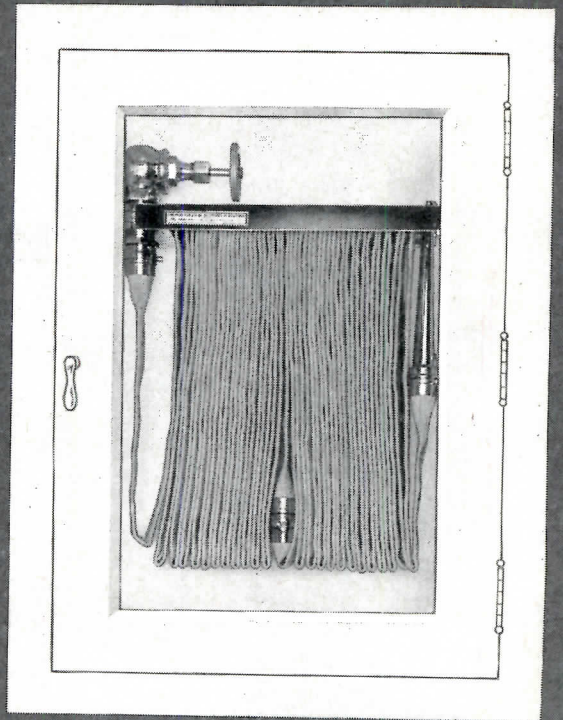

Allenco Fig. 262 is "custom-sized" to suit choice of 5 hose-lengths, 4 hose-sizes with plain or fog nozzles, with optional spanner and bracket, and space limitations of any application-point.

Cabinets of both units are available in several groups—Allenco Satin Finish Hollow Steel Door, Nella Sheet Steel

Door, Aluminum Doors, and other styles. Rigid and true-to-size, they go in faster . . . look better . . . serve perfectly.

Catalog 150
(A.I.A. file 29e2)
contains full details in
simplest form, including standard
quotable specifications.
Write for your copy now . . .



ALLENCO

Architects, Engineers and Contractors prefer

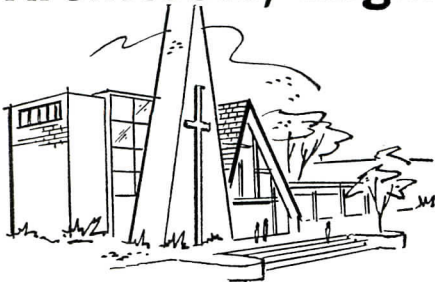

Here are a few recently completed installations:

Where

Springfield, Mass.
West Hartford, Conn.
Cincinnati, Ohio
Ann Arbor, Mich.
Portland, Ore.
Salem, Ore.
Salt Lake City, Utah
New Orleans, La.
Pullman, Wash.
Moscow, Idaho

Minneapolis, Minn.
St. Louis Park, Minn.
LaFayette, Ind.
Bloomington, Ind.

Fairview Park, Ohio

Gates Mills, Ohio

Pittsburgh, Pa.

What

Junior High School
Junior High School
Washington Park Elem. School
University of Mich. Library
Woodrow Wilson High School
South Salem High School
Latter-Day Saints Church
St. Martin's School
Women's Residence, W. S. C.
University of Idaho Library

Zion Lutheran Church
Cathedral High School
Purdue University Dorms
I. U. Medical Science Building

High School

St. Francis of Assisi Church

High School

Specifier

Maloney & Tessier
Nichols & Butterfield
A. M. Kinney
Albert Kahn Assoc.
Tom E. Taylor
Tom E. Taylor
Owner
James M. Todd & Assoc.
James B. Natkin
Whitehouse, Price,
DeNeff & Geeble
Thorsov & Cerney, Inc.
Louis C. Pinault,
Walter Scholer
Ammerman, Davis &
Stout
Fulton, Krinsky &
DeLaMotte
Horn & Rinehart, Archts.
P. B. Fleming, C. Engr.
Celli & Flinn

Installer

A. E. Stephens Co.
Wadhams & May Co.
B. A. Walterman Co.
Dunbar-Borton
A. G. Rushlight Co.
Vern Collins Flbg. Co.
Owner
Frank A. Dorsa
Senna Service, Inc.
Detweiler Bros.
Dean L. Witcher, Inc.
Roel Construction Co.
Freyn Bros.
Hayes Bros.
Gorman-Lavelle P & H
Gorman-Lavelle P & H
John Kennelly

Fieldman

Harold Jope
Harold Jope
Dick Disney
Russ Collins
Dick Finklea
Dick Finklea
Nic Nicodemus
Bob Barnes
Stan Schafer
Stan Schafer
Art Narverud
Art Narverud
Don Davisson
Don Davisson
Jerry Sullivan
Jerry Sullivan
Wm. Negle



Harold Jope



Dick Disney



Russ Collins



Dick Finklea



Nic Nicodemus



Bob Barnes



Stan Schafer



Art Narverud

* **ALLENCO** Fieldmen, operating from offices in 35 principal cities, offer prompt and useful help. Check "Fire Protection" in your classified phone directory or write for address of nearest office.

W. D. ALLEN MANUFACTURING CO.
Room 700 Allenco Bldg. • 566 W. Lake St. • Chicago 6

THE RECORD REPORTS

MEETINGS AND MISCELLANY

(Continued from page 21)

A.I.A. join in sponsoring the National Education Facilities Council, a professional organization for school planning research and service. *Package Deal* — The committee report recognized a “vacuum” into which the package dealer had moved, and proposed “that methods be devised by which architects, while performing ethically and in a professional manner, can themselves become ‘package dealers’”. The committee is aware of the fact that many architectural firms already are doing just that, with this significant difference from the commercial ‘package dealer’s’ practice — the architect continues to practice as a professional whose prime interest is the client’s welfare.” *Mandatory Standards* — the Board adopted an addition to Institute rulings on endorsements: “An architect shall not permit the use of a statement in advertising which could be construed as representing him as endorsing a product or method.” *Public Relations* — the Board approved the selection of Henry J. Kaufman and Associates of Washington, represented by Robert R. Denny, as public relations counsel to the Institute. *Institute Publications* — the Board approved a report by Joseph Watterson, the A.I.A.’s Director of Publications, recommending the merger of the Institute’s Journal and Bulletin, to take place in January 1958.

The Institute has called for entries in its annual National Honor Awards program. Open to all registered architects in the country, the program requires that the A.I.A. Committee on Honor Awards receive notification of intention to enter, with a \$10 registration fee, by January 7. Submissions are due March 1. For information: Committee on Honor Awards, The American Institute of Architects, 1735 New York Avenue, N.W., Washington 6, D. C.

Regional Meeting: Tacoma

In line with what begins to look like a trend in “thinking big” at conventions, the Northwest Region of the American Institute of Architects took “Architecture Unlimited” as its subject at its fifth regional conference, held at Tacoma in September. Notable among the speakers were keynoter William L. Pereira, A.I.A., of Los Angeles; Garrett Eckbo, landscape architect, Los Angeles; engineer Edgardo Contini of Los Angeles; and Philip Will Jr., A.I.A., Chicago. The theme seminar was led by John S. Detlie, A.I.A., of Seattle.

Regional Meeting: Yosemite

A joint meeting of the California-Nevada-Hawaii regional council of the American Institute of Architects and the California Council of Architects drew some 200 architects and 600 guests to Yosemite National Park for four days in October. Activities of the regional council, under director Donald Beach Kirby were confined to a single lunch-

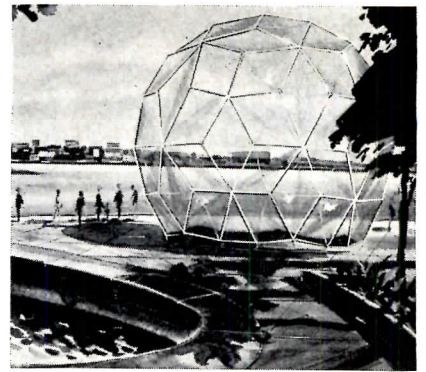

FOR THE BIRDS: the latest use devised for Bucky Fuller’s ubiquitous geodesic dome is a flight cage for Lakeside Park, Oakland, Cal. Designed by five architectural students at the University of California, the dome will be constructed of aluminum struts and mesh donated by Kaiser Aluminum, will shelter birds of the Pacific flightways

eon. The C.C.A., however, had a busy four days at a convention dedicated to “Planning for a Decade of Growth.” Supporting this theme were three of the major seminars on important building types — schools, housing and hospitals — led, respectively, by Archibald Shaw, Scarsdale, N. Y., superintendent of schools; Joseph Eichler, home builder and land developer; and Gordon Cumming, chief of Bureau of Hospitals, California Department of Public Health. A public relations seminar was conducted by Dwight Bentel, dean of the department of journalism at San Jose State College. Dr. Stephen C. Pepper, chairman of the department of philosophy at the University of California was the keynote speaker.

A Golden Anniversary

Members of the New York Society of Architects, an organization formed for “promoting and safeguarding the business and legislative interests of the architectural profession in the City and State of New York,” celebrated its 50th anniversary last month at its annual dinner meeting in New York City. At the dinner, Charles Rockwell Ellis, Syracuse architect, was presented with the Sidney L. Strauss Memorial Award, made yearly to “the person who has rendered outstanding service to the architectural profession.” The society also installed new officers at the dinner — Richard Roth, president; H. I. Feldman, vice president; John Joseph Carroll, secretary; and Nathan R. Ginsburg, treasurer.

(Continued on page 28)

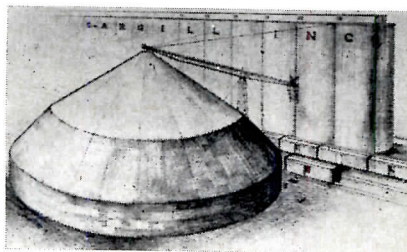
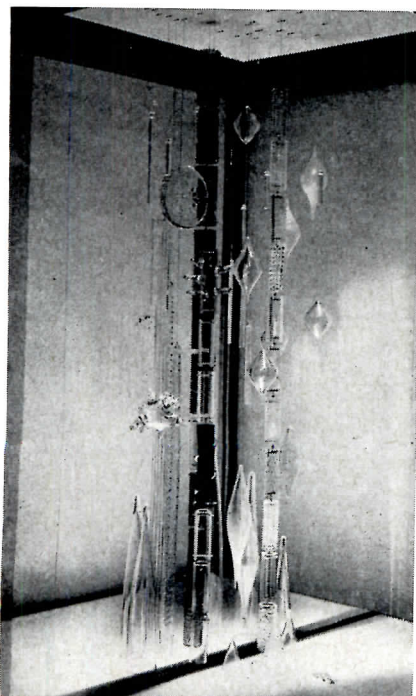

THE USES OF GLASS: glass sculpture (left) is part of “Adventure in Glass,” a down-to-earth exhibit now touring the country under the auspices of the American Federation of Arts and Orrefors Glasbruk of Sweden; it was designed to show possibilities of various colors and textures in glass. Above (and not part of glass exhibit): a new kind of grain elevator — a single-bin structure of concrete, steel and heavy-gage fiber glass — to be built near Toledo by Cargill Inc. (also its designers) has flexible roof supported by pneumatic pressure for loading, by the stored grain at other times



BRONZE

built

A tribute to modern structural design and production ingenuity

Contains over

1/2 MILLION LBS.

of **REVERE**

architectural bronze sheets
and extruded shapes

For centuries bronze has symbolized endurance. But it took the combined daring and imagination of Mies van der Rohe and Philip Johnson, with Kahn & Jacobs as associate architects, to take this most ancient of metals and shape it into a striking, modern, 38-story landmark . . . Seagram Building, 375 Park Avenue, N. Y. C.

With such a design, structural problems were bound to occur. But General Bronze Corporation, working with various suppliers, combined their skills and successfully met those challenges. Bolting the steel girders to eliminate the noise of riveting, for example, was a major innovation.

Revere contributed its share by furnishing all of the spandrel sheets of architectural bronze, 3 of the extruded shapes for the muntins and the jambs, and the architectural bronze sheet for the louvers used in the huge air conditioning cooling tower, a total of more than a half-million pounds. (Detailed captions opposite page.)

This is still another example of how Revere, since its founding over a century and a half ago by Paul Revere, has worked with architects, engineers, designers and contractors in creating many of the country's leading landmarks . . . and another good reason why it will pay you to put this accumulated knowledge to work for you by seeking Revere's collaboration on your next project.

REVERE COPPER AND BRASS INCORPORATED

Founded by Paul Revere in 1801

Executive Offices: 230 Park Avenue, New York 17, N. Y.

*Mills: Baltimore, Md.; Brooklyn, N.Y.;
Chicago, Clinton and Joliet, Ill.; Detroit,
Mich.; Los Angeles and Riverside, Calif.;
New Bedford, Mass.; Newport, Ark.;
Rome, N.Y. Sales Offices in Principal
Cities, Distributors Everywhere.*



Manufacturers of Revere Sheet, Roll and Strip Copper for roofs, gutters, downspouts and flashing . . . Revere Architectural Bronze extruded shapes and sheets for spandrels, muntins, mullions, jambs, louvers and decorative purposes . . . Revere Copper Water Tube for hot and cold water lines, plumbing lines, vent, waste and drainage lines, underground service and processing lines, radiant panel heating, air conditioning lines, and oil burner lines.

THE RECORD REPORTS

MEETINGS AND MISCELLANY

(Continued from page 24)

NEW STUDENT EXECUTIVE BOARD is pictured here in session at A.I.A. headquarters — (clockwise around the table) Edward Burkhead, Texas A. & M.; Leslie Moore, Rhode Island School of Design; Paul R. Neel, California State Polytechnic College; Don Roark, University of Colorado; George S. Crane, Texas Tech; M. Bird Woods, University of Virginia; Harry C. Wolf, Georgia Tech; Thymio Papayannis, M.I.T.; Robert S. Harris, Rice Institute



VOICE OF THE STUDENT: N.A.S.A. COMPLETES ITS FIRST YEAR

The National Association of Students of Architecture held its second annual forum in Washington, D. C., at the headquarters of its sponsor, the American Institute of Architects, November 19-21. The organization founded a year ago at a conference sponsored and financed by the A.I.A. had to assess its first year and take another look at its purposes and methods in the light of that experience. How the students felt about it, and what they did, are described in the following report prepared at the RECORD's request by the new president of the student organization, Thymio Papayannis of Massachusetts Institute of Technology

For three days, during the third week of November, the A.I.A. headquarters in Washington came alive with unusual activity. One hundred and four students from every corner of the United States were brought together to represent their 63 schools in the Second Annual Forum of the National Association of Students of Architecture (N.A.S.A.), sponsored by the American Institute of Architects.

The delegates did not only represent different schools. They represented a large variety of backgrounds and of educational policies. They represented all the range of modern concepts of architecture, from the extremes of defining it as a pure art or as a strictly engineering discipline to all the intermediate positions. They also represented every possible type of student organization: A.I.A. student chapters, informal groups in conjunction with planners and landscape architects, school committees associated with general student councils. So, the gathering in Washington was a faithful cross-section of the present currents in architectural education, student organization and our profession as viewed by the young people who will be practicing in a few years.

The purpose of the Forum was an important one. A year ago, the delegates to the first national meeting decided to form an organization of all the

students in this country. The present Forum had to decide, judging on 12 months' work, whether N.A.S.A. was a meaningful response to a definite need or whether it had no content; whether it should live or die. Moreover, if the Forum decided that N.A.S.A. should live, it had to take all the steps that would make the next year a more fruitful one.

The work to be accomplished was not easy. In the first day of the Forum local differences and personal disagreements ran high. However, from the very first meeting something wonderful started happening. People exchanged ideas. During the short intervals between meetings, at lunch, at the round-table discussion and the smoker of the first day the delegates came to contact with people from all corners of the country with one common passion — architecture. This common interest dominated all phases of the Forum. It was strengthened by the stimulating speeches of Mrs. Sibyl Moholy-Nagy and of Paul Rudolph, by the round-table discussion with John Knox Shear as the moderator, by the contribution of the A.I.A. Headquarters Staff and many of its members. So, by the end of the second day the character of the Forum changed. It was no more a place for airing minor differences created by local situations, but

a coherent group of people with a strong sense of responsibility and with one major urge: contributing even while being students to the heavy task of creating a better environment for people.

The results of the Forum were really encouraging. First, it was decided unanimously that N.A.S.A., as the organization which represents *all* the students of architecture in the U. S., is a meaningful entity and should live. It was decided that N.A.S.A. does not duplicate any existing organization, because it does not operate on the local level, it does not have local chapters or individual members. It operates on the national and regional levels and its members are the whole student bodies of the architectural schools. It was decided that N.A.S.A. should continue to work very closely with the A.I.A., who sponsored it from the first, and without whose help the N.A.S.A. would not have been able to stand on its own feet today.

Second, the constitution was voted unanimously. This was an important step in clarifying and setting in a definite form the purpose and functioning of the N.A.S.A. This being determined, the N.A.S.A. is free during the coming year to concentrate on its work unhampered by organizational difficulties.

The Forum also elected its new offi-

(Continued on page 372)

become one...

• SPARTAN

ROMANY



SPARTAN

*Member of Tile Council of America
and The Producers' Council, Inc.*

UNITED STATES CERAMIC TILE COMPANY • THE SPARTA CERAMIC COMPANY • CANTON 2, OHIO

"SENIOR CITIZENS": THE FEDERAL SPOTLIGHT FINDS THEM

The needs and problems of the aging have reached the status of a "hot topic" in Washington. The subject is getting attention in nearly every department of government; and there are several important programs under way. The official Federal Council on the Aging, established last April by the President as an inter-agency coordinating group, includes representatives of 13 departments and agencies (see list), nearly all of them of Assistant Secretary status or the equivalent, though none of Cabinet rank until last month, when Marion B. Folsom, Secretary of Health, Education and Welfare, became the new chairman. In Mr. Folsom's own department, a "Special Staff on the Aging" within the Secretary's office was formalized with the appointment in late October of William C. Fitch as its director; and the Public Health Service, which has its own special Assistant on Aging, Dr. John D. Porterfield, announced on October 30 the establishment of a Center for Aging Research in the National Institutes of Health. The Housing and Home Finance Agency on December 9 announced the appointment, as provided by the Housing Act of 1956, of an overall Advisory Committee on Housing for the Elderly (and scheduled the committee's first meeting for December 14); the Federal Housing Administration, presented by the 1956 housing act with amendments to its rental housing program (Section 207) providing mortgage insurance for housing for the elderly, on November 8 had issued its "Property Requirements for Housing for the Elderly under Section 207." And FHA had a new Special Assistant on Aging—Arthur W. Sherwood.

The opening of Congress this month can only be expected to provide another arena of intensive cultivation of the same territory: as one official said last month, "In this area, our problem with the Congress is not how to get what we want, but how to keep them from giving us more than we know what to do with at present."

This statement also gives a clue to a point worth noting — that among officials closely connected with Federal activities in the field, there seems so far no disposition to be doctrinaire about solutions; at the moment they are occupied with identifying the problems.

Their broad objective has been defined in these words of President Eisenhower: "In considering the changed circumstances presented by the lengthening life span, we must recognize older persons as individuals — not a class — and their wide differences in needs, desires and capacities. The great majority of older persons are capable of continuing their self-sufficiency and usefulness to the community if given the opportunity. Our task is to help in assuring that these opportunities are provided."

The appointment of Secretary Folsom as chairman of the Federal Council on Aging was significant as a government move demonstrating the importance attached to Federal matters concerning the elderly. The choice of a Cabinet member to head the group focuses new national attention on a long-standing problem — how to provide all aspects of a better life for those in their declining years.

The special interest of architects is obvious. One of the points in President Eisenhower's program, outlined last spring just before he established the Council, aimed at stimulating the construction of housing and the provision of living arrangements suited to the needs and preferences of older people. Since then Congress has considered a broad range of benefits for the elderly and amended the National Housing Act to liberalize mortgage insurance. Research is becoming an increasingly important part of the overall program, and during the past two years more emphasis has been placed on the construction of nursing homes through changes in the Hill-Burton hospital construction law.

All this is part of the growing awareness in government circles of the special problems besetting older persons in the modern economy and the need for bringing the best Federal talent to bear on the working out of solutions. To this end, a Committee on Aging was set up in the Federal Security Agency (now a constituent of the Department of Health, Education and Welfare) as early as January 1951, two years after the first decisions to stimulate more activity in this field had been made at agency level. The formation of the 12-member committee followed a National Conference on the Aging attended by some 8000 persons in August of 1950. This

(Continued on page 360)

FEDERAL COUNCIL ON AGING

- Department of Health, Education and Welfare — Secretary Marion B. Folsom (Chairman)
- Department of the Treasury — Dan Throop Smith, Special Assistant to the Secretary
- Department of the Interior — Newell B. Terry, Director of Personnel
- Department of Agriculture — Paul V. Kepner, Deputy Administrator, Extension Service
- Department of Commerce — George T. Moore, Assistant Secretary
- Department of Labor — Rocco Siciliano, Assistant Secretary
- Office of Defense Mobilization — Brig.-Gen. Carlton S. Dargusch, Assistant Director
- U. S. Civil Service Commission — John W. Macy Jr., Executive Director
- Veterans Administration — Dr. Irvin J. Cohen, Director of Hospitals and Clinics
- Housing and Home Finance Agency — Carter McFarland, Acting Assistant Administrator
- Small Business Administration — Robert H. Montgomery, Deputy Administrator
- National Science Foundation — Dr. John T. Wilson, Assistant Director
- Railroad Retirement Board — Walter Matcheck, Director of Research
- Secretary of the Council — Louis H. Ravin

ADVISORY COMMITTEE ON HOUSING FOR THE ELDERLY (HHFA)

- Theodore W. Berenson, Boston — real estate and building
- Ernest J. Bohn, Cleveland — director of the Cleveland Housing Authority, member of the President's Advisory Committee on Housing Policies and Programs
- Curtis F. Bryan, Tulsa — oil producer, banker
- Gardner Cowles, New York — president of "Des Moines Register and Tribune," Cowles Magazines ("Look" publisher)
- Charles Delmar, Washington, D. C. — president and director, Lincoln Service Corporation
- Dr. Wilma Donahue, Ann Arbor, Mich. — chairman, Division of Gerontology, University of Michigan
- Edna Basten Donald, Grand Island, Neb. — active in women's organizations
- Richard J. Gray, Washington, D. C. — president, Building and Construction Trades Department, AFL-CIO; member of the President's Advisory Committee on Housing
- Robert F. Hastings, A.I.A., Detroit — vice president, Smith, Hinchman and Grylls, Inc., architects and engineers
- Harry Held, New York — vice president, Bowery Savings Bank
- Samuel Hopkins, Baltimore — insurance and finance executive
- Morris Kanfer, Washington, D. C. — attorney
- William E. Murray, Loisa, Va. — real estate and building
- Miss Ollie Randall, New York — vice chairman, Committee on the Aging, National Social Welfare Assembly
- Thomas E. Shroyer, Washington, D. C. — member of law firm of Poole, Shroyer and Denbo; former Counsel to the Senate Committee on Labor and Public Welfare
- Earl W. Smith, El Cerrito, Cal. — home builder and immediate past president of the National Association of Home Builders
- Prof. Walter K. Vivrett, A.I.A., Minneapolis — architect and member of faculty at University of Minnesota; has served as consultant to Federal Housing Administration in this field of housing for the aging
- Prof. Irving Webber, Gainesville, Fla. — chairman of the Institute of Gerontology, University of Florida

...used in this school "planned for effective learning"

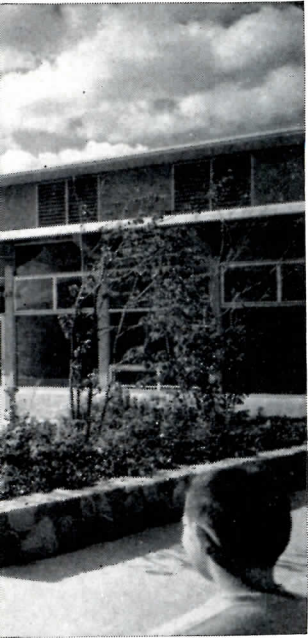

Among its many noteworthy features the Abraham Lincoln Junior High School has *FLEXIBILITY*. . . to permit altering classroom size to accommodate future curriculum changes. Classrooms have non-load-bearing partitions which can be relocated. Heating and ventilating is supplied from prefabricated acoustical radiant ceiling panels which can be rearranged to permit future changes.

Versatility of Powers Temperature Control is demonstrated in this outstanding school and the natatorium shown below.

The heating and ventilating system is divided into six zones depending on function of each area. The Powers control system permits normal daytime operation of any zone or zones while the balance of the building remains on economical night control.

Individual Room Control—Each room is equipped with a Powers Day-Night thermostat which modulates a Powers *packless* valve on the ceiling radiant heating coil. A Powers *MASTROL* system regulates the temperature of the forced hot water supplied to the ceiling coils. The classroom ceilings consist of perforated snap-on metal pans suspended from radiant heat coils above which a glass fiber blanket

provides insulation and acoustical absorption. The space between is an air plenum from which ventilating air is forced through the ceiling perforations into the classrooms.

Powers PACKLESS Valves a Must—They prevent leakage of water on ceiling and eliminate packing maintenance. Because they have no packing nut or gland to be tightened, oiled or adjusted, there is no binding of valve stem and they give better control.

Ventilation is regulated by Powers controlled fan units located throughout the building.

If You Are Planning a New School or remodeling an old one, ask your architect or engineer to include a Powers Quality system of temperature control. You will help insure utmost comfort and lowest upkeep cost.

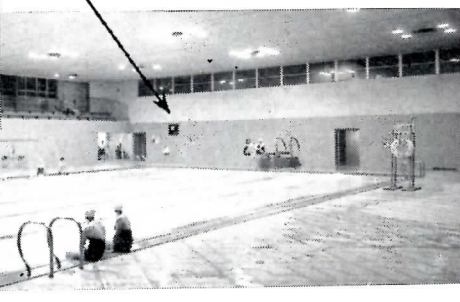
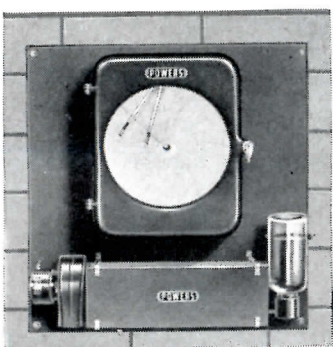
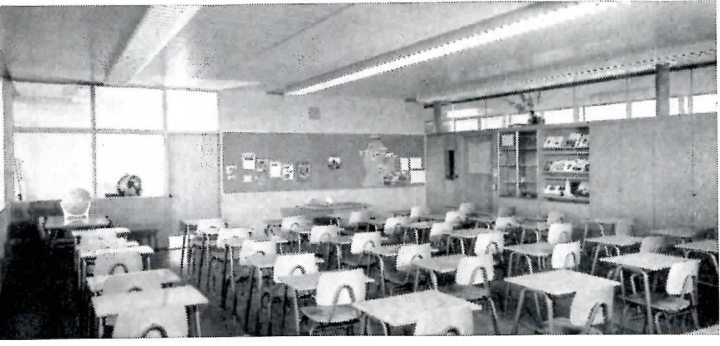
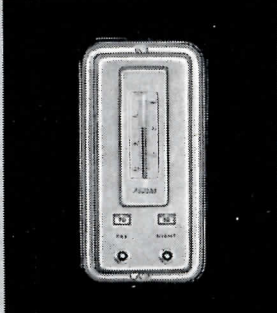
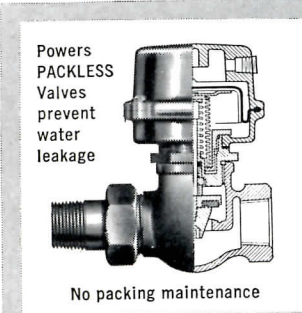

For further information contact our nearest office

THE POWERS REGULATOR COMPANY
 SKOKIE, ILLINOIS | Offices in Chief Cities in U.S.A., Canada and Mexico
 65 Years of Automatic Temperature and Humidity Control



Unique Indoor-Outdoor Pool—was built by the City of Wyandotte adjacent to the Lincoln School. Both share its cost and year 'round use, resulting in big savings. Note the large sliding glass doors opening in summer to outdoor sundeck. Heating and ventilating and pool water temperatures are thermostatically regulated by a **POWERS CONTROL SYSTEM**.

GREEN LIGHT GIVEN MONTREAL'S \$125 MILLION "CITY WITHIN A CITY" PROJECT

Papers have been signed to create a vast commercial plaza in downtown Montreal, along the lines of New York's Rockefeller Center. The project will be called Place Ville-Marie, after the name given Montreal by its first French settlers.

The agreement is between Canadian National Railways, which owns the land, and Webb & Knapp (Canada) Ltd., which will lease it.

First Step: Master Plan

First step is the preparation by Webb & Knapp of a master plan for the C.N.R.'s 23 acres of choice real estate surrounding Central Station. At least \$250,000 is to be spent on this task, which is to be completed to the satisfaction of the government-owned railroad's board of directors within six months.

A modest estimate of the entire development cost is \$125 million.

What Buildings?

Central Station, the International Aviation Building and the still incomplete Queen Elizabeth Hotel occupy part of the land and will be incorporated into the Webb & Knapp scheme. All of these structures were designed by the C.N.R.'s architectural staff.

Also to be considered is the new Terminal Center Building, the first privately owned venture in the station group. Architects Greenspoon, Freedlander & Dunne designed it to match the International Aviation Building next door.

First Project: "Monumental"

After approval of Webb & Knapp's master plan, the realty firm will be permitted to lease an initial 4.4 acres of the total 23, for a period of up to 99 years.

Development of the 4.4 acres, which is the area north of Dorchester Street bounded by Cathcart, Mansfield and University Streets, is not to take more than five years.

Webb & Knapp has deposited \$500,-

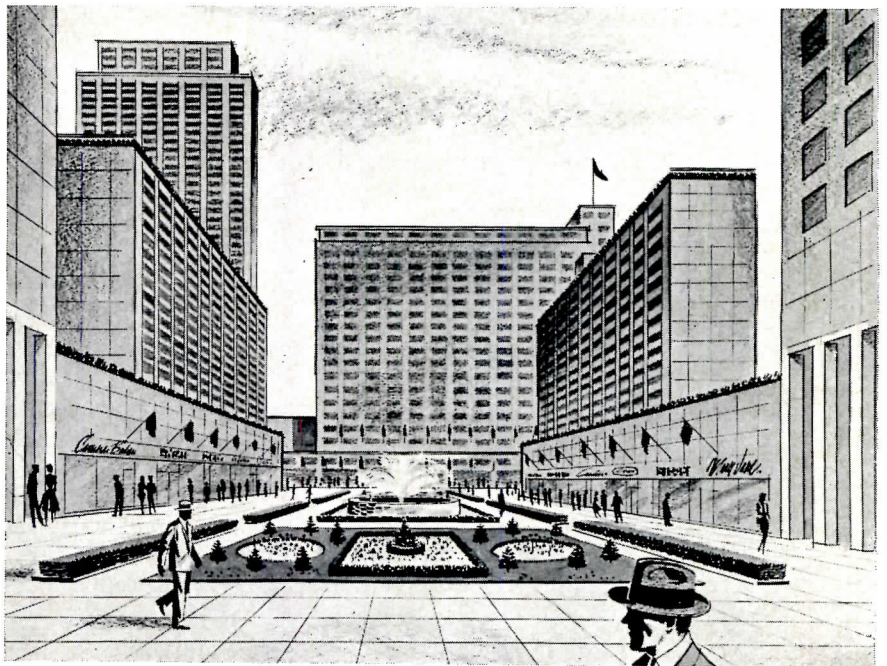

PLACE VILLE-MARIE in an "artist's sketch" (supplied by C.N.R.) showing how it might look on completion. Fountain, gardens and walk will make a place of promenade of a block-long Montreal area from Dorchester to Cathcart streets (at the foot of McGill College Avenue). Here the view is from Cathcart Street with the C.N.R.'s Queen Elizabeth Hotel, now under construction, in center background. The other buildings shown are only "artist's concept" of future development and not programmed structures

000 with the C.N.R. as evidence of good faith in discharging its obligations. Announcement has already been made by the realty firm of a \$25 million bond issue for initial capitalization of the project.

At a press conference called by Mayor Jean Drapeau of Montreal, William Zeckendorf, president of Webb & Knapp, stated that the first office building contemplated was a "monumental" as opposed to a "speculative" structure. No architect has been named as yet.

C.N.R. Wants Other Proposals

The portion of C.N.R. property not to be covered by the Webb & Knapp lease lies south of Dorchester Street. Donald Gordon, president of the railroad, said

Here the artist's sketch shows view from west and cross-section of three-level parking scheme envisioned below the plaza. As now proposed, it would accommodate 450 cars; there would also be a walkway for pedestrian access from Cathcart Street to railway station and hotel. Auto traffic to station would move via lowest level, second level would take vehicles to hotel's lower-level entrance, top would be parking only

at the conference that proposals for development of this area would be welcomed from any "interested parties willing to fit their plans to the character of the master plan." He emphasized that Webb & Knapp will have no option or preference with respect to this land but will have equality of opportunity in submitting proposals for development.

More Plazas to Come?

Insofar as Montreal is concerned, the start made on Place Ville-Marie is expected to reverse the trend towards decentralization as marked in recent years. It is inevitable that the whole downtown section will benefit, a rejuvenation which may be echoed in other cities as well. At the press conference, Mr. Zeckendorf disclosed that negotiations are being conducted regarding similar projects "from coast to coast," and specifically mentioned Toronto, Vancouver, and "two other cities." He declined to say whether the latter were in the Maritimes.

Webb & Knapp (Canada) Ltd. is a subsidiary of the New York firm bearing the same name. Twelve of its 18 directors are Canadians.

(Continued on page 40)

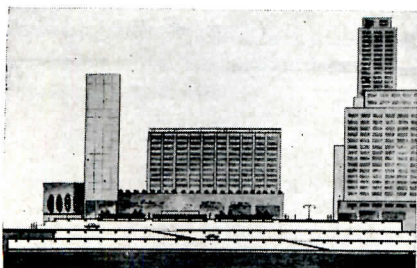

world's first bronze building

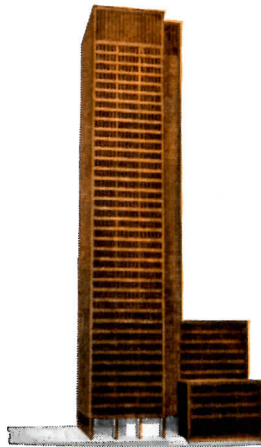

HOUSE OF SEAGRAM uses largest bronze shapes ever extruded commercially

The architects had a dream: to give New York's Park Avenue the world's first bronze skyscraper. And Chase engineers helped make it real. Constructing the Seagram Building "Curtain Wall" entailed fabrication of straight, true I lengths larger in diameter than ever considered practical. Chase, working with the architects, the General Bronze Corporation and other mills, played an important part in opening new horizons in design.

WHY BRONZE? Mies van der Rohe and Philip Johnson chose bronze for its nobility, beauty of color and structural flexibility. Moreover, the copper alloy called "Architectural Bronze" has mellow-

ing qualities that will give the building a rich brown *patina* as it ages. Practically speaking, bronze requires a bare minimum of maintenance. But first came construction problems.

WHY CHASE? Technical "know-how" plus the most modern facilities eminently qualified Chase for its share of the job. Many of the specially-designed extrusions that make up the bronze facade are historical "firsts." Chase made valuable contributions to the engineering and modification of these shapes—as well as to the production of them. Perhaps you, too, have an architectural dream... *Chase is at your service.*



STRAIGHTENING PROCESS involves drawing shape through a second die.

PAINSTAKING HAND WORK assures that dimensions are micrometer-perfect.

QUALITY CHECK is made at factory of four shapes produced by Chase.

CAREFUL PACKAGING makes sure shapes reach building in flawless condition.

Chase

BRASS & COPPER CO.

Subsidiary of KENNECOTT COPPER CORPORATION • WATERBURY 20, CONNECTICUT

The Nation's Headquarters for Brass, Copper and Stainless Steel

Atlanta Baltimore Boston Charlotte Chicago Cincinnati Cleveland Dallas Denver Detroit Grand Rapids Houston Indianapolis Kansas City, Mo. Los Angeles Milwaukee Minneapolis Newark New Orleans New York Philadelphia Pittsburgh Providence Rochester St. Louis San Francisco Seattle Waterbury

THE RECORD REPORTS

NEWS FROM CANADA

(Continued from page 36)

1957 FORECASTS ALL IMPLY BRIGHT CONSTRUCTION VISTA

In Canada, as in U. S., expenditures on construction in 1957 are expected to reach a new high, although a further leveling-off in house building is likely to occur.

Canada's rate of economic expansion,

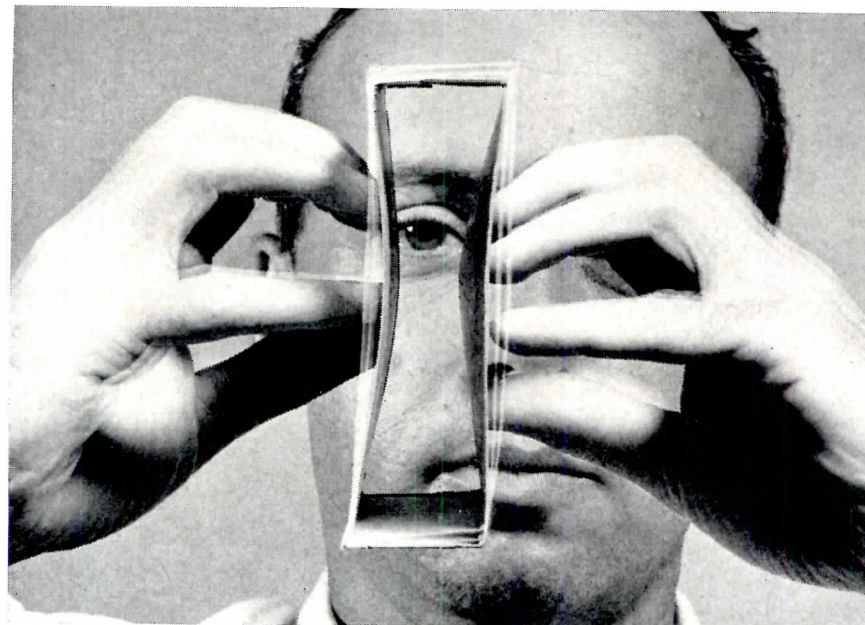

How to build a building with walls that...MOVE!

"Take a cereal box, press against its sides . . ."

That's how a Crown Iron Works engineer might describe how his firm licked a tough design problem on American Hardware Mutual's new Minneapolis home office.

The cereal box represents the thin, hollow, stainless-steel vertical ribs that support the glass wall. Normally, Minnesota's extreme temperature variations would make these panels expand and contract so much they'd be tough to hold weather tight.

Crown Engineers couldn't do anything about the temperature, so—with the architects—they devised a special elastic mounting for the panels. Now, when the walls contract or expand, a built-in spring-like action absorbs the movement. Result: a permanent, continuous wall as close to leakproof as any yet designed.

Next time you have a fabricating problem—any kind—give the men at Crown a call.

Architect: Thorshov & Cerny . . . Contractor: Johnson, Drake & Piper, Minneapolis



CROWN IRON WORKS CO.

1229 Tyler Street N.E., Minneapolis 13, Minnesota, STERLING 9-3556

THE MINDS AND METALS TO SOLVE YOUR PROBLEMS

OLYMPIC STADIUM? — plans for \$6 million stadium which would be extension to existing grandstand and could accommodate the Olympics have been submitted by Canadian National Exhibition authorities to the Toronto City Council. Marani and Morris are the architects, as they were of the original grandstand, which won an Olympic prize for sports buildings just after the war. Structure would be reinforced concrete up through first seating deck, steel frame above with reinforced concrete second deck. Exterior walls would be brick and aluminum. Baseball, football and soccer accommodations are proposed

only three per cent per annum pre-war, began to increase rapidly after World War II. It was 10 per cent in 1955-56.

Construction represents nearly one fifth of the country's gross national product. In forecasts made to date, public and private economists appear to agree that more prosperity is on the way. Only problem is that there may not be enough men, money and materials to go round.

House building is not expected to share in the general advance. Factors blamed are a shrinking market due to rising prices, lower rate of family formation, and failure of the government to raise the interest rate on NHA-insured mortgages. But as one expert puts it, "Until Canada's limited resources catch up with her backlog of growth, it is probably just as well that part of those resources should be diverted away from housing and into production of things more essential for the future."

GOVERNOR GENERAL OFFERS A CHALLENGE TO PLANNERS

About 400 delegates and guests at the annual conference of the Community Planning Association, held in Ottawa, October 28-31, heard Governor General

(Continued on page 42)



Architectural-grade Weldwood Walnut Plywood at First Federal Savings & Loan Assoc., Madison, Wisc. Architect: Lewis A. Siberz.

The trend is to warm, friendly interiors—
Weldwood paneling makes the job easy

Weldwood hardwood paneling beautifies as nothing else can ... and it helps create a friendly atmosphere for comfortable customer relations.

The cost is moderate ... and installation is easy.

Cold, austere business interiors are fast becoming things of the past. Banks, restaurants, stores, offices and others want a warm, friendly atmosphere that makes their customers feel at home. They find they can get this effect best, and most easily, with fine hardwood paneling. But that's only part of the story. Fine hardwood paneling is one of our richest, most beautiful decorating materials.

An installation of Weldwood hardwood paneling is the surest way to give your clients the ideal combination of warmth and beauty. Weldwood offers a wide choice of woods. For regular jobs

choose from walnut, mahogany, Korina®, Samara*, oak, or cherry.

For very special jobs, where you want to achieve unique one-of-a-kind beauty, use custom, blueprint-matched Weldwood paneling. Stock panels are sequence numbered to assure a perfectly matched installation. Figured walnut, mahogany and oak, Brazilian rosewood, Korina, teak and American cherry are carried in stock.

Contact your Weldwood Architect's Service Representative. He'll be happy to help you choose the right woods for your job, from our large and varied collection.

*Trademark



Weldwood®

Wood Paneling

A product of

UNITED STATES PLYWOOD CORPORATION

Weldwood—The Best Known Name in Plywood

**United States Plywood Corporation
 Weldwood Building, 55 West 44th St., New York 36, N.Y.**

Please send me a free copy of your new 28-page booklet "Weldwood Functional Beauty for Business and Institutional Interiors."

AR1-57

NAME

FIRM

ADDRESS

CITY STATE

THE RECORD REPORTS

NEWS FROM CANADA

(Continued from page 40)

Massey charge that Canadians have not fully responded to the challenges offered by nature in the building of their cities.

Mr. Massey, who is an honorary member of the Royal Architectural Institute of Canada, told the C.P.A.C. that too many Canadian towns are a scene of man-made confusion because they have been given no logical shape.

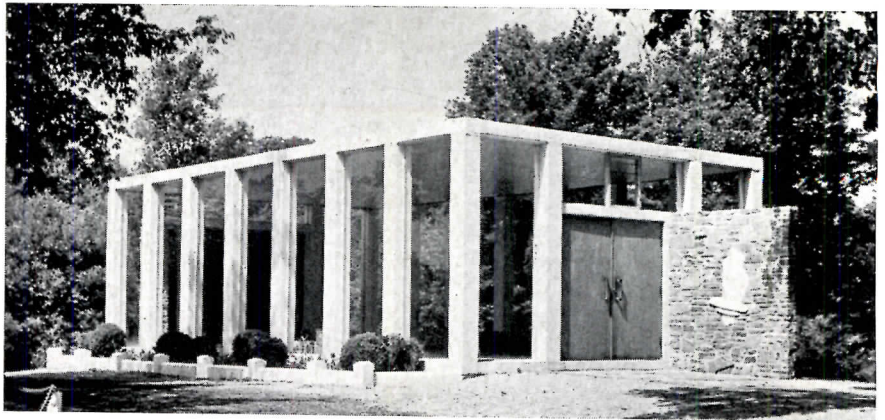

MAITLAND cemetery chapel, in Goderich, Ont.; Philip Carter Johnson is the architect

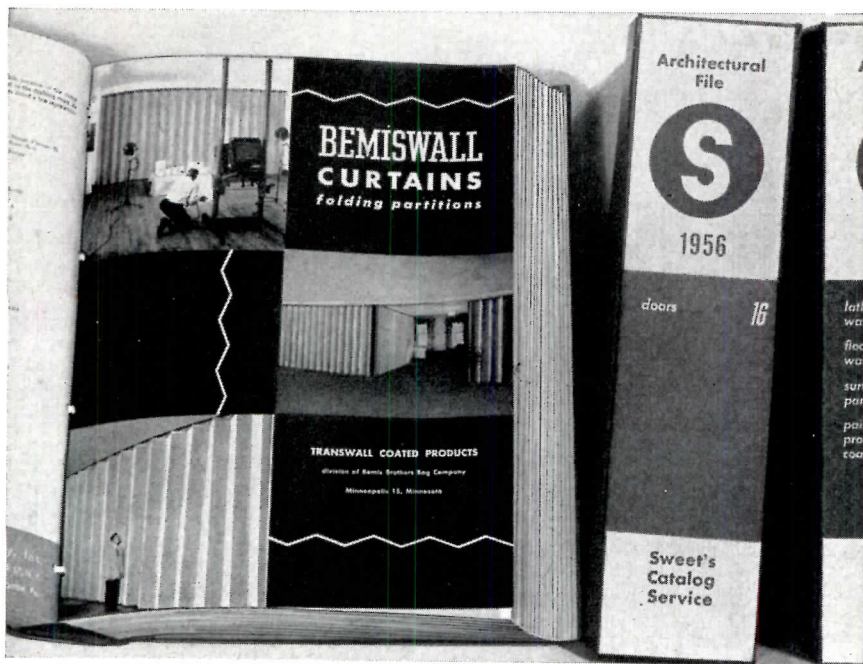

We'll see you in Sweet's Architectural File . . .

And there you'll see why you should specify **BEMISWALL Low-cost Folding Walls and Doors.**

You'll understand, when you see BEMISWALL's ingeniously simple design, why it can be so economically priced and still offer such high value in

**Fire Resistance • Sound Control • Ease of Operation
Long Life • Freedom from Damage • Ease of Installation
Light Weight • Compactness • Adaptability**

For complete specification data, see Section **16a** of the 1957 Sweet's Architectural File, or send the coupon for your free personal copy of the

BEMISWALL FOLDER

TRANSWALL COATED PRODUCTS
Bemis Bro. Bag Co., 610 4th St. S., Minneapolis 15, Minn.
Please send me a copy of Bemiswall Specification Data, as reproduced in Sweet's Architectural File.

Name _____

Company _____

Address _____

City _____ Zone _____ State _____

TRANSWALL COATED PRODUCTS • Bemis Bro. Bag Co.

While communities once were built around a cathedral, fortress, university or other natural focal point, too many Canadian centers have been improvised or assembled as a result of forces outside themselves, he said. The towns just grew because they were on railroad or river junctions.

Mr. Massey reminded his audience that Canadian homes once had a kind of harmony with the countryside because they were built with materials at hand, and remarked that harmony has largely been lost in the years of rapid growth. But he believes that the principle of town planning is being accepted almost everywhere in Canada "and we are becoming more aware of the need to make up for past neglect."

The Association's sessions included a panel discussion on the National Capital Plan, featuring talks by D. L. McDonald, B. L. Arch., M.T.P.I.C., director of Planning for the Federal District Commission, and A. K. Hay, District Commission general manager. There were also addresses by Carl Feiss of Washington, D. C. and W. W. Scott.

ARMORY BUILDING PROGRAM IS POSTPONED FOR NOW

The projected armory program is to be postponed. A committee of senior officers at Department of Defense headquarters has prepared a list of badly needed drill halls, but the Government's wish to take the lead in curtailing all but non-essential construction has put off any request to Parliament.

Building of armories, used largely by militia units, has been neglected in Canada for the past 10 years. Defense construction in that period was largely concentrated on Army camps and R.C.A.F. stations needed first for Korean and then NATO commitments.

(Continued on page 44)

Wind-o-line Radiation makes the difference!

Indoor thermal comfort is related not only to room air temperature, but to the temperature of the surrounding surfaces as well.

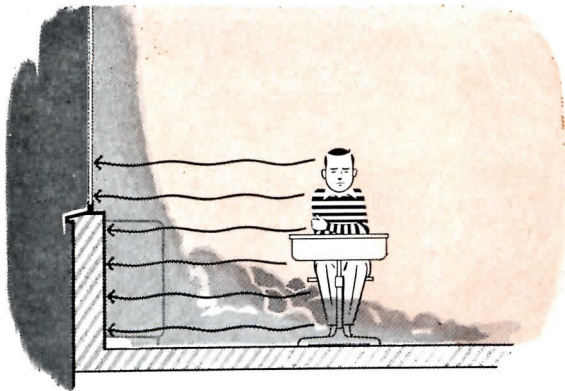

Without Wind-o-line Protection, pupils seated near large windows are uncomfortable on cold days because they lose too much body heat to cold surfaces and are exposed to chilling downdrafts—even when the room air temperature is right.

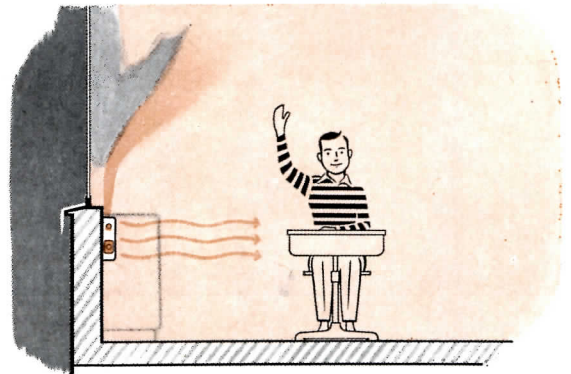

With Wind-o-line Protection, windows, outside walls and floor are warmed to offset the loss of body heat, and a rising blanket of heated air warms and diverts the chilling downdraft. Now all students sit in a protected learning environment.

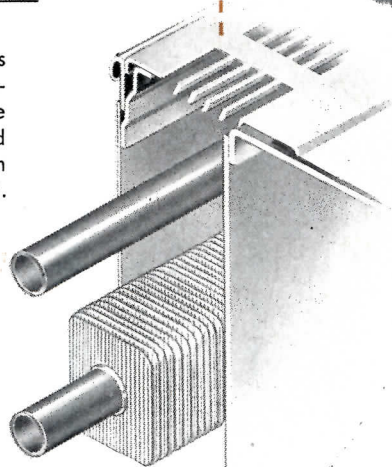

Wind-o-line Radiation installed all along the cold window wall is the bonus feature in the Nesbitt system of heating, cooling and ventilating. Wind-o-line may be concealed by wall-hung enclosures or Nesbitt storage cabinets.

The Nesbitt Series Hot Water Wind-o-line System provides the protected learning environment at proven lower costs.

You save through: elimination of costly pipe trenches, runouts and pipe covering; smaller pipes and pumps; factory installed piping in the unit ventilator.

The Added Protection of Wind-o-line Radiation Increases the Yield of Good Teaching

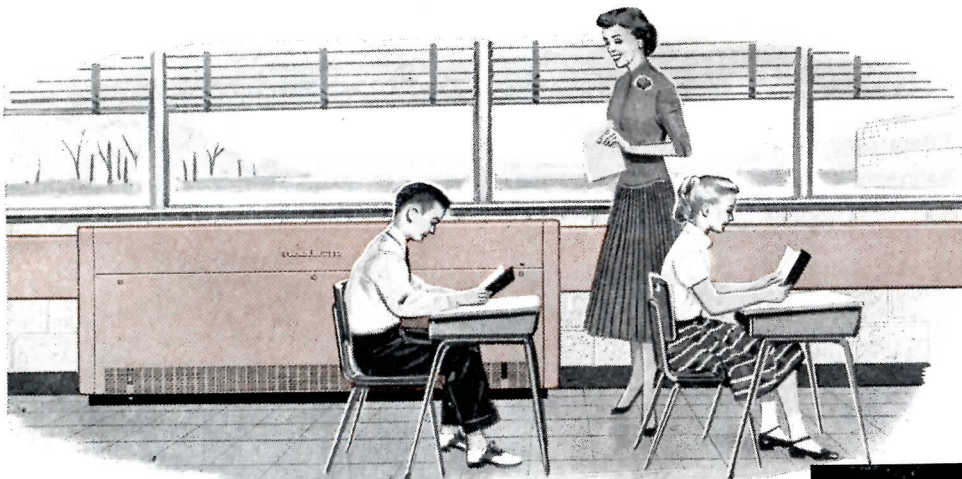

Send today for your copy of Publication 101. It tells how you may obtain more learning per school dollar.

CLASSROOM HEATING AND VENTILATING EQUIPMENT BY

Nesbitt

Made and sold by John J. Nesbitt, Inc., Philadelphia 36, Pa. Sold also by American Blower Corporation and American-Standard Products (Canada) Ltd.

PROBLEM: obtaining an overhead door that will blend with a modern-looking fire station and also afford smooth operation, fast action!

RAYNOR OVERHEAD DOORS

solve your most difficult

Installation Problems

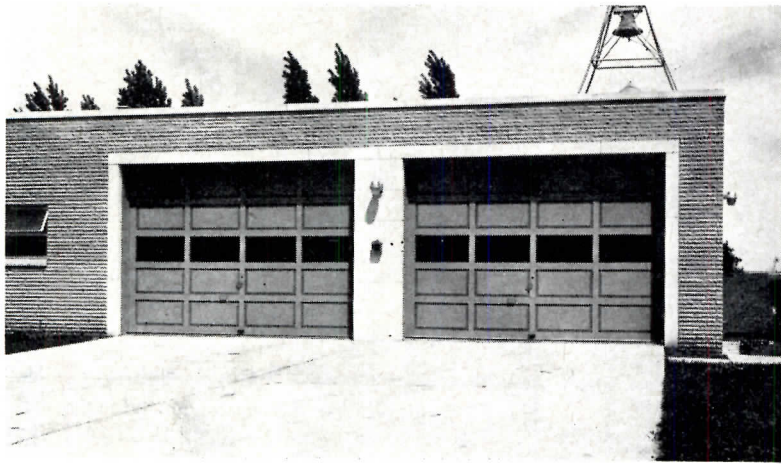

RAYNOR **INSTANT LIFT** Design for Quick Manual Operation

Whatever your problem, Raynor's engineering staff is always ready to advise you on special equipment and design. For example, the problem above was easily solved by supplying an architecturally-correct commercial overhead door PLUS Raynor's quick-release mechanism that permitted an easy switch to manual operation (a necessary precaution against power failure). Raynor's instant lift produces quick response when it's needed most.



Check your telephone directory for the Name of Your Nearest Representative or write to

RAYNOR MANUFACTURING CO.
Dept. AR-1 Dixon, Illinois

Builders of a complete line of wood sectional overhead doors

THE RECORD REPORTS NEWS FROM CANADA

(Continued from page 42)

NEWS NOTES

Council of the R.A.I.C. met in Toronto November 23-24 to discuss plans for the Institute's 50th anniversary assembly, to be held at the Chateau Laurier, Ottawa, May 29-June 1. . . .

Engineering registrations at Canadian universities have jumped 12.2 per cent in 1956-57, members of the Vancouver branch, Engineering Institute of Canada, were told recently by national president Vernon McKillop; there are 12,723 engineering students compared with last year's 11,341. . . . "Skillpower" is being lost to Canada by professional bars, the *Financial Post* suggested in a recent article. Reason claimed is that immigrants qualified in their own countries find the road to utilization of their talents barred by a maze of restrictions. . . .

Quebec Association of Architects holds its annual meeting February 1-3 at the Alpine Inn, St. Marguerite. . . .

Alberta Association of Architects announces election of Gordon B. McAdam as chairman of its Calgary Chapter for 1956-57. Other Calgary officers: William Milne, vice chairman; Joel Barrett, secretary; Jack Clayton, public relations officer; Jules Paivio, allied arts representative; Harry Williams, past chairman. . . . **Ontario Association of Architects** announces nine new members: Murray M. Brown, David E. Crinion, Roy P. Darke, Elmore L. Hankinson, E. C. Coleman Hicks, Arthur F. Peach, Wilfred B. S. Sorensen, Richard F. Lawton and George G. Walker.

Contracts Awarded: Comparative Figures*

(in \$ million)

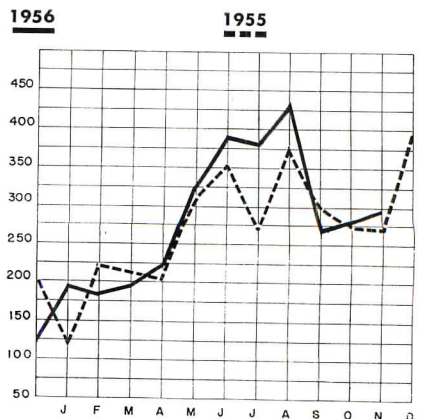

* Compiled by the Editor and staff of *The Building Reporter*, from information collected by Maclean Building Reports
(More news on page 48)

specified Building!



Here's an interior view showing a small part of the installation of Gold Seal Inlaid Linoleum. Actually, about 3½ acres of floor space are covered with this ⅛" burlap-backed "Veltone."

MORE than 148,000 square feet of Gold Seal Veltone® ⅛" Inlaid Linoleum has been specified and installed in the new Maine State Office Building at Augusta, Maine.

Originated by Gold Seal, "Veltone" provides an attractive, long-wearing, all-over decoration for use in all public buildings, schools, hospitals, offices, etc. Veltone's excellent resiliency provides quiet and comfort under foot. The unique design of this Inlaid Linoleum literally hides foot marks... it's exceptionally easy to clean and keep clean because of its density and surface smoothness. This ease of maintenance naturally reduces the expense of building service and upkeep. For those who prefer the modern textured look in Inlaid Linoleum, Gold Seal offers Sequin®—⅛" thick—with all the advantages of "Veltone."

Gold Seal Vinylbest* Tile and Gold Seal Asphalt Tile were also used in special areas such as the food and photo laboratories.

Specifications—Gold Seal Veltone: 6' wide yard goods, ⅛" gauge, burlap-backed. Install over suspended wood, or suspended concrete under-floors. Available in 8 colors—Pompeian Grey, Heather Tan, Spicewood, Bermuda Grey, Light Tan, Grey, Brown, Surf Green. Also made in standard gauge for residential use—in 9 colors.

Send for Free Technical Data Book—"Why Resilient Floors"—containing 36 pages of information to help you specify the correct resilient floor for any type of commercial, institutional or residential building. Address Architects' Service Department, Gold Seal Floors and Walls, Congoleum-Nairn Inc., Kearny, N. J.

PROVIDE YOUR CLIENTS WITH THE FINEST IN FLOORING — SPECIFY GOLD SEAL



FOR HOME... BUSINESS... INSTITUTIONS:

BY THE YARD AND TILES—Inlaid Linoleum • Nairon®
Plastics • Vinylbest* Tile • Cork Tile • Rubber Tile
Asphalt Tile

PRINTED FLOOR AND WALL COVERINGS—
Congoleum® and Congowall®
RUGS AND BROADLOOM—LoomWeve®

SATISFACTION GUARANTEED OR YOUR MONEY BACK

© 1957 CONGOLEUM - NAIRN INC., KEARNY, N. J.



FOR THE LOOK THAT'S YEARS AHEAD

Gold Seal®
FLOORS AND WALLS

*Trademark

10 ARCHITECTS NAMED IN CORREGIDOR COMPETITION

Five architectural firms selected in an invitation competition from among 43 participants and five additional firms "specially invited" by the Corregidor Bataan Memorial Commission will compete in the second and final phase of the national competition for a Pacific War Memorial to be placed on Corregidor Island (AR, Oct. 1956, page 48).

The first stage winners, announced last month by the Commission, were (the order is alphabetical only): Anshen and Allen, San Francisco; Katz, Waisman, Blumenkranz, Stein, Weber of New York; Naramore, Bain, Brady and Johanson, Seattle; Donald Powers Smith, San Francisco; Paul Thiry, Seattle.

Also announced were the invited finalists: Shepley, Bulfinch, Richardson and Abbott, Boston; Francis Keally and

Howard S. Patterson, New York; McKim, Mead and White, New York; Gardner A. Dailey, San Francisco; Gugler, Kimball and Husted, New York.

The final stage of the competition was to end in mid-April.

Commission Chairman Hon. Emmet O'Neal, former Ambassador to the Philippines, explained that the purpose of holding the competition in two stages was "twofold: first, to afford any interested architect an opportunity to display his ability and to have an equal chance with the other forty-three competitors of being selected one of five; and second, by inviting five firms of proven ability, to protect the interests of the government by ensuring that at least five firms of recognized talent would compete for the final fee of \$10,000."

As it turns out, "proven ability" can hardly be regarded as wanting among the firms selected by competition.

Members of the Jury of Award for the first-stage competitors were architects Pietro Belluschi, dean of the School of Architecture and Planning at Massachusetts Institute of Technology; William J. H. Hough of Philadelphia; and Frederick V. Murphy of Washington, D. C.; Vice Admiral William O. Hiltabidle (USN-ret) of Washington, D. C.; and sculptor Lee Lawrie of Easton, Md. The Jury will be expanded in the final stage to include two more architects, Arthur Brown Jr. of San Francisco, William Gehron of New York, and John W. Root of Chicago; Admiral of the Fleet Chester W. Nimitz; Gen. George C. Kenney (USAF-ret); Gen. Walter Kruger (USA-ret).

The Commission's release on the competition provided these comments of Dean Belluschi, "speaking for the Jury":

"The Jury was agreeably impressed by the general quality of the submissions and felt that there were many ideas capable of being developed into appropriate and dignified memorials. Although the sculptor member of the Jury felt that not a sufficient number of sculptures had been presented and hoped that more of them will be shown in the second stage, it was agreed that a few of the architectural designs had plastic qualities which could assume the spiritual and symbolic power of pure sculpture.

"At this first stage of the competition, the Jury did not feel it necessary to question too closely the kind of materials intended to be used in each entry

(Continued on page 346)

ACRES OF NATURAL LIGHT WITH



ANOTHER MARCO ACHIEVEMENT

One Hundred Twenty Six Marcolite Skylights, Nine Feet By Twenty Feet, Completely Preassembled, Creating The Finest In Modern Skylighting.

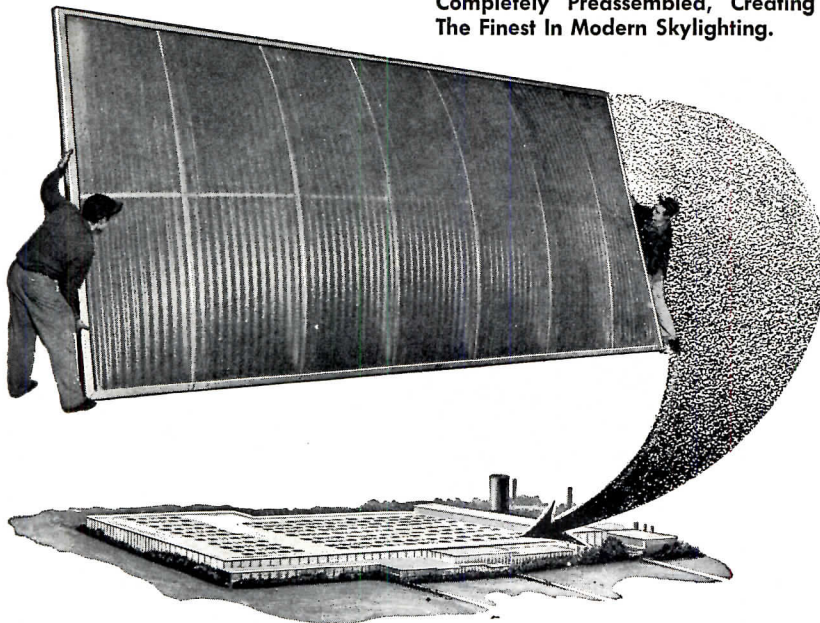

Owens-Corning Fiberglas Plant
Barrington, New Jersey

Bechtel Associates of New York
Architect & Engineer

THE MARCO COMPANY
45 GREENWOOD AVE., EAST ORANGE, N. J.

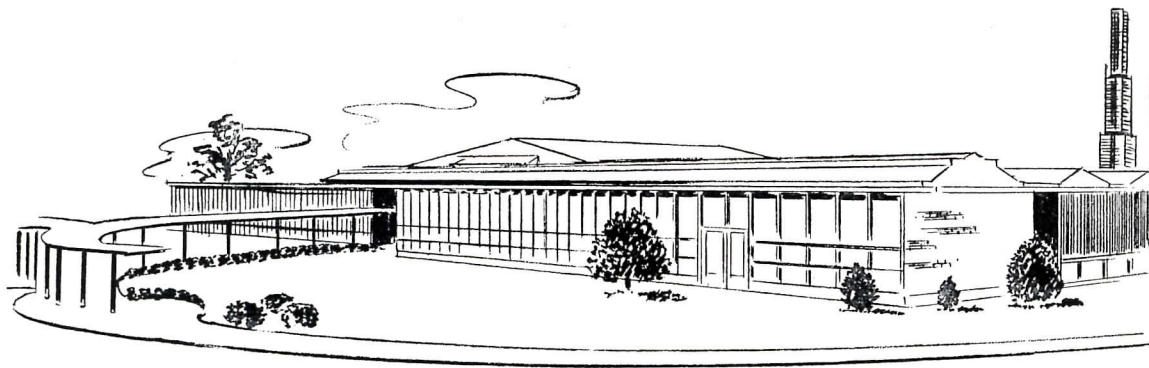

Benjamin Franklin High School, Newark, Ohio
 Architect: Joseph Baker & Associates
 General Contractor: Buckey Bros., Inc.
 Painting Contractor: Max Bowman
 P & L Products Used... *New* Lyt-all Flowing Flat;
 Vitralite Enamel; "61" Gymnasium Floor Finish.

**CRAFTSMANSHIP
 IN THE
 PACKAGE**



For generations it has been the privilege of Pratt & Lambert to work closely with leading architects, on every type of building and in every important city or town throughout the United States and Canada.

Out of this experience has come proficiency in serving architects *the way they like it* with prompt, complete, reliable information; with authoritative painting specifications; with color counsel that is

sound, distinctive and consistent with both form and function.

This service is available to you, without obligation of course. Please write your nearest Pratt & Lambert Architectural Service Department: 3301 38th Ave., Long Island City 1, N. Y.—326 West 26th St., Chicago, Ill.—75 Tonawanda St., Buffalo 7, N. Y. In Canada: 254 Courtwright St., Fort Erie, Ont.

P
R
A
T
T
&
L
A
M
B
E
R
T



THE RECORD REPORTS: CONSTRUCTION COST INDEXES

Labor and Materials

U. S. average 1926-1929=100

Presented by Clyde Shute, manager, Statistical and Research Division, F. W. Dodge Corp., from data compiled by E. H. Boeckh & Assocs., Inc.

NEW YORK

ATLANTA

Period	Residential		Apts., Hotels Office Bldgs. Brick and Concr.	Commercial and Factory Bldgs. Brick and Steel		Residential		Apts., Hotels Office Bldgs. Brick and Concr.	Commercial and Factory Bldgs. Brick and Steel	
	Brick	Frame		Brick	Frame	Brick	Frame		Brick	Frame
1930	127.0	126.7	124.1	128.0	123.6	82.1	80.9	84.5	86.1	83.6
1935	93.8	91.3	104.7	108.5	105.5	72.3	67.9	84.0	87.1	85.1
1939	123.5	122.4	130.7	133.4	130.1	86.3	83.1	95.1	97.4	94.7
1946	181.8	182.4	177.2	179.0	174.8	148.1	149.2	136.8	136.4	135.1
1947	219.3	222.0	207.6	207.5	203.8	180.4	184.0	158.1	157.1	158.0
1948	250.1	251.6	239.4	242.2	235.6	199.2	202.5	178.8	178.8	178.8
1949	243.7	240.8	242.8	246.4	240.0	189.3	189.9	180.6	180.8	177.5
1950	256.2	254.5	249.5	251.5	248.0	194.3	196.2	185.4	183.7	185.0
1951	273.2	271.3	263.7	265.2	262.2	212.8	214.6	204.2	202.8	205.0
1952	278.2	274.8	271.9	274.9	271.8	218.8	221.0	212.8	210.1	214.3
1953	281.3	277.2	281.0	286.0	282.0	223.3	224.6	221.3	221.8	223.0
1954	285.0	278.2	293.0	300.6	295.4	219.6	219.1	223.5	225.2	225.4
1955	293.1	286.0	300.0	308.3	302.4	225.3	225.1	229.0	231.5	231.8
July 1956	313.7	304.8	323.8	329.2	328.5	239.8	238.4	245.3	247.8	252.6
Aug. 1956	313.7	304.8	323.8	329.2	328.5	240.0	238.5	245.4	247.9	252.7
Oct. 1956	313.0	303.8	324.1	334.7	329.2	239.7	238.0	245.8	248.2	252.9
Oct. 1956	153.4	148.2	% increase over 1939			177.8	186.4	% increase over 1939		
			148.0	150.9	153.0			158.5	154.8	167.1

ST. LOUIS

SAN FRANCISCO

1930	108.9	108.3	112.4	115.3	111.3	90.8	86.8	100.4	104.9	100.4
1935	95.1	90.1	104.1	108.3	105.4	89.5	84.5	96.4	103.7	99.7
1939	110.2	107.0	118.7	119.8	119.0	105.6	99.3	117.4	121.9	116.5
1946	167.1	167.4	159.1	161.1	158.1	159.7	157.5	157.9	159.3	160.0
1947	202.4	203.8	183.9	184.2	184.0	193.1	191.6	183.7	186.8	186.9
1948	227.9	231.2	207.7	210.0	208.1	218.9	216.6	208.3	214.7	211.1
1949	221.4	220.7	212.8	215.7	213.6	213.0	207.1	214.0	219.8	216.1
1950	232.8	230.7	221.9	225.3	222.8	227.0	223.1	222.4	224.5	222.6
1951	252.0	248.3	238.5	240.9	239.0	245.2	240.4	239.6	243.1	243.1
1952	259.1	253.2	249.7	255.0	249.6	250.2	245.0	245.6	248.7	249.6
1953	263.4	256.4	259.0	267.6	259.2	255.2	257.2	256.6	261.0	259.7
1954	266.6	260.2	263.7	273.3	266.2	257.4	249.2	264.1	272.5	267.2
1955	273.3	266.5	272.2	281.3	276.5	268.0	259.6	275.0	284.4	279.6
July 1956	289.3	280.9	288.5	299.8	294.3	280.6	271.3	290.9	301.3	298.7
Aug. 1956	289.3	280.9	288.5	299.8	294.3	282.0	273.2	293.0	302.2	300.9
Oct. 1956	289.1	280.5	289.2	300.4	296.3	281.0	271.8	293.4	302.5	301.0
Oct. 1956	162.3	162.1	% increase over 1939			167.1	173.7	% increase over 1939		
			143.6	150.8	149.0			150.0	148.2	158.4

Cost comparisons, as percentage differences for any particular type of construction, are possible between localities, or periods of time within the same city, by dividing the difference between the two index numbers by one of them; i.e.:
 index for city A = 110
 index for city B = 95
 (both indexes must be for the same type of construction).

Then: costs in A are approximately 16 per cent higher than in B.

$$\frac{110-95}{95} = 0.158$$

Conversely: costs in B are approximately 14 per cent lower than in A.

$$\frac{110-95}{110} = 0.136$$

Cost comparisons cannot be made between different types of construction because the index numbers for each type relate to a different U. S. average for 1926-29.

Material prices and wage rates used in the current indexes make no allowance for payments in excess of published list prices, thus indexes reflect minimum costs and not necessarily actual costs.

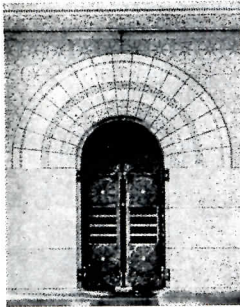

A NEW IMAGE OF
SULLIVAN'S GENIUS
SOUGHT IN BOOK

The Idea of Louis Sullivan. By John Szarkowski. University of Minnesota Press (St. Paul, Minn., 1956) 162 pp. Illus. \$10



WHEN LOUIS SULLIVAN died, desolate, sick, a victim of alcohol, he left to the hands of posterity the fate of his architecture. His 100th anniversary, celebrated in 1956, focused attention on the stamp of acceptance posterity has given Sullivan. Out of the celebration has come a flurry of revitalized interest in his works, writings and influence.

Several excellent Sullivan books went on the market last year, but one which particularly deserves notice is John Szarkowski's *The Idea of Louis Sullivan*, published by University of Minnesota Press.

An architectural photographer, Szarkowski first became aware of Sullivan's greatness through "his intoxicating, inspiring writings . . . (which) showed a man who had demanded wholeness — total humanity — with the passion of few men before or since."

The author hoped at that time to produce an academically serviceable record of the Prudential Building in Buffalo, New York. "The building was old and dirty," he reports, "and largely lost among its newer, larger neighbors. Like a diamond in a pile of broken glass, it stopped few passersby. But it was there to be looked at, and with sympathy and patience it could be seen — and seen to be a masterwork, an image of greatness."

On a Guggenheim fellowship, Szarkowski continued to pursue his study of Sullivan and to take the photographs that are published in this new volume.

His attempt is to catch the *image* of Sullivan. No formal analysis is made; no lengthy biography is given. Sullivan is shown through

(Continued on page 74)

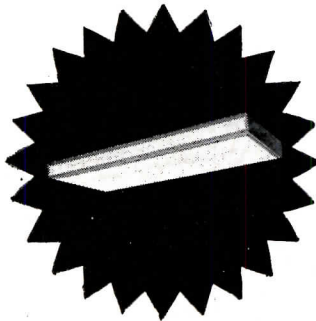
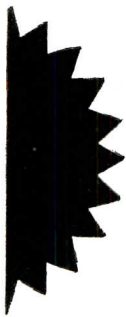

VERSA-LUX.

There's unmatched versatility in this *new* Versa-Lux family, together with a designed-in simplicity of straight-line styling that will satisfy any lighting need.

Wide unbroken surface planes, made possible by rigid hinged steel doors, provide maximum visual continuity. Doors with center mullions are also available to provide a greater selection of media.

Versa-Lux—in two widths for two, four and six lamps*—is *now* available with these glass and plastic lens and panel closures—Holophane Lo-Brite® Controlens® #6016 Flat Plastic, #9016 Flat Crystal, Dished Crystal, Corning #93 Alba-Lite, Polystyrene Plastic Egg-Crate, Honeylite® aluminum louver, or Flat Acrylic Plastic—all of them with fine-ribbed plastic side panels. Versa-Lux installation is simple and versatile; maintenance is minimal.



No matter what kind of lighting you're looking for, at whatever price—Versa-Lux can be the answer, for its versatility is limited only by your own imagination, and its price is set to meet any budget.

**Rapid Start only.*



Versa-Lux specifications available on request.

®Holophane Co., Inc. ®Hexcel Products, Inc.

CURTIS LIGHTING, INCORPORATED

6135 West 65th Street, Chicago 38, Illinois

Versatile Versa-Lux/install them direct-ceiling-mount, partially recessed or pendant mount, individually, in continuous lines or in patterns.

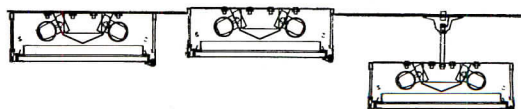

SURFACE MOUNT PARTIALLY RECESSED PENDANT MOUNT

in California: 242 S. Anderson St., Los Angeles 33, California • in Canada: 195 Wicksteed Ave., Toronto 12, Canada

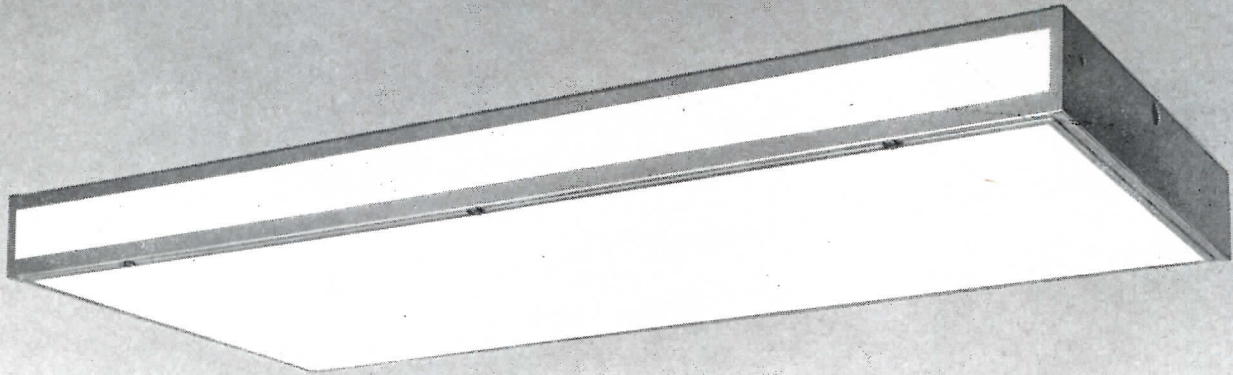

.BY CURTIS



TWO LAMPS

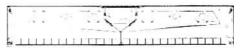

FOUR LAMPS



SIX LAMPS

Versatile Versa-Lux/available in two widths for two, four and six lamps and seven different bottom closures.



See What's New for Your Business

at the

13th INTERNATIONAL HEATING & AIR-CONDITIONING EXPOSITION

(formerly the International Heating & Ventilating Exposition)

INTERNATIONAL AMPHITHEATRE—CHICAGO

FEBRUARY 25—MARCH 1, 1957

Under the auspices of the American Society of Heating and Air-Conditioning Engineers, and in conjunction with their 63rd annual meeting.

YOUR BUSINESS can be better yet — when you give your clients solid “reasons — why” they should install advance-design equipment. To keep ahead of competition, come to Chicago where more than 450 manufacturers will be showing the newest and most efficient heating, ventilating and air conditioning machinery and methods. At the world’s largest exposition of its type, you’ll get new ideas for air conditioning all types of buildings — ideas that will build a future for you.

To be sure you’ll be there, write for advance registration to:

13th INTERNATIONAL HEATING & AIR-CONDITIONING EXPOSITION

480 Lexington Avenue, New York 17, N.Y.

Management: International Exposition Co.

Ⓜ 3555

REQUIRED READING

(Continued from page 71)

the eyes of his client’s, those with whom he worked, and through the beauty of his buildings alone. A short literary profile of Sullivan presents the personality and history of the man, but his genius is recorded in the photographs and brief interviews and selected writings which accompany them.

With great taste, Szarkowski has captured in his pictures what he calls the “life-facts” of Sullivan’s buildings. (Sullivan himself claimed “life-facts” and “art-facts” are the same thing.) Bums and businessmen, maids and street-cleaners, people hurrying-scurrying on their way to work are shown against the background of Sullivan’s dusty elegance. The result is a masterful account of Sullivan’s aspirations for, as well as understanding of humanity.

The text is a combination of quotations from those who knew Sullivan and his work best (including Frank Lloyd Wright), and poignant, powerful selections from Sullivan’s own writings.

Several pages of photographs and text are devoted to Sullivan’s disappointment at the scourge of revived Classicism which spread over America after the Chicago World’s Fair. The revival ushered in Sullivan’s long days of bitterness and poverty preceding his death.

The book is beautifully done, fascinating to read — an excellent memorial to Sullivan on his 100th year.

As Sullivan wrote:

*For, my lad, beauty has not really departed
from the sons of earth*

*Nor is high thinking but a memory of
days gone.*

*Nor is the winsome art of saying done
for.*

Nor has the power of man forsaken him.

*If he has lost them, on his way, he has
but to call to them;*

They will answer and come gladly

His spirit will revive.

Kindergarten Chats, p. 161

— D. T.

MORE ABOUT SULLIVAN

The Architecture of Adler & Sullivan. By Richard S. Nickel. Introduction by Frank Lloyd Wright. Horizon Press (1956) Black and white and color photos courtesy Illinois Institute of Technology

(More reviews on page 380)



COURTHOUSE AND JAIL, BRAZOS COUNTY, TEXAS



Ulric Meisel

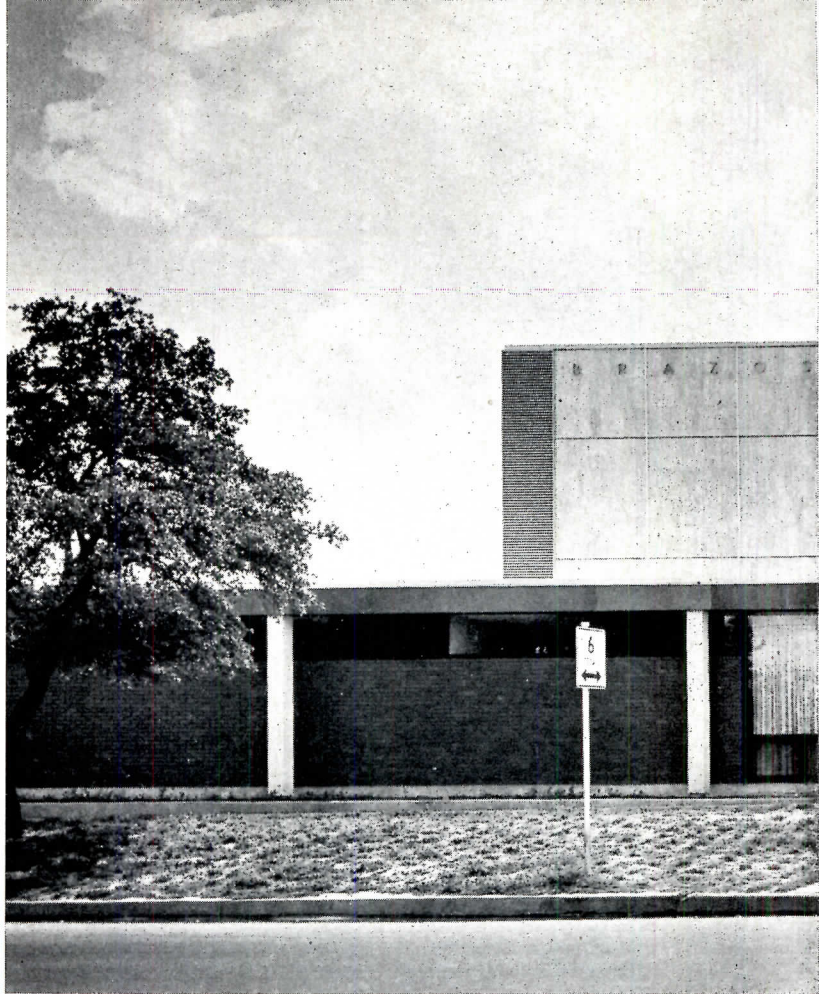
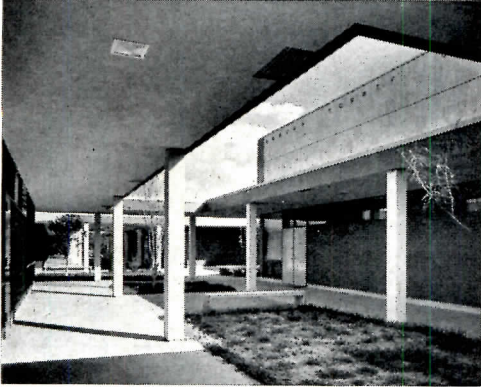

BRAZOS COUNTY COURTHOUSE AND JAIL

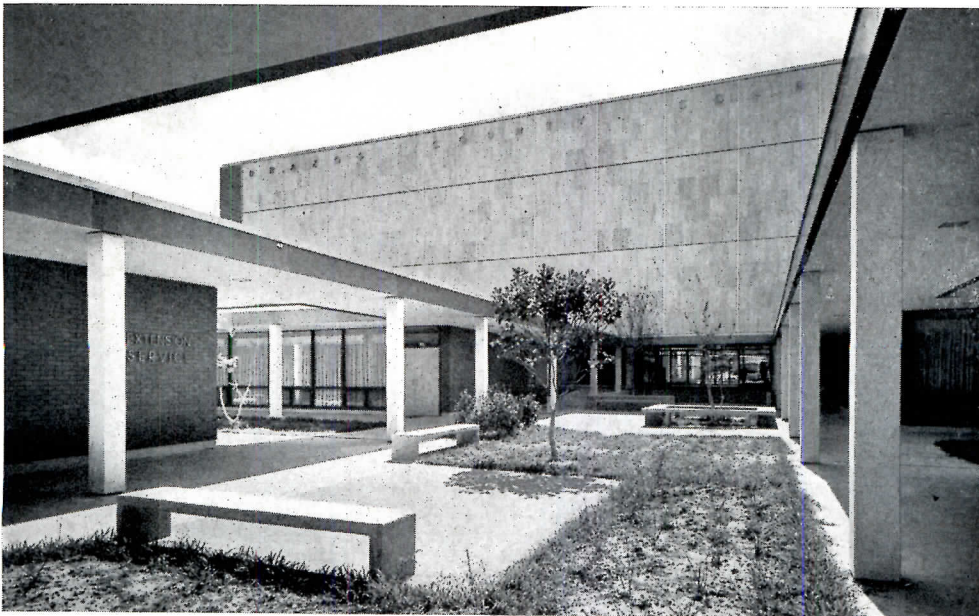



Architects: Caudill, Rowlett, Scott & Associates

Consulting Engineer: W. E. Simpson Co.

Mechanical Engineer: J. W. Hall, Jr.

Interior Planning: Knoll Associates

Landscape Architect: Caldwell & Caldwell

General Contractor: A. P. Kasch & Sons

UNFORTUNATELY, one is seldom able to visualize the typical county building — most likely 50 to 100 years old — as either attractive or convenient. The spaces behind its usually pompous façade are often ill-planned, poorly lighted, and depressing for public and employes alike. Thus, when a new county building does provide a generous measure of both amenity and good looks, it assumes unusual significance. The Brazos County building so qualifies.

Its unique “campus-type” plan resulted from extensive study of the problem (see ARCHITECTURAL RECORD, July, 1955 for that story). The county business and service offices — clerk, taxes, health, education, and welfare — are placed in expandable, individual units with separate ground-floor entrances;

the judicial functions — jail, courts, and offices — are arranged within a four-story unit providing complete separation of lawbreakers and public. The interiors are well handled, with color schemes that are interesting without being gaudy. The overall character of the design is fresh, lively, and friendly, yet appropriately dignified.

One might wish for a larger plot, so the various units might have spread out in more expansive fashion, with better separation and more generous courtyards between; and with more adequate parking for the whole. As it stands, however, this courthouse and jail takes a large forward step in the development of a smoother working, more attractive kind of public architecture.

25th street

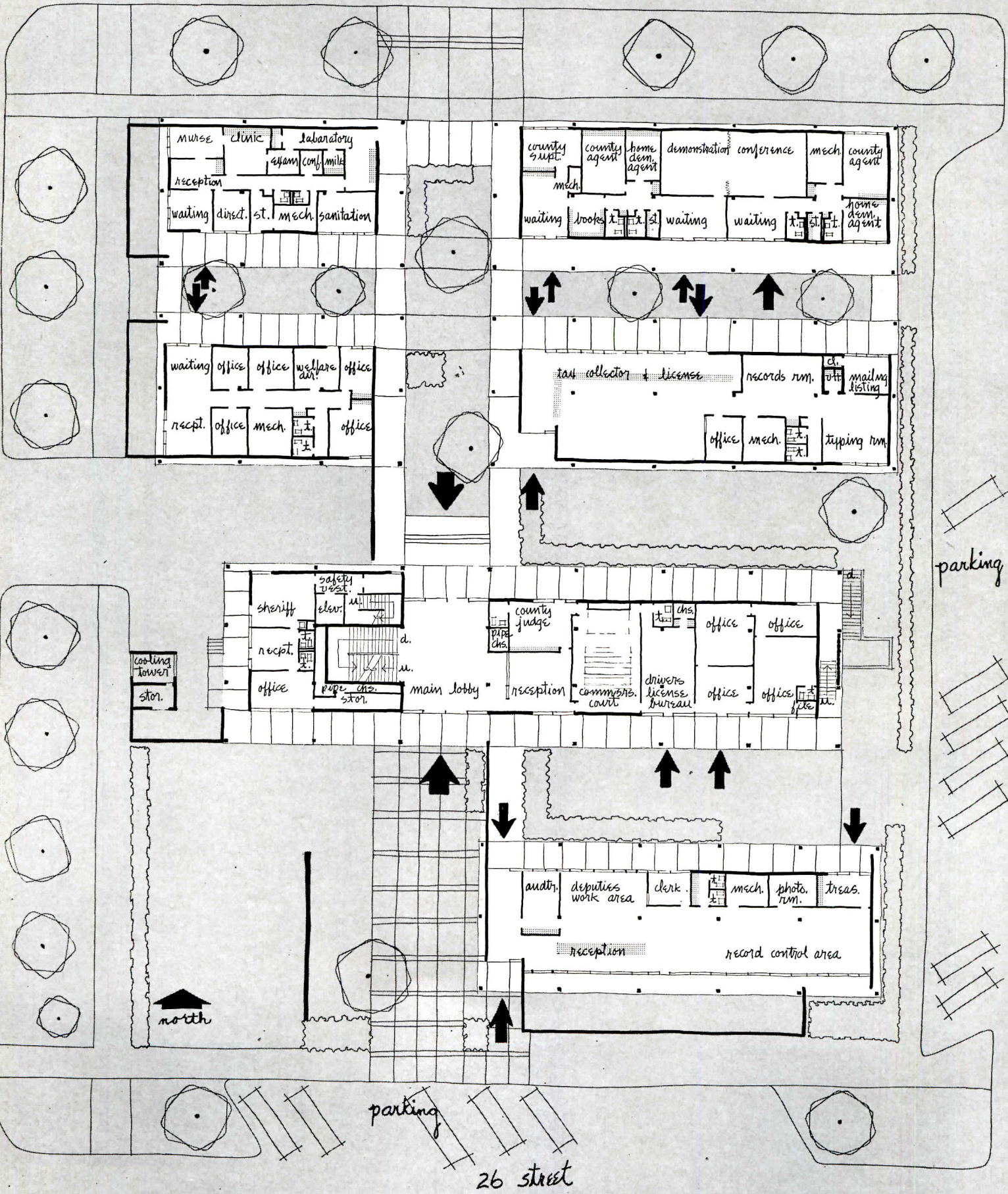

parking

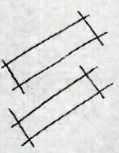
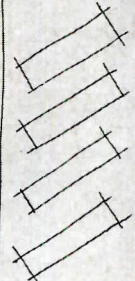

parking

26 street

scale 10

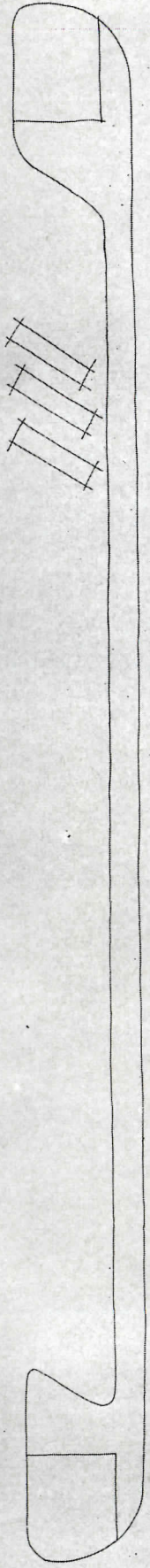

Ronald Chatham



BRAZOS COUNTY COURTHOUSE AND JAIL

The jail is located on the top floor of the four-story building; jury rooms, probation offices, and civil defense on the third; two courtrooms and ancillary areas on the second; while the first floor (straddling the main walkway) houses a separated jail entrance, judge's chamber, commissioners' court, and drivers' license bureau.

The five smaller one-story units contain the following departments: top left, county health; top right, education and extension; second left, public welfare and veterans' service; second right, tax assessor and collector; bottom, county clerk, auditor, and treasurer.

Separate auto entrances and parking areas are provided for the jail, county officials, and public.

Exterior walls are of red brick and travertine; the lowers are aluminum; the windows are painted steel, projected type.

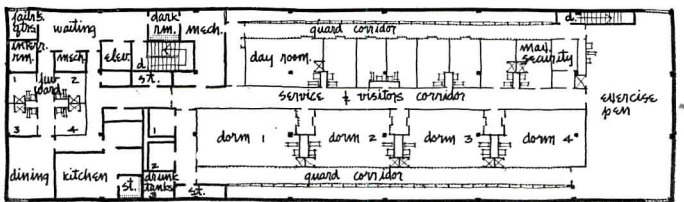

FOURTH FLOOR

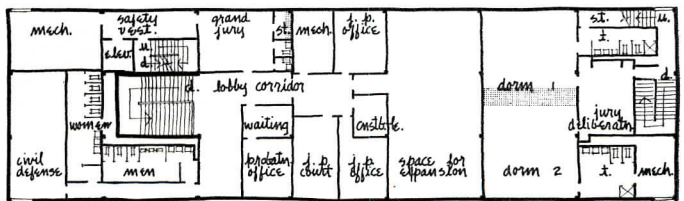

THIRD FLOOR

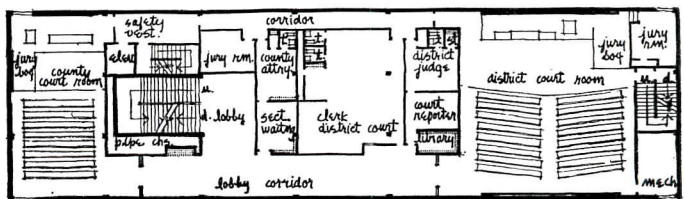

SECOND FLOOR scale 1/8" = 1'-0"

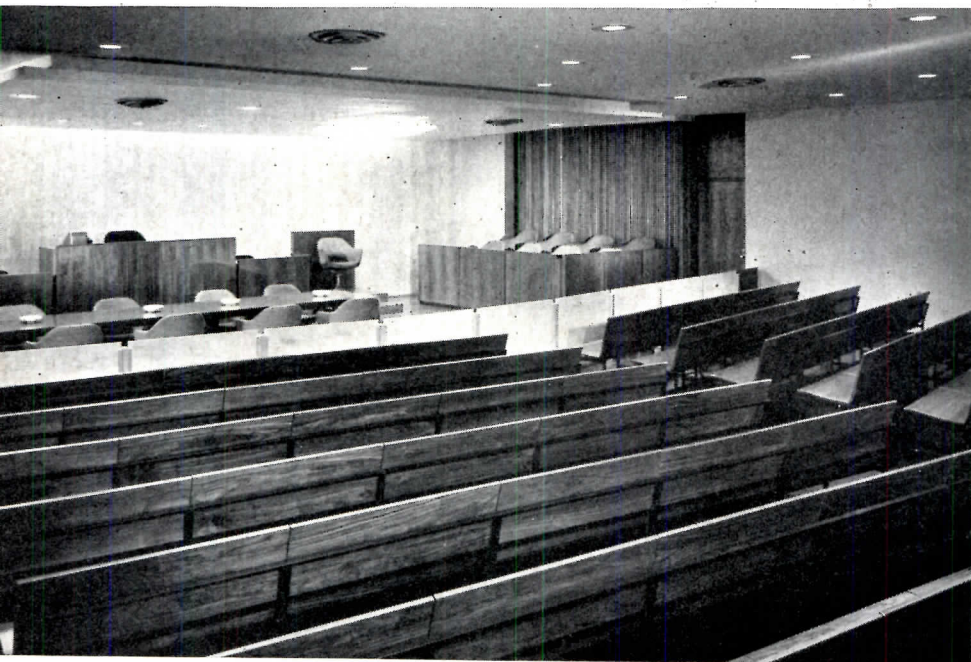
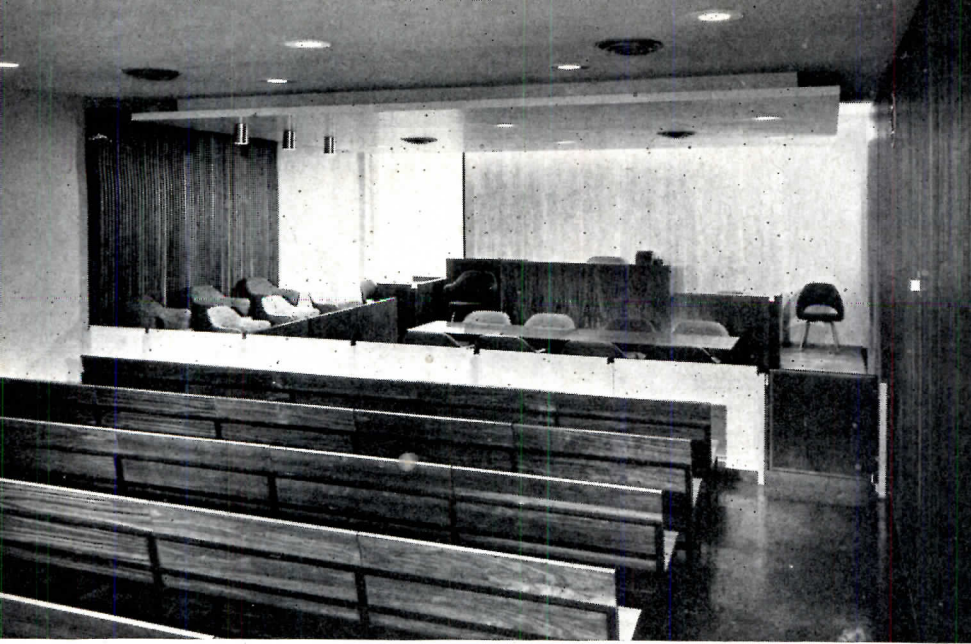

BRAZOS COUNTY COURTHOUSE & JAIL

In the two courtrooms shown at left, the spectator benches are of laminated walnut on steel frames which are oxidized black; the floors are asphalt tile with vinyl base; the curtains are of white plastic casement cloth; both rear walls are Tuscan travertine.

The County Court, top, which seats 80, contains black and white linen jury chairs; blue and black linen counsel chairs; and a charcoal gray witness chair.

The District Court, center, which seats 150, contains witness and jury chairs of gray, black, and white linen; counsel chairs of persimmon and black linen; and a judge's chair of black plastic.

Note that the witness is highlighted by a large fixture and is not enclosed; observation of the witness and his movements is considered very important.

The judge's chamber, bottom, has walls of plaster and red brick; judge's chair of natural calf; armchairs of brown and black wool. The desk top is a walnut plastic laminate on a black frame. A rarely used "escape door" is hidden by the white plastic casement cloth curtains

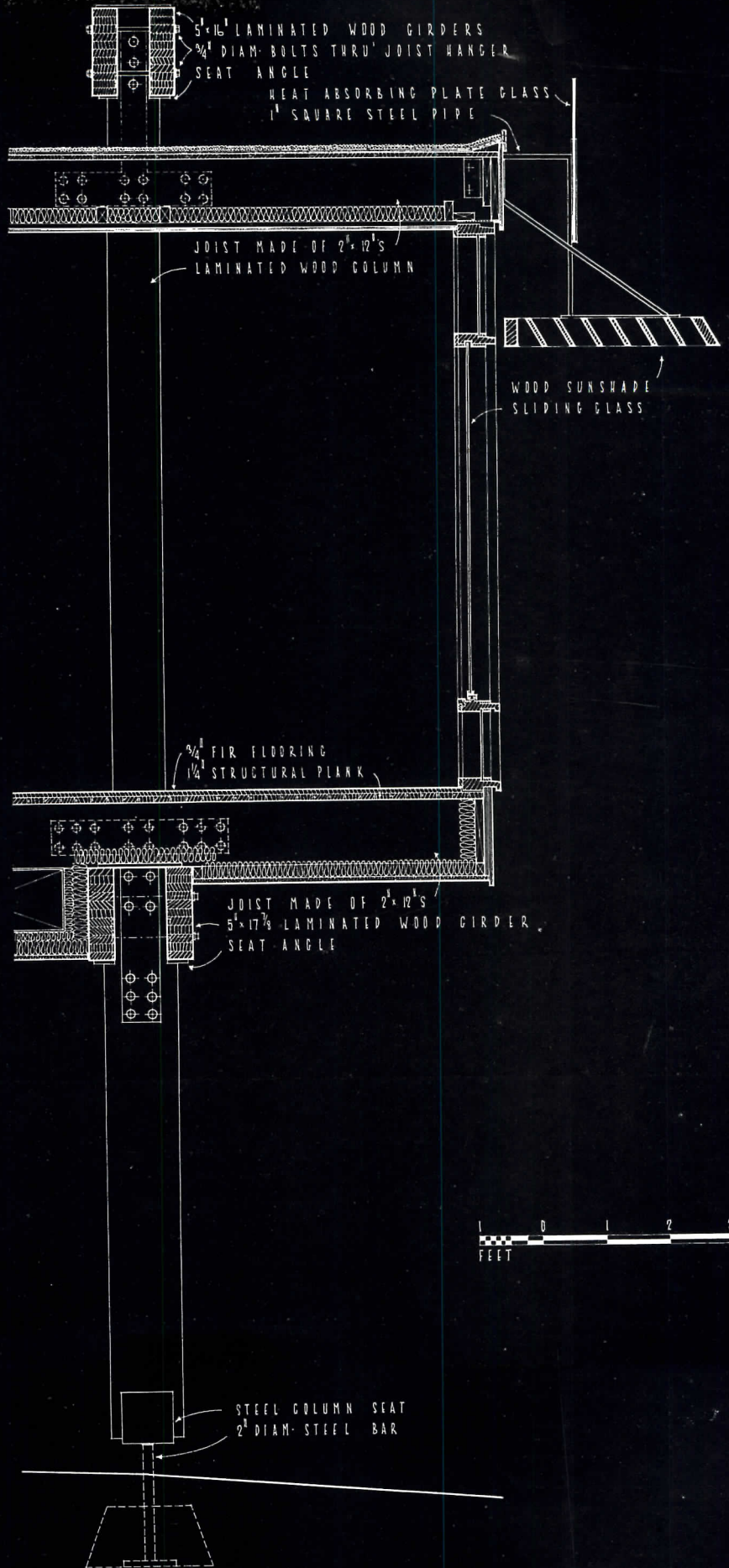

THE STARKEY HOUSE

Marcel Breuer, Architect

Herbert Beckhard, Associate



Warren Reynolds for Infinity, Inc.

THE STARKEY HOUSE

THIS HOUSE is notable for its juxtaposition with nature; and in considering the significance of that relationship, we are reminded of interesting differences in architects' thinking about the house and its environment.

Long ago Frank Lloyd Wright romantically snuggled Taliesin against a Wisconsin hillside; designed it to "grow out of and become a part of" the setting. Recently — with more classic severity — Philip Johnson placed the Hodgson House upon a level, raised, earthen "podium" in a clearing on a wooded slope

in Connecticut, thereby dramatically pitting architecture against nature. Now, Marcel Breuer has built the Starkey House to soar bravely free of a rocky Minnesota hill, with its structure touching down at only eight points. His thinking: architecture has one character, nature another; the integrity of each is to be maintained and not intermixed with the other. Therefore, visually separate them; play one against the other. Hence, this unsullied geometry flying over the almost unchanged slope; an exposition in rationalism.

UPPER LEVEL

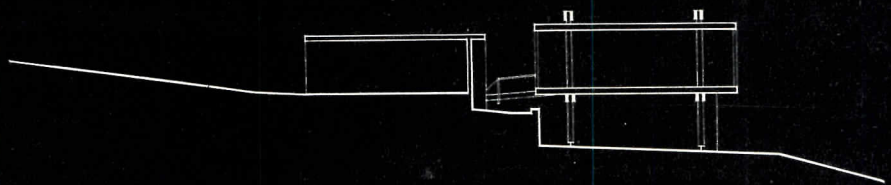
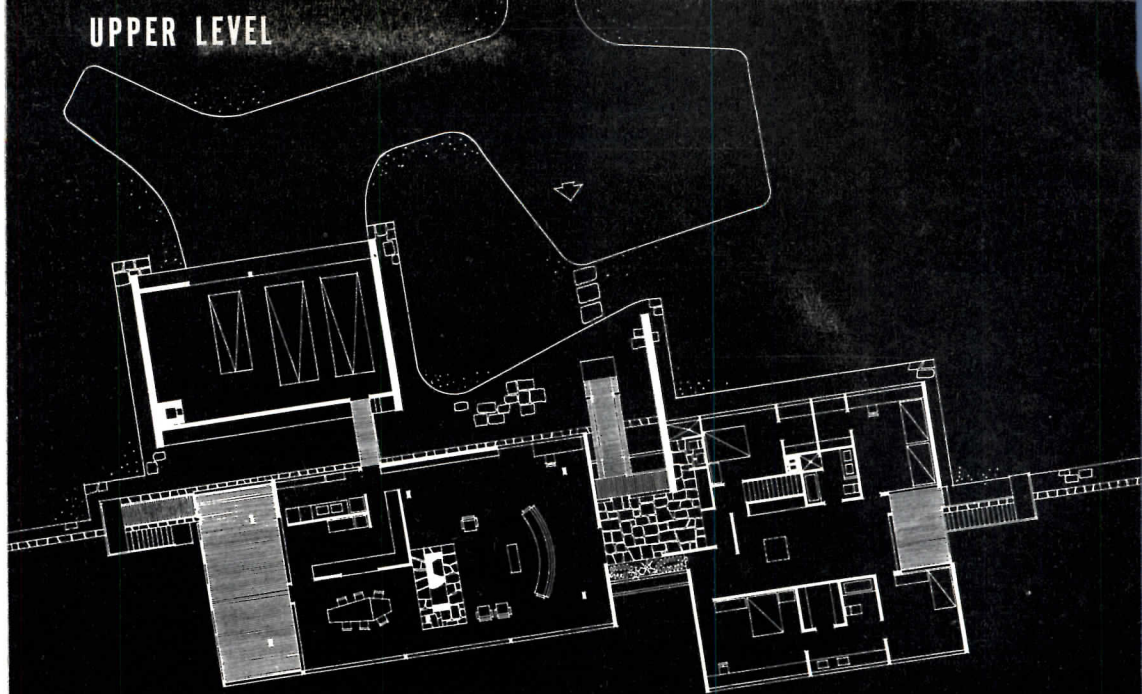

LOWER LEVEL

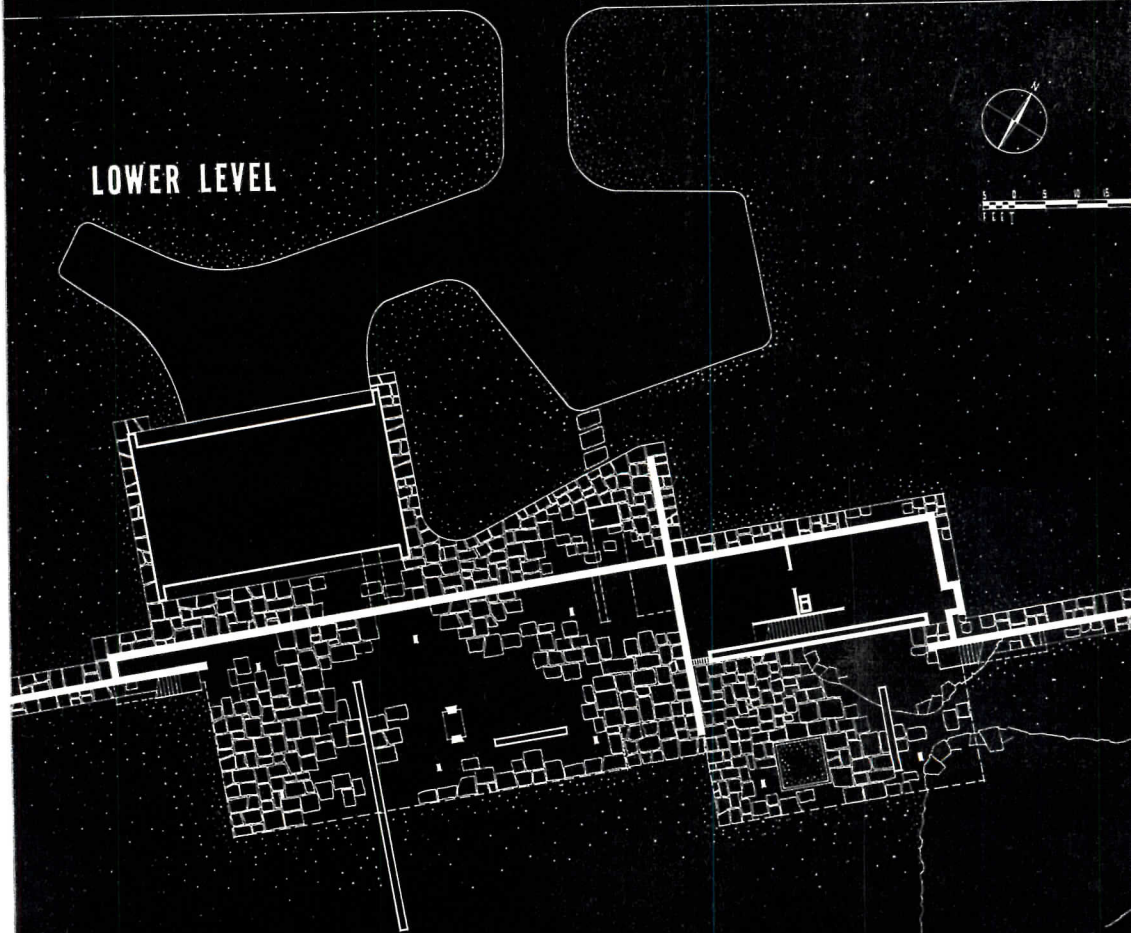

Location: Duluth, Minn.

*Marcel Breuer
Architect*

*Herbert Beckhard
Associate*

*Fred S. Dubin Associates
Mechanical Engineers*

*Weisenfeld & Hayward
Structural Engineers*

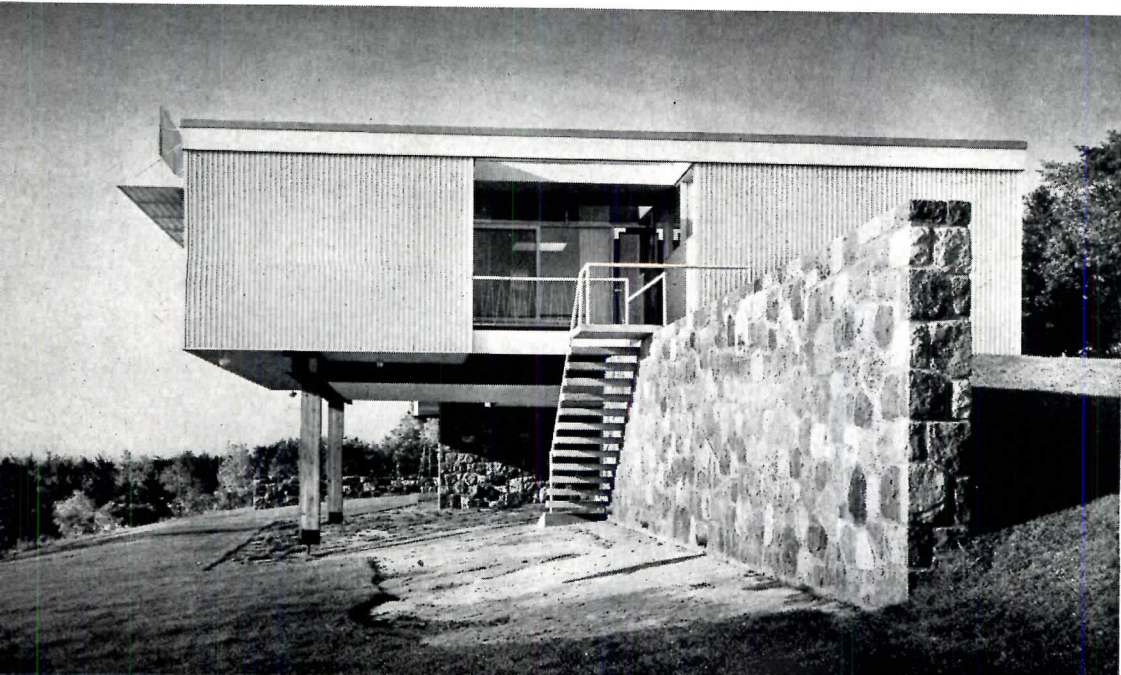
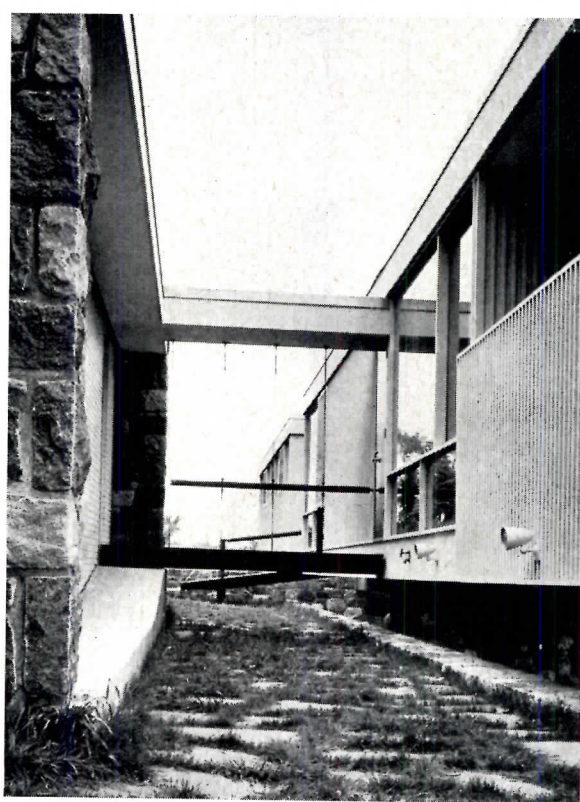
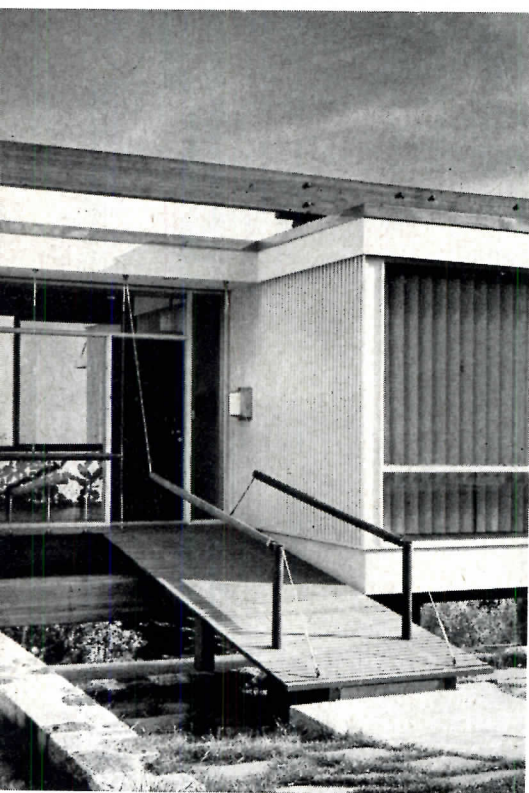
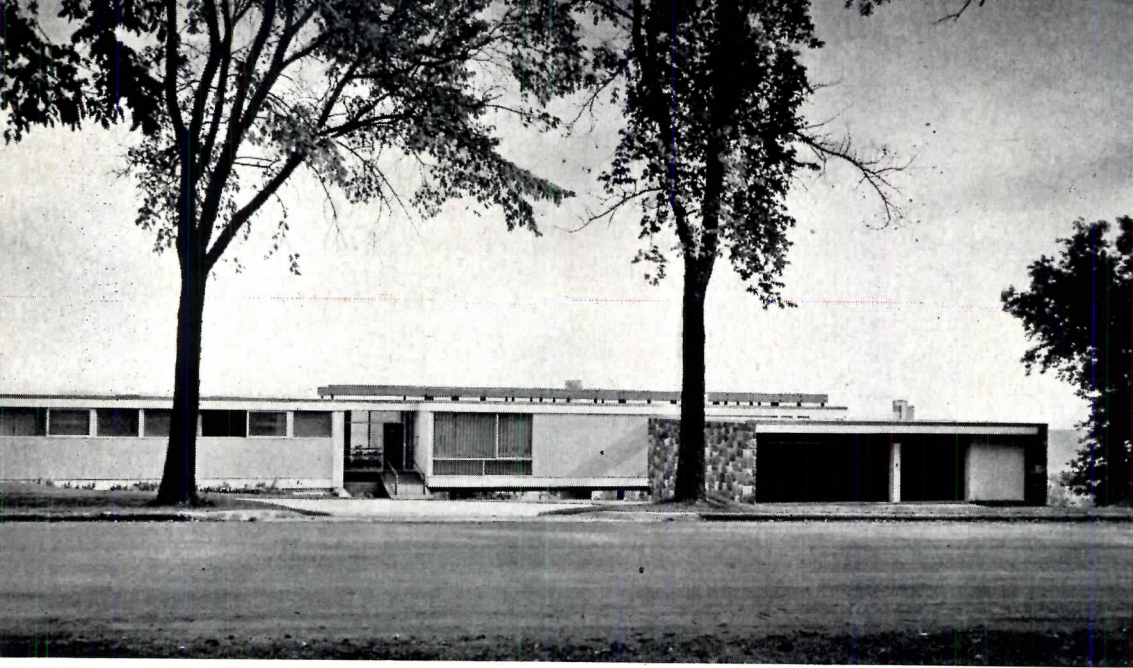

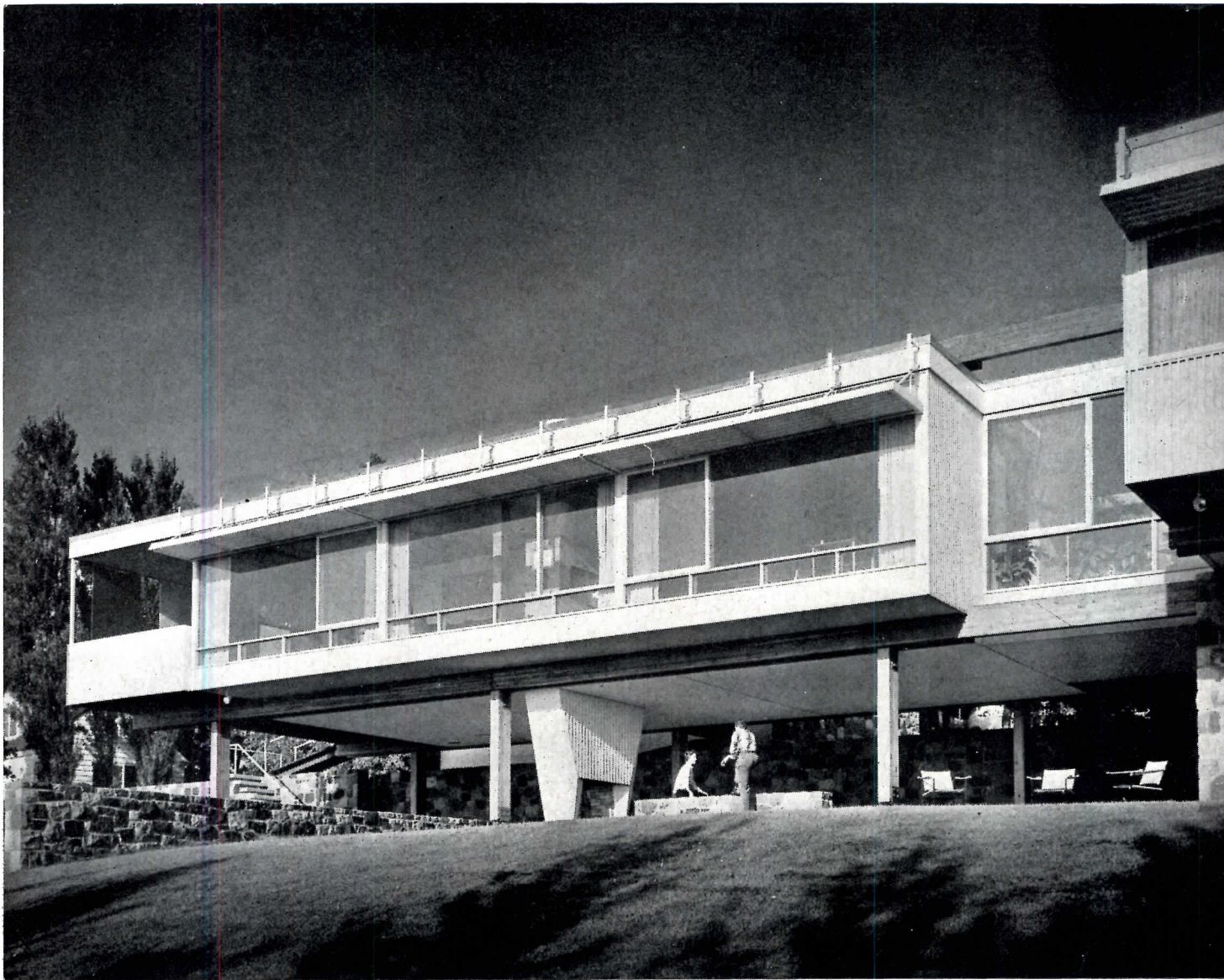

THE STARKEY HOUSE

Except for the garage unit and heating room, which are necessarily earthbound, the house floats free of the rocky slope and is carried by laminated wood posts standing on steel pins that reach down to bedrock. The floor framing is supported by longitudinal laminated wood girders, while the roof structure is suspended from similar girders by means of intermediate steel hangers. The roof is hung in order to provide a smooth interior ceiling.

The house can be reached only by bridges. The main entrance ramp leads to a glass en-

closed link connecting the two elements of the binuclear plan: living areas and kitchen are to the right; bedrooms and childrens' quarters to the left. The earthbound garage is connected to the kitchen-utility area by a bridge while two porches — one at each end of the plan — serve as connecting elements between the house and the stairways leading to the ground. The open area beneath the suspended living-dining area serves as a sheltered outdoor recreation and dining space, the feature of which is a concrete fireplace, above.

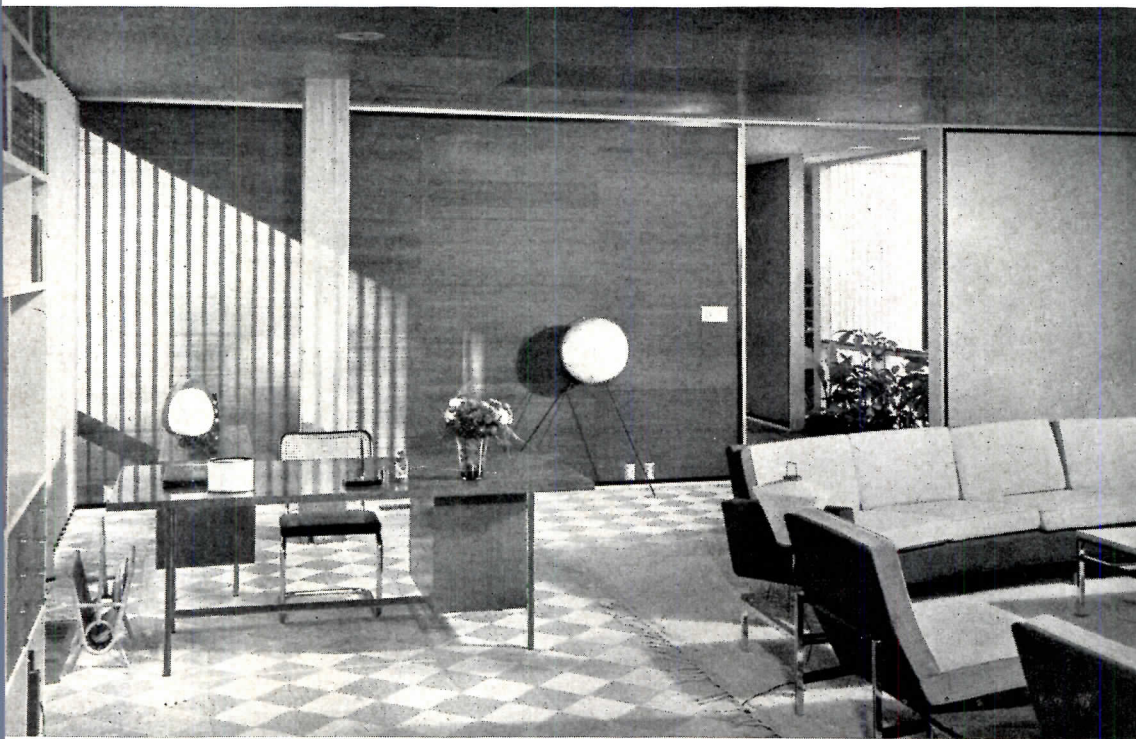
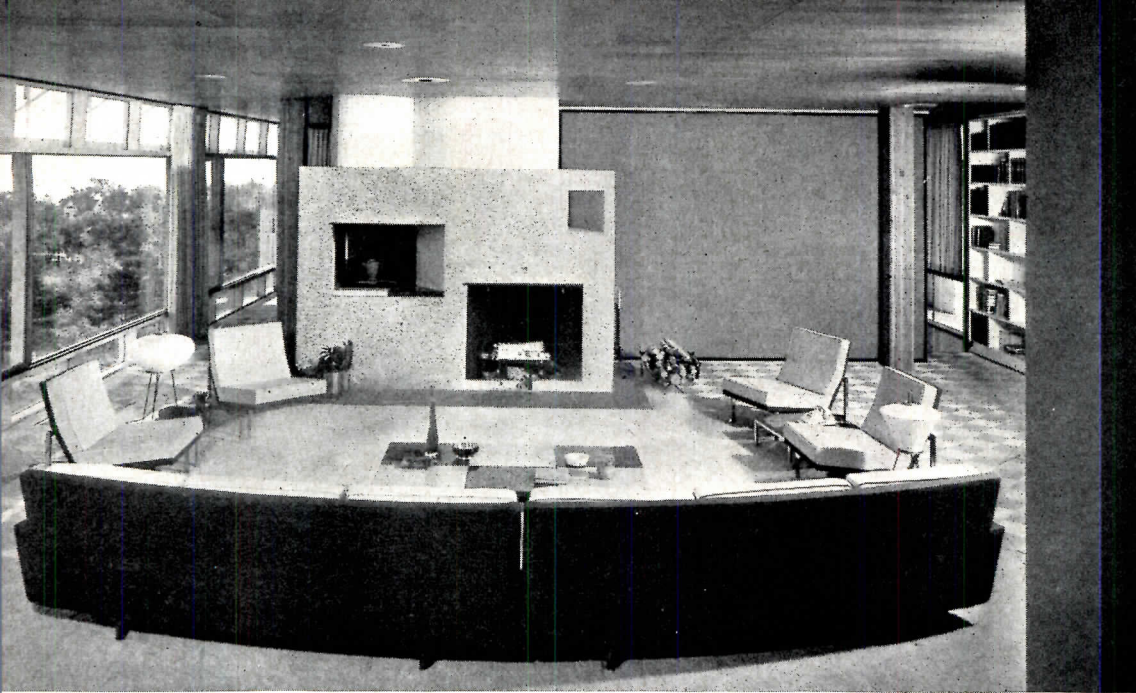

THE STARKEY HOUSE

The living-entrance-dining area has a natural birch ceiling; floor coverings are Philippine rush squares and unbleached white wool Moroccan carpeting; the columns are laminated wood left natural; the glass curtains are natural raw silk. The walls are generally white throughout, except that certain of them are covered with rough silk in vivid red, yellow, or blue for accent. The dining table and cabinet (Breuer designed) are of teakwood; a sliding panel conceals the pass-through to the kitchen.

The two-way fireplace serves as both a space divider and a three-dimensional decorative feature. Its textured surface is white concrete which has been "bush-hammered" to expose the marble and granite aggregate. The through opening houses a charcoal broiler

Prize Winning Designs and Report of the Jury

HOME FOR THE AGED COMPETITION

SPONSOR

*The National Committee on the Aging
of the
National Social Welfare Assembly*

CO-SPONSORS

*ARCHITECTURAL RECORD
THE MODERN HOSPITAL*

THE JURY

*Pietro Belluschi, Chairman
Richard J. Adams
Ollie A. Randall
Charles F. Wilinsky, M.D.
William Wilson Wurster
I. S. Loewenburg, Professional Adviser
Edward H. Noakes, Consulting Architect*

Report of the Jury

By **PIETRO BELLUSCHI**, *Chairman*

THIS COMPETITION was motivated by the desire to find likely solutions to the problem of housing our older people. While the results were judged by the usual architectural standards they must also be viewed in a much larger social context. Architects, particularly the younger ones, take pride in the fact that they are becoming more aware of human and social values. They believe that if their profession has made contributions of any great value to our present civilization, it has not been in erecting monuments or palaces or cathedrals or grand scale city plans, but in creating establishments for the use and comfort of the average human being.

This competition for a home for the aged, and the solutions entered by many architects, confirmed the maturity of approach taken by our profession. The competition has given us, if nothing else, a glimpse of the many ways in which the problem can be met, and perhaps even more importantly has shown the necessity of defining its limits.

The architects who will be asked to design these homes in the future must be told clearly for whom they are to build, that is how old are the persons to be housed, what kind of care they should receive, how much freedom they should have. Someone must decide how much our society can afford to do. Should we attempt to make it so easy and attractive for men and women of minimum social security age (I mean at 62-65 years of age) to live in such ideal conditions that all our resources will be exhausted before we can take care of the older and more helpless cases? Should we think of them as people beginning a new and more sheltered life, where all the opportunities of social contact are preserved and even enhanced, or are we to give more weight to the ones who need protective and health care?

These are not idle questions; they have their advocates and their merits, but all of them will directly and indirectly affect the selection of site, the expenditure of funds, the size of the establishment, and above all the design of the plans and details of the buildings which are to shelter them.

The jury was conscious of the complexity of the problem but endeavored to judge each entry on the bases which were wisely outlined in the program: *plan relationship* which means to show a clear, simple and practical plan; *economy of space* which of course means not only first cost economy but also economy in administration; *quality of environment* which means architectural merit, if this is understood to mean a sensitive use of space, a concern for the appropriateness of scale, color, and light, and for graciousness of detailing; finally, *structural practicability* which is also a test of good overall design and of economy of means.

The winning design by J. J. Jordan and Hanford Yang of Philadelphia was the unanimous choice of the committee. It seems to combine in a rare and self-assured manner the best qualities of all other entries. The plan has logic and clarity; it suggests space pleasant to live in and easy to supervise and administer. The clinical facilities, although separate, are convenient and well located in relation to the administrative unit. The recreation area is in a most appropriate relationship to the living units; these in turn have been so designed as to create a gracious environment. The exterior design is restrained, yet warm, appropriate without affectation, depending on good relationship of spaces and on the garden-like courts to obtain a homelike effect rather than on superficial or fashionable tricks. The jury was very happy to recommend it as an excellent example

1

FIRST PRIZE — \$5000

Joe J. Jordan, Philadelphia
Hanford Yang,
School of Architecture
and Planning, M. I. T.

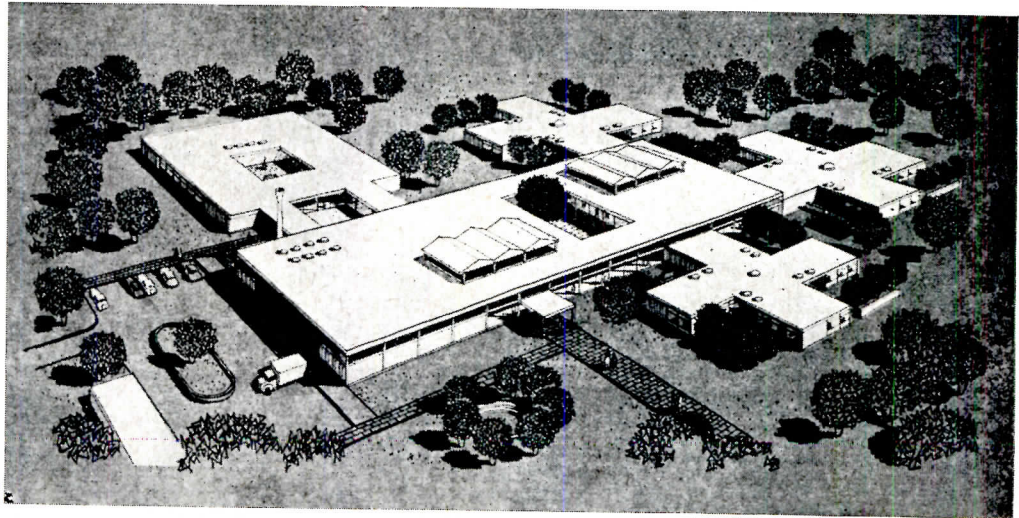

to be studied with care, although not necessarily to be adopted without taking into consideration the special conditions which will always affect individual projects.

The project which placed *second*, entered by Alfred and Jane West Clauss of the firm of Bellante & Clauss, was thought by the jury to possess many of the virtues of the first award; although its plan has less clarity, and the circulation is not as good. The layout of the infirmary is very efficient, perhaps more so than that of the first prize, yet it is not as accessible to the administration or to the services, even if a case can be made for placing it on the second floor. Of the two or three similar schemes, having clustered living units, this was not the most brilliant from an esthetic point of view, but was the most easily defended in terms of circulation and relationship of the units to the intervening courts.

The exterior design was good even if a little self-conscious in the treatment of roofs; all in all, the jury felt it possessed great qualities of warmth and a pleasant human scale.

The *third* prize by Gerhardt Liebmann of New York City won the jury by its charm and by the informal residential character of its parts. While the administration of its living units would obviously be made difficult by their separation from the main building, the jury felt that in this case and other cases where site and climate are favorable, such difficulty may be justified by the desire to provide smaller, more intimate, and less institutional grouping of residents' rooms. The jury also recognizes that some efficiency and clarity of circulation in the central building was somewhat sacrificed in order to obtain such pleasant surroundings.

The jury debated longest on the checkerboard scheme proposed by the team of Katz, Waisman, Blumenkranz, Stein & Weber of New York City. It is a brilliant effort by talented designers. The serious objections raised by some members of the jury to the rigidity of this pattern may be met by the argument that by using

the same size units throughout, prefabrication and great economy can be achieved. However, the general circulation to and through the units and relationship between parts and functions are so adversely affected by this arbitrary scheme that the jury as a whole could not bring itself to give it more than a "mention." The jury must add that much of the fetching quality of this entry was obtained by the ingenious and spirited treatment of the various courts as living and recreational units.

Another scheme which merited the jury's attention was by the firm of Bellante and Clauss of Philadelphia with Hans Egli the designer. Its appeal rests on its economy of land, all functions with the exception of living being condensed in a six-story building. Unfortunately, this virtue caused its gravest fault—the splitting of the infirmary into two stories, an impossible solution from an economical and administrative point of view. The jury admired the composition of the units and the eloquence of the first floor plan, particularly of the residential wings, whose layout expresses in a masterly way how a multiple living environment should be planned.

Finally the jury selected for mention the scheme submitted by Norman H. Hoberman & John Gallagher, Cambridge, Mass. It is the best of several schemes developed for a high-rise multi-story building. The plan is compact and efficient and it has attempted the difficult task in a tall building of providing a warm human environment. The jury liked the scheme in spite of the confused and fragmented exterior composition.

The jury admired many other entries, the list of which would be too long to recite.

I will say in behalf of the jury that we were pleased with the results. We realize that much thinking has yet to be done on the problem, but we believe that these examples will serve as a stimulus, and certainly as a starting point, in our quest for the ideal solution to every case which shall come to all of us for solution.

INFIRMARY

BED PATIENTS

AMBULANT

STAFF

STAFF

ALL PURPOSE ROOM

ADMINISTRATION

SERVICE

RESIDENCE
UNITS

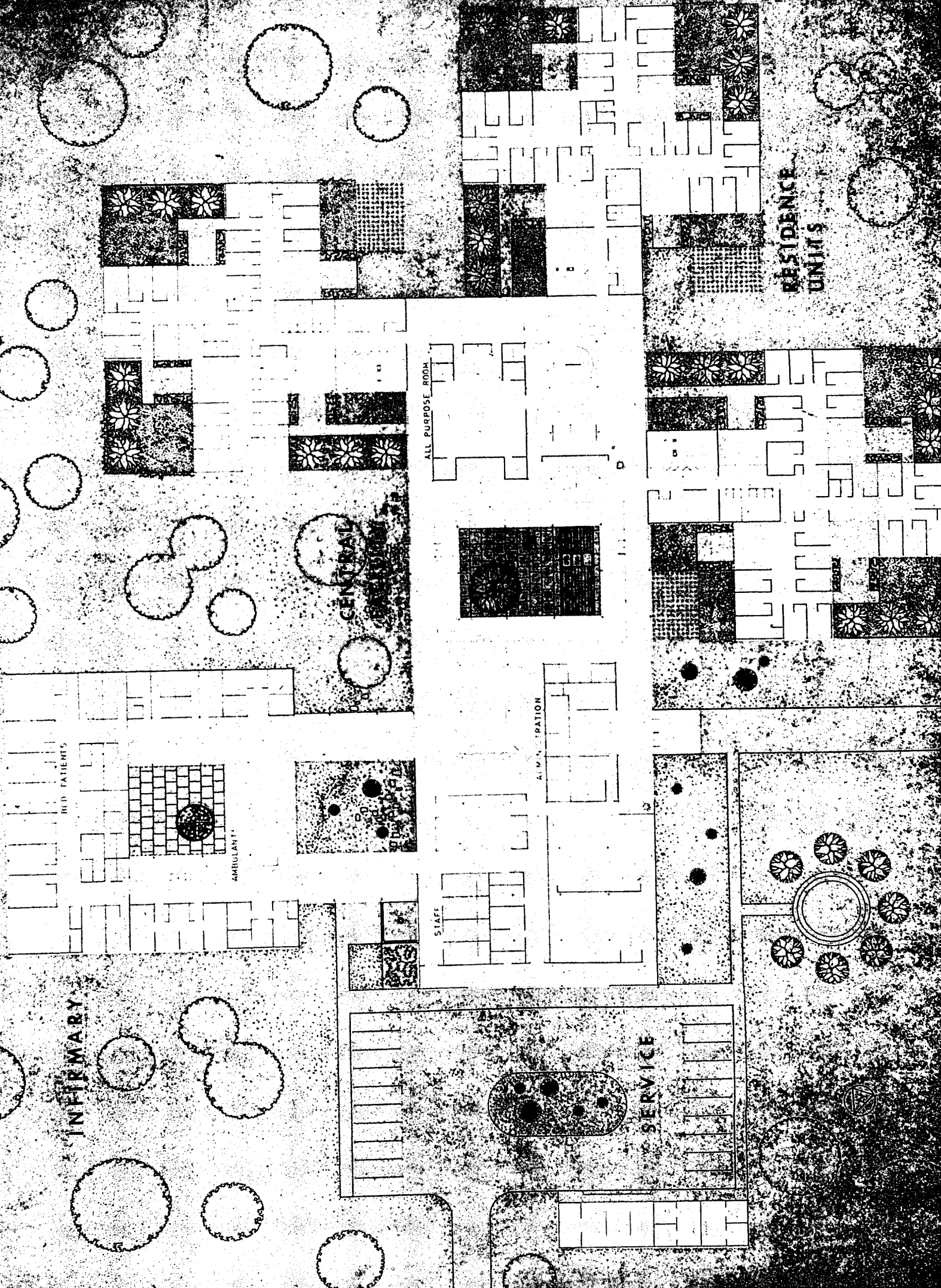

2

SECOND PRIZE—\$2,500

Bellante & Clauss, Philadelphia

Jane West Clauss

Alfred Clauss

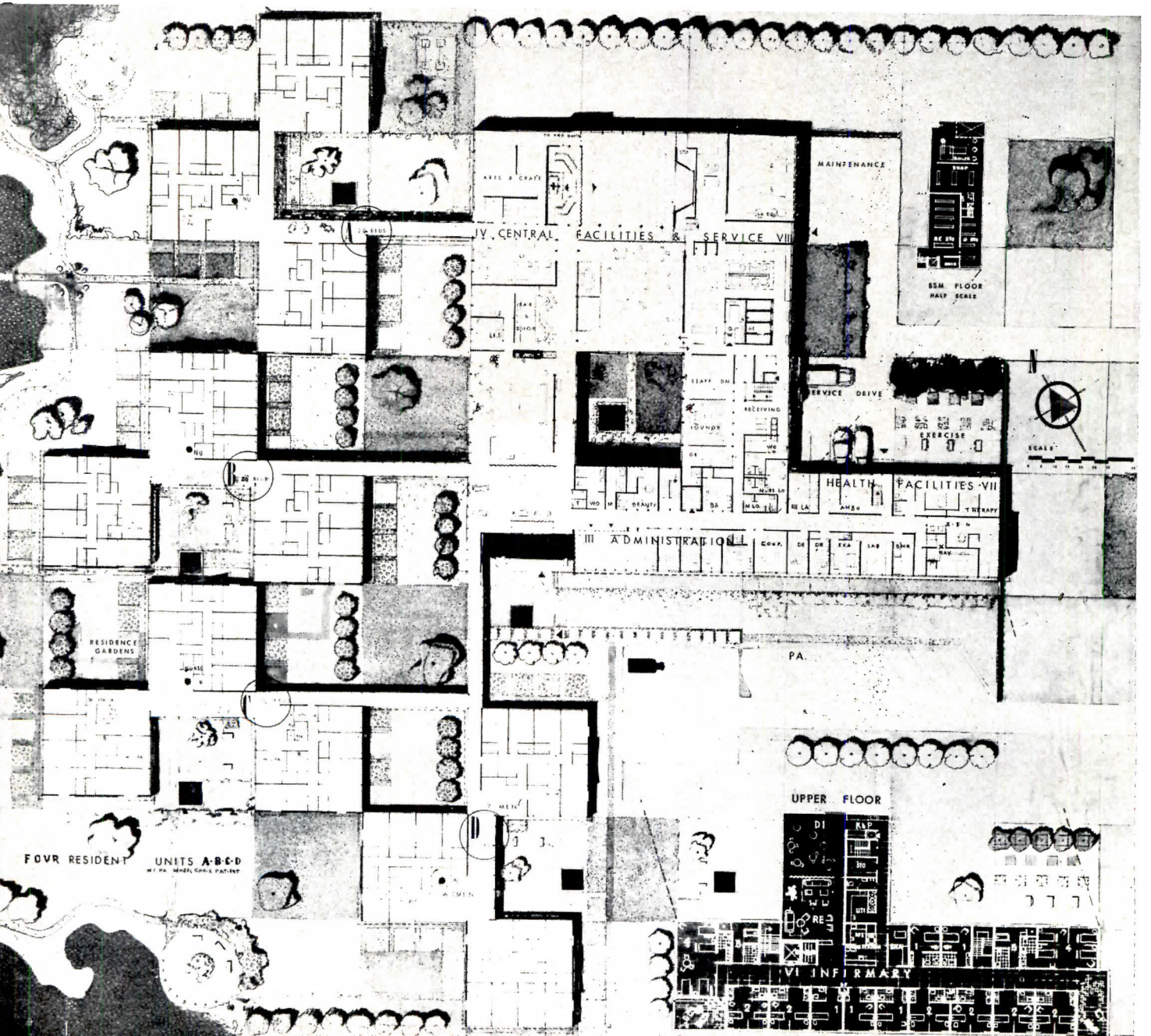
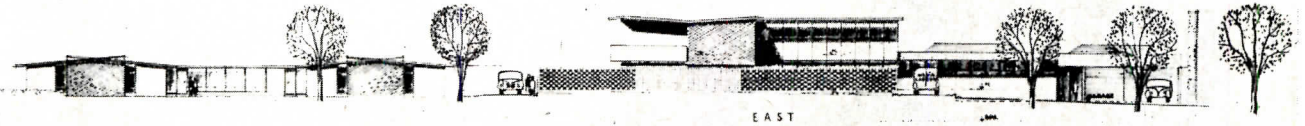

M

HONORABLE MENTION — \$500

Bellante & Clauss, Philadelphia

Hans G. Egli

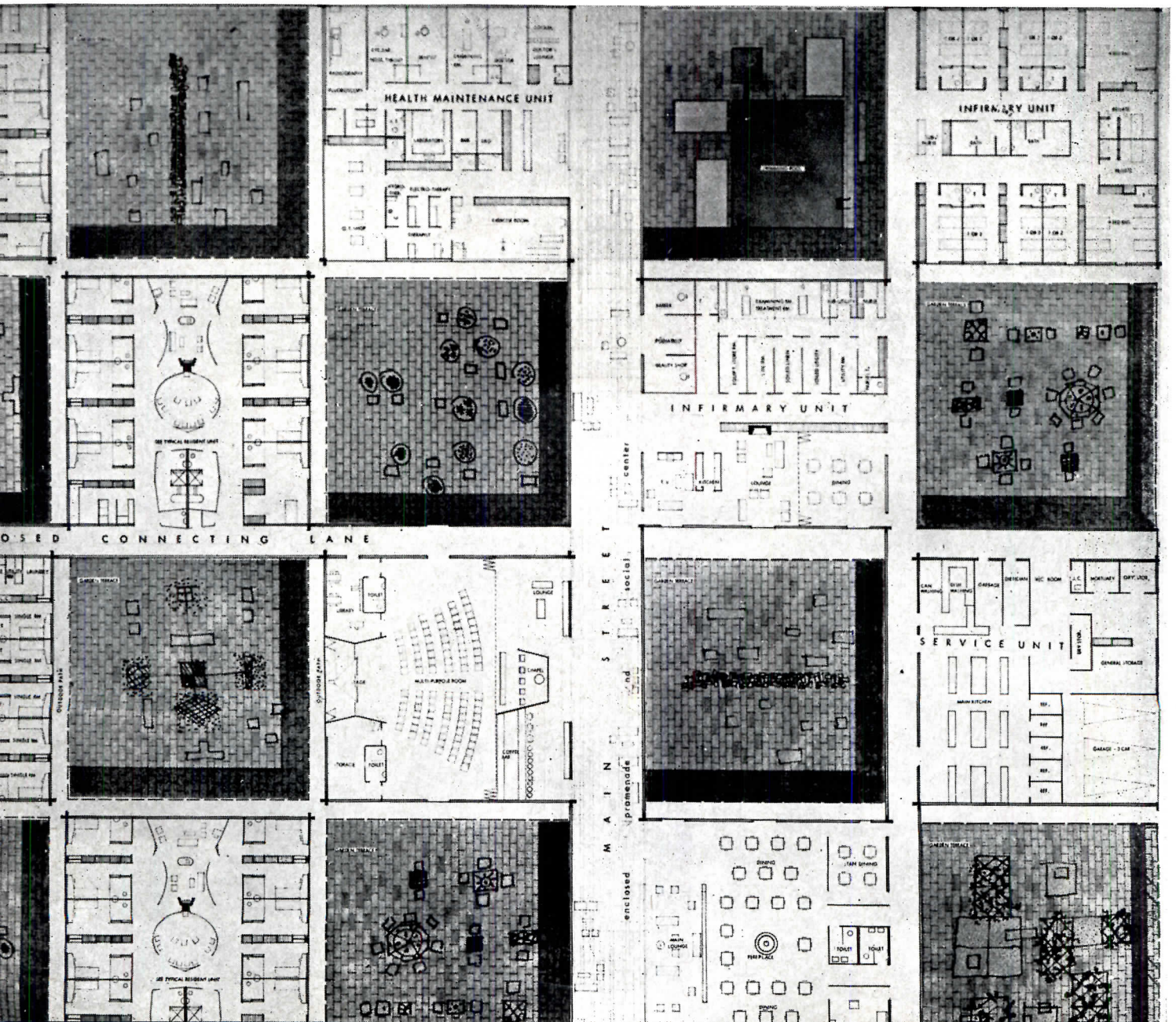
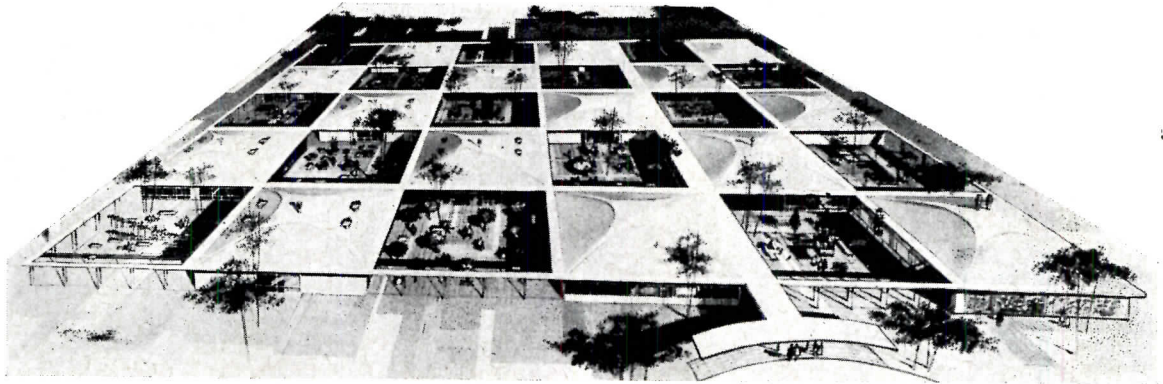

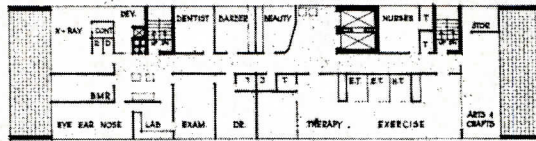
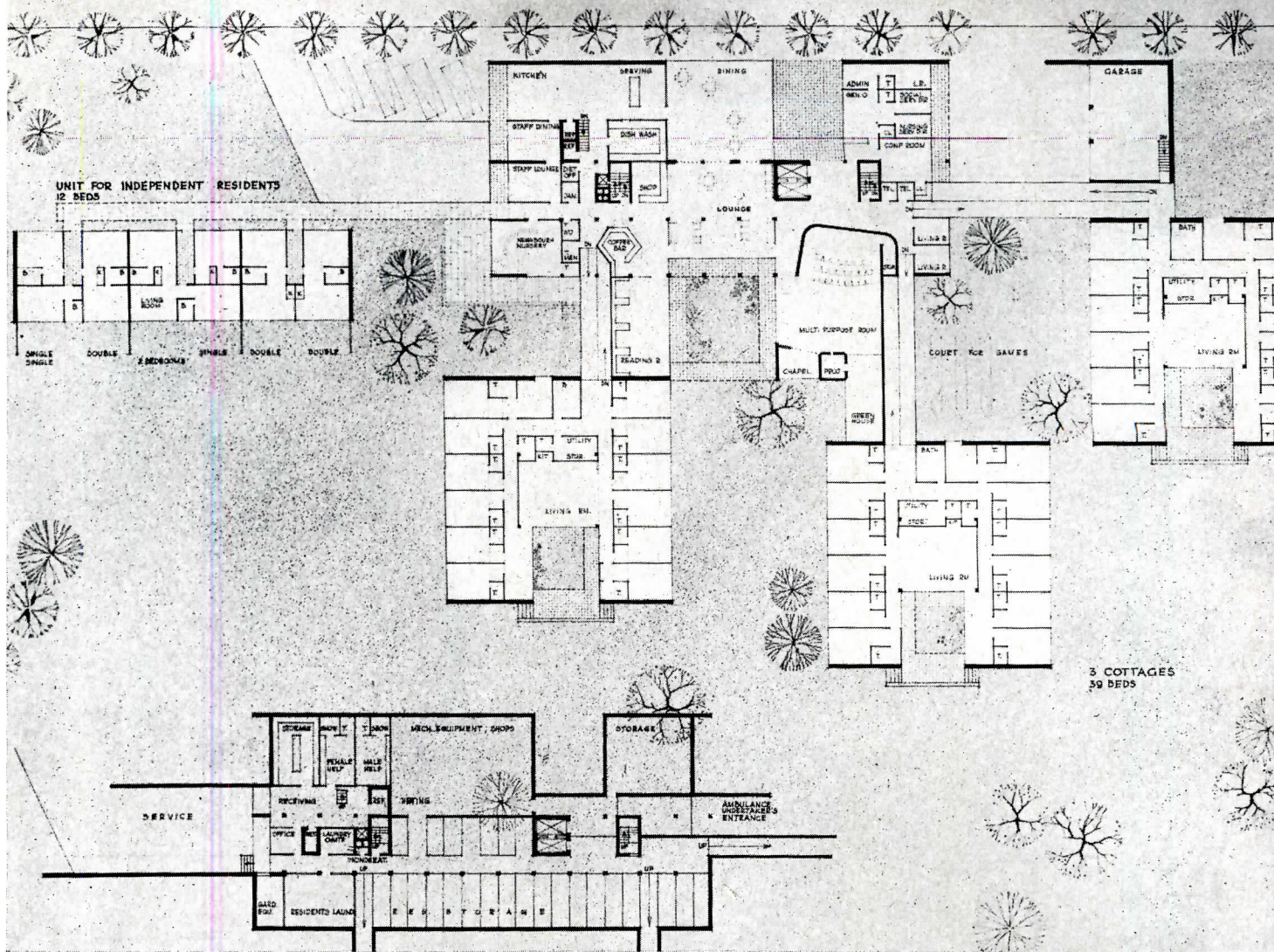

SECOND FLOOR
HEALTH MAINTENANCE
FACILITIES

M

HONORABLE MENTION — \$500

Architects Associated, New York City

Sidney L. Katz

Taina Waisman

Joseph Blumenkranz

Richard G. Stein

Read Weber

Consultants:

Costantino Nivola, Jerome L. Strauss

Patrick S. Raspante, Ricardo Scofidio

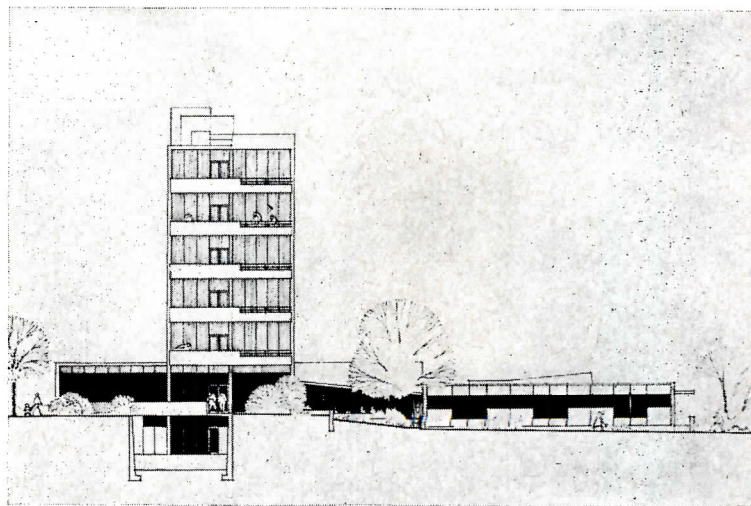

M

HONORABLE MENTION — \$500

Norman L. Hoberman

John W. Gallagher

*both of Graduate School of Design,
Harvard*

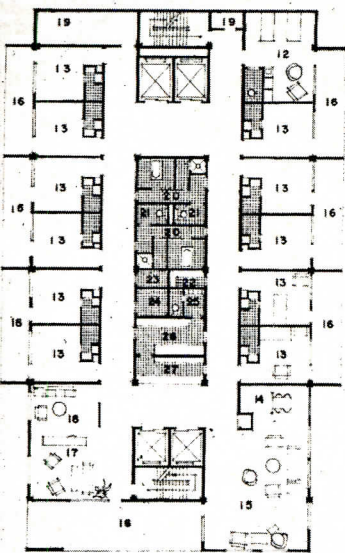
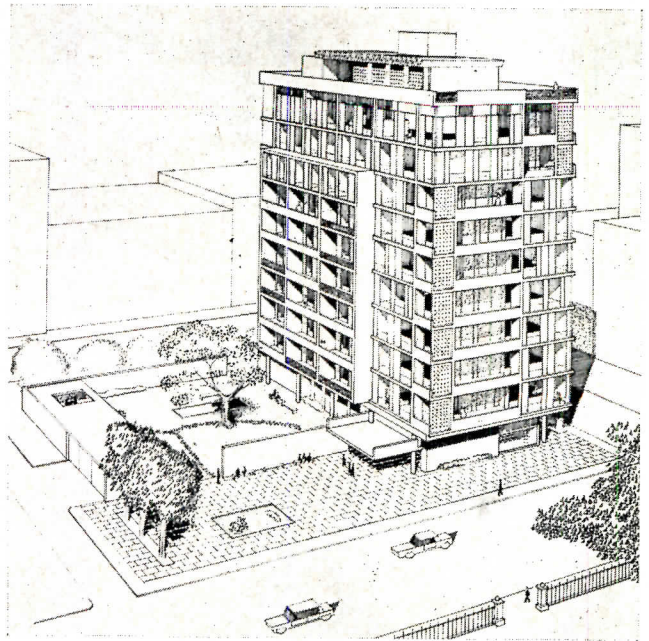

FLOORS 2 TO 7 RESIDENT UNITS

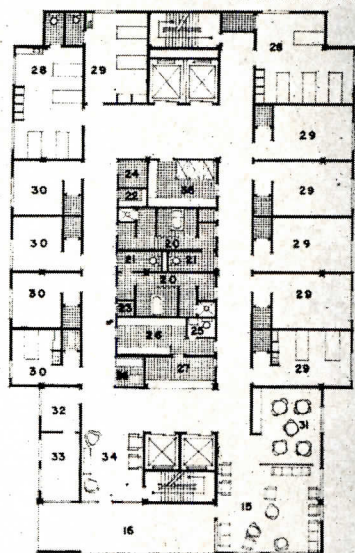

FLOOR 8 INFIRMARY

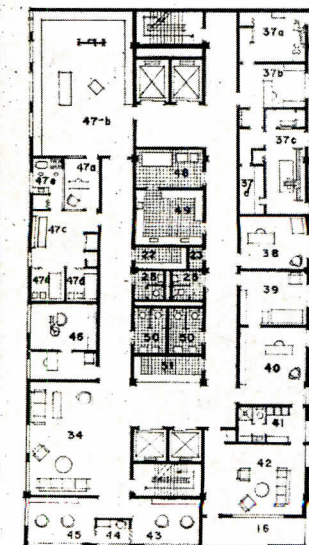

FLOOR 9 HEALTH MAINTENANCE

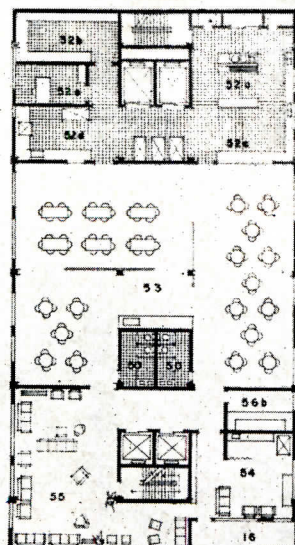

FLOOR 10 MAIN LIVING-DINING

LEGEND

- | | |
|--------------------------------------|-----------------------------|
| 12. Double Residence Room | 38. Eye Ear Nose and Throat |
| 13. Single Residence Room | 39. Exam Room |
| 14. Kitchenette | 40. Doctor's Office |
| 15. Living Area | 41. Doctors Lockers |
| 16. Balcony | 42. Doctors Lounge |
| 17. Sitting Space (5) | 43. Barber |
| 18. TV Area | 44. Podiatrist |
| 19. Resident's Storage | 45. Beauty Shop |
| 20. Bath and Shower | 46. Dentist |
| 21. Toilet (wheelchair) | 47. Physical Medicine Suite |
| 22. Linen | a. Therapist Office |
| 23. Janitor | b. Occupational Therapy |
| 24. Equipment Storage | c. Exercise Room |
| 25. Staff Toilet | d. Electro-Therapy |
| 26. Utility | e. Hydro-Therapy |
| 27. Nurses Station | 48. EKG and BMR |
| 28. Four Bedroom | 49. Laboratory |
| 29. Double Room | 50. Toilet |
| 30. Private Room | 51. Reception Desk |
| 31. Dining Space | 52. Main Kitchen |
| 32. Examination | a. Preparation |
| 33. Treatment | b. Storage |
| 34. Waiting | c. Serving |
| 35. Diet Kitchen | d. Dishwashing |
| 36. Wheelchair and Stretcher Storage | e. Dietician |
| 37. Radiographic Suite | 53. Main Dining |
| a. Fluoroscopy | 54. Library |
| b. Technicians Office and Files | 55. Main Lounge |
| c. Radiography | 56. a. Shop |
| d. Dark Room | b. Coffee Shop |

WAINWRIGHT BUILDING, St. Louis
Louis Sullivan

CARSON PIRIE SCOTT STORE, Chicago
Louis Sullivan

ROCKEFELLER CENTER BUILDINGS, New York
Reinhard & Hofmeister; Corbett, Harrison
& MacMurray; Hood & Foulhouz

LEVER HOUSE, New York
Skidmore, Owings & Merrill

TRINITY CHURCH, Boston
H. H. Richardson

PHILADELPHIA SAVINGS FUND SOCIETY
BUILDING, Philadelphia
Howe & Lescaze

GENERAL MOTORS TECHNICAL CENTER, Detroit
Saarinen & Saarinen

LAKE SHORE DRIVE APARTMENTS, Chicago
Mies van der Rohe

S. C. JOHNSON & SON, INC., ADMIN. BLDG., Racine
Frank Lloyd Wright

MONADNOCK BLOCK, Chicago
Burnham & Root

DAILY NEWS BUILDING, New York
Hood & Howells

TVA NORRIS DAM & POWER HOUSE, Tennessee
Roland Wank, Architect-in-charge

BOSTON PUBLIC LIBRARY, Boston
McKim, Mead & White

STOCK PAVILION, Raleigh
Nowicki & Deltrick

CHRISTIAN SCIENCE CHURCH, Berkeley
Bernard Mayback

WOOLWORTH BUILDING, New York
Cass Gilbert

CROW ISLAND SCHOOL, Illinois
Saarinen & Saarinen,
with Perkins, Wheeler & Will

MANUFACTURERS TRUST BUILDING, New York
Skidmore, Owings & Merrill

UNITY CHURCH, Oak Park
Frank Lloyd Wright

NEBRASKA STATE CAPITOL, Lincoln
Bertram G. Goodhue

S. C. JOHNSON & SON, INC.; LABORATORY, Racine
Frank Lloyd Wright

UNITED NATIONS SECRETARIAT, New York
Wallace K. Harrison & Consultants

LINCOLN MEMORIAL, Washington
Henry Bacon

M.I.T. AUDITORIUM, Cambridge
Eero Saarinen

EQUITABLE BUILDING, Portland
Pietro Belluschi

ALLEGHENY COUNTY BUILDINGS, Pittsburgh
H. H. Richardson

UNIVERSITY CLUB, New York
McKim, Mead & White

CRANBROOK SCHOOLS, Michigan
Ellis Saarinen

MINERALS & METALS RESEARCH BLDG., I.I.T., Chicago
Mies van der Rohe

ALCOA BUILDING, Pittsburgh
Harrison & Abramovitz

MUSEUM OF MODERN ART, New York
Goodwin & Stone

PENNSYLVANIA STATION, New York
McKim, Mead & White

EXPERIMENTAL SCHOOL, Los Angeles
Richard Neutra

DODGE TRUCK PLANT, Detroit
Albert Kahn

100 MEMORIAL DRIVE APARTMENTS, Cambridge
Kennedy, Koch, DeMars, Rapson & Brown

CENTRAL LUTHERAN CHURCH, Portland
Pietro Belluschi

HOUSES

F. C. ROBBIE, Chicago
Frank Lloyd Wright

E. J. KAUFMANN, Pennsylvania
Frank Lloyd Wright

TALIESIN WEST, Arizona
Frank Lloyd Wright

HENRY VILLARD, New York
McKim, Mead & White

WATTS SHERMAN, Newport
H. H. Richardson

AVERY COONLEY, Illinois
Frank Lloyd Wright

W. W. WILLITTS, Illinois
Frank Lloyd Wright

D. R. GAMBLE, Pasadena
Greene and Greene

PHILIP JOHNSON, New Canaan
Philip Johnson

WALKER GUEST HOUSE, Florida
Paul Rudolph

ELLEN SCRIPPS, La Jolla
Irving Gill

WESTON HAVENS, Berkeley
Harwell Hamilton Harris

LOVELL "HEALTH HOUSE", Los Angeles
Richard Neutra

EDITH FARNSWORTH, Chicago
Mies van der Rohe

ONE HUNDRED YEARS OF SIGNIFICANT BUILDING

8: CIVIC MONUMENTS

ONLY TWO OF THE FIFTY buildings named most significant in the last hundred years were designed for the function of government. In a period that witnessed the construction of state capitols all across the country, Bertram Grosvenor Goodhue's remarkable building at Lincoln has been uniquely impressive.

Out of our great federal program of building — in Washington and elsewhere — not a single example was nominated frequently enough to qualify for the list selected by ARCHITECTURAL RECORD's panel.

Local government is represented solely by H. H. Richardson's Allegheny County buildings. This does not so much suggest the inferiority of the efforts of those who proudly erected the courthouses and municipal halls during all those years as it concedes the particular genius and peculiar power of these two architects.

To the foregoing vivid masterpieces of civic monumentality, the panel added the Lincoln Memorial of Henry Bacon in Washington. In this they seem to support the view of so many, both simple and sophisticated, who have found in this great building — despite anachronism and contrary to much logic — a richly satisfying expression of the dignity and reverence in which we hold that man and that concept of a nation to which the building is dedicated.

It has been said that America, in its youth, has not developed a great civic architecture. However, here and there, and most notably in these examples, we may sense that our shortcomings in no way proceed from lack of vigor.

ONE HUNDRED YEARS OF SIGNIFICANT BUILDING

Nebraska State Capitol, Lincoln, 1926, Bertram G. Goodhue (Tied for thirteenth)

“The Nebraska State Capitol is the work of an architect who, steeped in the construction functionalism of the Gothic, worked that functionalism into his conception of a building in a new modern era, whose motto was functionalism.

Its straightforward perpendicular lines have the Gothic reminiscence, combined with the smooth simplicity of the Modern. In color — gold tile dome, blue tile necking below dome, and gold background for the fine Lee Lawrie sculpture — it has a stirring newness. But the building is for the ages, with an excellence and appeal that would make it, I believe, architecture in any era.”

Edwin Bateman Morris

“I have never been in Lincoln, but the nonconformity of the Capitol building by Goodhue impressed me when I first saw it in pictures and, even now, as an antidote against the fatigue phenomena, to which we and all organic beings are subject. A certain habituation, like the endless sequence of domed capitol buildings, simply prevents the vital shock of impressiveness. A basic principle of our own nature, it seems.”

Richard Neutra

Wayne Andrews

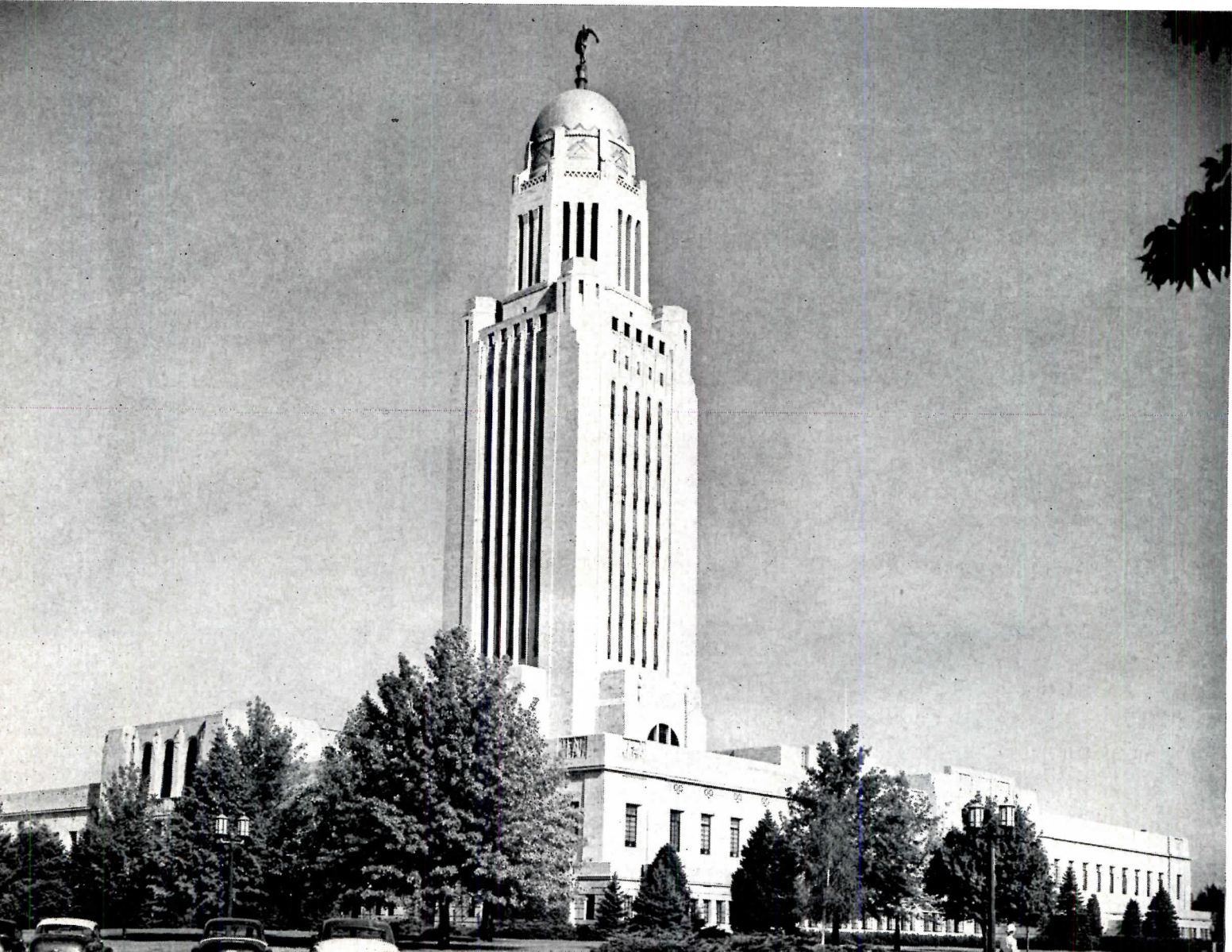



Joseph W. Molitor

*Lincoln Memorial, Washington, 1917, Henry Bacon
(Tied for fifteenth)*

"When I look at and visit the Lincoln Memorial, I have a sense of the most sublime expression of the embodiment of the spirit of Abraham Lincoln that I can possibly conceive. Here are honor and glory and sublime character in a scale which I can identify and which exalts. From every point of view — around and within the building, and from the air and other points of vantage — this building completely satisfies. Of scarcely any other building I have seen, can I express such high praise. If perfect fitness is the highest achievement of the architect, Henry Bacon triumphed here."

George Bain Cummings

"Bacon used the classic Doric with such simplicity that it seemed to epitomize the up-from-the-soil background of Lincoln brought to the acme of refinement by the humility and fortitude of Lincoln's life. The final product of Bacon's work seems effortless. It is a dominating part of the composition of the city. As a termination of the Capitol mall

it is perfect, as a terminal for the Memorial Bridge from Arlington it is no less perfect. Within the simple walls, Bacon created a shrine that is an appropriate setting for the statue of the President who saved the Union."

Arthur C. Holden

"The laurel that crowns a hero is made meaningful by its tradition. It has crowned Agamemnon — and Dante. So it is with the wreath of columns that we have laid around the shrine of Lincoln. They have in them a funded nobility.

That is why this ghost of the Parthenon, pale, impassive, academic — this temple from which the glittering Athena has departed, whose walls bear no longer the gentle knights and maidens, the garlanded oxen, savage centaurs, and serene Olympians — has yet the power to take to itself the reverence and love of a nation.

Shall we ask more of architecture?"

Joseph Hudnut

ONE HUNDRED YEARS OF SIGNIFICANT BUILDING

Allegheny County Buildings, Pittsburgh, 1884-87, H. H. Richardson (Tied for seventeenth)

“Richardson left two masterpieces in Pittsburgh: the small Emmanuel Church in Allegheny, its perfect brickwork sadly neglected, and the great granite mass of a county courthouse and jail wedged in the center of town. Passersby like the jail—dramatically blank except where the jailer’s house appears through wall like a photographic double exposure. Richardson’s victory is the courtyard of the courthouse—a well of space and light staked out by three tall towers. Here the epic of stone is sung by a master poet (Richardson, like Poe, was among the first American artists admired and imitated in Europe), stone appearing in true structural

strength, vaulting and arching in harmonically graded arcades to frame great window areas; quarry-faced blocks lying in courses so precisely proportioned that all seems less weighty, more energetic; intricate shapes that fit perfectly into the overlapping, rising arches of the stairs, the window reveals suddenly smoothed to show a new quality of stone. And not least, those solitary pillars polished as if by use, gleaming jewels set in their rough surrounds, the high C’s of this aria. Richardson never designed a more original or beautiful work than this.”

Edgar Kaufmann

Joseph W. Molitor

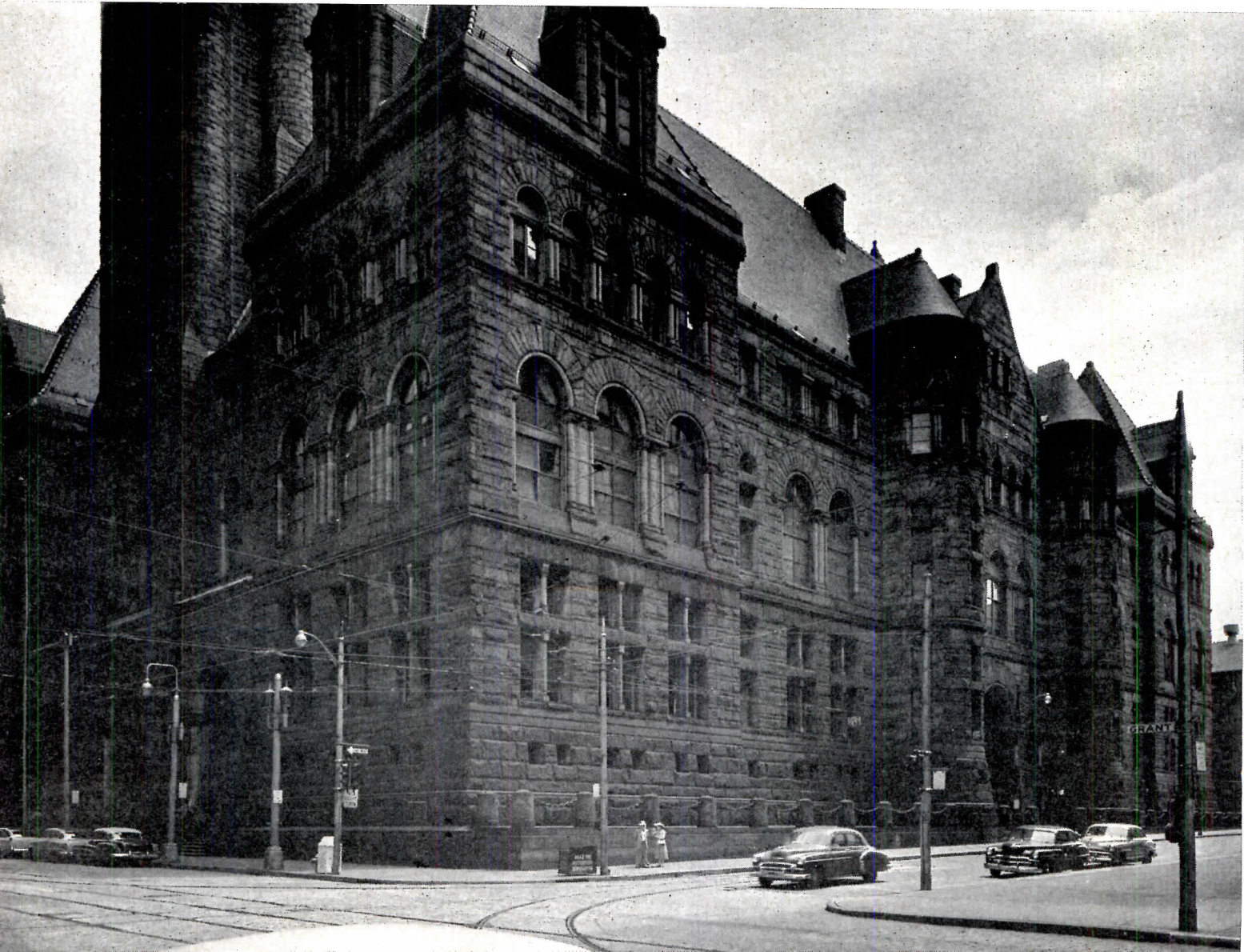

ARCHITECTURE (?) FOR THE NATIONAL PARKS

Mission 66 Program Promises 10 Years of Opportunities and Arguments in the World's Most Wonderful Sites

By **EMERSON COBLE**

WHEN THE YELLOWSTONE AREA was set aside as the first national park, back in 1872, nobody could have imagined the present great park system. Now there are 181 national parks and monuments under federal protection, whose scenic wonders and historic buildings attract more than 50,000,000 visitors a year. In ten years, it is estimated, the annual visitor load will reach 80,000,000. The parks and their facilities are suffering from the familiar troubles of the times, overload and obsolescence and congestion, and a great program of rebuilding is beginning.

If this program promises some opportunities for architects in the world's best building sites, it will also test their abilities and their convictions. It would be difficult to imagine a better background for architecture. But should an architect be tempted toward anything so crass as exhibitionism, he would quickly be put in his place. If he were not sensitive to nature's own admonition to be well mannered, he would be spanked by a veritable host of professionals and volunteers dedicated to protecting the parks against exploitation of the mildest kind. The national parks move their protectors to great fervor, and well they might. This writer, for one, will cheerfully carry his pen like a spear and join the volunteer group.

He will also, however, crusade for better and more imaginative architecture than we commonly associate with national park structures. With few exceptions buildings in the parks seem to run to standard "acceptable" patterns. They have a commendable quality of modesty, some of them are widely admired for an associative rusticity. Some of the greater ones, like the Ahwahnee in Yosemite or the Canyon Hotel at Yellowstone, have grandeur of scale, stylistic quality, and admirable craftsmanship: even if by now their styles are as obsolete as their plumbing. But few, old or new, seem to have the courage of convictions, convictions of any kind. They do not capture or reflect the varied glories of nature, or respond to its magnificence. They do not assert any significant artistic philosophy, or respond to any regional needs. There does not seem to be any expression of native self-confidence, unless it be something associated with a log cabin. In short, the architectural vision in the parks seems to be tightly restricted. It is restricted, currently, perhaps just for the reason that great architecture is so little known in the parks.

To enlarge the vision of architecture is the immediate task; and perhaps it is almost too great a challenge. Perhaps contemporary architects can no more meet it than did those of the past. Or perhaps the most sensitive

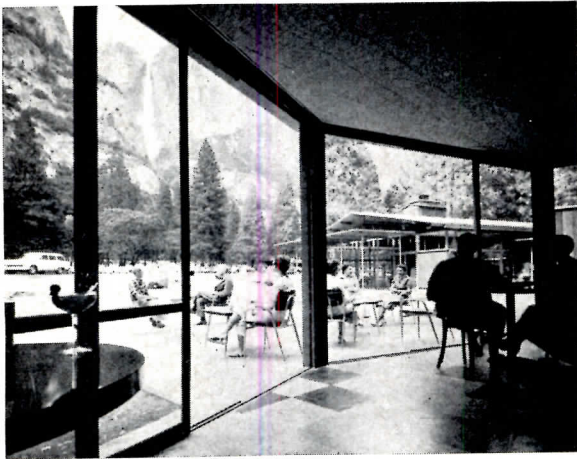

The new lodge at Yosemite; Spencer & Ambrose, Architects

Fifty million people can't be wrong about visiting our national parks — 50,000,000 in 1956, 80,000,000 in 1966. The National Park Service proposes a 10-year program of building facilities to serve the crowds, while protecting the parks from damage or exploitation

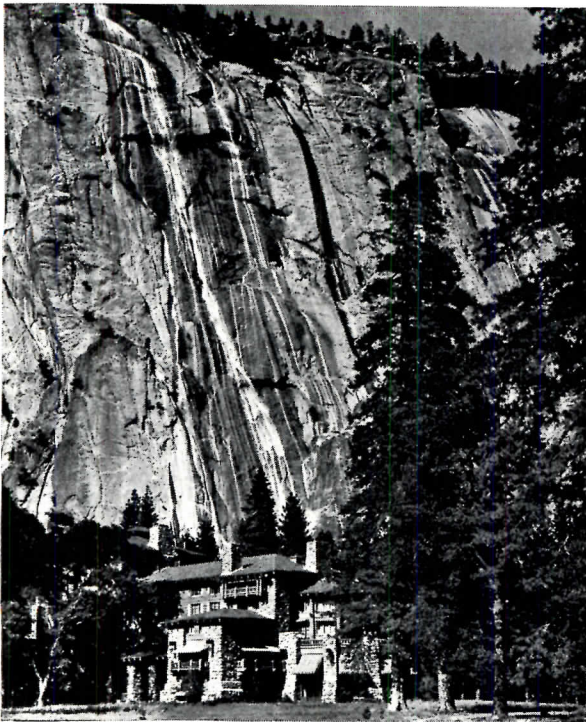

Ansel Adams



Hoynes Studios, Inc.

The older hotels like the Ahwahnee at Yosemite (above) or the Canyon Hotel at Yellowstone (center) with its mammoth lounge (below), obsolete though they may be, stand as a significant commentary on architectural design problems. They challenge architects of today to suggest something to replace their grandeur and scale. They also assert that early architects had no feeling that their buildings were to shrink modestly behind the natural scenery, a notion that now seems to be thrust on architects working in the parks

architectural talent will not get the chance; maybe it did not in the past eras, though the wonders of the national parks ought to call for the best efforts. Certainly no architect can imagine more wonderful sites to work in, a clearer call to make the building an integral part of a larger environment. And never was there such a chance to demonstrate — to millions of captive observers — what great architecture can accomplish. Always providing it is mindful of its manners and its obligations.

ARCHITECTURAL RECORD therefore undertakes a crusade. It would be more accurate to say that we join a crusade, for the national park philosophy has always represented a crusading spirit. We are happy to join in the current campaign of improvement by the National Park Service, known as Mission 66. We join the officials of the park service in all of their stated objectives. If we veer off in some interpretations of our own, we shall be motivated by a conviction that the national parks deserve, demand, the greatest possible architecture, not necessarily the most modest. We shall not be greatly impressed by the virtues of austere economy. We shall not join in any idea that buildings necessarily profane the parks, or in any notion that architecture cannot dare to express its artistic convictions.

We shall probably find occasions to point a prodding finger in many different directions, and likely it will often be aimed at architects.

The Mission 66 Program

The program was initiated by the staff of the National Park Service under Director Conrad L. Wirth, to meet the growing needs of the visiting public. It proposes a ten-year program of rebuilding facilities like public accommodations, information centers and museums, employee housing, roads and so on, along with expansion of service and protective programs in many other respects than building. The hope is that by forward planning and continuous building, the parks can be abreast of, or ahead of, their load problems by the target date of 1966, hence the name of the program.

Needs and objectives are beautifully stated in a letter to President Eisenhower, dated Feb. 1, 1956, by the then Secretary of the Interior, Douglas McKay. He writes:

A critical problem faces our National Parks.

The desire of many Americans to spend their growing leisure in the great open spaces of the National Parks and in visiting our historic shrines has raised attendance from twenty-one million in 1946 to fifty million last year, with eighty million expected by 1966. The result has been an increasingly serious overcrowding of the park facilities: of accommodations, campgrounds, ranger services — everything.

Such a situation endangers the preservation of the parks themselves, and means that many Americans seeking unspoiled recreation and inspiration have been frustrated and inconvenienced.

Our task is unmistakable: to start immediately to equip the National Park System to handle the critical needs both of today and of the future.

Carrying forward Mission 66 will result in improved roads, more campgrounds and facilities for visitor use, and should stimu-

From "My Camera in the National Parks," by Ansel Adams

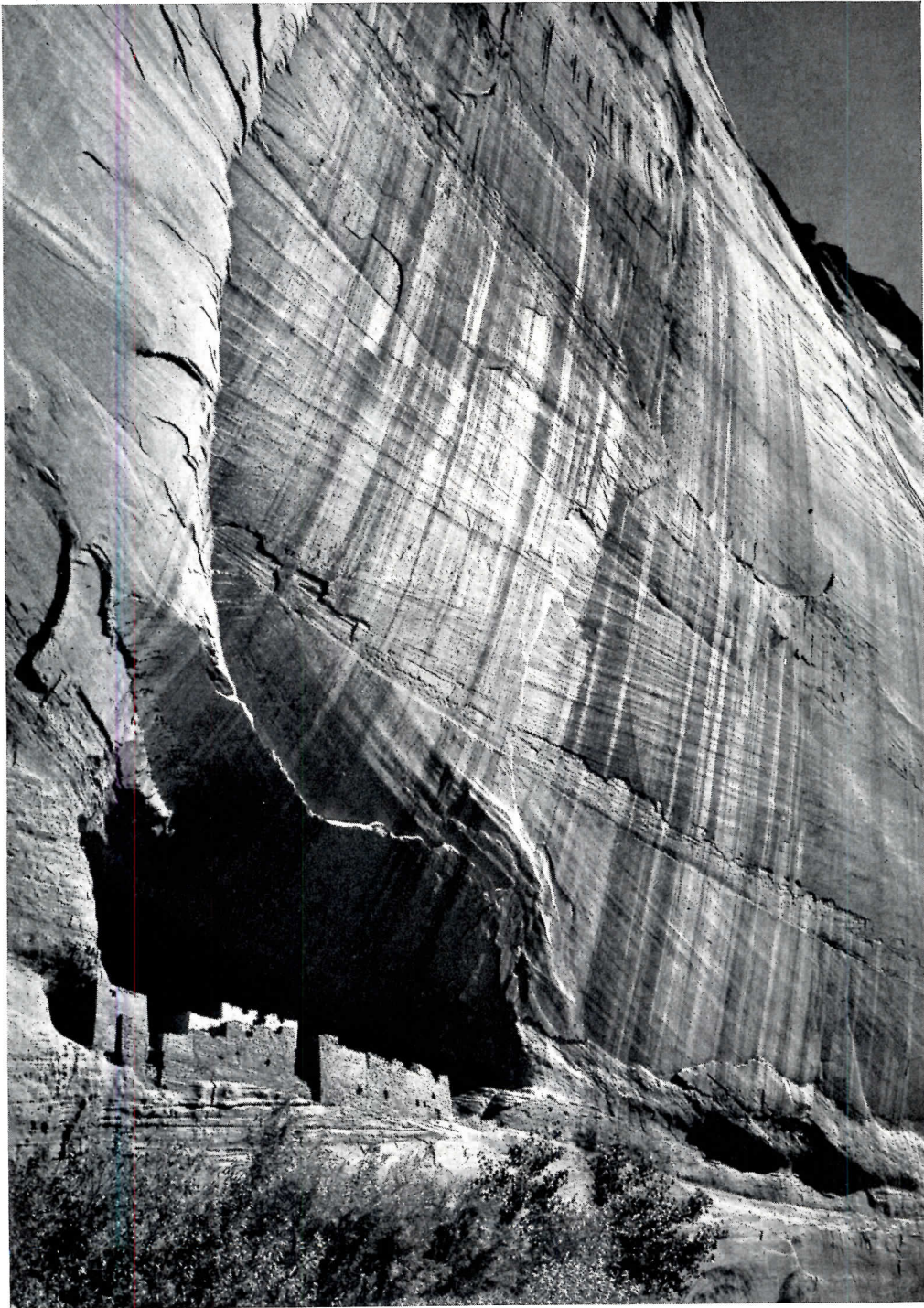

White House Ruin, Canyon de Chelly National Monument, Arizona

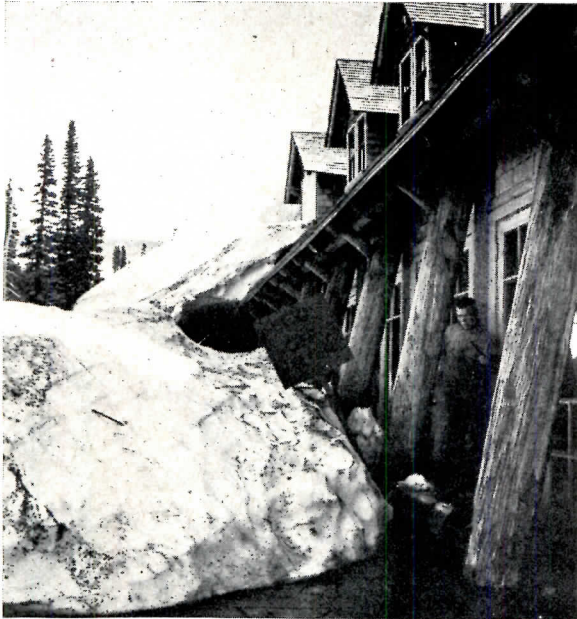

Short seasons in some of the mountainous parks at higher altitudes give the concessioners difficult economic problems; their rates are set by agreement with the National Park Service, but nature sets their business seasons. These pictures were taken in Mt. Rainier National Park on the 11th of July; the snow at Paradise Inn was 108 in. deep

late investment of private capital in modern accommodations. At the same time, it will preserve the historic, the wilderness, and other features of the areas. It will satisfy the demand for more of such ranger services to the public as lectures, exhibits, and guided tours. It will strengthen the Government's partnership with the states, counties and cities in meeting total recreational requirements. . . .

The effort received the enthusiastic support of the President. Congress authorized increased funds for the beginning of the program in 1957 fiscal year. Contemplated for the whole ten years is an expenditure of

\$476,160,000 for capital improvements. It is expected also that private capital will make large expenditures in the parks in various concessioner enterprises, mostly housing accommodations. And the program will encourage more building for travellers on sites outside the parks.

Architects' commissions might come, then, from three different types of sources — the National Park Service itself, for facilities within the parks, to be federally operated; the park concessioners, for housing and other buildings in the parks; private investors, for motels, restaurants, motor facilities and other travel needs outside the parks. Many projects are already planned and under construction.

Attitudes and Arguments

Architecture will be caught in some debates that seem inherent in all matters of national park development. If one assumes that our national parks have been generally well handled, by dedicated people in the park service, one soon learns that the dedicated professionals are pulled and hauled by highly articulate and equally dedicated private citizens. Park service people, both in Washington and in the field offices, speak so continuously of the pressure of opinions that one senses quickly how constantly it hovers over their decisions. Probably the pressure is so effective because it is generally unselfish, wanting mostly to protect the parks against abuse or exploitation.

The desire to protect the parks extends, not infrequently, to the point of saying that there should be *no* buildings in the park — a building is per se a profanity. The national parks are nature's wonderlands, and anything man-made must be an eyesore. This view is deeply entrenched. In some degree the feeling is universal, to the point where any proposal for a building must start with a demonstration of its necessity. People in the park service have long been conscious of the inadequacy of their facilities, but even as they propose the Mission 66 program they must maintain their defenses against purist attack. Every official statement or speech about the program is filled with protestations that the parks are to be preserved and protected. The outside observer, ready to assume the protective intent, wonders at the volume of assertion of the protection theme. He soon learns of the necessity, real or fancied, to justify the need for every comfort station that is proposed. Thus attitudes about architecture base on a foundation of defensiveness.

If this general attitude seems close to incredible in the world of architecture, perhaps some of the architect's insistence on architectural purity would be difficult for embattled nature lovers to comprehend. At any rate, the ban on tampering with natural process is so strong that fallen trees in national parks are not cleared and used; they are left to rot in picturesque fashion. The park superintendent who needs logs for highway guard rails must buy them outside the park and ship them in, even though suitable tree trunks have fallen right beside the road. He might even buy the logs from

From "My Camera in the National Parks," by Ansel Adams



Mount Rainier, Sunrise, from Yakima Park, Mount Rainier National Park, Washington

THE MISSION 66 PROGRAM

1. Provide additional accommodations and related services of types adapted to modern recreational needs within and near the parks, through greater participation of private enterprise.

2. Provide the government-operated facilities needed to serve the public, to protect the park resources, and to maintain the physical plant.

3. Provide the services which will make the parks more usable, more enjoyable, and more meaningful, and thereby improve the protection of the parks through visitor cooperation.

4. Provide operating funds and field staff required to manage the areas, protect the resources, and provide a high standard of maintenance for all developments.

5. Provide adequate living quarters for the field employees of the Service.

6. Acquire lands within the parks and such other lands as are necessary for protection or use, acquire the water rights needed to insure adequate water supplies, and extinguish grazing rights and other competing uses.

7. Institute a coordinated nationwide recreation plan to produce a system of recreational developments by each level of government; Federal, State and local, each bearing its proper share of the expanding recreational load.

8. Provide for the protection and preservation of the wilderness areas within the National Park System and encourage their appreciation and enjoyment in ways that will leave them unimpaired.

MILLIONS OF VISITS

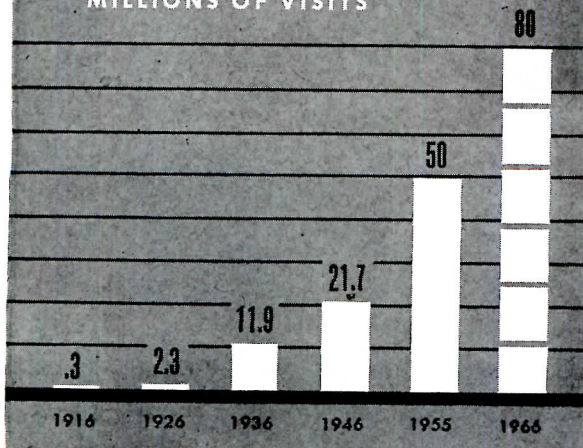

a national forest, where a woods is considered a crop area.

What this attitude has done to architectural design can be seen in one national park where a concessioner's hotel development turned out incredibly badly, largely because of this conviction that buildings are but necessary nuisances. But for that feeling, the great concrete building would not be colored in rustic brown, and most of the guest rooms would not be hidden in a hot low spot, screened from both the breeze and the view. Everybody connected with this enterprise was obviously sincerely intent on preserving the beauty of the scene, but their attitude about the role of buildings has produced a real horror.

People will go to the hotel, will enjoy the scenery, even if that is unnecessarily difficult, but the buildings will do less than nothing to enhance their experience. Buildings are assumed to compete with nature, to distract the visitor from his communion with nature. In this instance the validity of that assumption is strengthened if not proved. If the whole procedure could be exactly reversed, with an opposite result, the opportunity to prove it gets more remote with each such building as this one.

One who is architecturally oriented might protest with all the vehemence at his command that man-made art is not necessarily sinful, that inspired architecture need not be egocentric or competitive, that it might merely add glory of another kind to a high experience. He might make an impassioned speech to the effect that deliberately inane architecture merely panders to the assumed poor taste of the American public, makes no effort to elevate levels of appreciation. The inane architecture might be compared to the junky souvenir business in the parks — if a certain proportion of people want it, that is no reason to make a virtue out of it.

But his oration would fall on deaf ears. The park service literature is full of statements like: "That park buildings be as unobtrusive as possible, harmonizing with their surroundings. . . . In its most satisfying expression, the park structure is designed with a view to subordinating it to its environment, and is located so that it may profit from any natural screening that may exist."

I should like to add that I did not find park service personnel indifferent to architecture, or unsympathetic, or unknowing. They have shown the courage, if that's what it is, to accept the design for a pavilion at Dinosaur National Monument, done by Anshen & Allen and shown on page 186. It is just that they have been schooled in the service in the philosophy that "any man-made structure is an intrusion on the scene." As architects have pointed out, the continual effort to pretend a building isn't there only makes it the more prominent, by guaranteeing that it will not be designed to belong there.

So insistent is this idea of intrusion, both within and without the service, that there is a definite effort in some places, Mt. Rainier for example, to remove the present buildings in the park and just move out. Basic

From "My Camera in the National Parks," by Ansel Adams

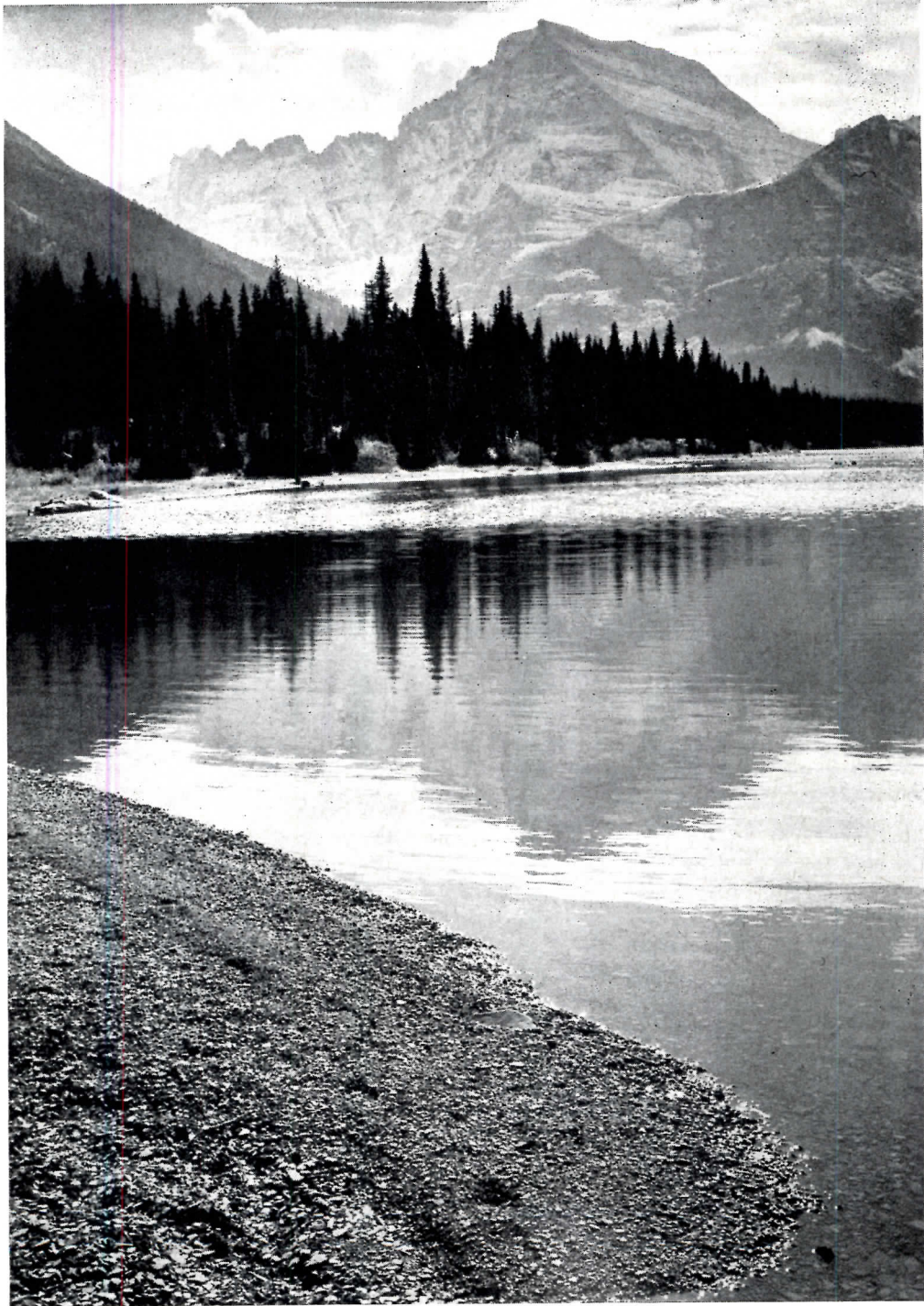

Josephine Lake, Glacier National Park, Montana

theory is that people who want to use the park could be accommodated outside the park and enter it on a "day-use" basis. Buildings, including the staff headquarters, would be razed, and the park returned to wilderness except for roads, trails, parking areas and so on. Implicit in the day-use concept is the idea that most people are to drive in, take a quick look, photograph the mountain, and be on their way. If they don't get their fill in one day, they can return the next. They are not to be allowed to stay overnight unless they are woodsmen enough to camp out; somehow hiking, climbing and camping are natural parts of the enjoyment of the park, but sleeping in a hotel bed up in Paradise Valley is not quite cricket — that is using the mountain for resort purposes. Incidentally, Mt. Rainier has been the center of a great battle, and the issue of cost and profit has much to do with it, and perhaps this park is not the best choice to illustrate the day-use principle. Mt. Rainier might be a good example, however, of the extent to which the idea of buildings contaminating a park has been put forward.

The resort idea was once the accepted concept of visiting the national parks. The great hotels of 40 or 50 years ago, some built by railroad money, offered grand accommodations to entice the visitor to the park. He arrived by train and stagecoach, and stayed for a considerable length of time. The visitor was, of course, supposed to be attracted by the park's wonders, not by the activities at the hotel.

Of late, however, the hotels seem to be in progressively less favor. People now come in their own cars; they want motel-type accommodations, or camp grounds; they take one snapshot of Old Faithful, and are on their way.

Naturally these habits of the times are taken into account in the new accommodations being planned. The private car, however, leads to the purist thought that the visitor should sleep outside the park boundaries, that the park itself might be kept free of buildings for sleeping. Now such an idea is not, of course, suggested for a park like Yellowstone, which is nearly 100 miles wide, but it does represent a current climate of thought for many a smaller park.

Official thinking runs, in any case, to the short-stay concept of park visitation. Park staff personnel point to the obvious fact that the visitors set this pattern of park use, not the staff; park people are inclined to deplore that pattern, saying that it is rubber-neck sight-seeing, not participation in an inspirational or regenerative contact with nature. On the other hand, there seems to be suspicion of the participation concept if this involves a lengthy stay in a hotel-type accommodation. The true hotel is suspect on the ground that it creates resort attractions. Accordingly present hotels are tightly restricted as to attractions they can offer.

As for buildings, this sort of thinking leads toward a concept of accommodations that is interesting. It is in effect a combination of motel and hotel — motel in cabin or row-type sleeping rooms, hotel in dining and lounge facilities. So the public part of the hotel is built

as a lodge building, which is surrounded by cabins or cottages. It is an exploded hotel, in reality. If its economy is not apparent, it is at least informal. Since it requires more land it does take a larger bite out of the park than a hotel would.

Similarly camp grounds and trailer parks require a great area, a larger area than hotels of the older day. In this respect the extension of such facilities in the Mission 66 program runs counter to the purists' cry that the parks are over-used and over-developed, though, as previously said, camping does not seem so objectionable as more concentrated use.

In all of these matters, the dilemma is, of course, the conflict between mass use and letter-perfect protection of nature against spoilage. It is frequently pointed out that the act of 1916 which created the National Park Service put this dilemma in official language: ". . . which purpose is to conserve the scenery and the natural and historic objects and the wild life therein and to provide for the enjoyment of the same in such manner and by such means as will leave them unimpaired for the enjoyment of future generations." It is increasing use that makes that statement seem like two objectives, not just one. In 1916 nobody could have foreseen that in 40 years attendance at the parks would have risen to 50,000,000 a year.

Mass use is, then, both the reason for Mission 66 and the cause of concern to the protectors of purist persuasion. NPS personnel want to expand facilities but not too much. And there is a neat question as to where to draw the line.

The line is already drawn, and rather firmly. This observer rather formed the habit of asking a naive question, "Is the program big enough?" At first this was merely the natural question one asks about all planning for the future, since seldom has "master planning" had big enough eyes. Later it became rather a "dirty question," always sure to provoke a flinty answer. The answer wasn't always the same, but it tended to have a positive tone.

A spokesman for one of the volunteer groups said firmly, yes, indeed, it was big enough. There was evident satisfaction that more was not planned, and an implication that any more would be fought to the death.

Another voice spoke from the wisdom of long years of service and said, no, it was not nearly big enough. Facilities in the service had always been operated on a patchwork basis, still were, and, judging by the program proposals, always would be.

And the voice of Horace M. Albright, a retired national park service official of over 40 years service (whose prestige in the parks "approaches the awesome," as one observer put it): "I think that any appraisal of the extent to which the primitive values have been protected by the National Park Service should be measured by the estimated 97 per cent or more that is still undisturbed, and not by the things that have happened to the very small percentage that has undergone intensive development for public use. Mission 66 is astonishing on the point that it plans so little expansion

From "My Camera in the National Parks," by Ansel Adams



Jupiter Terrace, Mammoth Hot Springs, Yellowstone National Park

of roads and development of new areas. However, assuming that such areas do comprise 3 per cent, and I am sure that it is not more than that, can't we afford to raise this to 5 per cent without bringing in the spectre of national parks with their natural values impaired or destroyed?"

It is a fact that great areas of some of our larger parks are completely undeveloped, are almost never seen by man. Only a small part of the 10,000 thermal phenomena in Yellowstone are accessible by road; two great geyser basins lie in wilderness areas accessible only by horseback. Yellowstone is almost as large as the state of Connecticut; no new roadways have been built since 1908; none are now contemplated; there is still room for some tramping around. As for over-use, Mr. Albright says that only two areas — the eastern section of Yosemite and the Old Faithful region of Yellowstone — are seriously over-used. If concentrations of people waiting for the Firefall or Old Faithful bother people who are themselves part of the crowd, who is to blame? Can we generalize on that basis that the national parks are over-used?

As presently drawn, Mission 66 does propose to do something about the needs of the crowds, about better planning for crowds, but it doesn't propose to invite the people into still unopened areas.

Money, Money, Money

Money matters are not supposed to raise their heads in the academics of the parks, but they are no more

One of the insistent headaches of the National Park Service is housing for park service employees. This row of trailers is employe housing at Grand Teton National Park; new permanent housing is, however, under construction in another part of the park. The staff housing problem, never an easy one, is made more difficult as park use expands, and information, protection and safety needs mount also



easily banned from the circle than in any other interest. And money matters a great deal when buildings are discussed.

Any buildings to be built by concessioners — and the park service is always trying to spur the concessioners onward — are based on the unfortunate necessity of private capital to earn a profit. The concessioner, of course, has a monopoly in his park, and it is easy to conceive of him as a Shylock preying on the citizens. NPS records do not indicate that any great wealth has been accumulated here, and most of the concessioners do not show great eagerness to rush in with new funds for investment. The concessioners are controlled by the park service. They can do in effect only what they are allowed to do. Their rates are established by agreement with the service.

In many parks the really tough problem is the shortness of the season. Snow may block roads and cover buildings until late June or early July; it will be coming down again in September. The combination of short season and controlled rates may well be an impossible one for an investor.

Now comes the question of how the problem is best answered. Should society say that there will be accommodations only where the season-rate equation comes out satisfactorily? Or shall we say people should be allowed to see the parks at reasonable cost, even though the economics don't come out right in the federal treasury? In short, is it right or wrong to think of subsidy?

Actually federal economics in the parks are quite loose, all along the line. Everything the park service spends in the parks is budgeted and authorized as so much down the drain. The nominal amounts collected for entrance fees or such like go into the federal treasury just like income taxes, with no credit to their source. The parks are an expense, and the service is not accustomed to "living it up"; it is more accustomed to struggling with budgets long since outmoded.

Theoretically, wherever policy dictates that there should be facilities for the public to use, even hotel rooms, there is nothing to prevent government money being used to provide it. But administrators are not prone to suggesting that private concessioners be helped out financially; it has been done, will be done again, but just doesn't sit well.

This correspondent is merely reporting at this point, not urging that Uncle Sam start throwing money around in the public parks. I might, however, point out mildly that requests for the whole service, Mission 66 construction included, range from \$66,000,000 in 1957 to \$83,500,000 in 1966. These are millions, not billions. It just happens, one notes, that the total government expenditure amounts to about \$1 per year per visitor. This particular taxpayer would like to think he was getting similar value for every other dollar he pays, or, for that matter, every other \$10.

Architecture in the parks runs up against another dollar matter which is quite common in all government work. A private architect who wants to plan buildings

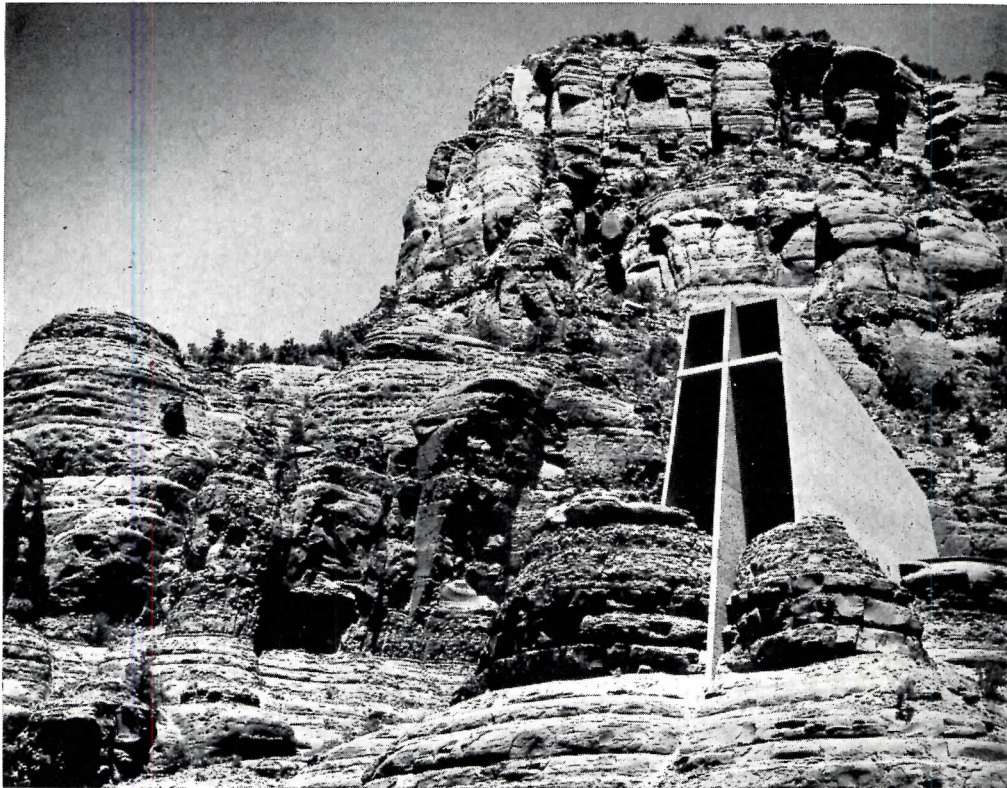

Julius Schulman

Chapel of the Holy Cross, Sedona, Ariz., Anshen & Allen, Architects



Church of the Transfiguration, Moose, Wyoming

for the park service (not concessioners, at this point) must bid for the work on the basis of fees charged. Or, to turn it around, the park service must give out work to private architects on the basis of the cheapest quotation for design work. This taxpayer would have no hesitancy in telling Uncle Sam how stupidly he is spending my money in this sort of bargaining.

Do we hire singers on the basis of the lowest bid? Or sculptors? Or movie actors? Or even government administrators?

But when it comes to architects we do try to get service on a bid basis. We don't pay for vision or imaginative or creative ability; we pay for so many hours of drawing work. We don't need to inquire, then, what we get for our money.

The park service has two regional design offices, one in Philadelphia, one in San Francisco. They do programming, planning, building design, with staff architects on the service payroll. Presumably they do the building design for the service's buildings in the parks. They may give out some of their work to private

Increasing visitor loads in the parks are the stimulus for new building activity outside the boundaries as well as inside the parks. This playful little restaurant with its hyperbolic paraboloid roof is not exactly typical of highway buildings, but we can present it hopefully. It is the Rock 'N' Pines Lodge at Estes Park, Col., Ralph D. Petersen, architect. The restaurant building is executed in wood, and was built for less than \$25,000



architects, on the basis of overload or of special service desired or any other basis. But the architect who gets the work must bid for it.

This sort of operation, it would seem, gets honest, capable, sometimes devoted service. But it certainly is not calculated to tap the best talents of the country's most brilliant creative architects. Rather it would just have to tend toward the safe solution. A few great architects might dig hard for the chance to work, strain their abilities and their time to produce something forward and great, then fight for their ideas through all manner of bureaucratic questioning. But nobody believes this to be the usual result of this kind of governmental penny-pinching. Incidentally, of course, nearly all governmental services work this way; nearly all governmental services get honest plodding in their building designs.

Now if we really don't want any architecture in the national parks, but merely want to hide our constructions behind the trees or the hills, well, all right!

But nobody means we don't want architecture. Nobody even says it. What they say is that if we must have buildings let's have good, safe, sentimental rustic stuff that everybody associates with natural scenery. They say architecture must be unobtrusive, must speak in hushed whispers. People are to commune with nature, not with architecture. Architecture is not to commune with nature. Architecture is not even to help people commune with nature.

Well, all right, maybe we are getting too involved here. Maybe, when we speak of architecture assisting in appreciation, we are thinking of architecture of too high an order. Maybe architecture, generally speaking, isn't that good. I shall have to insist, however, that nobody can accept the latter idea just out of hand. Let us not decide, just because we cannot draw it on the back of an envelope, that the great and sympathetic architecture cannot exist. I shall have to insist that the effort to achieve or acquire great architecture has almost never been tried. The whole habit of thinking in the parks is the other way. We have not dared to let man design in the parks; we have not asked to see what he might do. We have slapped his hand and told him not to try anything.

It Can't Be That Bad

If this picture begins to sound dismal, it really is not as bad as I have painted it. I have waved my sword around rather dramatically to urge a serious look at the long-time policy of hiding our buildings in the shrubbery.

However we decide that question, we shall still see a great rebuilding program in the parks; architects will still try, as they always do, to make their work have significance and validity, to make them do something to enrich the human spirit. In the parks the human spirit will be ripe as never before for enrichment, and we shall hope and believe that, at least here and there, architecture will add something to the nobility of nature in her most exalted moods.

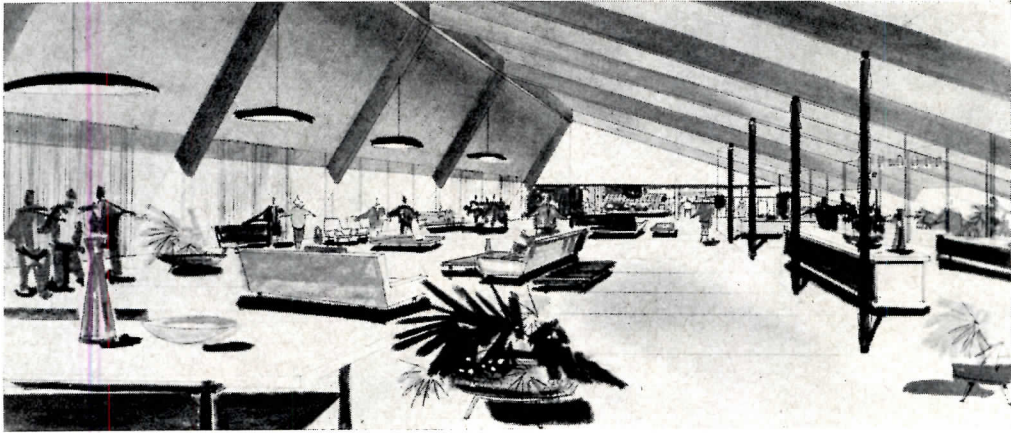

Interior of Lodge Building, Canyon Village, Yellowstone Park; Welton Becket and Associates, Architects

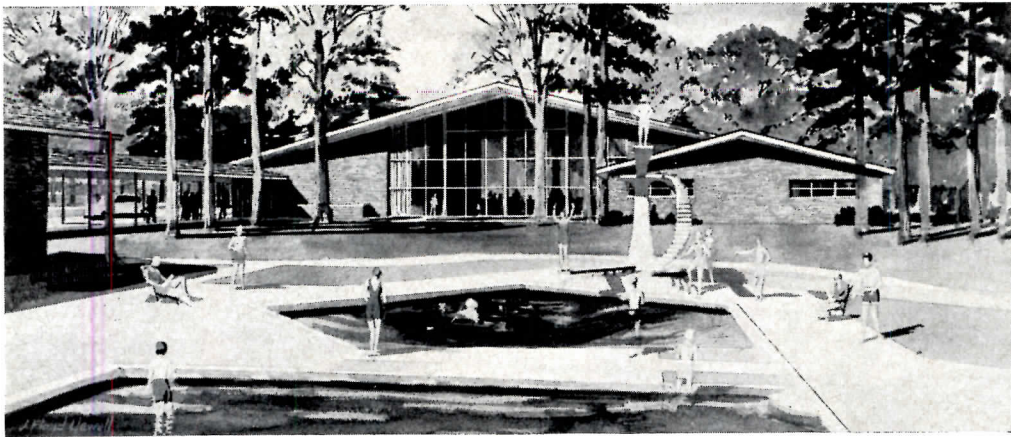

Cafeteria Building, Colonial Williamsburg Information Center; Harrison and Abramovitz, Architects



Herb Povinall

Coller Bay Development, Grand Teton National Park; Spencer and Ambrose, Architects

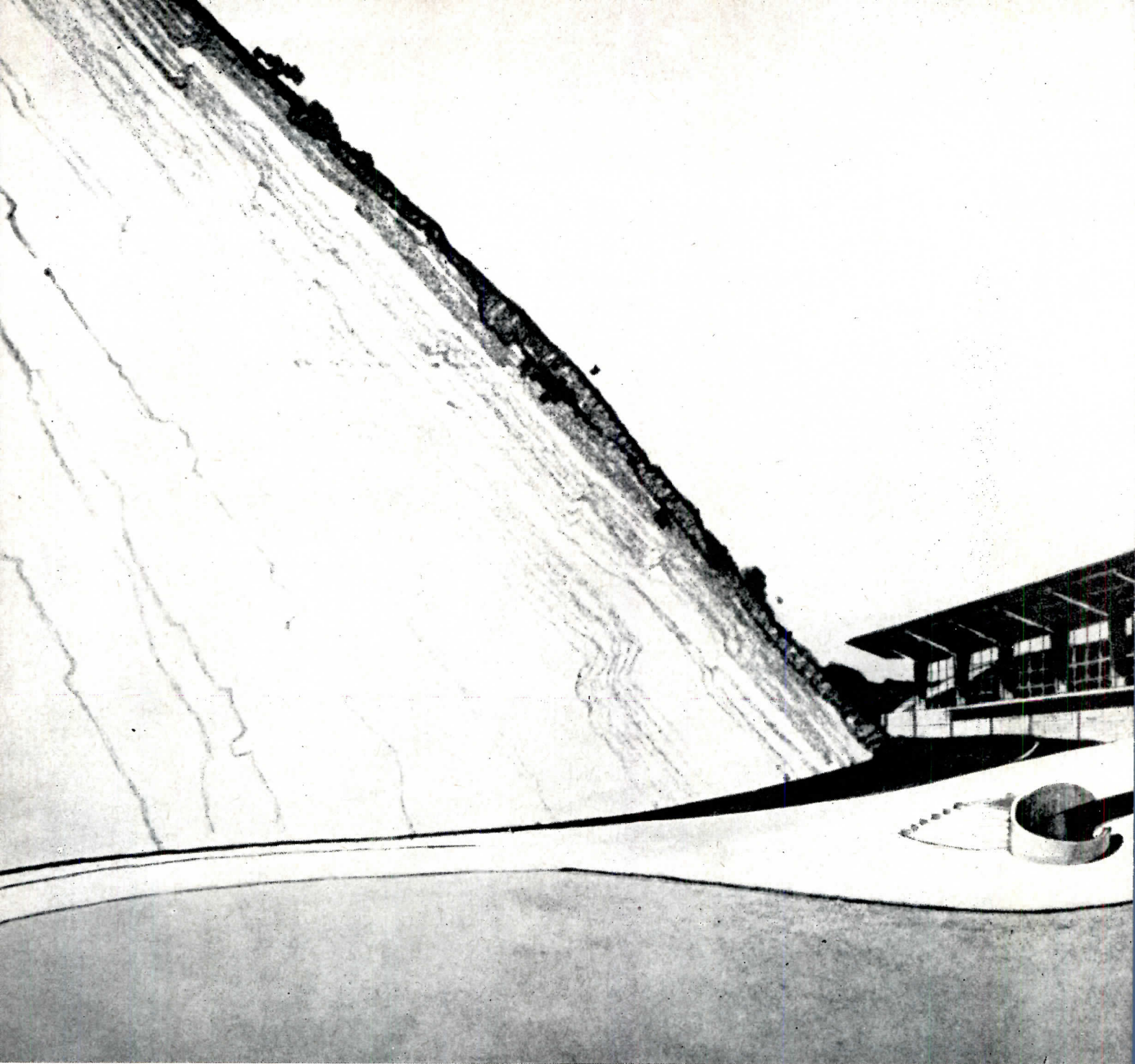

VISITOR CENTER FOR DINOSAUR NATIONAL MONUMENT

*For National Park Service
Anshen & Allen, Architects*

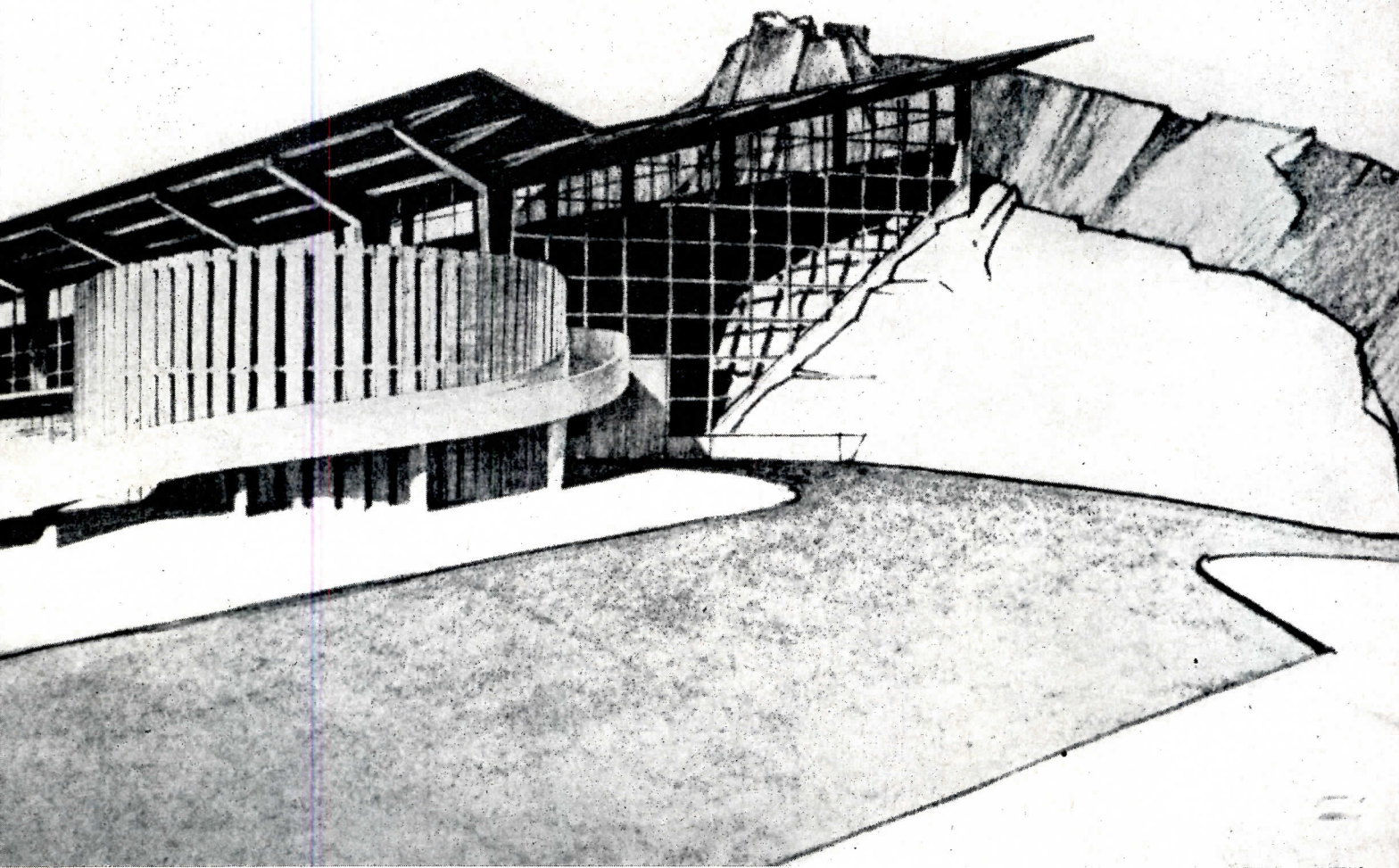

ALREADY THE AUTHORS of a most stimulating and satisfactory building in one of our National Monuments (Chapel of the Holy Cross, Sedona, Arizona, ARCHITECTURAL RECORD, October 1956), architects Anshen & Allen have now designed an arresting and appropriate visitor center to house an "in-place" exhibit of America's largest deposit of dinosaur fossils.

These are in the fossil-bearing cliff face which forms the north wall of the otherwise glazed shelter protecting the exhibits and the continuing archeological work. Everything here has been done with great respect for the nature of the setting. The roof profile fits the slopes of the valley walls; its overhangs protect from direct summer sun; a maximum of daylight is saved for the

exhibits; and a minimum of interior-exterior visual interruption allows the fossils to be seen in their natural surroundings. The pleasant curving ramp leads the visitor to the two-floor lobby which is heavily enclosed to provide a strong transition from outdoors into the glass pavilion.

Although there is, in the sketch above, an invitation to read the slit openings in the circular masonry block element in terms of conventional window widths and to get an impression of a change of scale in this portion of the building, its eventual realization in three-dimensional space and in real materials will be, hopefully, in complete harmony with the rest of this exciting and excellent architecture.

VISITOR CENTER FOR DINOSAUR NATIONAL MONUMENT

*For National Park Service
Anshen & Allen, Architects*

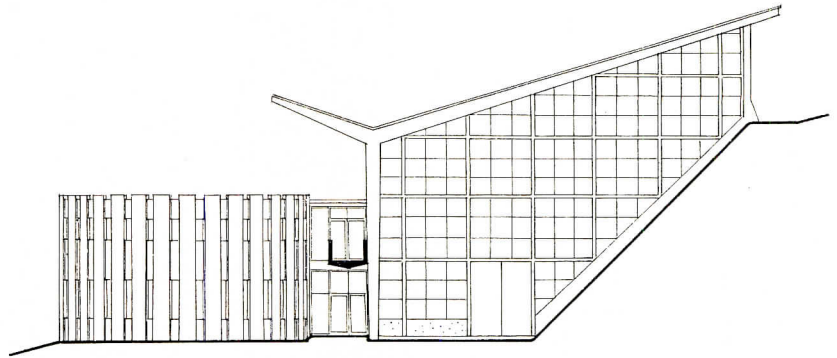

EAST ELEVATION

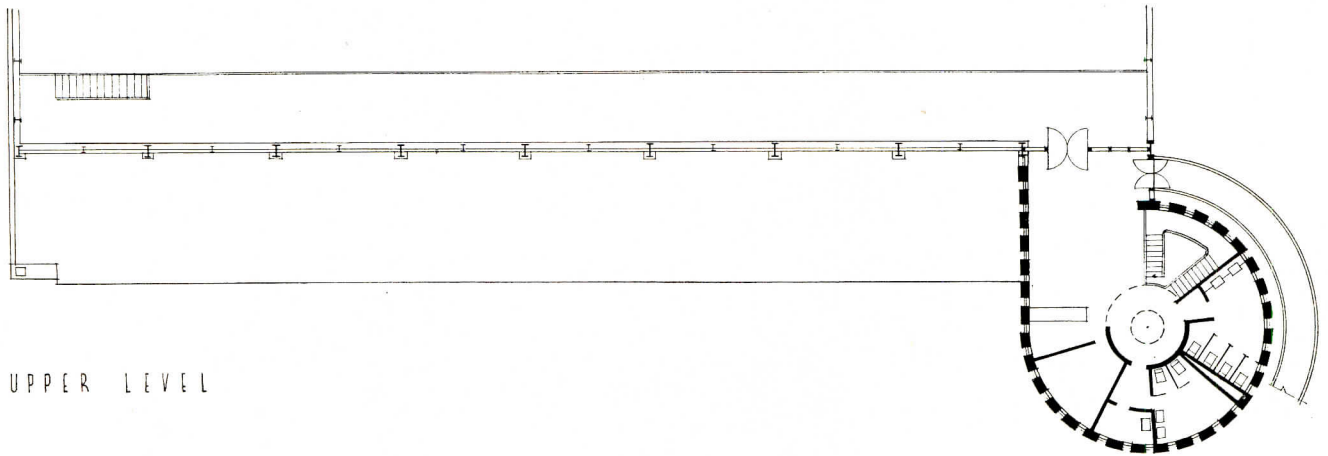

UPPER LEVEL

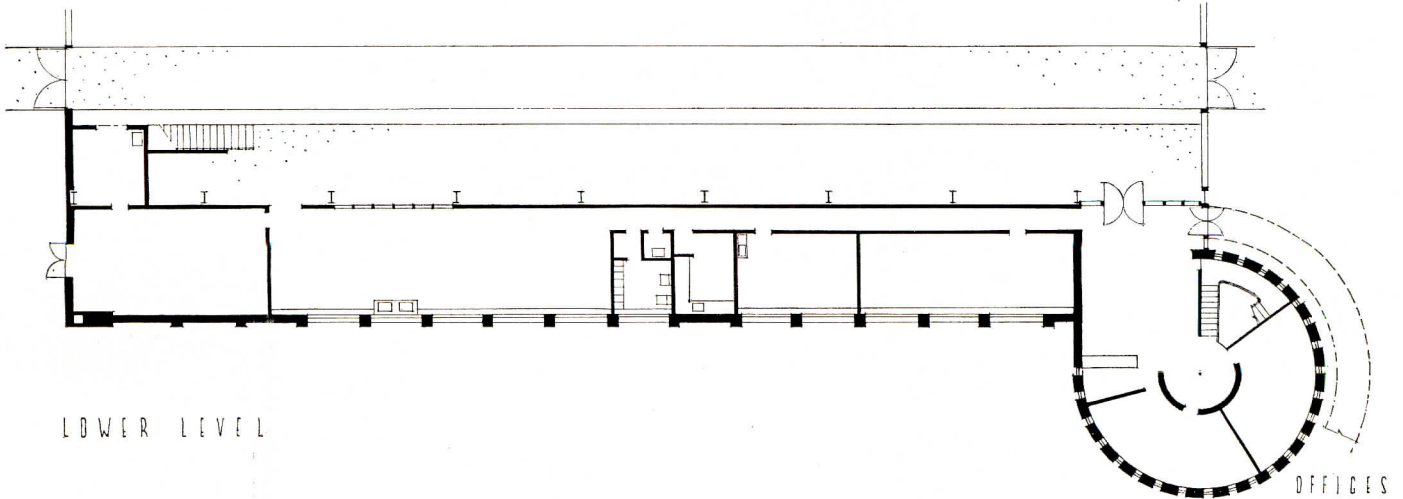

LOWER LEVEL

OFFICES

The Problems of School Sites

By Frank G. Lopez, A.I.A.

THE PRACTICAL DIFFICULTIES that site conditions raise are of course of great importance, and they carry considerable weight in determining which of the available sites for any given school plant may be the best. However, there are other factors, many of them not to be assessed in terms of dollars and cents, which have an equal though not always recognized importance in both selecting a site and making the best use of it. Among these are possible use of the site to further the educational aims of the school, some of which may not be tangible; the nature of the microclimate and use of natural features to enhance or control it; and such imponderables as community feelings or emotions, the expression of the hopes of citizens and educators both, the relation of the school complex to other aspects of a master plan for an area, and many others. We shall discuss as many of these as space permits in the following pages, and illustrate them with several case studies.

In size school plant sites have for years been growing. The shift of population in America, an accelerating movement out from urban centers to peripheral areas and from the country to the same peripheries of cities, has helped bring to reality this concept of a large amount of acreage for each school, so the necessary buildings can be low and spread out rather than massively — and to children, oppressively — vertical. Not that a large vertical structure is either necessarily oppressive or inefficient; it would seem, rather that our architects have not yet found out how to design a big building in such a manner that it will be warm and friendly. In theory, quite a good case can be made for the concentrated vs. the dispersed school structure. In practice, as far as educational efficiency is concerned, many multi-story school buildings have

excellent circulation between their various areas (for circulation can be as direct vertically as horizontally) and often the long distances between units of the sprawling “campus-planned” school are the very opposite of efficiency, educationally speaking.

It is in quality of design that the large vertical school structure seems lacking — or, to state it more directly, in esthetics. We have blamed this on our architects, but perhaps this is not entirely fair, perhaps the fault lies in the educator’s dogmatic insistence on small scale, on one-story schools, on developing all the small bits of a school complex almost independently of each other, with little regard for their resolution into a unified whole either as a functioning organism or as an architectural entity. Perhaps we should at this point find fault with our architects for having surrendered to others so much of the thing which is their special competence: the ability to design, to design both the whole and all its parts.

However this may be, our school sites must, educators tell us, be very large. In some urban places, for instance the Sunset community development in San Francisco, it has been possible to devote acreage rather than square footage to educational plants. In others, where intensive land use and population density forbid, school sites are obviously restricted and restrictive; sometimes, as in New Orleans, buildings are raised on stilts so even the ground occupied by the buildings can have outdoor usage, and often flat rooftops are turned to the same purpose. Educators and architects alike cudgel their brains to find ingenious means of obtaining non-existent outdoor square footage.

For schools the urban scene thus presents grave site problems; urban conditions are at odds with educationally

SCHOOL SITES

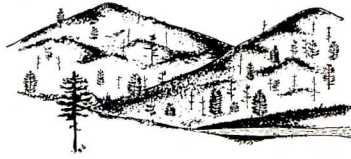

accepted criteria as to area, nature and location of school sites as well as with the nature of building design considered appropriate. The high cost of urban land is the obviously dominating factor, but others inherent in the way our cities have developed have almost equal force. As the suburban school problem has multiplied its needs have overwhelmed and thrown into obscurity such lesser problems as the city's. There are those who say our cities are dying and so their school difficulties can be forgotten. It is true that many of our cities need re-organization and even extensive remaking; but the very nature of our industrial economy demands the city as a focal point for population, as a center of business activity, for the distribution of the goods we manufacture and ship and advertise and sell in increasing quantity to an increasing populace. Our fashions in clothing, our cultural centers, more prosperous than ever as our material wealth increases — theaters, art shows, concerts, the important libraries and publishing houses, etc. — originate in our cities and remain city-oriented. Many brains theoretical and practical are currently at work on the problems of urban rejuvenation. We have the beginnings of legal forms for the purpose, our economic leaders are beginning to understand the importance of making our cities function again for an order different from that which gave them birth, we have a few examples of actual rebuilding.

Pittsburgh's golden triangle, Philadelphia's efforts, the re-housing developments in St. Louis — these and the few others like them have been in the newspapers. Vast schemes for Chicago, Washington, New York and Boston, that would have excited ridicule only a few years ago, are now viewed with less public scepticism. But we prefer

to cite a lesser example though one not grandiose and hence not generally known — and possibly of greater significance than those which excite fanfare — a series of incidents in Charlotte, N. C. Some years ago, as we reported in a recent issue, Charlotte embarked on an extensive school building program because its population was growing; like most American cities, the physical growth was outward toward the periphery and was accompanied by evidences of interior decay. The new schools were planned for the periphery. Many were built. The existing centrally located schools, it was believed, could be converted to other uses. Businesses and light industry were taking over the city center, where housing was deteriorating. The pattern is familiar.

However, Charlotte's school authorities found they could not do without their central schools; on the contrary, these had to be modernized and kept in use. Possibly because of the city's prosperity, possibly because industry began to establish itself just outside the city limits, possibly because of these and several other factors combined — for instance, perhaps because the new peripheral schools siphoned off population and so left central residence areas vacant at prices that were quite reasonable — central city dwellings began again to fill up, the new occupants began to take reasonable care of their new-old homes, and their children had to have schools. Although little definitive research has been done to determine the precise whys and wherefores, it is fairly certain that long-range school planning and site selection exerted a strong influence.

Yet the suburban school site is the largest problem because suburban population has grown rapidly and continues to grow. Fortunately land is still often

available in suitable locations and at a cost the suburban community can afford. However, as the suburbs close in this is less and less likely to be true; advance planning, reservation of school sites and even greater use of powers of condemnation would seem essential to forestall future difficulties. Some communities are now at work in this manner; all should be. Surveys of present and potential school population, and projections of residential development to determine desirable school locations, are a starting point. The services of state departments of education, of competent school consultants and of our colleges of education are available for these purposes.

Some years ago in a few states a program of consolidation of rural school districts was undertaken. The objective was to improve the quality of public education in rural areas by improving the facilities and permitting greater efficiency of operation, increased variety and quality of instruction, etc. This program is continuing and has spread to most states until, in one form or another, it is an almost universal American practice. Site problems for rural schools have been of a different kind than those of city or suburban schools. In the country land is generally easily available, though its acquisition may also be difficult since the rural pocketbook is tight; there is not as much money to spend.

When the practical problems of site development are examined it can be seen that there is no site that is really impossible if it is large enough and if enough design ingenuity is expended. Some of those which once might have been called unbuildable have become the locations of some of our best school plants. While it is manifestly undesirable to complicate design by selecting a

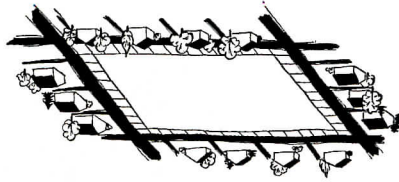

poor site in preference to a good one, if some drawbacks must be accepted they can usually be turned to advantage.

A site good from many points of view may be rocky, hilly, wet, odd-shaped, unduly small, climatically difficult, heavily wooded, etc. There are ways to overcome all these difficulties, and in the overcoming to create an educational jewel. Is there likely to be considerable rock excavation? The school may be built as a series of small cottages, residential in character, connected or not as climate and local preference decree, and demanding little excavation. A sharply sloping site? The school may be multi-story in some parts, single-story in others; it may be projected over covered play space; it may, again, be dispersed in a number of small units. A rolling, hilly site? Once more, dispersed units, connected or not, with the connecting passages ramped to fit the contours, are appropriate; so also are variations in story heights.

Wet sites are considered more difficult. Drainage trenches, or channeling of wetness to form a pond — which can be well used for educational purposes — or the use of fill for play areas provided investigation shows that some land more suited to building exists within the site's limits, are among the solutions. Some of these devices are expensive; often the expense can be thoroughly justified. The odd-shaped site, too, requires thorough study of the problems of circulation between buildings and to outdoor areas; and yet admirable results have been achieved by utilizing an odd shape as the basis for creating successive vistas, injecting into the design at little cost beyond the designer's time those elements of surprise and pleasure which are so satisfying.

The problems of the small site we have touched upon in the preceding dis-

cussion of urban schools. To repeat, the utmost ingenuity must here be employed to provide sufficient outdoor areas, and to provide within the buildings substitutes for unavailable outdoor space.

Climatic difficulties have strong influence indeed on the nature of the buildings, their distribution on the site, and the development of outdoor areas. The direction of prevailing winds is important because at some seasons it can be utilized to improve natural ventilation within the school building, while in other instances and at other times, protection against wind-borne storms is essential. The prevalence of dust, wind, rain, sleet and snow storms needs also to be taken into account. The intensity of the sun, building and playfield orientation with respect to the sun, the desirability of permitting or excluding insolation, etc., intensely affect school plant designs and cost. Average daily temperatures during the school year are similarly controlling factors.

In respect to cold climates, an interesting speculation, about to be tried out in practice, has been reported from Maine by Alonzo Harriman, architect, of Auburn. He has found that, even with all the insulation that it is economically desirable to install, school buildings in his cold climate lose quantities of heat through floor slabs laid on grade, quantities sufficient to keep the ground around the building clear of frost and snow during the worst winter weather. He now proposes to turn this phenomenon to practical advantage: to build a school without any insulation against heat losses through the ground, and since foundations will thus not be subject to frost action, either to omit foundations entirely or keep them to an absolute minimum; the floor slab will virtually "float," a practice once

thought practicable only for regions not subject to freezing weather. His preliminary calculations indicate that fuel consumption should not be unduly increased. However, the theory has yet to be put to practical test.

And there are many, many ways in which the school site, its selection, development and subsequent use, is both affected by and in turn affects, the nature of the community of which the school is a part. To take just two of the schools illustrated in the following pages as examples, the school in Knoxville, Tenn., and the school in Kellogg, Idaho:

No one can prove statistically what the Knoxville school will do for its community. Certainly the provisions for integrating handicapped children into a normal educational atmosphere, as far as possible, is intended to make of these unfortunates as good citizens as their handicaps permit. The effort to accomplish this should alone improve the emotional status of the community's adults who are their parents as well as of the children themselves; it should create hope and purpose. The way in which the small, steeply sloping site, a none-too-large city block, was turned to advantage to further this educational purpose is admirable. Knoxville is all hills, it is true, and so the good use of difficult land by Knoxville architects is not too surprising. But considering many times elsewhere we have seen school sites bulldozed and filled and tortured to create "level" building area, it is well worthwhile to call the Knoxville school to attention.

In the example of the high school at Kellogg, Idaho, are epitomized many of the points here enumerated and many that have been only implied. As the senior high school for a newly consolidated Class A district it serves what

were formerly a number of Class B districts; it is a recent example of the type of consolidation for the improvement of facilities that has been previously described. Its location is just outside the town limits, which is appropriate since it serves several communities. Immediate access from a principal highway, because its pupils come from points scattered widely over the 400 square mile district, whence they are transported by bus over the region's few narrow roads, was one determinant in site selection. Yet the school is far enough from the highway to obviate traffic hazards.

The site had also to be selected and the building designed — with a view to minimizing the effects of severe climatic conditions both natural and man-made: winds, storms, smoke and dust nuisance, water supply, extremes of solar heat and winter cold. Any site available near Kellogg, where a thorough survey indicated the school would be best situated, was bound to present difficult topographical and soil conditions. The site chosen, like the others, was unusual in shape and a water course traversed it; it contained little level land for outdoor development to say nothing of buildable area. It was mountainous, not just hilly; it had water problems; it was rocky — in such a mining region rock is not merely a commonplace, it is the source of livelihood.

Admittedly the site at Kellogg is extremely unusual. On one side the rugged Bitterroot Mountains in which to hunt and fish; on the other, profitable, man-made ugliness. The way in which both have been employed, the use to which land that was, to say the least, unlikely as a school site has been put, the resulting lift of the spirit that it is giving to the people of Kellogg — these should help other architects who face site problems hum-drum or equally dramatic.

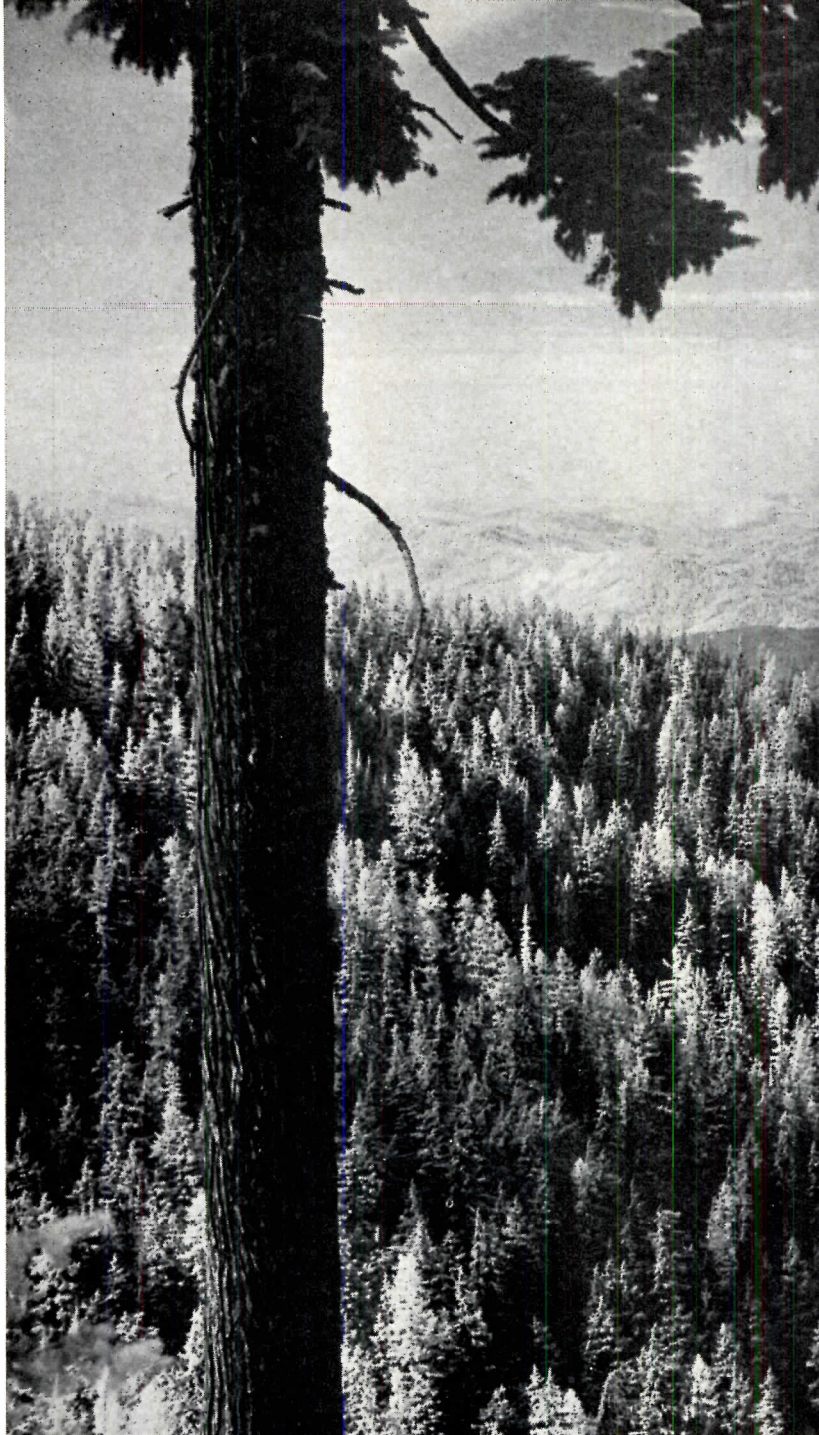

Billy H. Hope



Hedrich-Blessing



Kellogg High School, Kellogg, Idaho. Architects: Culler, Gale, Martell & Norrie; Perkins & Will. This is the land as it once existed, rugged and forest covered, throughout the Bitterroot Mountains in Idaho's northern panhandle. This is the country from which come a rich share of the names familiar to devotees of adventure novels, names such as Jacob's Gulch or Jackass Creek. This is mining country; Kellogg is in the heart of the Coeur d'Alene district, on the river of the same name. Lead, zinc and silver are mined in Kellogg, a town that grew up around the mines

and plants of the Bunker Hill and Sullivan Co. — in other words, a western counterpart of the familiar eastern mill town.

It is easy to understand that satisfactory sites are rare in such an up-and-down country; the valleys where the roads and railroads run, with the scattered towns strung along them for communications' sake, are scarcely wider than their river beds; floods are not unusual; Kellogg occupies a wide spot in the valley of the Coeur d'Alene. But it is not only ruggedness that characterizes the town site. Around Kellogg the mountains look

SCHOOL SITES: KELLOGG, IDAHO



Ben Hoessler



Hedrich-Blessing



Billy H. Hope

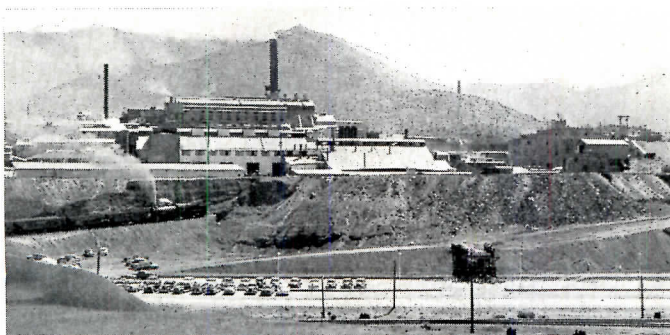

Billy H. Hope

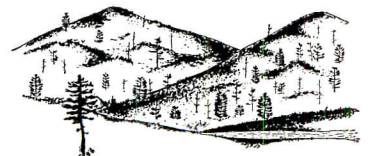



scorched, mauled, and Kellogg itself — though it is clean and well kept — is approached along U. S. Highway 10 past scarred, barren patches of mountainside, past great mounds of black slag and sandy, rocky mine waste, often under a haze of gray smoke from the stacks of the huge smelters that overlook the town. The smelter fumes have killed vegetation, have prevented regrowth of timber burned in a forest fire almost 50 years ago.

These evidences of physical blight were until recently, paralleled by company control of much of the town's economic life, by restriction (through

company ownership of land) of its expansion, by company competition with local merchants, by the fact that the principal company properties were outside the town limits — which restricted its tax income. Evidences of company generosity to the town were many, but these were always recognized as gifts. At the same time, local incomes have been rising; Bunker Hill employs about 2700; its payroll is about \$14,000,000 annually; about 40 per cent of Shoshone County's population is in the \$4000-\$7000 income bracket (national average, 30 per cent). Since the people

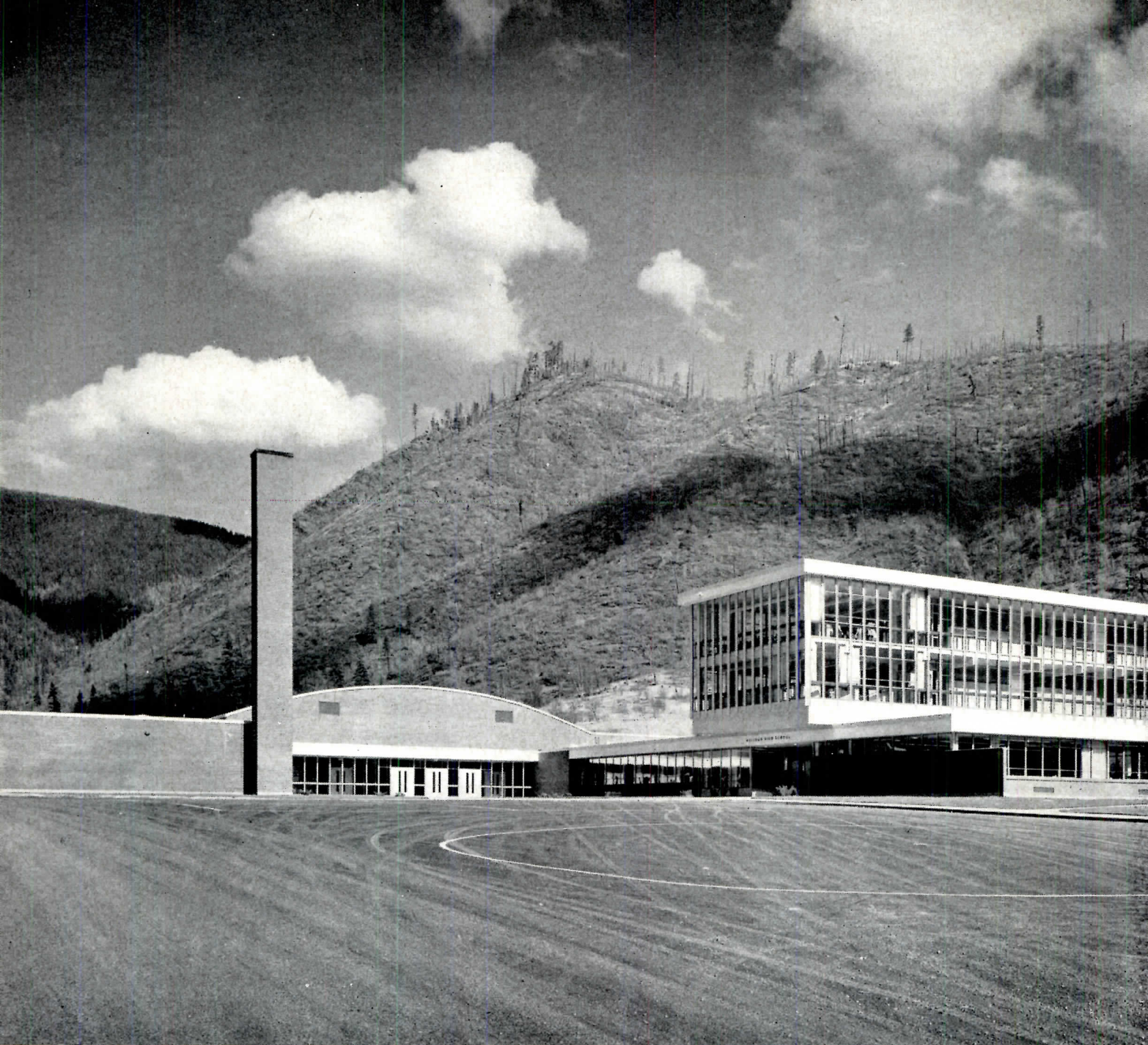

of Kellogg are well-to-do, they have the interest, time and money to support enthusiastically a yearly concert series, to cite one of several cultural indices.

A short while ago the company shortened its name to the Bunker Hill Company, began its own internal reorganization, began an orderly expansion — and completed an about-face in respect to its relations with the town of Kellogg. It has ceased competing with local merchants, has begun to reduce the smelter-smoke nuisance (finding profit thereby in the sale of sulphur products),

has sold some land and has agreed that its plants should lie within the expanded municipal limits, which has about doubled Kellogg's tax income.

Kellogg High School is almost a symbol more real than the phoenix. It is a realization of hopes. It is also the result of long, careful planning for which Superintendent Howard Andrews and Dr. J. F. Weltzin, dean of the University of Idaho College of Education (who was called in to survey needs), and the Kellogg Board of Education deserve joint credit. Andrews, a native of Idaho, approached his job with ideas and with zeal.

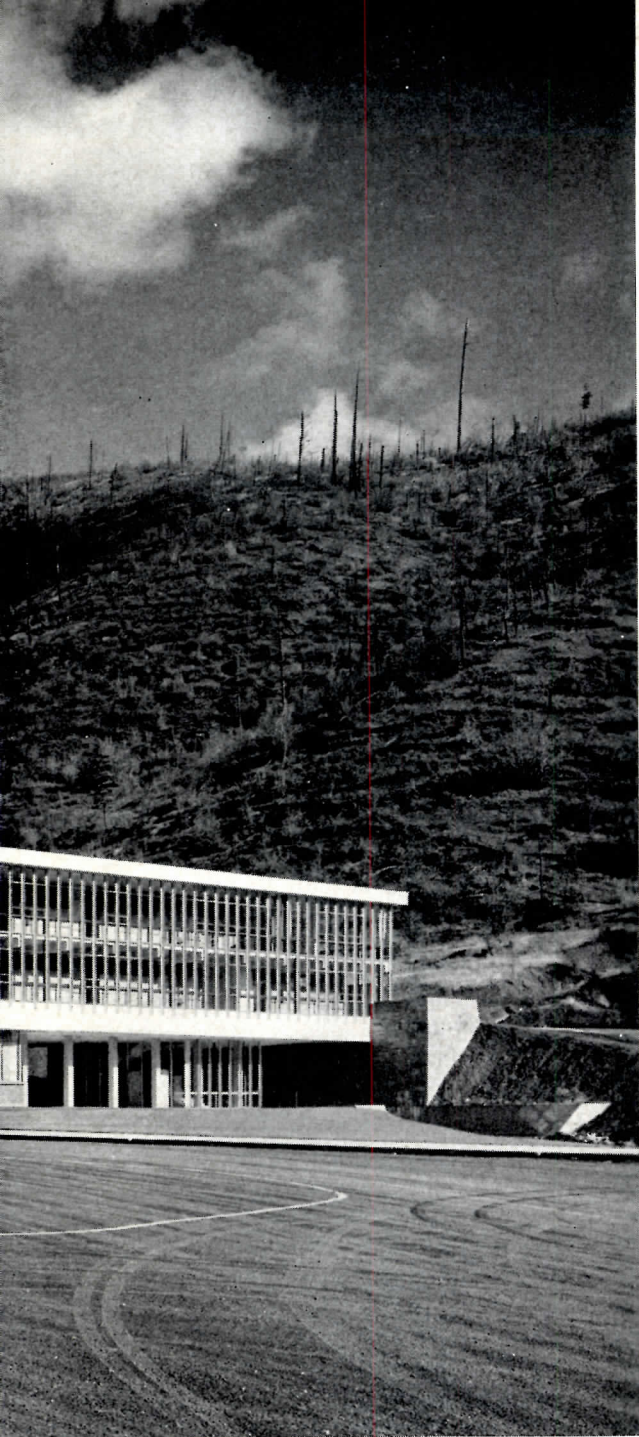

Hedrich-Blessing



Billy H. Hope

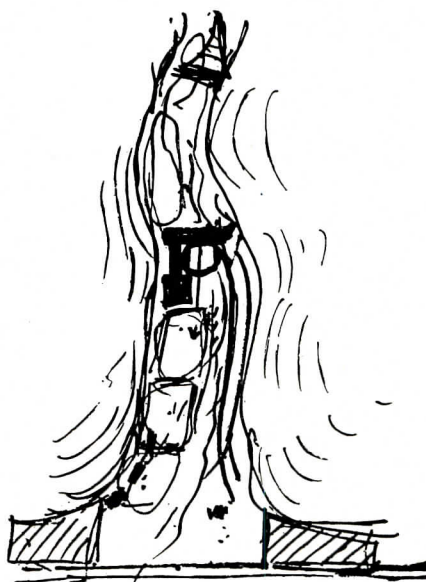

Original sketch plan

Topography

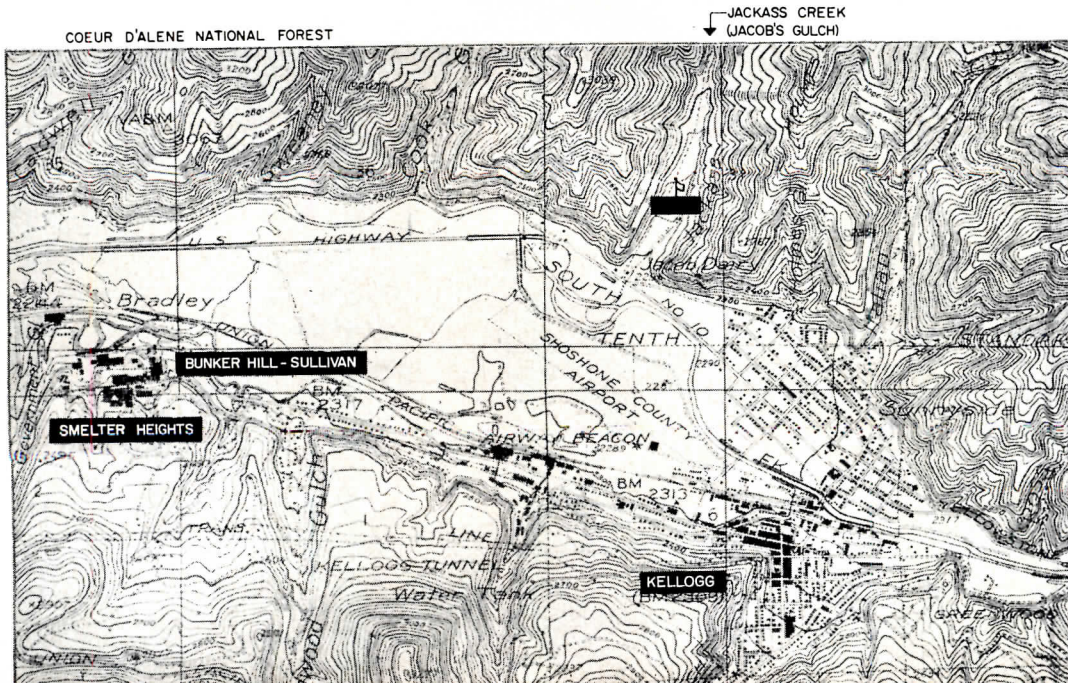

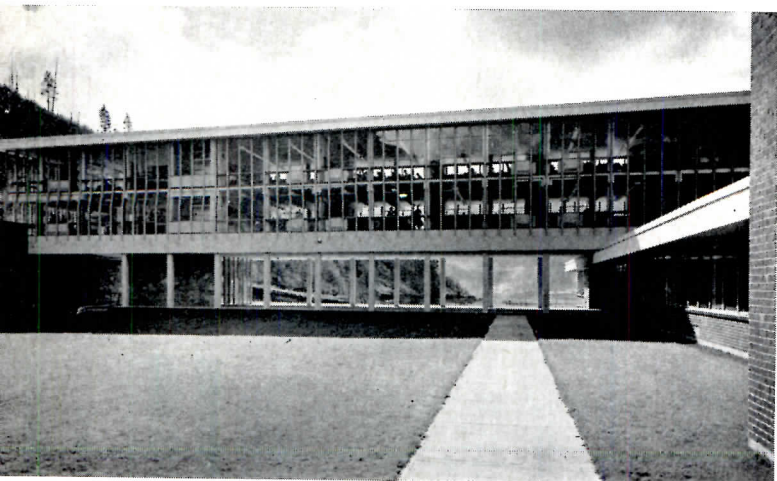
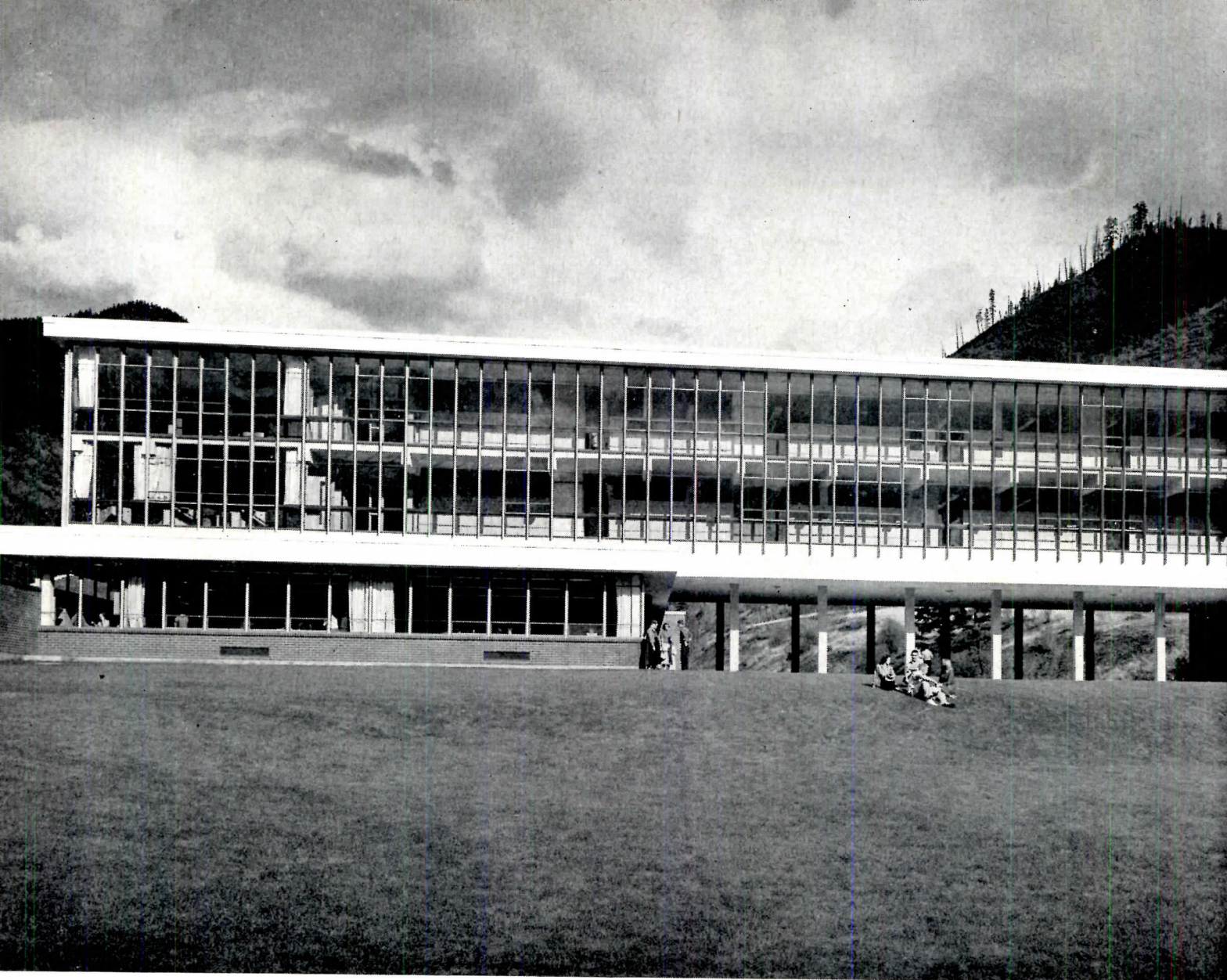

Hedrich-Blessing

Among other things the Weltzin survey recommended consolidation of six small, independent districts, a change from an 8-4 grade system to a 6-3-3 system, and the location of the senior high in Kellogg. It took five years for the Superintendent to achieve consolidation. Then began selection of the site.

Of five possible sites, the best was Jacob's Gulch, down which Jackass Creek runs, because the land conformation sheltered the gulch from wind and dust storms, because its elevation minimized flood problems, because the mountains' cut

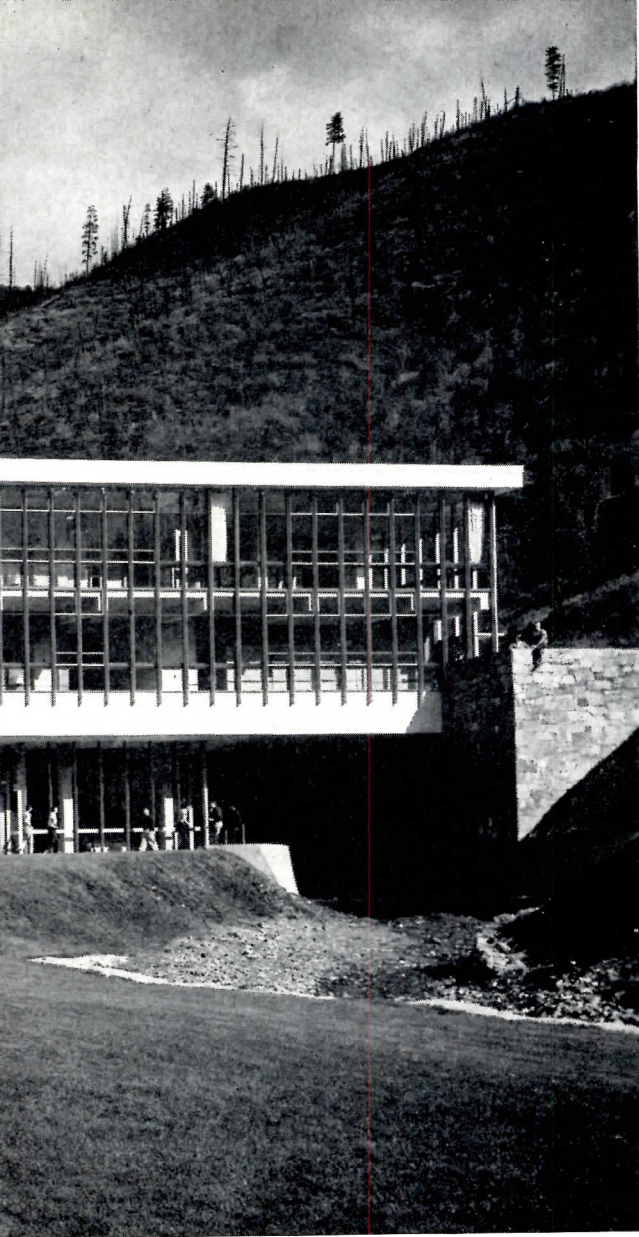

Hedrich-Blessing



Billy H. Hope

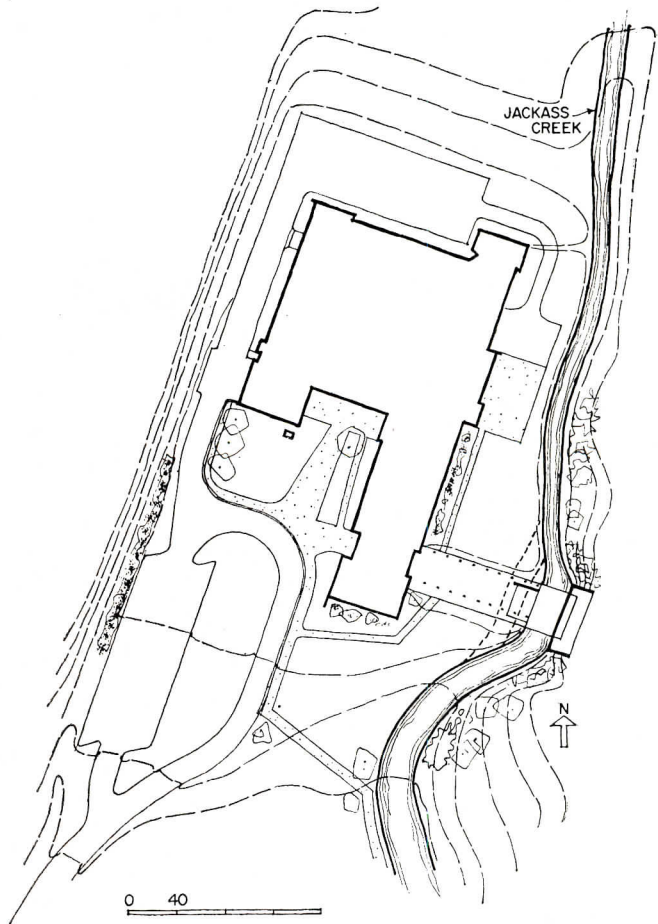
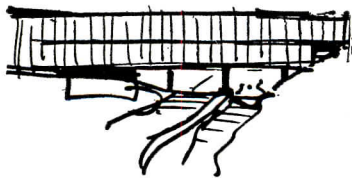
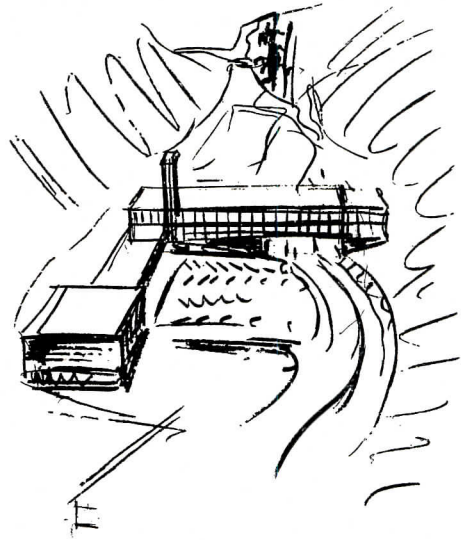

PLOT PLAN

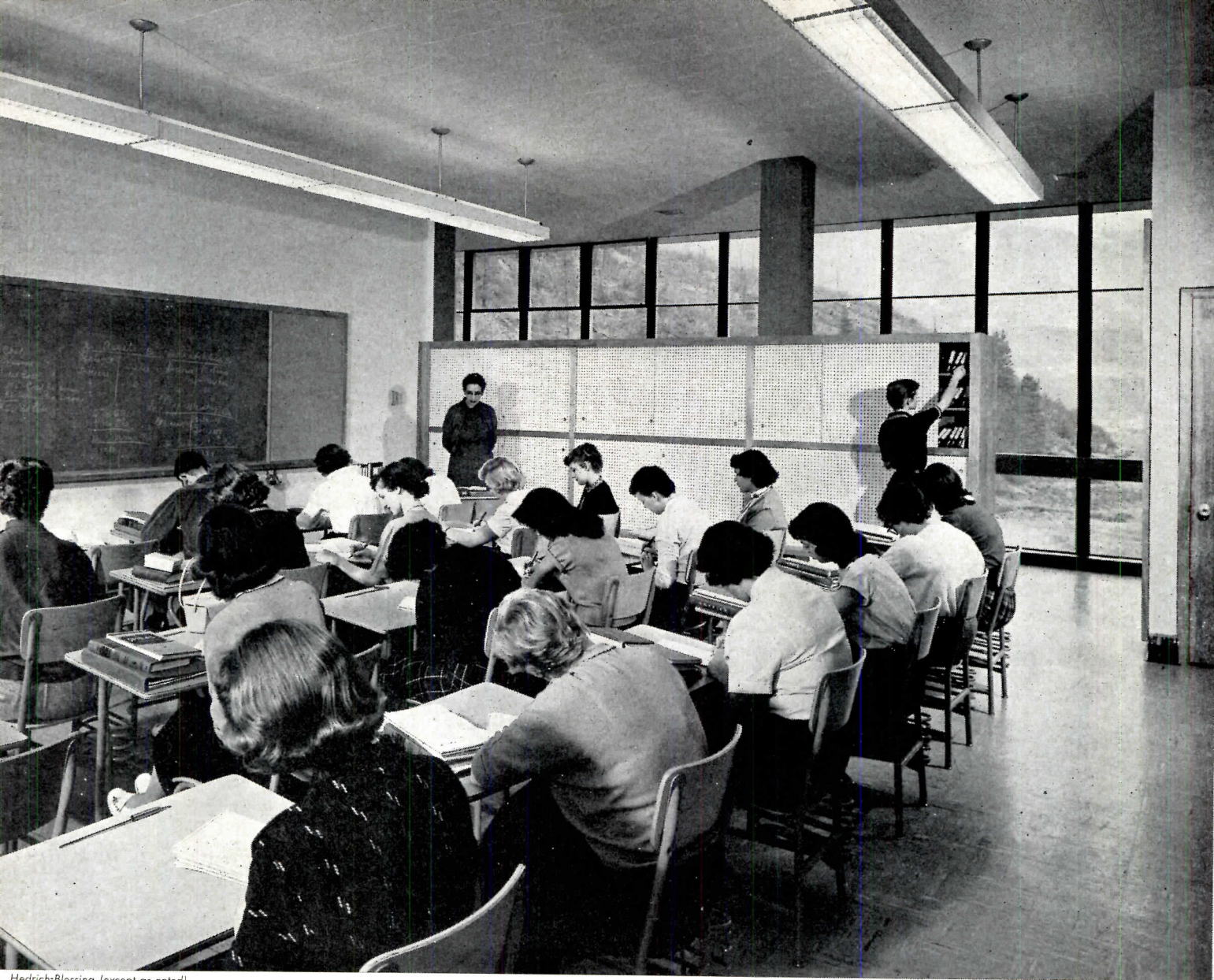

Hedrich-Blessing (except as noted)

solar heat, because by damming the creek a permanent, low-cost water supply could be obtained. From the first, as the original roughly drawn sketches show, it was conceived that the creek should run right under the building; there has in fact been little deviation from the crude scratch-pad drawings that were drawn for a Board of Education meeting.

Superintendent Andrews' enthusiasm made it evident to the architects that Kellogg must have a high school that would epitomize civic pride and so help the town in the process of lifting it-



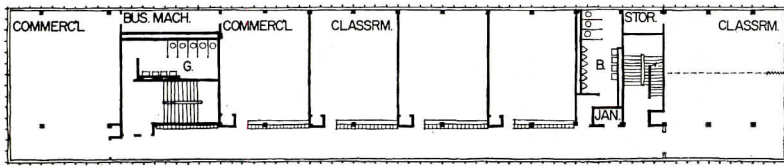

THIRD FLOOR

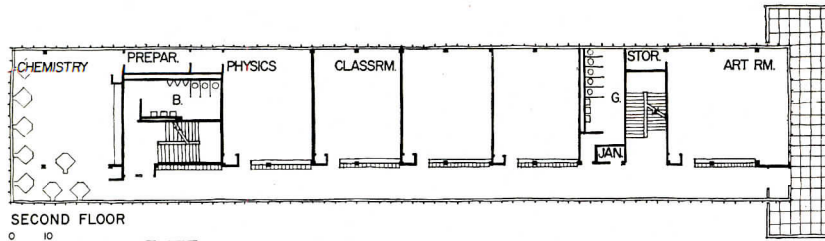

SECOND FLOOR

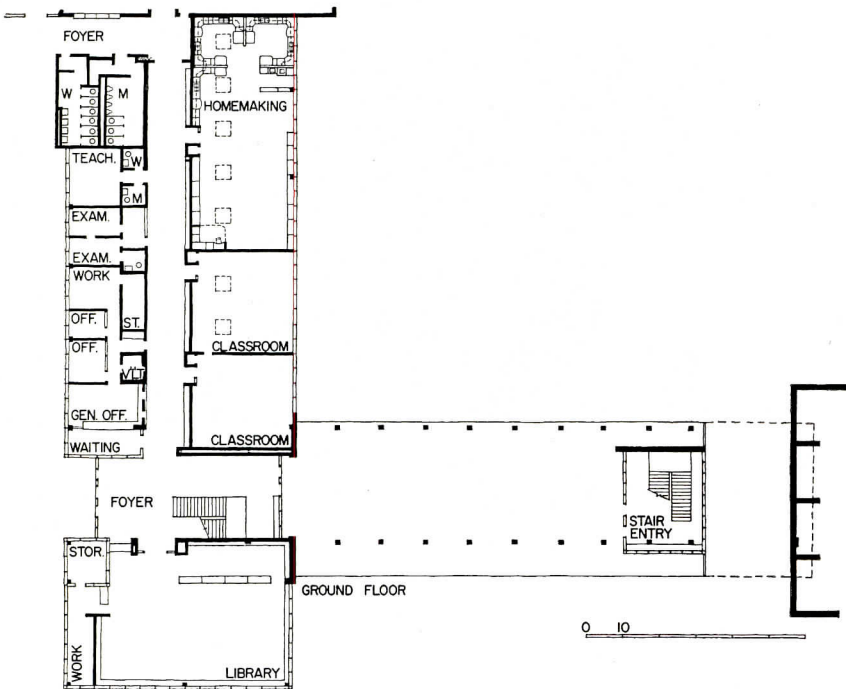

GROUND FLOOR

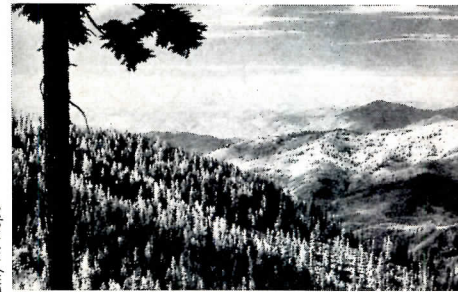

Billy H. Hope

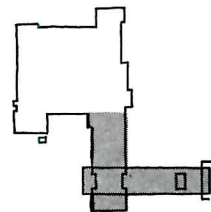

Plans, classroom and administrative wings

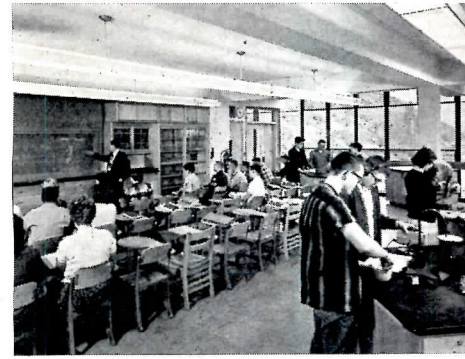
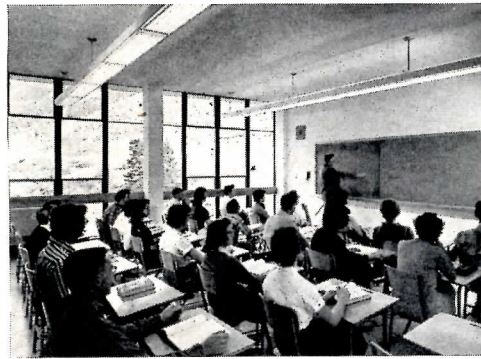
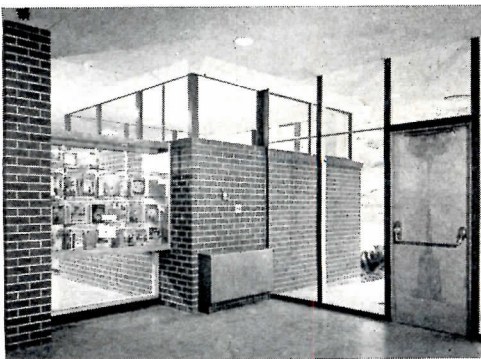

Billy H. Hope

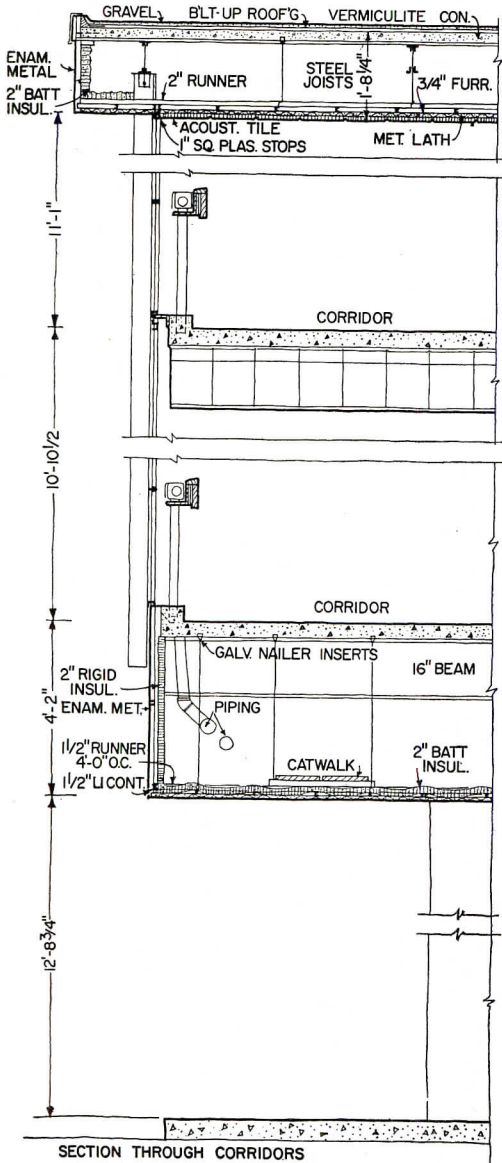
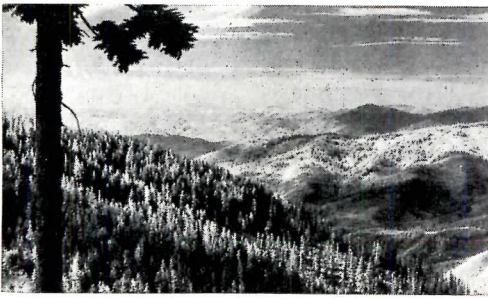

Hedrich-Blessing (except as noted)

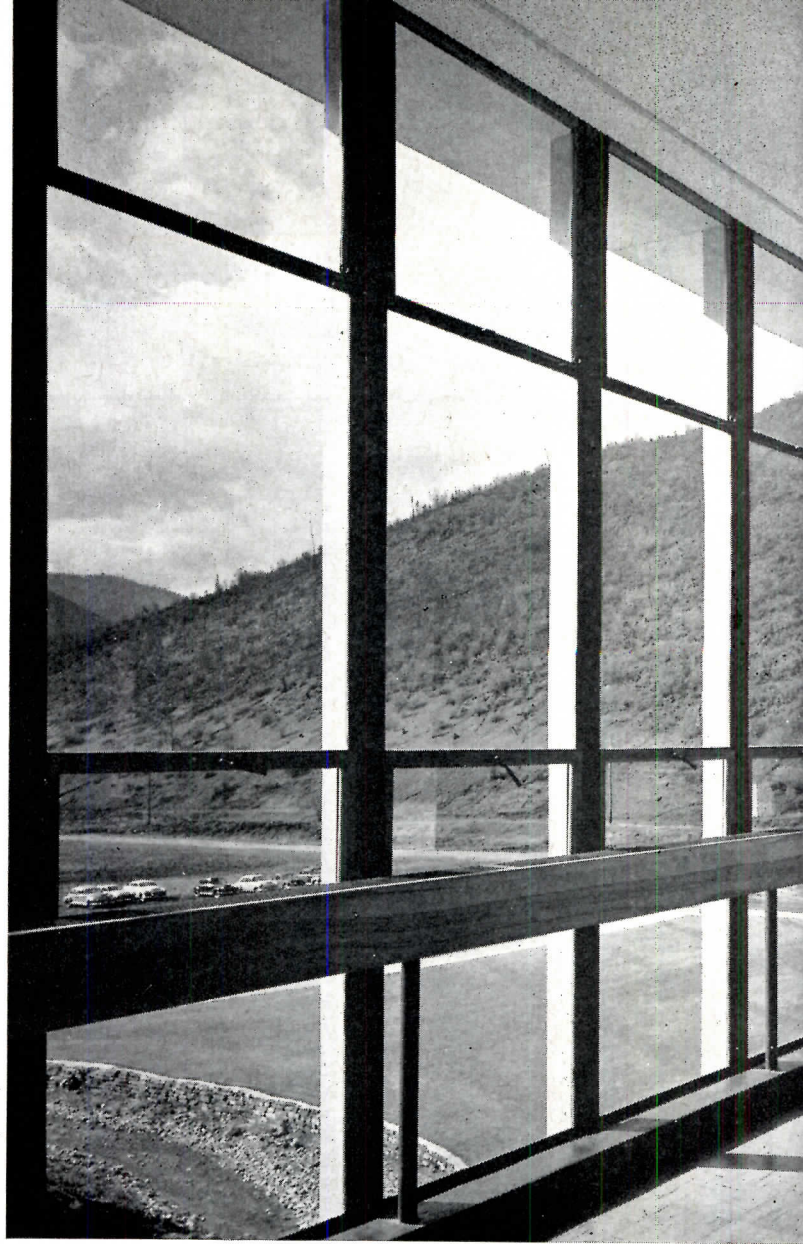

South corridor, details at left

SCHOOL SITES: KELLOGG, IDAHO

self by its own bootstraps. So far, the indications are that this goal has been achieved. The school is in continuous demand by community groups. The students are so proud of their building that they put paper towels under their galoshes to protect the floor. If anything, Andrews is a little worried about their over-careful treatment of the building.

In selecting the best of the five potential sites for Kellogg High School, cost, size, convenience and beauty of surroundings were, as always, important considerations; but protection from spring floods and from storms of wind carrying dust from



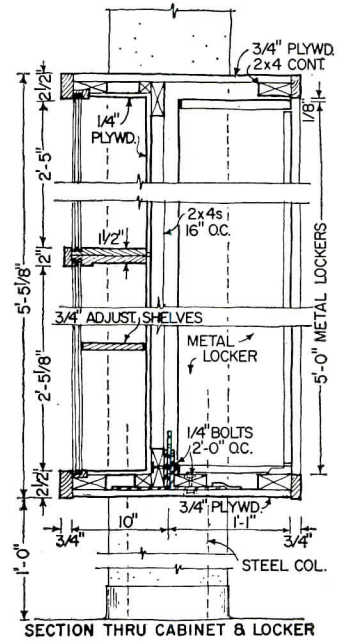
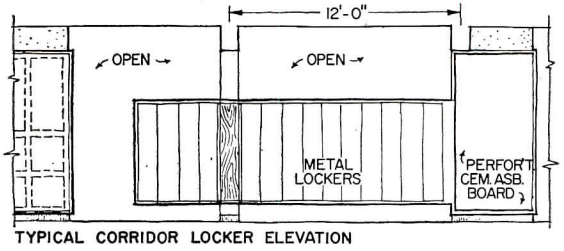
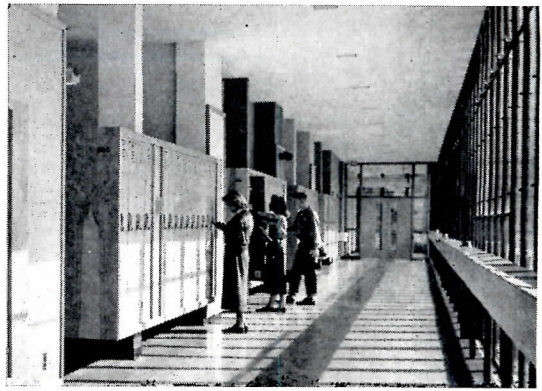

Details, storage cabinets between corridor and classrooms; partition is omitted

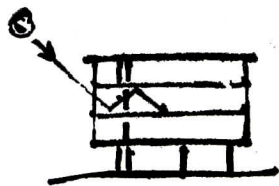

*

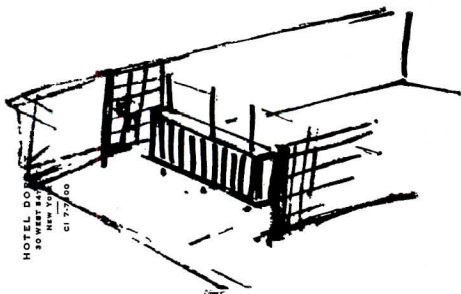
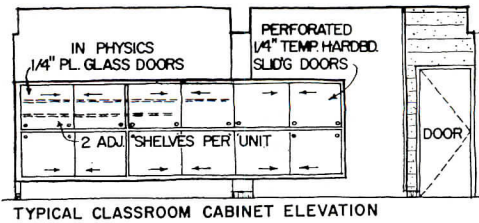
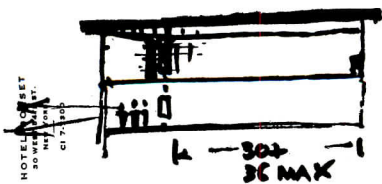

HOTEL DOOR
50 MAX HGT.
100 MAX WGT.
CI 7-1000

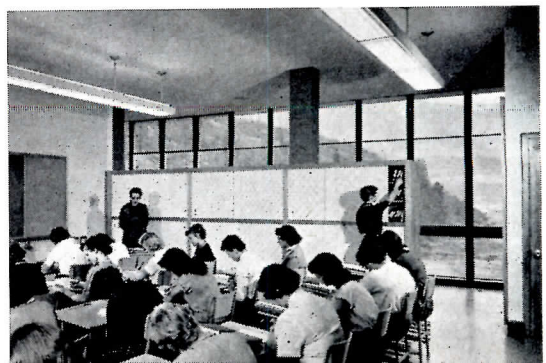

Number of classrooms 14

Grades 10, 11, 12

Number of students:
designed for 600
attendance now 500

Total cost \$927,232

Square feet 68,013

Cost per sq. ft \$13.63

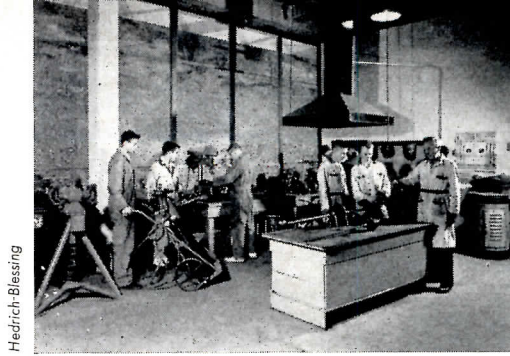

Hedrich-Blessing

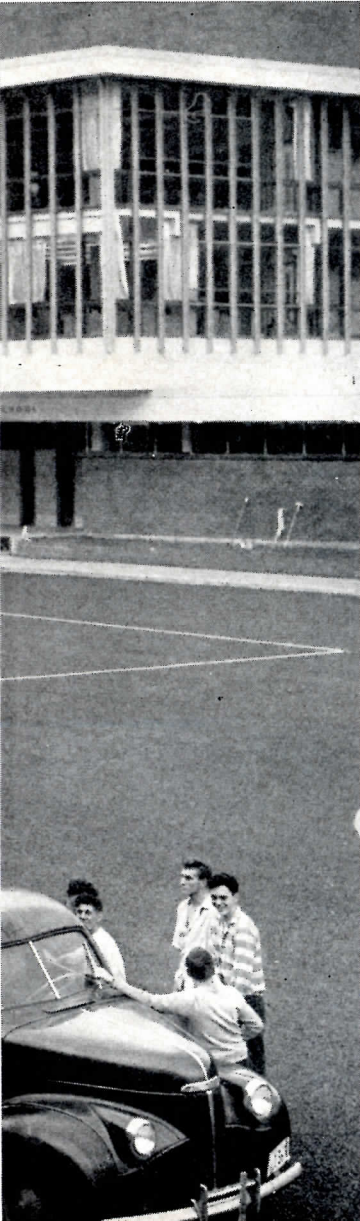
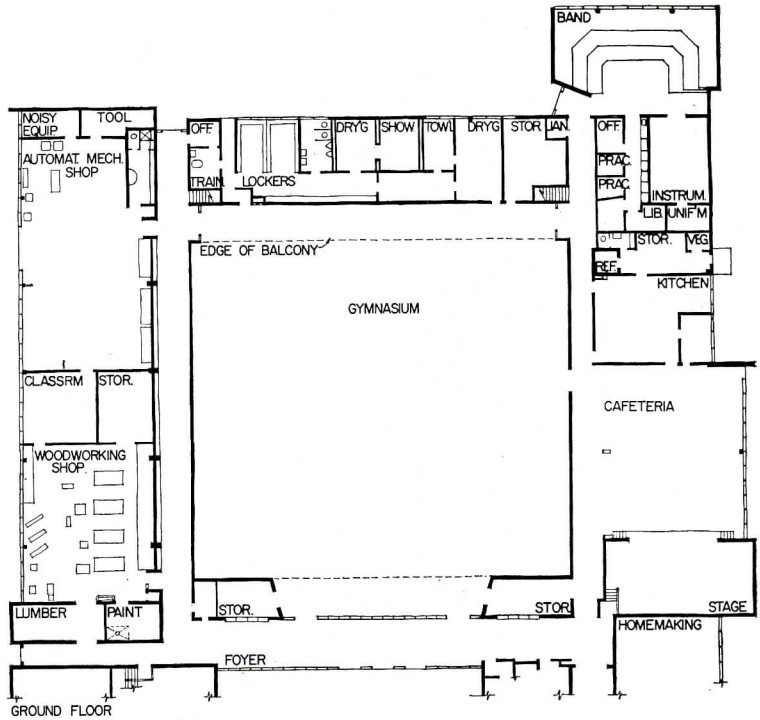
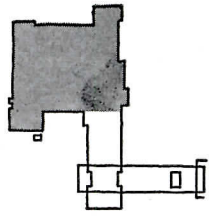
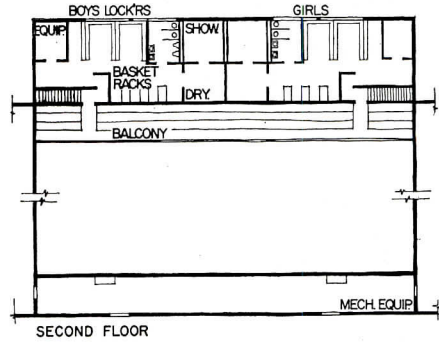

Students' own "Dungaree Day," when students clean building and site thoroughly

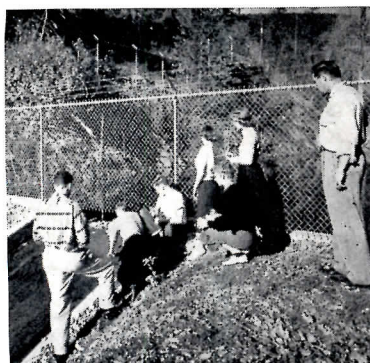

Hedrich-Blessing

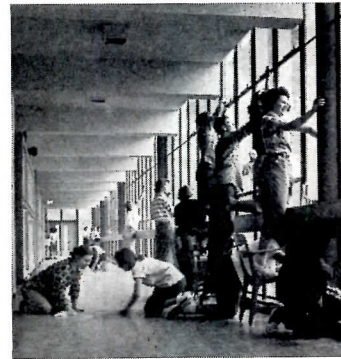

SCHOOL SITES: KELLOGG, IDAHO

the refuse of mining operations, as previously mentioned, was a special local factor. So also was ease of access for bus transportation, since the school is the senior high for the new Joint Class A School District 391, whose area is more than 400 square miles, much of it served only by narrow dirt roads.

We have already described the site finally chosen, Jacob's Gulch; and the photographs give some idea of the natural landscape. The 70 acres bought for the school cost \$50,000. Elevated above the town and the Coeur d'Alene River, the Gulch has few flood problems; the mountains shield it from valley winds and dust; they also help shade the school during warm daylight hours. Placing the building on the site required serious study. In the narrow Gulch there was only a small amount of land level enough — or potentially level — for the essential playfields (which are being developed now and in the future). To string the buildings out along Jackass Creek would have used up most of the available flat area. When the architects developed the concept of bridging the Gulch with the classroom wing and letting the Creek run under it, not only were land-use needs met but there was also a direct recognition of the site's geography. This parallels the intimate relation between the school's curriculum and local needs: this is a technically oriented school community, so technical courses are included; there is demand for machinists, mine carpenters and office workers, so vocational courses have real importance.

Even in construction the school reflects its community. Fill under the ground slab is crushed slag from the smelter; considerable local stone is used; the straightforward structure satisfies a people who live close indeed to their land, including the high percentage of engineers as well as those who literally dig their living out of the mountains. It also stimulates them: the interiors, well visible through the walls of glass set in yellow-painted steel framing, are extremely colorful, and the corridors are a bright kaleidoscope as students pass, easily seen from U. S. Highway 10. And from within the building the mountains, valley, town, and Bunker Hill plant in the distance are constantly in view.

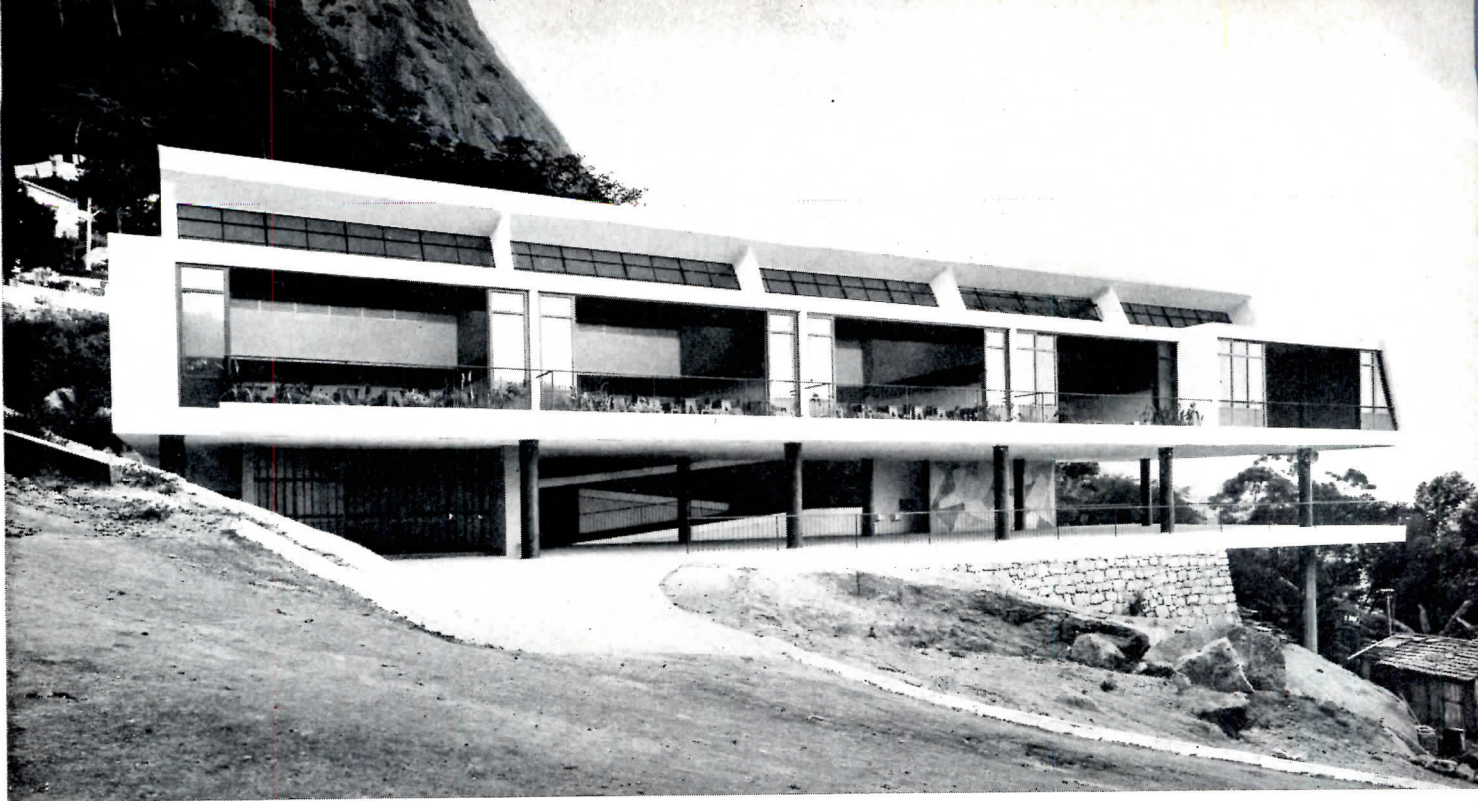

SCHOOL SITES: RIO DE JANEIRO, BRAZIL

Small Elementary School, Tambá Hill, Rio de Janeiro, Brazil. Eneas Silva, Architect. This school is built on the side of the Tambá Hill on the outskirts of the city, in a very difficult situation beside the only road that serves this isolated, hilly region where nearly 4000 people live. It is a picturesque spot, with wonderful views over the sea, the Atlantic islands and the finest beaches of the city. The double fenestration and the southern aspect of the classrooms afford the maximum of cross ventilation and avoid heat and direct sun rays, utilizing only the brightness of the sky vault. The inclined ceilings distribute the light and improve acoustical qualities. The covered patio, for recreation, is also suitable for other school activities.



Jerry

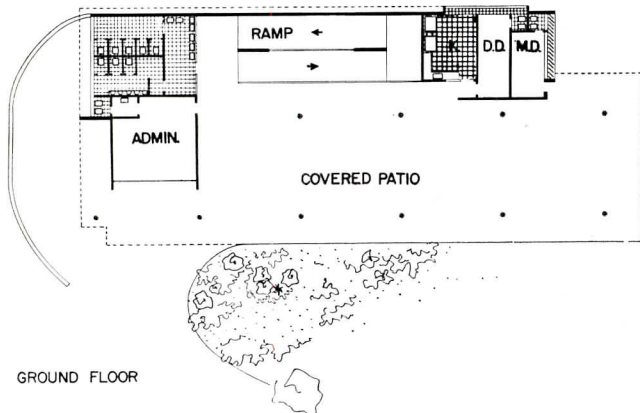

GROUND FLOOR

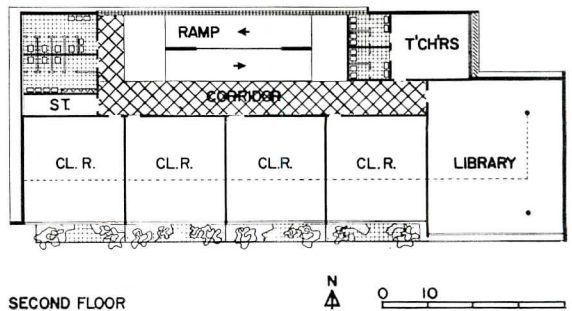

SECOND FLOOR

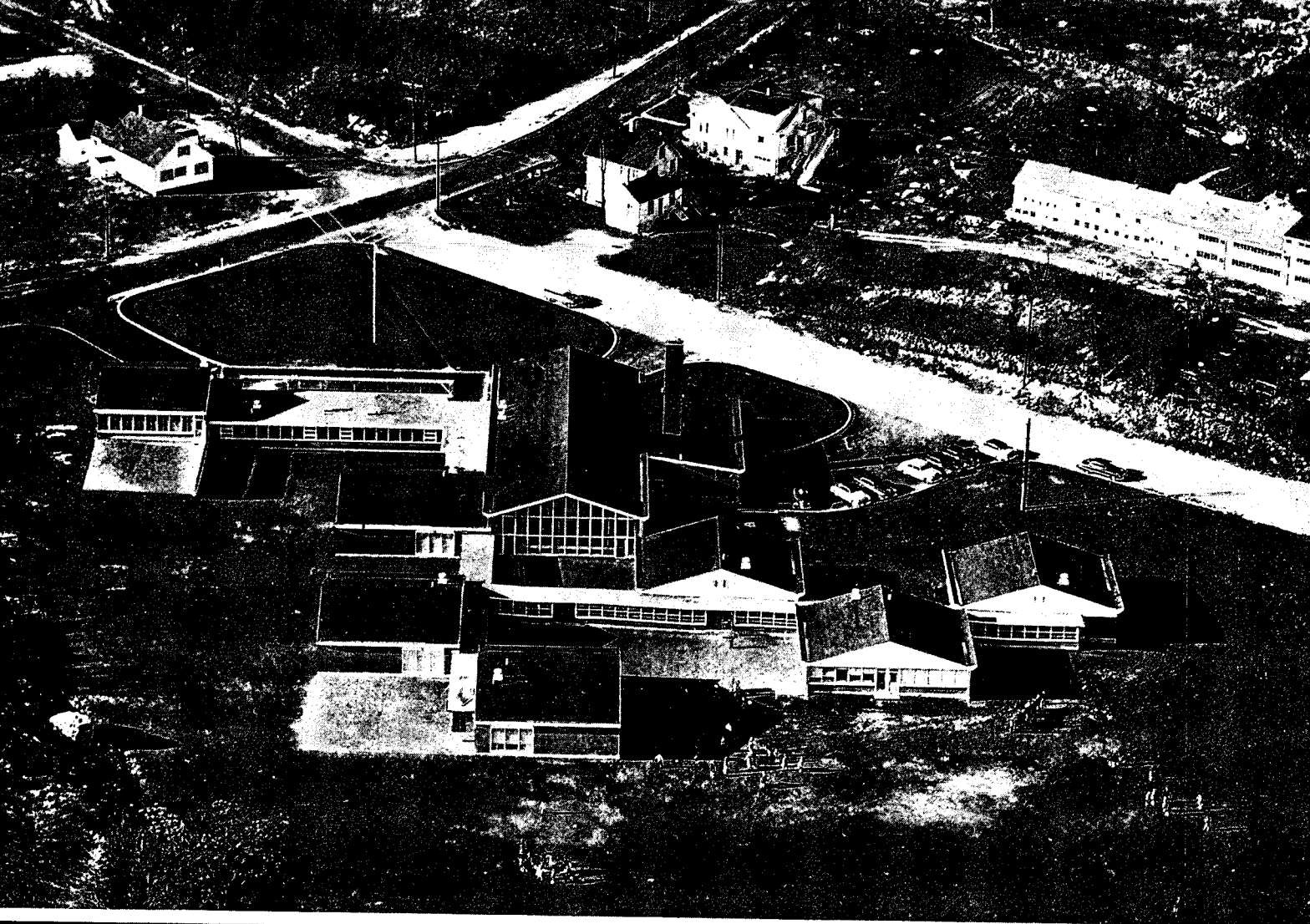

SCHOOL SITES: WESTERLY, RHODE ISLAND

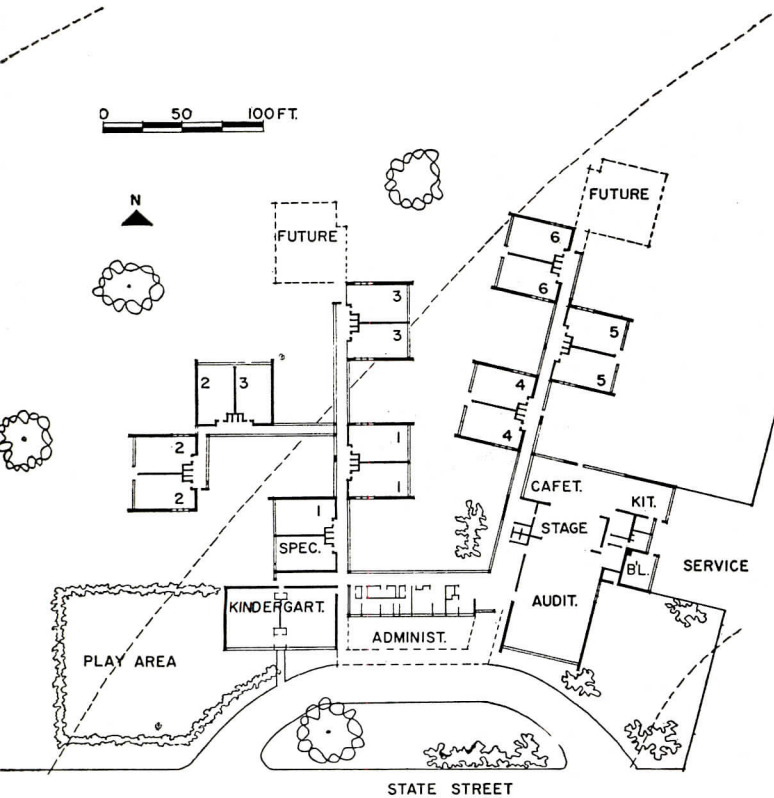

Plan, Westminster Street School

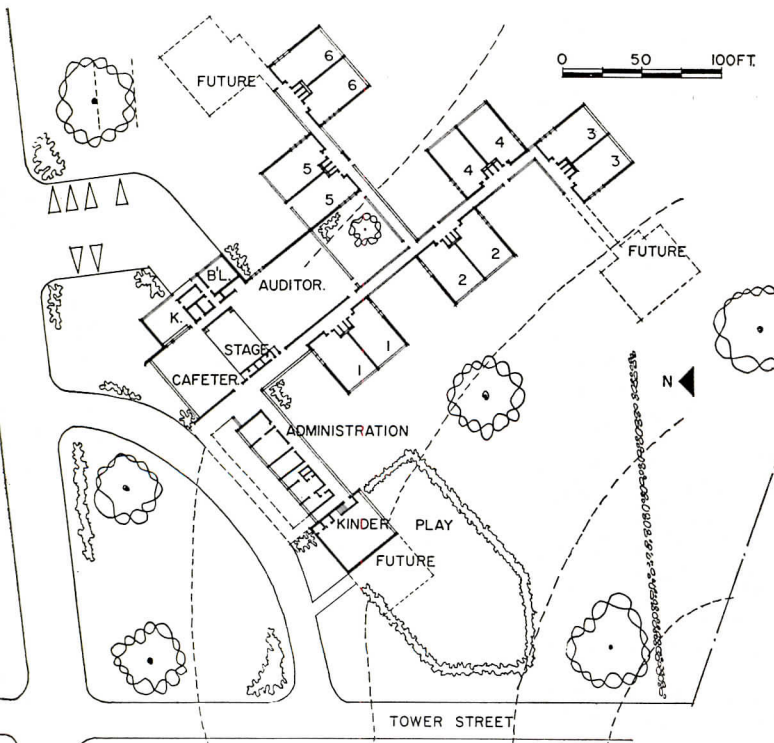

Plan, Tower Street School

Tower Street and Westminster Street Elementary Schools, Westerly, Rhode Island; Harriman, Willis and Hayden, Architects-Engineers; Leo T. Doherty, Educational Consultant. Both these schools were designed as groups of two-classroom cottages. This concept originated at the Tower Street School whose site was somewhat irregular topographically; in addition there were strong indications of characteristic Rhode Island rock formations not far beneath the surface. Breaking the school into small cottages was believed to be the most economical method of construction.

The decision to build in this fashion was under-

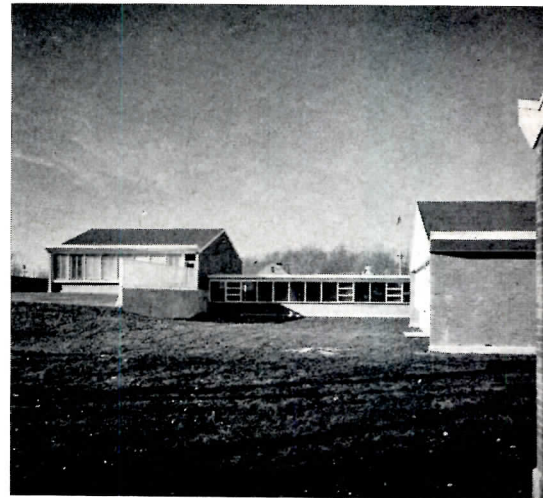

Joseph W. Malliar

taken only after thorough investigation of several different types of layouts. All were one-story, but the Westminster Street School was first developed as a "single-loaded corridor" scheme. In all some thirteen different schemes were considered, some composed of four-room cottages. When the various schemes were presented to the Building Committee the two-room cottage idea was accepted first for the Tower Street School and then, because it offered so many educational advantages, was selected also for the Westminster Street School. Characteristics of the accepted plan which the Committee found particularly valuable were: 1. Neighborly character of the individual cottages; 2. Appropriate scale and a home-like atmosphere suitable for elementary school children; 3. Adaptability to hilly site conditions without excessive excavation and with little or no useless construc-

SCHOOL SITES: WESTERLY, RHODE ISLAND

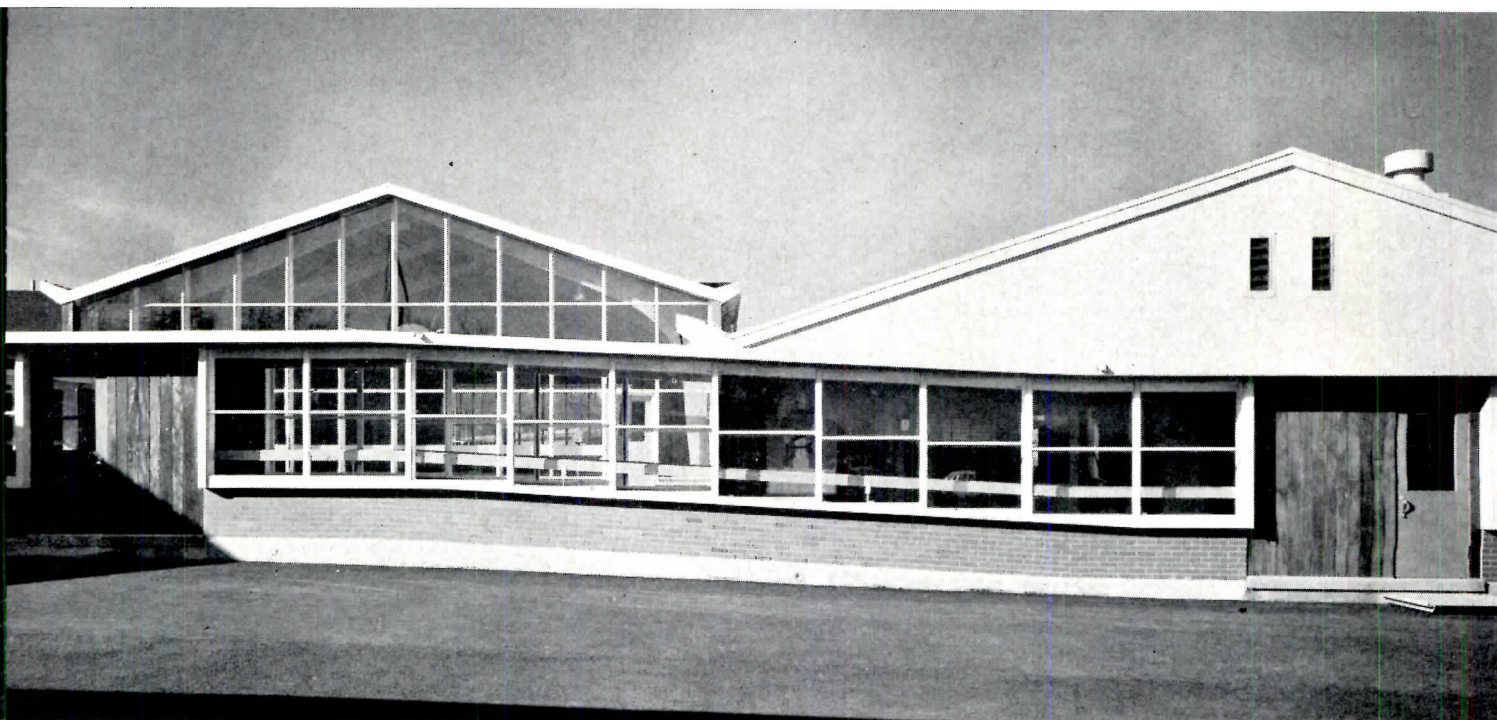

Joseph W. Molitor



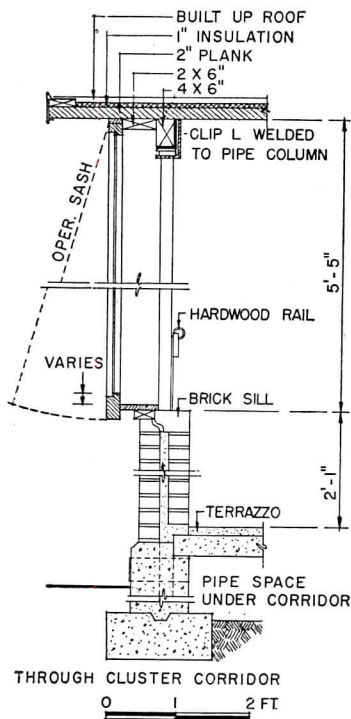

tion; 4. Repetition of small units which if necessary could be built separately by small local house builders bidding in competition against one another, rather than under a single large contract; 5. Simplicity of further extension by adding one or more cottages identical to the existing units (mechanical facilities are large enough to handle further additions); 6. Because the buildings are fairly close together, the maximum of the small sites can be used for play fields; and in addition there are sheltered courts between the units suitable for play, for teaching areas and for assemblies.

The buildings in both schools are joined by covered ramped walkways of simple wood framing supported by steel lally columns resting on cavity brick walls which extend only to window-sill height. A continuous pipe space under the corridors provides for distribution of mechanical and electrical services; the ramped corridors themselves are heated by waste heat from the mains beneath the floor. The glazed portions of the walls are formed of simple wood sash very similar to ordinary domestic storm sash.

Several factors influencing the decision to use two-room rather than four-room cottages had their basis in severely practical considerations. Space required for internal circulation in the four-room unit was much greater. The number of pupils to be accommodated in the four-room unit toilets required fixtures and floor area determined on a different basis than for the smaller unit. Similar savings were also realized in relation to the total

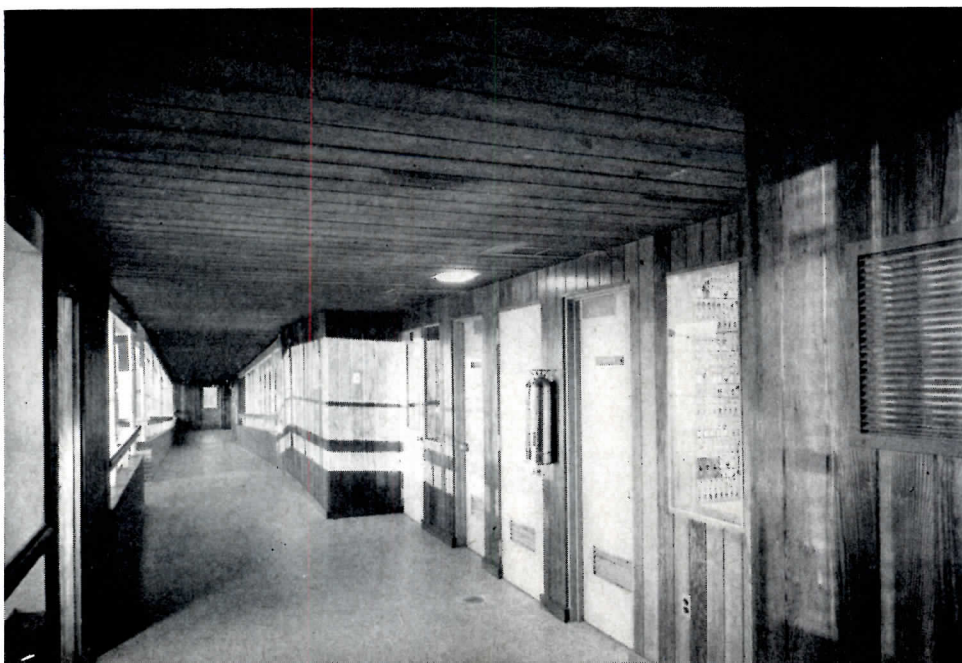

SCHOOL SITES: WESTERLY, RHODE ISLAND

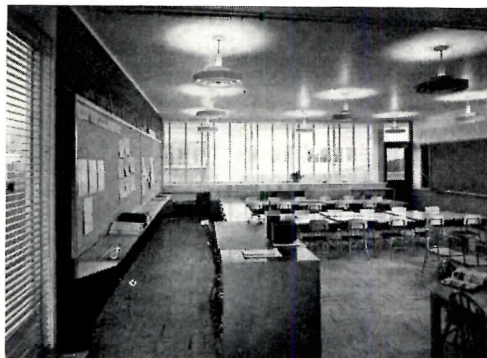

Typical Classrooms

Joseph W. Molitor

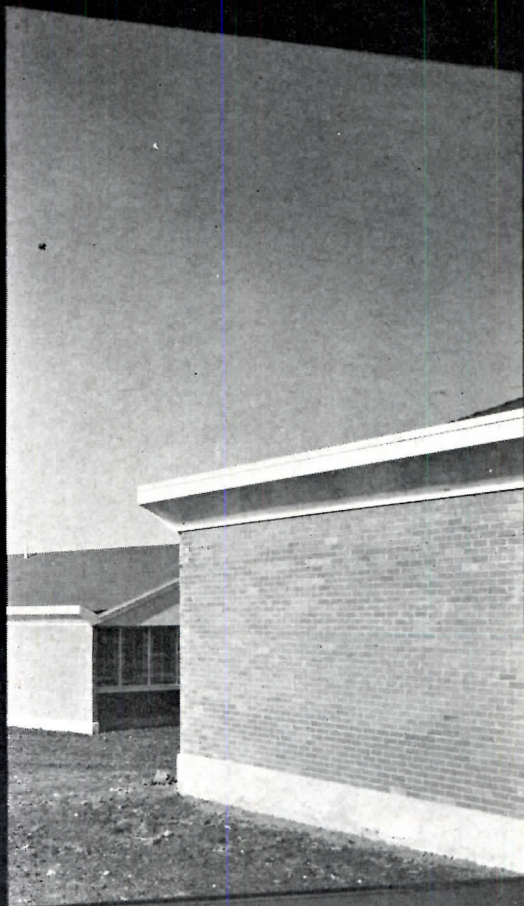
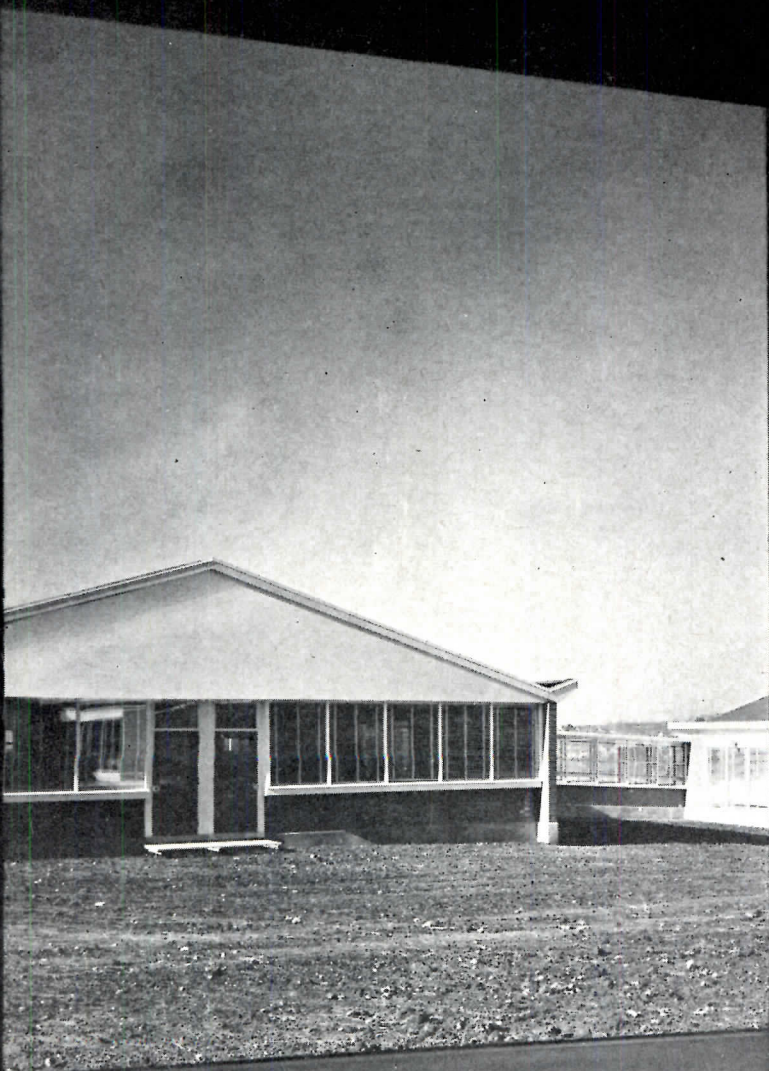

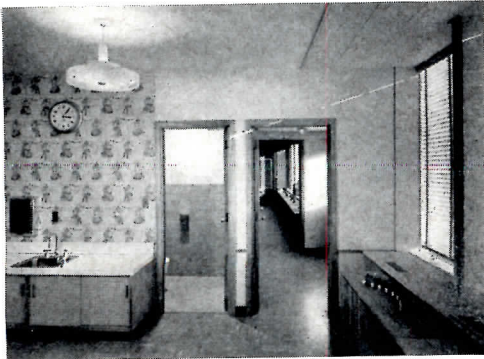

Entrance to Classroom Toilets



Kindergarten

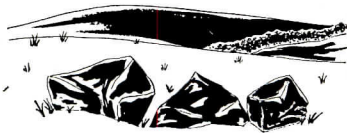

circulation area of the school and the amount of circulation per classroom. Only one item was increased, the number of linear feet of corridor. However the cost of the corridors was very low. Educationally the two-classroom units were considered to be more flexible in use while the four-classroom units were demonstrably more difficult to adapt to site conditions. The two-classroom units provided rooms which could be lighted from three sides. Rooms in the four-classroom units could have light from only two sides. Furthermore, no reasonable four-room unit overall scheme seemed possible to develop without having the classrooms in adjacent units face one another across the small courts. Similar conclusions were reached in comparing the single-loaded corridor scheme first developed for Westminster Street School with the two-room unit scheme. All the classrooms have movable wardrobes, teachers' cabinets and other cabinet work. One end of each classroom is separated from the rest of the room by floor to ceiling drapes. Each room has a work counter with two small sinks, an art shelf, display panel and display cabinets.

The cafeteria and auditorium can be combined. The stage is between the two and can be opened to either or both of the rooms. The auditorium

SCHOOL SITES: WESTERLY, RHODE ISLAND



Auditorium-Playroom looking through stage to Cafeteria beyond

Joseph W. Molitor

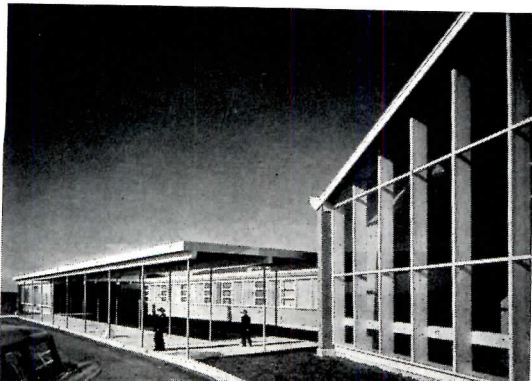

serves also as a playroom for the elementary school children, who do not need a full gymnasium. In the Westminster Street School a low-ceilinged library area was designed in conjunction with the cafeteria and can be used for overflow eating space. Corridor in this area can be used in conjunction with the library except at mealtimes.

Structurally, both schools are extremely simple. The cafeteria-auditorium structures have laminated wood arches which stand free of the exterior walls in order to increase the feeling of lightness. The arches are used to distribute the electrical conduit which is run up their backs and tops to feed lighting fixtures mounted on their soffits. Each of the classroom buildings is built of brick and wood framing, with large amounts of glass in the side walls and a concrete floor slab. All heated areas have double-sealed glazing of modular dimensions selected to simplify manufacture and installation. In general masonry walls are exposed on both sides; the wood framing is very much like typical residential construction.

Ironically, it should be noted, although the two-room units were chosen primarily to avoid site difficulties, when construction was started on both schools it was discovered that the indications of rock were misleading. What apparently were substantial outcrops were merely boulders deposited on the site in prehistoric ages. However, the schools have proved so satisfactory educationally that the local school officials are entirely satisfied with them.

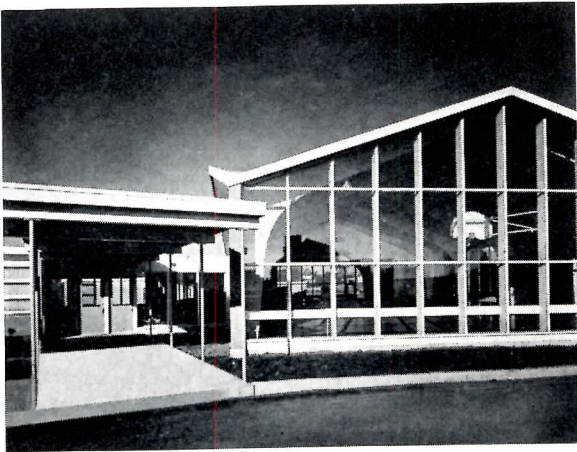

Cafeteria looking towards stage from Library area

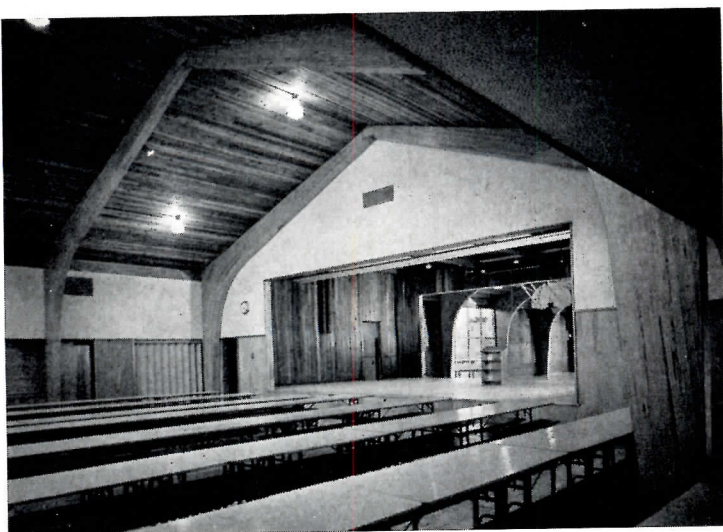

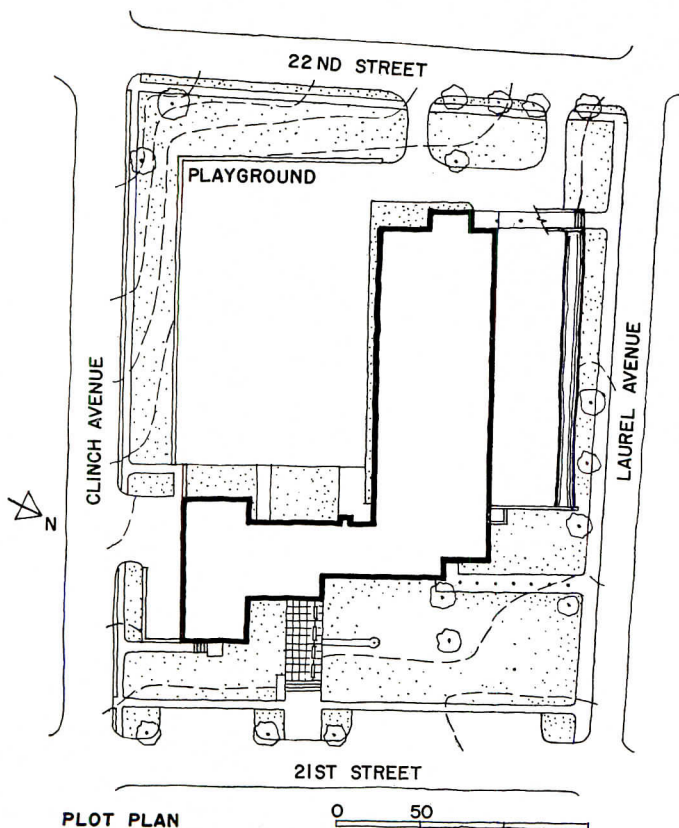
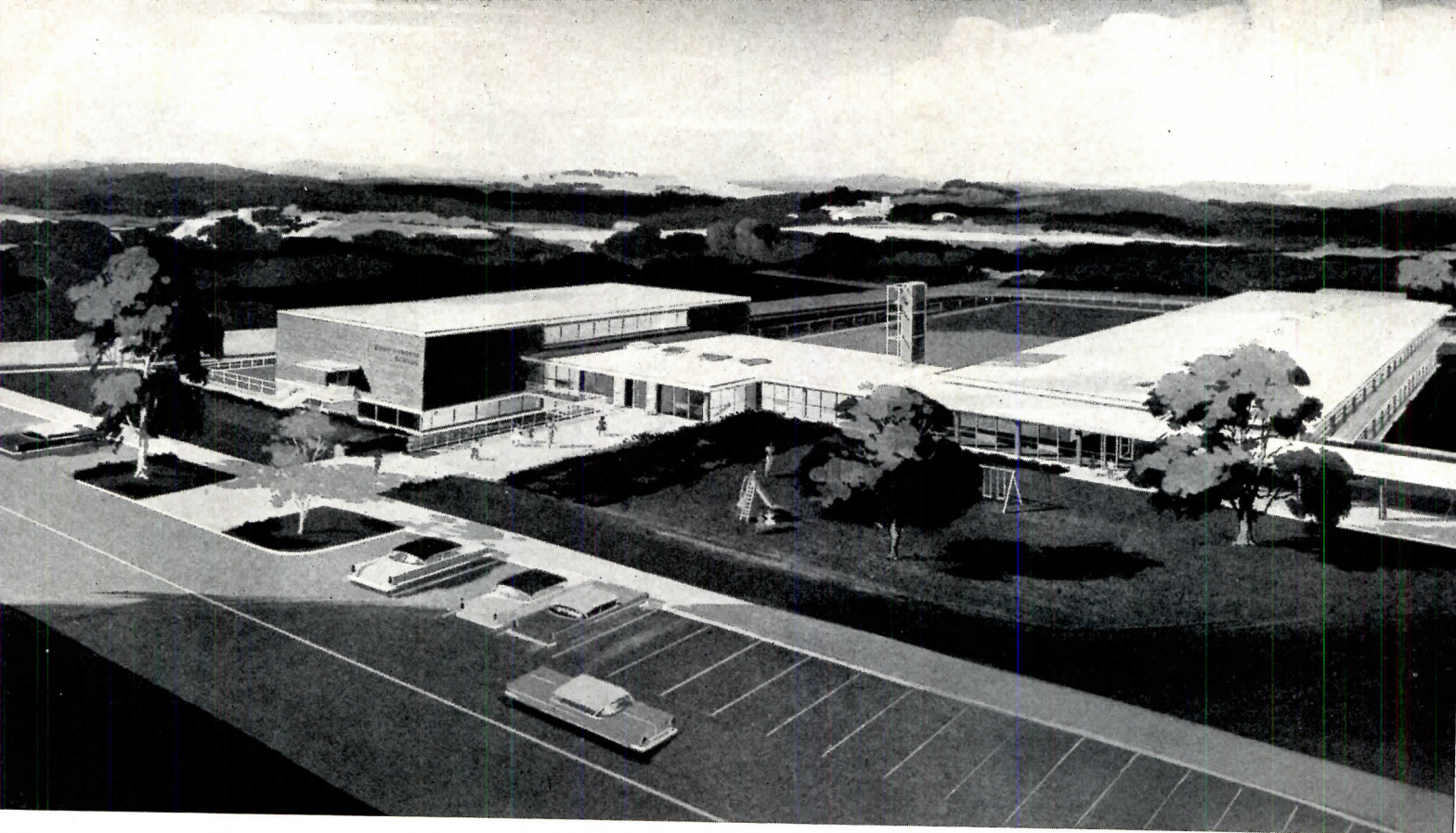

Fort Sanders Elementary School, Knoxville, Tenn. Painter, Weeks & McCarty, Architects. Two problems were encountered in designing this urban school: a small site consisting of a city block with a diagonal drop of 30 ft; and the necessity of accommodating both handicapped and normal children. The solution to one resolved the other. The five classrooms for cerebral palsied, multiple-handicapped and trainable mentally retarded children were placed on the lower level. Here they have the required nearby station-wagon unloading dock, private play area and level access to the cafeteria. For normal children there are eight self-contained primary classrooms, one large classroom (for special instruction or future library), offices, playroom, cafeteria and kitchen and special dining room. Now under construction, Fort Sanders School will contain 50,028 sq ft; contract price is \$606,459,000 of which about \$25,000 is for site improvements. Cost per sq ft is under \$12.

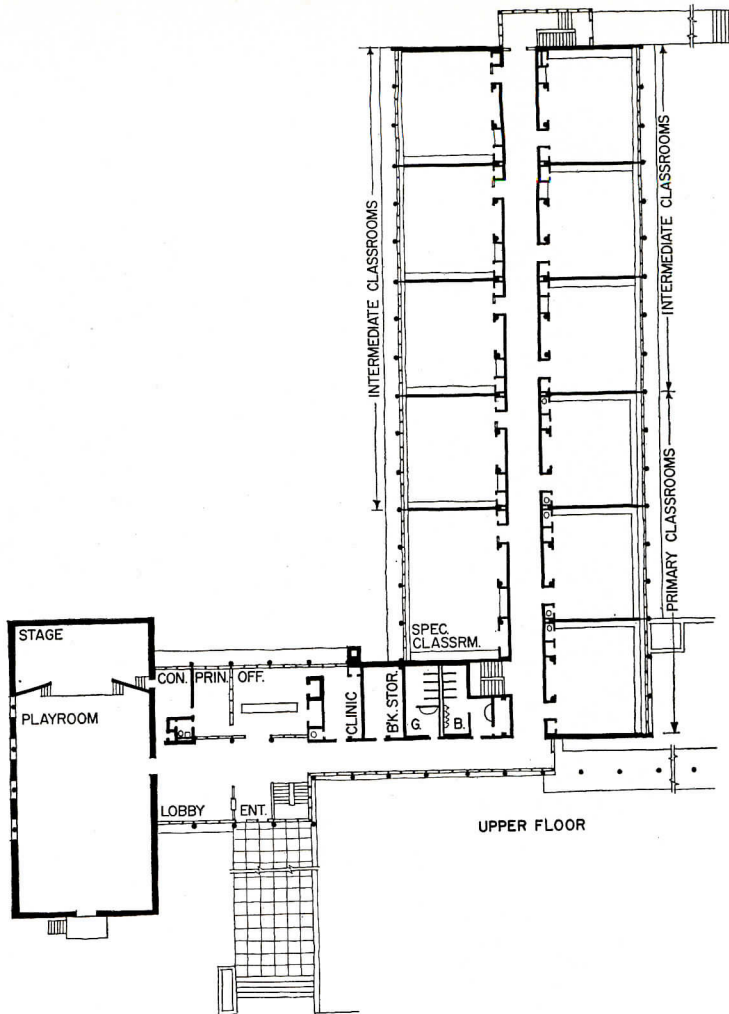
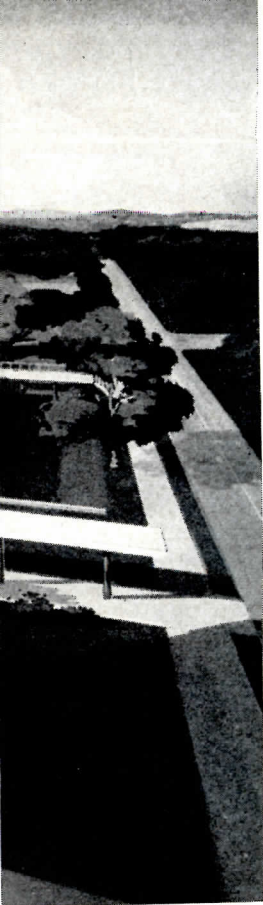

SCHOOL SITES: KNOXVILLE, TENNESSEE

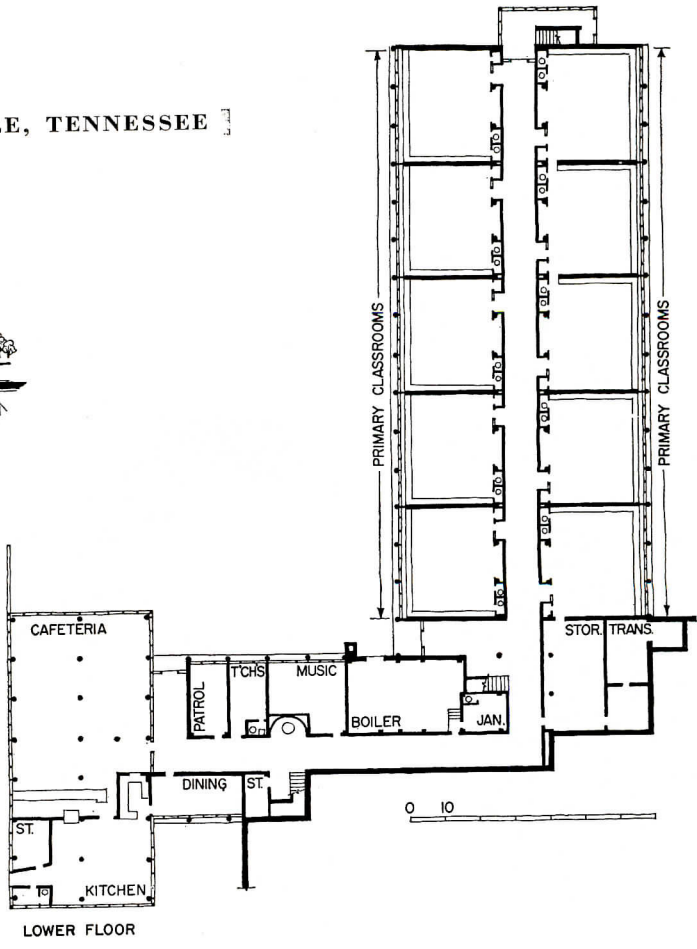
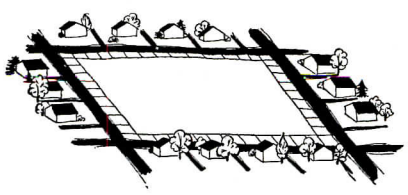

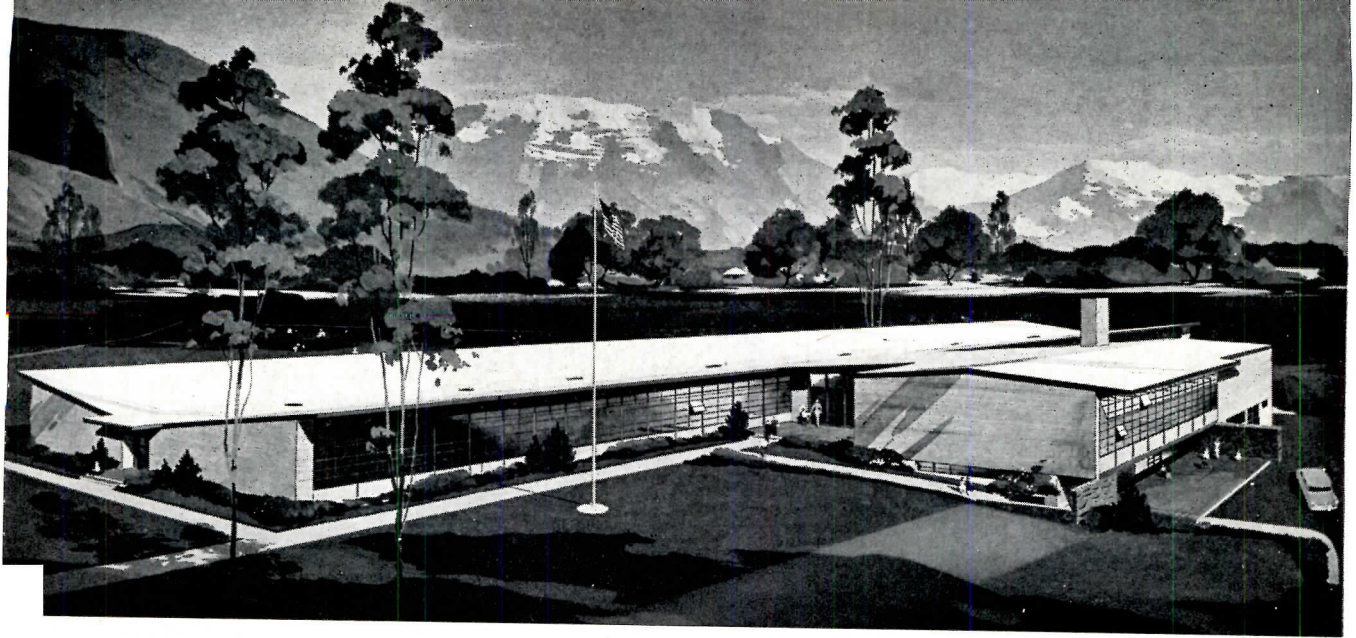

SCHOOL SITES: UTAH

Proposed Elementary School, Pleasant Grove, Utah. W. Rowe Smith, Architect.

Not yet under construction, this school was designed for a sharply sloping site. At the lower grade is a two-story unit containing, on its lower floor, cafeteria, kitchen and boiler room; on its upper floor, an auditorium and stage. Stairs and a ramp connect both floors to the central lobby at an intermediate elevation, level with the double-loaded-corridor classroom wing. Toileting arrangements shown in the plan indicate the grouping of grades, from kindergarten through intermediate. Note the enlarged corridors adjacent to the kindergartens, somewhat private yet integrated with the rest of the school, and useful for dressing children in outdoor winter clothing as well as for play space in bad weather.

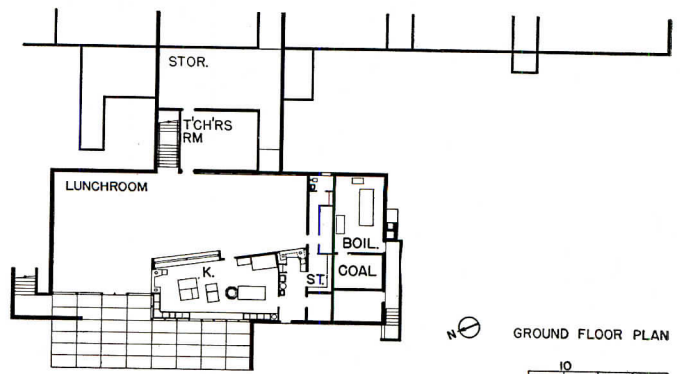
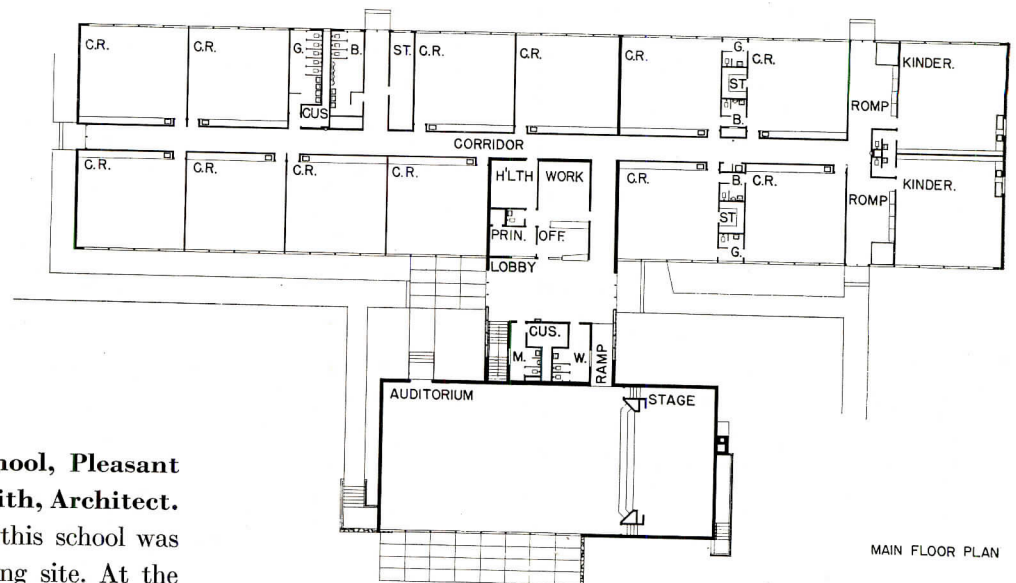

MORE ABOUT MAXIMLITE SCHOOLS

The February 1956 issue of ARCHITECTURAL RECORD contained an article on the subject of prefabrication and proprietary plans for school buildings. Among the proprietary schemes offered to the American market and discussed in that article was the Maximlite school. Maximlite's originator, T. Ewing Shelton, Architect of Fayetteville, Arkansas (who holds certain Maximlite design copyrights) has objected to last February's article. Mr. Shelton has had the Interstate Industrial Reporting Service Incorporated of 675 Fifth Avenue, New York 22, New York, prepare the following article. In fairness to all concerned, we publish it herewith verbatim, exactly as it was submitted.

Frank G. Lopez

MAXIMLITE school design utilized 70% of glass blocks in the exterior walls of all our schools," asserted Mr. T. Ewing Shelton, Architect (Copyright Holder — 1952 — of the Maximlite School Design) Fayetteville, Arkansas, "to 30% of masonry. We began this feature of our schools in 1951, and in the short period since then, have already used 58 carloads of glass blocks in construction . . . both in the United States and Canada.

The Use of Glass Blocks

"At the outset glass blocks are more expensive than ordinary flat pane glass but their ultimate advantages of design, durability and construction use outweigh by 75% the original cost. Yet the Maximlite school, considering the cost of the glass blocks, is 20% to 40% less expensive to build than the conventional type of school! Even with the glass blocks we can build a school at \$5.00 to \$9.00 a square foot . . . whereas the ordinary type of school will cost from \$15.00 to \$20.00 per square foot.

"The use of glass blocks, in a sense of the word, is one of the basic features which gives the Maximlite schools their distinctive and appealing characteristics such as increased visibility and light in the classrooms coming from two outside walls instead of the half-blind lighting in conventional classroom design.

Glass Block Lighting

"We have no 'dark-corners' in any of our Maximlite classrooms because of the extensive use of glass blocks. Tests have been conducted on this salient characteristic of the schools. One ex-

periment, for example, to determine the light intensity on desk tops showed that with an average of 6,500-ft-c on the exterior . . . tantamount to a bright sun the light varied from 205 to 665-ft-c or less than 4 to 1. In comparison, tests were made on an overcast day with approximately 1,000-ft-c on the exterior and the intensity varied only from 38 to 115 which is still less than 4 to 1!

"Three points we constantly strive for are optimum light, good ventilation and acoustical uniformity. Glass blocks are the medium which help us attain all three objectives. Where acoustics are concerned, the glass block walls permit a uniformity of sound without 'bouncing' effects on the ears of the children . . . and the teacher can be heard easily throughout the approximate 800 square feet of our rooms.

"The glass block courses in the walls are supplemented by movable pane glass vision strips which open, for example in the Root Elementary School a full 100% . . . permitting a cross ventilation at any time during the day. Bolstering this advantage are the results of a scientific experiment made on glass blocks by the University of Texas. Among the findings . . . it was found that, in comparison of glass blocks to flat pane glass, the afternoon dry bulb temperatures in the flat glass room averaged 2.2° F higher than those in the glass block room.

Design and Construction with Glass Blocks

"Up to the present time we have used only two types of glass blocks in our school design — the 12" x 12" and 8" x

8". In the near future, however, we hope to enhance our design through the use of a 6" x 2" or a 6" x 6" block. The possibilities of glass block design are infinite, although we feel the first use of glass by many was unwise from the standpoint of architectural design in that they seemed to be used indiscriminately in many buildings without taking into consideration the overall design and purpose of the building. Naturally, we strive to avoid any such eye-discomfort in our use of blocks.

"In fact it is the glass blocks themselves which give us the symmetry of line in our schools. Two typical examples are the Root Elementary School here in Fayetteville in which we used 4,200 glass blocks and yet the building cost only \$121,000, or the St. Joseph Parochial School in which a proportionate number were used and this school cost but \$76,319.

"Glass blocks readily lend themselves to more solid building construction than any form of pane glass because of their compressive weight resistances and are ideal for our type of walls which we support by means of 5" 'H' steel columns. Construction-wise they also permit light to be constantly over the left shoulder of the children irrespective of the position of the students in the classroom.

"The lighting itself is of vital concern from a health standpoint of both teachers and pupils. On April 11, 1956, a daylighting survey was taken at the Root Elementary School in which Munsell Color Judgment Scales were used. In each of the three test classrooms the glass blocks were of the OI 480 design, with blue-green fiber glass screen above

eye level and Vue blocks around the vision strip area. The results can be summed:

“ . . . it can be seen that by comparison the Maximlite design offers considerably more daylight throughout the room as well as improving the distribution of this light between the inside wall and outside wall of the classroom.”

“In this test, classroom CR-9 had reflectances, for example, of 75–80% on the ceiling, 73% on the upper wall, on the wainscoting 60%, and on the floor 25%!

Characteristics of the Maximlite School

“What characterizes the Maximlite school,” continued Mr. Shelton, “more than anything else is the 100% attention we give to the classroom in design; the utilization we make of the outside walls for classrooms and study areas; our use of light directional prism type glass block in a consistent ratio of 7:3 in the exterior walls; the total elimination of furnace rooms in the schools; the maximum number of outside exits per classroom; our construction lends itself to group education without the necessity of long connecting corridors so familiar in ordinary campus type school buildings; 100% acoustical control due to the shape of the walls; perfect cross ventilation because the standard 45' wall gives better ventilation due to the 120° angle of the wall and the extra footage of the window area; our standard perimeter heating plus 100% control of the heat in individual classrooms; perfect classroom lighting at all times through a total elimination of dark corners and our illumination per room can run 194 in foot candles and brightness in foot lamberts 530!

Basis of Maximlite Construction

“What we have done,” explained Mr. Shelton, “is simply to utilize the unlimited properties inherent in the 360° angle. On this basis the several classrooms of any one school are arranged in groups of two, three or four, although a single room can be used.

“The hexagon (actually 5-sided) is the basic unit and the outer walls coincide with the outer sides of a regular hexagon (6-sided). Each room has two outer wall portions of substantially equal length at an angle of 120° to each other. The adjacent outer wall portions of adjoining rooms are aligned and the same length . . . so that together they form one outside wall of the school building. A partition wall extends in-

wardly from the midpoint of each of the outside walls. Thus, as the outer wall portions are at an angle of 120° the partition walls converge inwardly from the outside walls of the building. Side walls extend inwardly from and substantially normal to the end extremities of the outer wall portions.

“Because of this design, the classrooms have many advantages over the conventional rectangular or square rooms. First, each room has the advantages of a corner room in a conventional building as it has outside walls at an angle to each other. Light and air may enter through both outside walls and thus permit cross ventilation.

“Due to the 120° angle of the outer wall to each other, the light from each outer wall portion of the room supplements the light from each of the outer walls and is concentrated at the innermost part of the room. This effect may be compared to the action of a funnel as it concentrates the light from a wide area along the outer wall portions into a narrow area at the inner part of each room.

“We have entirely eliminated an otherwise major concern on the part of parents, students and teachers by this design. Because of the short corridors in each cluster of classrooms the occupants may be evacuated with a minimum of confusion and time. For example, 760 children and teachers were evacuated from the 24-classroom school at Hayesville, Kansas, in 52 seconds during fire drill.

“The light directing glass blocks are used in each outer wall portion above clear fenestration. The glass blocks are designed to direct the light striking the outer surfaces slightly upward and inward to form vertical planes at right angles to the outer wall portions. A large amount of light passing through the glass blocks is also diffused.

“Lighting in all portions of the room is thus uniform and 100% superior to light in a conventional room. Even in a conventional corner room the light rays, directed inwardly from each outer wall are at right angles to each other and, therefore, do not supplement each other.

“Due to the shape of the room with minimum parallel wall surfaces, acoustics are improved 100%; secondly, the shape of the room lends itself ideally to perimeter heating.

Cost of the Maximlite School

“We will design a Maximlite school,” added Mr. Shelton, “which will be from 20% to 40% cheaper to the taxpayer or institution building the school. We do

not say this to brag but, on the basis of figures from awarded contracts to bonded contractors, the Maximlite school runs from \$5.46 a square foot to \$8.00 a square foot, in contrast to the average cost of a schoolhouse in the United States which is \$15.00 a square foot and up!

“One of the reasons we can so design is because we utilize the 30 . . . 60 . . . and 90° angles in all our specifications (these are standard cuts). Consequently, at the completion of one of our buildings the residual material can be carted off in a wheelbarrow! Not a scrap of bulding material is wasted.

Specific Schools

“As a further example, and citing specific schools to prove the point, we can discuss, say, the Christian Brothers High School and Residence at St. Louis Park, Minnesota. The school itself was 68,143 square feet, the residence an additional 15,582 square feet . . . a total of 83,413. We built for \$8.53 a square foot for the school . . . the residence and the school combined at \$8.87 a square foot.

“Our contract for the Maximlite High School in Ormsby County, Carson City, Nevada, for instance, came to \$373,202.00 for an area of 39,640 square feet or \$9.39 a square foot.

“Another indication of our ability to save the taxpayer on school construction costs and give him the best . . . namely glass blocks . . . is the Maximlite High School at House Springs, Missouri. In this school we had 45,200 square feet including the Industrial Arts Shop. The contract was awarded for \$331,984.75 or \$7.34 a square foot.

“The important point to this school, however, is not only the low cost but what the students and school board received. The school has 15 classrooms, Home Economics Room, Science Laboratory, Study Hall-Library, Book Repair Area, Central Toilet Rooms, General Office, Private Office, Conference Area, Supply Storage Vault, Clinic, Teachers' Room for Men and Teachers' Room for Women, Dark Storage and Light Storage Rooms for Science Laboratory, 3 Janitor's Cleaning Rooms, Concession Area, Gymnasium (seats 1,000 in bleachers), a 20' x 60' Stage with 2 Dressing Rooms, Girls' Locker and Shower Room, Boys' Locker and Shower Room, Music Practice Room, Music Office, Instrument and Uniform Storage (located below Stage Area) Industrial Art Shop (33' x 70') located separately from the school.

(Continued on page 320)

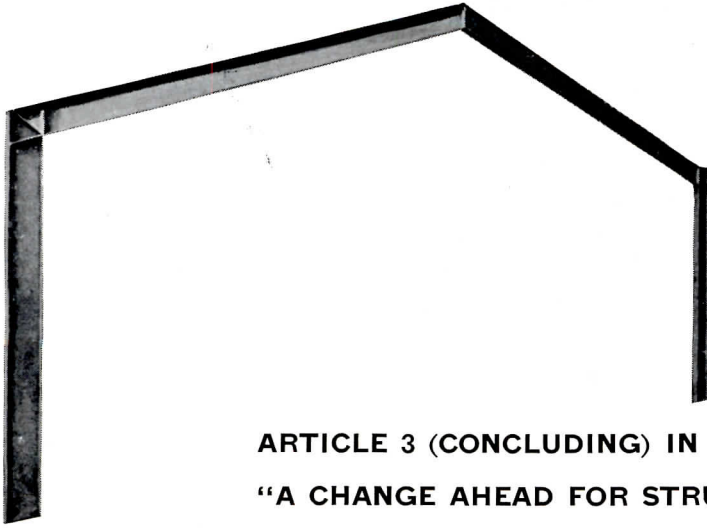

ARTICLE 3 (CONCLUDING) IN A SERIES,
 "A CHANGE AHEAD FOR STRUCTURAL DESIGN"

PLASTIC—LIMIT DESIGN OF STEEL FRAMES

By Edward Cohen, Associate, Amman & Whitney, Consulting Engineers, New York City

ARCHITECTS AND ENGINEERS throughout this country and abroad are looking toward plastic-limit design of steel structures as a means of obtaining greater elegance and economy in steel construction. Engineers are concerned also with the accurate computation by limit methods of the ultimate load capacity of structures, something which is not possible in conventional design.

In plastic design allowable stresses and elastic stress distributions are disregarded and members are designed at critical sections for their full strength after yielding.

Limit design is the proportioning of structural members such that the entire structure, acting as a unit, is capable of supporting the working load multiplied by a given factor of safety, failure to occur when this load is exceeded. Limit design can be applied to all types of structures — beams, trusses, frames, suspension systems, etc. It gives results different from those found from conventional methods when the structure is statically redundant or indeterminate, as for example, rigid frames, continuous beams, lattice trusses, etc.

Although limit analysis or design does not necessarily require yielding or plastic hinges, present thinking along this line with respect to buildings is concerned primarily with *limit* design of all-welded steel frames making full use of the *plastic* strength of the steel sections and redistribution of moments after the development of plastic hinges. This special case can be called *plastic-limit* design.

Although limit design is a concept that was unconsciously used prior to the

development of elastic analysis and design methods, the first rational approach to the subject of *plastic-limit* design was made by Kazinczy in 1914 and followed by Maier-Leibnitz in 1917. In 1936 Professor J. F. Baker of Cambridge University became concerned with the problem and has devoted his efforts almost continuously to its solution. It is he and his associates who are responsible in large measure for the development of a practical *plastic-limit* design method. Important contributions have been made in this country by the research teams at Brown University and Lehigh University.

Intensive research has been conducted in this field for the past 15 years, much of it with the support of the welding industry. Although there is still a great need for additional research on various phases of the subject, sufficient information is available at the present time to allow the practical application of *plastic-limit* design methods. During World War II the design of shelters and later the design of structures to resist atomic explosions were predicated largely on *plastic-limit* methods. Today it is recognized generally that the true resistance of structures to blast and impact loads can be accurately determined only by such methods.

In Great Britain where *plastic-limit* design was recognized as acceptable by the standard specifications (BSS449) in 1948, almost 200 building structures so designed had been built by 1955. Generally great savings in the weight of steel and in cost are possible by this method. The saving in weight is reflected

in lighter and more slender members and has caused at least one American Architect, Philip Johnson — *Architectural Review* Vol. 116 (1954) — who viewed a plastically designed British school building to wonder why comparable designs were not being built in the United States. It is hoped that in the near future such designs will be allowed by American codes and that forward looking engineers will use them to full advantage.

It should be noted that *plastic-limit* design is possible, in practical sense, only for welded frames; also, that the maximum benefit may be derived from welding by *plastic-limit* design. The two are interdependent. Increased confidence in the use of welding will tend to bring greater pressure for building code approval of *plastic-limit* design and, vice versa, approval of *plastic-limit* design methods will see a rapid increase in all-welded building construction.

Plastic Strength of Members

Stress concentrations which result in appreciable local yielding are present in most structures designed by current codes. During fabrication and erection, yield is commonly used in cambering or straightening members or forcing them into place. Experience has shown that these strains do not affect the strength of the structure. If steel did not have the ability to yield under high stress without loss of strength, most steel structures would be impossible to construct.

All the standard specifications have long required that steel used for struc-

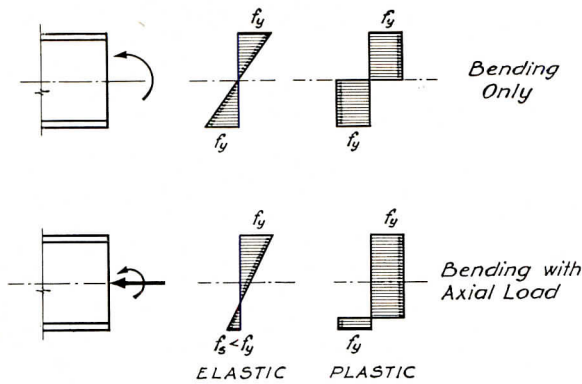

Figure 1. ELASTIC AND PLASTIC STRESS DISTRIBUTIONS

tural purposes be carefully tested to verify its ductility which is often cited as a reason for the reliability of steel structures and the general absence of sudden failures.

Although the actual mechanics of yield and flow of steel are still uncertain and the subject of continued research, the phenomenological or engineering aspects with respect to our present steels have been carefully documented by laboratory tests and experience with full scale structures. At the present time, as a result of research and development work largely over the past 25 years, a rational basis has been established for the use of the plastic strength as a design criteria.

With few exceptions design by the

traditional method of allowable elastic stresses is safe and relatively simple. This was the basis of its introduction in the beginning of the 19th Century and its ready and continuous acceptance to the present. However, as early as 1899, the plastic moment capacity of ductile members was discussed in approximately its present form in a British engineering textbook and has never been completely forgotten.





The difference between the flexural strengths obtained by the elastic and plastic methods is a function of the shape of the section as shown in Fig. 2. Thus, a rectangular section has a flexural shape factor of 1.5 as compared to a wide flange member with a shape factor of approximately 1.14. In other words, the

plastic moment capacity of the rectangular section is 50 per cent greater than the moment at which yield stress is reached at the extreme fiber while the strength of the WF section is only 14 per cent greater.

This involves no great change in thinking for designers, only a different method of computing the required member size, a method which can be introduced readily into most engineering offices. (For the sake of completeness it may be noted that the shape factors shown in Fig. 2 may be modified by shear and axial load.) Moreover, empirical modifications to the current design specifications have anticipated some of the results of the plastic stress distribution. For example the allowable stress for WF beams is 20,000 psi whereas it has been set at 30,000 psi for circular sections. By plastic analysis it is found that the ratio of the ultimate moment capacity to the allowable elastic moment computed with these stresses is approximately the same for both the rectangular and WF sections.

In the design of beam-columns — members carrying moment and axial load — the demarcation between plastic and conventional methods is vague. Much current practice is empirical and is based on elastic theory as modified by test results and experience. More research in this field is needed and is being continued. It is expected that the end result will be more accurate design methods closely related to the plastic buckling strength of beam-columns as determined from modified plastic theory and laboratory observations. As might be expected, research indicates that the present allowable stress design methods are conservative.

Figure 2. RATIO OF FULL PLASTIC MOMENTS TO YIELD POINT MOMENTS

SECTION				
	STRONG AXIS	WEAK AXIS		
SHAPE FACTOR $\frac{M_p}{M_y}$	APPROX. 1.14	APPROX. 1.50	1.50	1.67

M_p = Plastic Moment
 M_y = Yield Point Moment
 (Yield stress at extreme fiber)

Plastic-Limit Design

The most significant change in thinking required by *plastic-limit* design is that the entire structure must be designed as a unit rather than as the sum of a number of separate individual members or sections. Although it is true that in the elastic analysis of a continuous structure the entire structure must be considered in order to compute the moments, thrusts and shears at each section, all the sections are then designed independently. If each section were made adequate for exactly the required strength and no more, the elastic design would be equivalent to a limit design for the same loads. This, however, would involve the use of members of variable section with haunches and/or cover plates. High fabrication costs

make this approach prohibitive for typical construction. If on the other hand, each member consists of a uniform rolled section, say a WF, then conventional design requires that it be proportioned to limit the maximum moment to the section of highest moment to the allowable value. At all other sections the member is stressed to less than its capacity and some metal is wasted.

In limit design a plastic hinge is allowed to develop at the point of maximum moment and to rotate until all critical sections are fully utilized. (A plastic hinge is formed when a section has reached its full capacity and can continue to rotate without change in moment.) Since the load capacity under this condition is greater than that assumed by an elastic analysis, the size and/or weight of the member can be reduced with considerable savings. It can be seen that by allowing even one plastic hinge to develop, the elastic analysis of moments is invalidated. Also, allowing a plastic hinge to develop at any point of a multiply-redundant structure results in increased moments elsewhere. For this reason it is necessary that the strength of the structure be investigated as a unit. The proportioning of members and the design of the overall structure thus become a single operation.

If the loading is always of the same type and is fixed in position, *plastic-limit* design requires that at ultimate load:

1. The bending moment be adequate to provide equilibrium with the applied load,
2. There be a sufficient number of plastic hinges present to allow formation of a collapse mechanism, and,
3. No computed moments exceed the plastic moment capacity.

From these principles have been developed various methods of computing the actual value of the failure load. In the case of a fixed end member, the mechanism scheme can be obtained by placing hinges at the center and at each end. For more complicated structures considerable calculation may be required. For structures with moving or independently varying loads additional criteria are required. Possible modes of failure for a simple rectangular frame are shown in Fig. 4. It can be seen that adequate, ductile beam to column connections are of major importance.

It may be noted that the three criteria listed above make no reference to temperature stresses or relative settle-

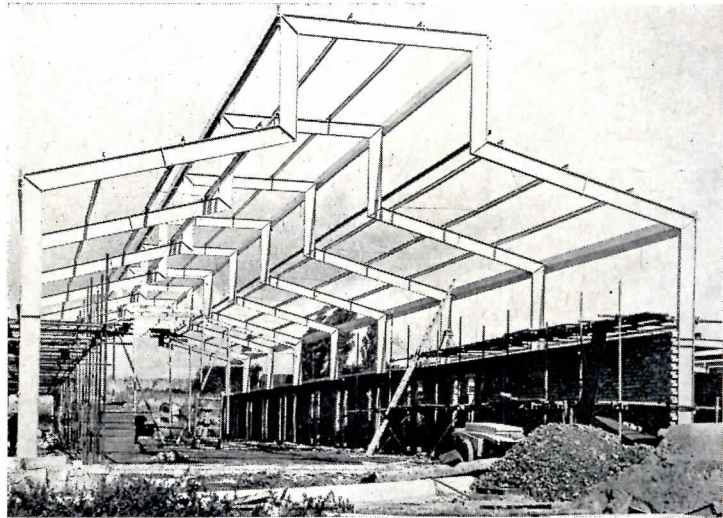

Courtesy American Institute of Steel Construction

Plastic design for research lab in England permitted wide frame spacing, reducing piling costs. Overall savings totalled 23 per cent

ment of supports. Indeed, these two factors which have played so important a part in elastic design theory can be shown to have no effect on the load carrying capacity of ductile structures. Actually, structural continuity is desirable where poor foundation soils are encountered, because, under working load, it provides a means of shifting part of the load from the weak to the strong points of the foundation.

Plastic-limit design eliminates the need for elastic analysis of continuous structures for the determination of strength. For example, a rigid frame designed by current practice requires a complete elastic analysis for the calculation of moments at critical sections. With *plastic-limit* design, the moments

at critical sections are taken at their ultimate values which are reached when plastic hinges are formed at these points. If necessary, the intermediate moments may then be computed from the principles of statics.

Elastic theory must still be used for the calculation of deflections, the plastic rotations at the hinges being superimposed on the elastic curve. For example, the final deflection of a fixed-end uniform section beam under uniform load may be approximated as the elastic deflection of a fixed-end beam for the load which causes formation of the hinges at the ends plus the elastic deflection of a simple beam for the additional load required to form the hinge at the center.

Plastic-limit design requires that the

Figure 3. COMPARISON OF LOAD CAPACITIES OBTAINED BY ELASTIC AND LIMIT ANALYSES

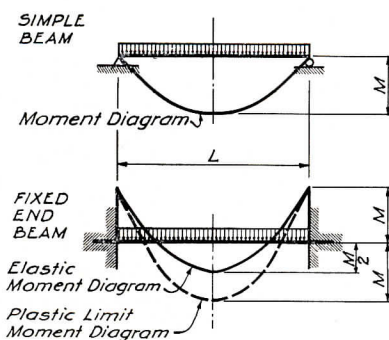

ELASTIC * ANALYSIS LOAD W_e	LIMIT ANALYSIS LOAD W_p	RATIO $W_p:W_e$
$\frac{8M}{L}$	$\frac{8M}{L}$	1.0
$\frac{12M}{L}$	$\frac{16M}{L}$	1.33

* By Moment Distribution or similar methods.
 ** M = Moment capacity of the beam section.

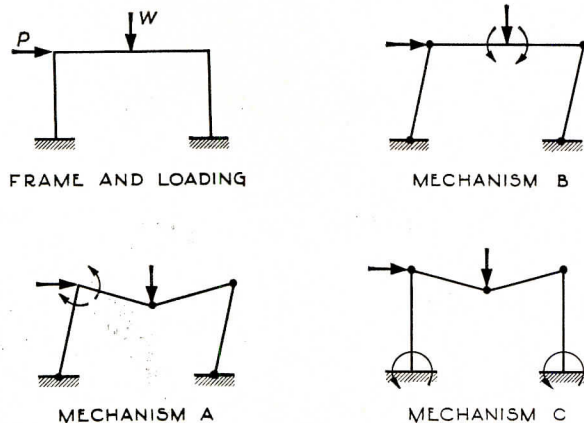

Figure 4. POSSIBLE FAILURE MECHANISMS FOR A SIMPLE RECTANGULAR FRAME

load carrying capacity of the structure be limited only by plastic yielding, the failure being preceded by large deformations and deflections. Careful reflection will indicate that in the event of excessive loading this is the most desirable type of failure since it will usually provide adequate warning so that preventive measures can be taken. In order that failure shall be of this type it is necessary to prevent sudden failures such as may be caused by brittle fracture, fatigue failure or plastic buckling. It is obvious that the first two will result in sudden failure. The third, plastic buckling, must also be avoided or its effects carefully considered by the engineer

In this case, the load capacity does

not remain constant or increase with deflection as in the case of simple plastic bending, tension or compression, instead the resistance of the member to load drops off as shown in Fig. 5. Thus, if a member whose resistance to load is limited by plastic buckling is fully loaded, it becomes unstable and any additional accidental deflection will cause a relatively sudden failure. This, of course, assumes that the load cannot be transferred elsewhere. If this is possible, as it is in most complicated continuous frameworks, failure may be prevented or at least retarded. In any case, the designer must consider the maximum deflection or rotation to which the member will be subjected in determining the failure load. It is desir-

Figure 5. LOAD VERSUS DEFLECTION FOR MEMBERS SUBJECT TO PLASTIC BUCKLING

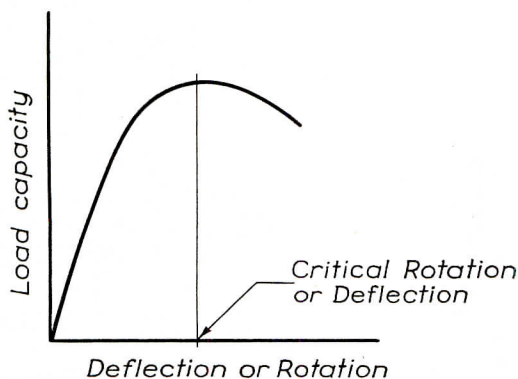

able to avoid the inclusion of such weak points in a structure.

The designer must also guard against the possibility of any substantial number of cycles in which the plastic moments reverse direction as a result of alternating loads. Although further study may tend to improve the picture, it appears at present that such reversals may lead to eventual failure after a relatively small number of cycles. It is interesting to note that the most direct *plastic-limit* design approach in such cases is to start the calculation with a complete elastic analysis.

Because of their dramatic nature, brittle failures often make headlines, as for example the World War II Liberty Ships which split open on the high seas and the all welded viaduct which collapsed in Canada in 1951. These failures are attributed to combinations of extremely low temperatures and steel of unsuitable composition particularly with regard to carbon and manganese. However, the standard structural steel, A7, which is in use in the United States for bridges and buildings, has an excellent record. Where temperatures may reach -30 to -40 F., where thick plate material is required and where restraints against ductile behavior cannot be avoided two new steels are now available to provide a greater margin of safety against brittle failures, A373 Structural Steel for Welding and A131 Structural Steel for Ships.

Where fatigue failures due to a large number of repetitions of load are possible, the stress at failure may be far below the yield point, thus precluding the development of the full plastic strength of the section or the formation of plastic hinges as required for *plastic-limit* analysis. For such cases, the allowable stress method combined with elastic analysis appears the most practical method of design.

Load Factors

The criteria for a satisfactory design by elastic theory are that the allowable stresses are not to be exceeded and that the deflections or other deformations shall be within limits which are not objectionable. If the allowable stress is set at $\frac{\text{Yield Point}}{\text{Factor of Safety}}$, it may be as-

sumed that the actual factor of safety will never fall below that established in the final construction. On the other hand, it is well known that the actual factor of safety may be much higher depending on the shape of the members, the re-

dundancy of the structure and the type of loading.

In the past, the factor of safety has been established primarily on the basis of experience, such that normally well designed, fabricated and erected structures subject to all the normal uncertainties inherent in each step of the construction process would be adequate for their intended usage. It presumes that in a certain number of cases, even where the design load is not exceeded, a combination of faulty material, poor workmanship and careless design will result in failures. The established factor of safety tries to strike a balance such that the losses due to failure will be much less than the cost involved in raising the general factor of safety for all structures.

In proposing a new design method the tendency has been to presume that it would be satisfactory to retain the same actual minimum factor of safety as results from current design methods. However, it must be noted that the factor of safety by *plastic-limit* design becomes uniform for all structures. Although this is desirable, it does mean that the factor of safety of such construction will be in many cases much less than that in construction built from current designs which have factors of safety varying upward from the minimum. In addition, many more points of a structure designed by plastic-limit methods may be stressed beyond yield than are so stressed accidentally at present. Such conditions will affect the resistance of structures to load repetitions and also their resistance to wind and earthquake. In the last two cases, the design loads themselves are the result, to a large extent, of engineering judgment in many cases. This judgment is greatly affected by past experience with structures having variable, usually higher factors of safety.

For these reasons it is desirable to place the selection of loads and load factors on a more scientific basis. Considerable fruitful work has been done in this field in recent years using the theory of probability to determine the expected frequency of live loads, imperfections in material, etc., and adjusting factors of safety accordingly. There is still room for wide improvement in load factors (ratio of collapse load to working load). Unfortunately for designing engineers such improvements are likely to lead to greater complication in design.

It is worth noting that as the variables of doubtful loading, material, workman-

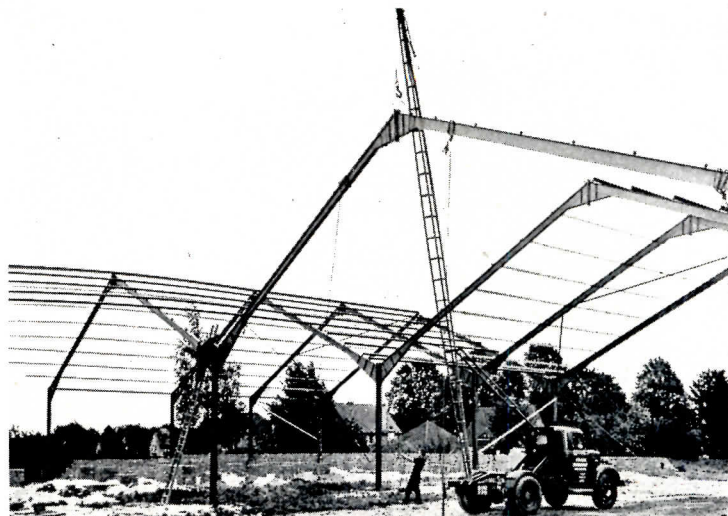

Courtesy American Institute of Steel Construction

Slim, double gable frame for storage building near Andover, England was designed plastically; fabricated by shop welding, field bolting

ship and design are reduced to a minimum by careful control of all operations it becomes possible to reduce the final load factor without impairing the usefulness of the structure. Also, there has been considerable discussion as to the desirability of using different factors for dead load which is a constant known value and for live load which is subject to uncertain variations. Such changes in the controlling specifications are not expected in the near future.

It is expected that when plastic-limit design is included in our building code specifications a load factor of at least 1.88 will be required.

The British Standard Specification adopted in 1948 requires a minimum load factor of 2.00 for *plastic-limit* de-

sign. It states, "[Fully rigid design], as compared with the methods for simple and semi-rigid design, will give the greatest economy in the weight of steel used when applied in appropriate cases. For the purpose of such design, *accurate methods of structural analysis shall be employed leading to a load factor of 2*, based on the calculated or otherwise ascertained failure load of the structure or any of its parts, and due regards shall be paid to the accompanying deformations under working load, so that the deflections and other movements are not in excess of the (normal limits)." Even with these restrictions plastic-limit design has shown substantial economies in material and cost in comparison with conventional design methods.

B I B L I O G R A P H Y

GENERAL

1. *Introduction to Plasticity* by A. Phillips, Ronald Press Company, N. Y., N. Y. (1956)
2. *Inelastic Behavior of Engineering Materials and Structures* by A. M. Freudenthal, John Wiley & Sons, Inc., N. Y., N. Y. (1950)
3. *Theory of Limit Design*, by J. A. Van den Broek, John Wiley & Sons, Inc., N. Y., N. Y. (1948)

REINFORCED CONCRETE

1. *Guide to Ultimate Strength Design of Reinforced Concrete* by C. S. Whitney and E. Cohen, *Proceedings, American Concrete Institute*, Vol. 53, November 1956
2. *Final Report of ASCE-ACI Joint Committee on Ultimate Strength Design, Proceedings, American Society of Civil Engineers*, Paper No. 809 (1956)

STRUCTURAL STEEL

1. *The Steel Skeleton (Vol. 2 Plastic Behavior and Design)* by J. F. Baker, M. R. Horne and J. Heyman, Cambridge University Press (1956)
2. *Proceedings, National Engineering Conference, 1956*, American Institute of Steel Construction, 101 Park Avenue, N. Y., N. Y. (1956)
3. *Plastic Design in Structural Steel* by L. S. Beedle, B. Thurliman, R. C. Ketter, Lehigh University, Bethlehem, Pennsylvania (1955)
4. *Plastic Strength of Structural Members, a Symposium, Transactions, American Society of Civil Engineers*, Vol. 120, Paper No. 2772 (1955)

Note: The above list of publications is only representative and is not intended as a complete bibliography. Many important works are not included.

NEW TYPES OF WOOD ROOF TRUSSES

BY HOWARD E. McCALL

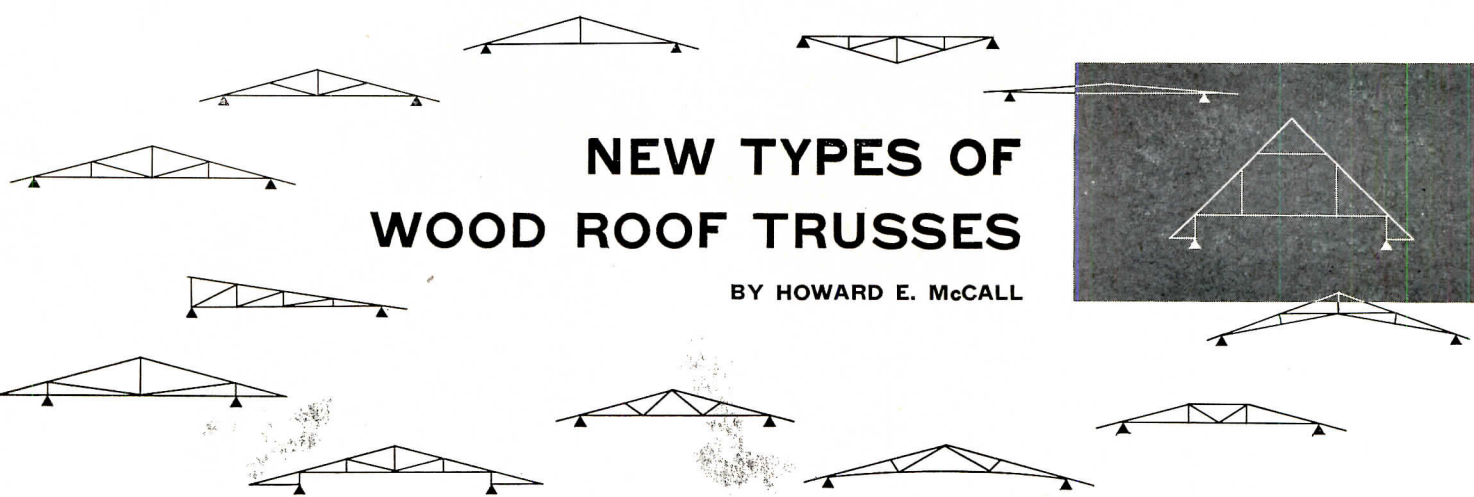
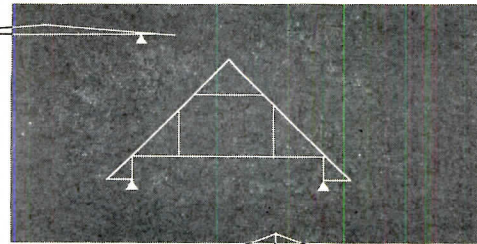

LIGHTWEIGHT WOOD ROOF TRUSSES for houses and small buildings have become increasingly popular in recent years due to the potential savings in materials, labor and overall construction time. Expanding usage has in turn stimulated engineering design, testing and construction methods. Much of the current effort has been aimed at simplifying joint connections and fabrication — for example, reducing the amount of precision cutting required. This article is a review of six newly developed types of trusses, various ones of which can produce the shapes shown above. Details of construction along with a discussion of advantages and limitations are given for each.

A great amount of research has been conducted by various organizations to evaluate the qualities that approach the ideal roof truss, and to establish the limitations of wood structural members used in trusses. The designs shown in this article were developed by standard engineering procedures and full-scale exploratory performance tests to obtain data to meet requirements of building codes and performance standards for roof framing.

A review of the general advantages of roof trusses shows that they (1) allow complete flexibility for interior spaces, (2) save 30 to 35 per cent of materials used in conventional framing, (3) can be fabricated and erected in one-third the time required for rafters and ceiling joists, (4) place the building under cover almost immediately, allowing interior construction to proceed through bad weather, (5) permit interior finish to be applied in one, uninterrupted operation, (6) save material and erection time for interior, non-load bearing partitions, (7) simplify floor construction by eliminating foundation and footings required

for load-bearing partitions and (8) provide easy access for mechanical trades "open room" construction.

For many years, most trusses were built with lapped joint members using bolts, split-rings or nails as the structural connections. These trusses were limited in span and required roof slopes of 4/12 or greater. (At lesser slopes, stresses at the joints become excessive.) Most of the recent developments in truss designs employ a system of joint connection that permits all structural members to be in the same plane. Many advantages are obtained by this: (1) less material, (2) smaller size chord members, (3) simplified fabrication with few special tools required, (4) uniform thickness of all joints permits easy stacking for storage and transportation in less space, (5) lighter weight, (6) simplified erection, (7) roof sheathing and ceiling material can be applied with no problem of lapped chord members, (8) all structural members are in the same plane and are not stressed with eccentric stresses, (9) trusses can be used for roof slopes down to 1/12, and (10) hip-roof truss systems have been developed that allow considerable speed and economy over the conventional methods of framing hip-roofs.

Nailed Trussed Rafter

The design of the nailed truss rafter is based on experimental data obtained at the Virginia Polytechnic Institute, Wood Research Laboratory, by Dr. E. George Stern under the auspices of The Independent Nail and Packing Company. These designs have been thoroughly engineered and subjected to all types of tests. The trusses have proven conclusively to be of ample strength for the use intended.

The heel joint detail uses solid wood splice plates for structural connections. These splice plates must be of sound,

seasoned lumber of 1450f stress grade, and must be selected for proper quality to avoid splitting during the nailing operation. Care should be taken to see that all joints are fabricated according to the design details for a given span and slope. Nail spacing is important in order to develop the greatest strength and to prevent splitting of the splice plate. Helically threaded nails are recommended. If 12^d nails are used, as in the heel joint detail shown, the nail can be driven from one side and will attach the chord member and the splice plate on both sides; thus the nail is loaded in double shear developing its maximum strength. The trussed rafter is most effective when the wood members in a joint are fastened tightly. Since the load at each joint is a shear load, the structural strength depends on proper assembly and good workmanship.

The rows of nails are spaced 3 in. on center and the nails are spaced approximately $\frac{3}{4}$ in. apart in each row. A special template is recommended for nailing the trussed rafters. It is used for each different nailed joint and for each span. A paint spray applied over the template leaves the desired nailing pattern on the splice plate.

In addition to the more common shapes, scissors trusses for a span of 30 ft with a roof slope of 5/12 and a ceiling slope of 2/12 are also available.

Advantages of using these trussed rafters in addition to the general advantages of trusses are: (1) fabrication is adaptable to site conditions without special equipment, and (2) the truss is extremely strong when properly fabricated.

Disadvantages are: (1) the lumber for splice plates has to be carefully selected and (2) because of the large number of nails used, a certain degree of skill and experience is required to nail splice plates without splitting the lumber.

The author is a registered architect from Champaign, Ill., who worked on the development of the University of Illinois Small Homes Council trusses presented in this article.

NAILED TRUSSED RAFTERS

Solid wood splice plates with helically threaded nails
18 to 36 ft spans; 2/12 thru 6/12 roof slopes; 45 psf design load

NAIL-GLUED ROOF TRUSSES AND FRAMES

Plywood gusset connections, nail-glued
20 to 40 ft spans; 1/12 thru 4/12 roof slopes; 40 to 60 psf design loads

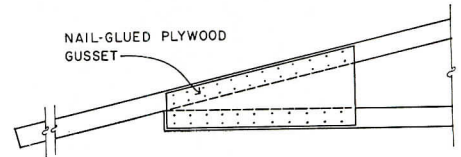
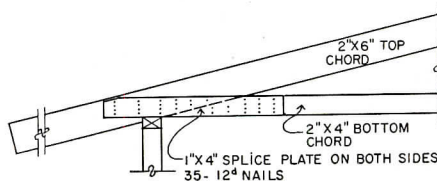
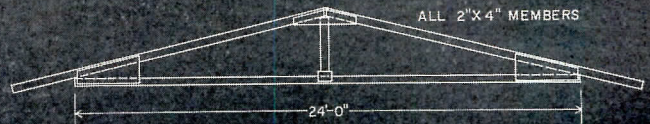
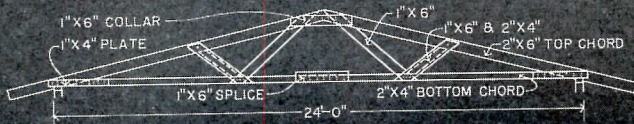

Further information concerning the nailed trussed rafter can be obtained from: Independent Nail and Packing Company, Bridgewater, Mass., and Department of Wood Construction, Wood Research Laboratory, Virginia Polytechnic Institute, Blackburg, Virginia.

Nail-Glued Roof Trusses and Frames

The nail-glued truss was developed in a joint research project between the University of Illinois Small Homes Council and the Purdue University Wood Research Laboratory in 1953. At that time, design specifications for the use of nail-glued connections on roof trusses were established, and with that data several truss designs have been developed for various uses.

Glue as a structural wood connection has been used for centuries and is being used to a great extent today in Europe. In this country structural nail-gluing has been used only to a small degree. The Small Homes Council publications on nail-glued truss designs are believed to be the first presentation of a system of nail-glued trusses to this country's building industry. Builders and truss fabricators immediately gave a warm reception to these new designs because of their simplicity and economy. FHA and other building inspection departments did not respond with an equal amount of enthusiasm, and were hesitant at first with approval of this type truss construction. Their reluctance was due to the fact that field inspection is required to assure proper fabrication, and to the lack of sufficient proof and information on the durability of a glued joint. The system of nail-gluing is now approved by FHA in some areas provided the trusses are fabricated under controlled conditions, which means shop fabrication facilities and a quality of workmanship and material as specified by the designers.

The term "nail-gluing" is used to designate the method of providing pressure to the glued joint while the glue cures. Nails hold the plywood and the structural members in close contact during the period while the glue cures. After the glue has properly cured the nails are not considered as providing any strength to the structural glued joint. The glue recommended for these trusses is a grade A Casein and should be mixed in accordance with the manufacturer's instructions.

The plywood used for gusset plates is an unsanded grade. The 2- by 4-in. or 2- by 6-in. members should be a construction grade of Douglas Fir or a No. 1 grade Southern Pine, both having a stress grade of 1500 psi. Site fabrication is possible but it is not recommended because it is necessary to use a jig and to have a sheltered area to allow the trusses to cure after gluing. All structural members are "square end" cut and do not require beveled cuts for joints — one factor that greatly simplifies the fabrication. The members are placed in the jig and glue is applied to the members by a mechanical glue spreader, a serrated bar spreader or a brush. The plywood gusset is placed on the glue area and nailed with 4^d nails or a mechanical stapling machine using 1¼-in. staples spaced 4 in. on center. Plywood gussets are used on both sides of the joint connection. After the truss has been assembled it must be stacked and left for a period of 24 hours at a temperature not less than 50 F and must be protected from rain during the curing period.

The Forest Products Laboratory has conducted experimental tests on nail-gluing for a number of years and has sufficient evidence to substantiate the strength of nail-glued joints. The University of Illinois Small Homes Council and the Purdue University Wood Research Laboratory has been conducting

performance tests on these truss designs for three years. Many of the tests have been conducted under the severest possible conditions to establish data for determining the strength and durability of nail-glued joints.

Some of the advantages in addition to the general ones obtained by using roof trusses are: (1) no precision cutting — all members are square end cuts, (2) extremely simple geometry is obtained by using rigid gussets, (3) light weight, stronger than nailing, (4) low slopes.

Disadvantages are: (1) Requires shop fabrication, and a curing period of 24 hours, (2) nail-glued trusses are statically indeterminate and cannot be structurally analyzed to develop designs for special conditions.

Nail-glued roof truss designs are available from the Small Homes Council, Mumford House, University of Illinois, Urbana, Illinois, in the following types:

- Plywood Web Roof-Frame
1/12 roof slope; 20 ft-8 in. to 28 ft-8 in. spans
- Sloped Ceiling Plywood Web Roof-Frame
3/12 roof slope & 1.5/12 ceiling slope;
21 ft-0 in. to 32 ft-8 in. spans
- King Post Trusses
2/12, 3/12, 4/12 roof slopes
18 ft-0 in. to 24 ft-8 in. spans with 2 in. by 4 in. members
25 ft-0 in. to 32 ft-8 in. spans with 2 by 6 in. members
- "W" Trusses
2/12, 3/12, 4/12 roof slopes
20 ft-8 in. to 28 ft-8 in. spans with 2 by 4 in. members
29 ft-0 in. to 40 ft-8 in. spans with 2 by 6 in. members
- Hip Roof Trusses
3/12 roof slope; 20 ft-0 in. to 28 ft-8 in. spans

The Ring-Nail "W" Truss

Split ring connectors have been used for many years as timber connectors in wood frame structures as well as roof trusses. Design specifications for the use of split ring connectors are available in

THE RING-NAIL "W" TRUSS
 Split ring and nailed connections
 Spans of 20 ft 8 in. to 32 ft 8 in. Roof slopes
 of 3/12, 4/12 and 5/12; 43.5 to 55 psf design loads

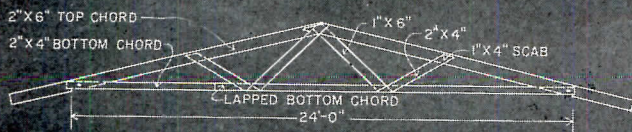

SPLIT RING & BOLT AT PEAK
 & HEEL JOINT. OTHER NAILED

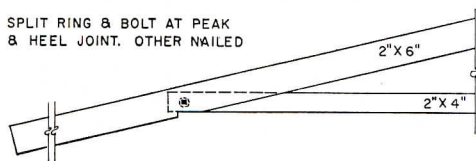

a number of publications on wood fastenings which allow the architect to design for almost any condition. Many truss designs using this type connection have been developed by The Timber Engineering Company. The ring-nailed "W" truss discussed here was developed by the University of Illinois, Small Homes Council.

Three joints use split-rings in this design — at each heel joint and at the peak joint. Other members are connected by nails. This truss does not have all structural members in a single plane, thus there is a certain degree of eccentric stresses in the members. One of the main considerations in developing this truss design was to minimize the number of precision cuts required on the members. This was accomplished by using only one notched cut at the heel joint, an angle cut on each end of the diagonal members. The balance of the truss has flat joints and will allow small deviations in the length of members. The 4/12 and 5/12 trusses can be fabricated in one complete unit or they can be subassembled in sections. The split ring connections are bolted loosely so that the truss folds together. Short diagonals, one end of the long diagonals and chord sections are nailed together at the site.

Trusses built from this design have received FHA acceptance. Design loads and stresses for these trusses are easily calculated because of the assigned value to the loads carried by the split rings and nails. These trusses must be built with a camber in the lower chord, and are not as strong as some of the other trusses described in this article.

Further information concerning this truss design can be obtained from the Small Homes Council, Mumford House, University of Illinois, Urbana, Illinois.

Gri-P-late Trusses

The Sanford Grip-P-late connections

GRI-P-LATE TRUSSES
 Perforated 20 gage steel plate connections
 Spans up to 50 ft; 2½/12 thru 5/12 roof slopes; 60 psf design load

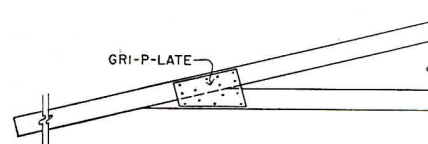
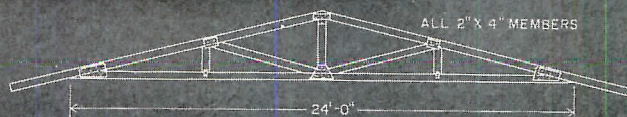

and the Sanford roof trusses are patented designs developed by Mr. A. Carroll Sanford, architect and engineer, from Fort Lauderdale, Florida. The Grip-P-late is an electro-galvanized steel plate perforated with ¼-in. deep angular teeth. There are two teeth per square inch that develop a holding power of 100 lb per sq in. of steel surface area.

The Sanford Gri-P-late is not a connection that can be purchased from the market. Fabricators of the Gri-P-late trusses must meet strict specifications covering workmanship and material. This truss is one which can be purchased from the fabricator ready for erection.

The Sanford trusses are fabricated in a hydraulically controlled jig that presses all structural members into firm contact. The Gri-P-late is placed on both sides of every joint. The plate is nailed approximately 4 in. on center with 1½-in. strong hold, angular threaded shank nails. The truss is then moved to a standard 50 ton press where each Gri-P-late is stamped. This operation presses the ¼-in. angular teeth and nails into the wood truss members at each face of each joint and produces a positive mechanical connection. The Gri-P-late connection produces a truss that is extremely strong and has been tested by various testing laboratories throughout the country. These trusses have VA and FHA acceptance on a national basis.

The Sanford trusses have been in existence for about two years and have licensed fabricators in some 24 areas of the country. Advantages of Sanford trusses include: (1) they are lightweight and easy to handle, (2) they stack good for storage or transportation and (3) they are available in a great variety of types to meet special conditions.

In addition to conventional shapes, hip-roof trusses are also available for various slopes and spans up to 32 ft.

This system of connections is not one that can be fabricated in the field. The trusses must be purchased through licensed fabricators and distributors. For further information concerning this type roof truss, address inquiries to Sanford Gri-P-late Co., P. O. Box 4426, Fort Lauderdale, Florida.

H-Brace Roof Trusses

The H-brace metal coupling was developed during 1953 by a millwork organization that had several years experience fabricating various types of trusses. The H-brace connection is a patented device and to date has not been sold to jobbers and retailers. H-brace trusses are available only through qualified prefabricators, millwork and lumber dealers. To date most of the qualified prefabricators of H-brace trusses are located east of the Mississippi, and can be found in many parts of the Middle West, Northeast, and the South.

The H-brace connection is a 20 gauge galvanized steel coupling bent into the shape of an "H" from one single piece of metal. The coupling has holes pre-drilled which automatically establish the nailing pattern. The couplings come in three different sizes to be used for joints having all members of one size or a combination of two sizes of wood members. In addition there are other connections of similar design for splice plates and regular flat plates. With these connections all structural members are in the same plane.

The structural members of the truss are pre-cut to exact sizes. The members and H-brace connections are placed in a truss jig and pressure is applied mechanically or by wood wedges to place all members in firm contact. The metal braces are nailed with 1½-in. long nails. Several nail types can be used, but 0.105 gauge, galvanized, helically grooved common nails are recommended. Shank

H-BRACE ROOF TRUSSES

One piece steel connection fastened with nails
20 to 38 ft spans; $2\frac{1}{2}/12$ thru $5/12$ roof slopes; 55 psf design load

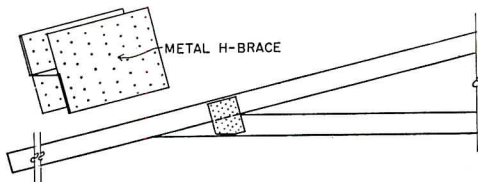
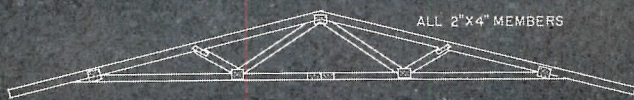

penetration of 91 per cent is obtained by using these metal plates.

H-brace trusses have a great amount of strength. These designs have been tested by accredited laboratories and various university engineering departments and have been accepted by VA and FHA loaning organizations and building departments wherever presented for acceptance.

In addition to having the general advantages of roof trusses, the H-brace truss: (1) permits an efficient fabrication operation with the metal brace used as a nailing template, and (2) gives a lightweight, very strong truss which stacks well for storage and transportation.

The availability of this truss through a licensed fabricator is a factor to be considered. For further information about H-brace, contact: H-BRACE, Inc., P. O. Box 6036, West Palm Beach, Florida.

Nailed Plywood Gusset Plate Trusses

The development of this truss type is not accredited to any particular person. The method has been used for several years by many people throughout the country. This is one truss that was not developed through a research organization or manufacturer, therefore, design and performance data with recommended details has not been collected and published. Design procedures for this truss are simple and straightforward. A complete structural analysis can be made according to accepted methods and presented to building officials for approval. It will be up to the architect to design for the conditions of his job and to conduct performance tests if necessary to obtain acceptance.

A few nailed plywood trusses have been tested by accredited testing laboratories. These tests have shown that nailed plywood connections when properly designed are sufficiently strong for

use in wood roof trusses. The author has conducted performance tests on a design similar to the one illustrated and found its strength to be above average compared to similar trusses using other type connections.

The nailed plywood gusset truss is particularly good for short spans and can be used up to 30 or 32 ft with a roof slope of $4/12$ or greater. Span, slope, and design load will be the factors in determining the required member sizes. Generally, for spans below 20 ft the geometry can be a simple king post with 2- by 4-in. members. Up to 26 ft the truss geometry can be the "W" or Howe design. Two by 6-in. members will be needed for the top chord in spans above 26 ft, but this will depend on the slope and design load required.

Attic space is best obtained with a "W" truss. The Howe truss is generally stronger than the "W" truss, but the attic storage is very limited. For higher roof slopes it is advisable to design house trusses for attic storage.

Structural joints with nailed plywood gussets should be designed in accordance with the accepted specifications and design data for the use of nails and plywood. Standard engineering principles are used for structural analysis of a design, and for all practical purposes it can be assumed that the truss is pin connected. Trusses with nailed plywood gussets are not generally recommended for slopes lower than $4/12$, but can be used, however, if special consideration is given to the design of the heel and peak joints. There is a tendency for designers to make gusset sizes larger than necessary just to be safe. Over-designed gusset sizes will do more harm than good. Heel gussets should have adequate area to resist the imposed shear, but should also be kept to a minimum length. If heel gussets are made longer than necessary the secondary bending stresses

NAILED PLYWOOD GUSSET PLATE TRUSSES

Connections of nailed plywood gusset plates. Spans up to 30 ft; roof slopes of $4/12$ and greater; design loads up to 60 psf

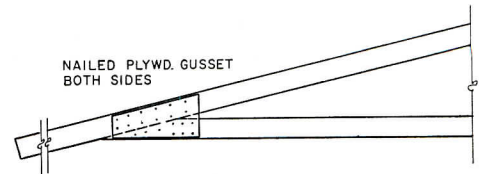
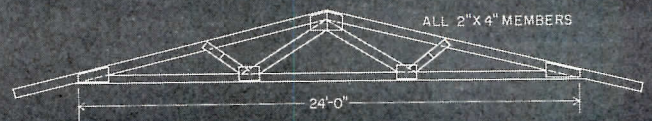

in the top chord will cause an uneven distribution of stresses throughout the nails causing poor performance.

The wood members for these trusses should be at least a 1500f stress grade lumber, and for special conditions where high stresses are encountered a 1900f stress grade can be used. The plywood gussets can be nailed by one of two methods: (1) direct nailing of each gusset and (2) clinched nailing.

Direct nailing of each gusset requires 6 or 8^d nails with a spacing of approximately 3 in. on center. The nails are driven through the plywood into the structural member; therefore, the nails are stressed in single shear. During fabrication the structural members are placed in the jig and the plywood gussets are nailed to the truss. It is turned over and the gussets are nailed to the other side. No special equipment is required for this method and the jig can be of the simplest form.

The method of clinch nailing allows a faster fabrication technique, but it requires flat steel plates in the jig under each gusset plate. During fabrication, members are placed in the jig with gusset plates on both sides in the proper position. 10^d nails are driven into the plywood gussets at a slight angle from the perpendicular. After passing through the structural member and each gusset, the point of the nail strikes the metal plate of the jig and is clinched into the surface of the plywood gusset. The clinched nail is stressed in double shear and holds the three members in close contact.

To determine the number of nails for each joint it is first necessary to make a stress analysis of the truss to learn what loads will be imposed on each joint.

The advantages of using the clinched nail are: (1) all nailing is done from one side of the truss and (2) fewer nails are required.

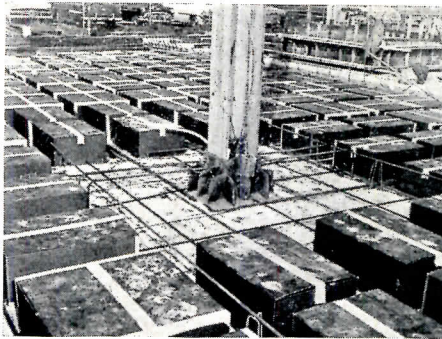
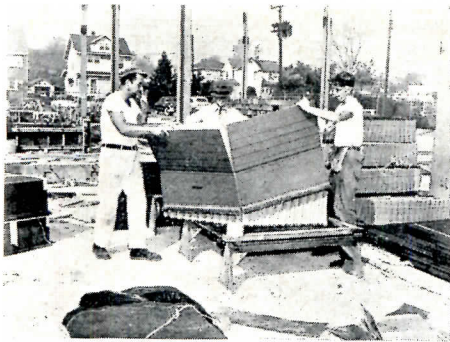

Fibre board boxes, shown during assembly and after placing, give "waffle" shape to slab, eliminate expensive wood forms and bracing

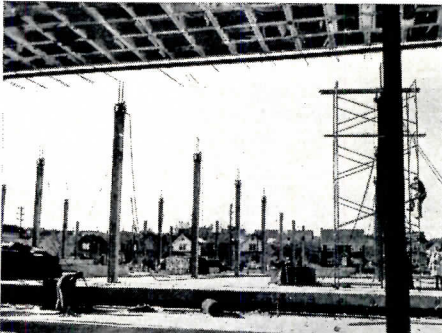

Slab was poured and raised in three sections. Center slab, the largest ever raised, weighs 1400 tons, and has an area of 32,600 sq ft

LARGEST, HEAVIEST LIFT SLAB POURED FOR NEW JERSEY PLANT

THE FIRST LIFT SLAB roof structure to be raised in the metropolitan New York area has set a record as the heaviest and highest clear span concrete roof slab ever to be lifted. A relatively new method for industrial buildings, the lift slab technique has made possible a 1466-ton concrete roof with an area of 32,600 sq ft for the Standard Tool & Manufacturing Company in Lyndhurst, N. J. Two other roof sections of the new plant each weigh 1020 tons and measure 22,400 sq ft in area.

New York architects Powers & Kessler, who designed the building, claim that it is unique in many ways. Not only is it the heaviest lift slab ever raised, but also it is supported on columns spaced on 40-ft centers instead of standard 24-ft centers, thus affording much more open area for production lines, and it has a clear height of 26 ft 5 in. above the floor instead of standard heights of from 8 to 15 ft. The lower costs resulting from this construction system, according to structural engineers Garfinkel & Marenberg of New York, provided a large-span fireproof building for about the same cost as a non-fireproof structure built by standard construction methods. This record was achieved not just by eliminating expensive concrete wood forms and bracing but also by keeping the quantities of concrete and reinforcing steel used with-

in economical limits and by restricting the loads lifted at each column to the rated capacity of the lifting equipment.

The slab itself is a "waffle" shape, with a total depth of 16 in. and a "waffle" depth of 13 in. The waffle shape was attained by using corrugated cardboard boxes as fillers. The waterproof boxes, braced with honeycombed cardboard partitions to prevent deformation due to the weight of the set concrete and other construction loads, were 34 by 34 by 13 in., although they can be manufactured to any size desired. With 6-in. ribs between boxes, a pattern of 12 ribs in each direction per column panel was created. Into this symmetrical ceiling layout was coordinated the lighting, sprinkler and monorail systems. Since there are no trusses or other obstructions in the ceiling, pipes, ducts and cranes can be run continuously in the same horizontal plane. Maintenance is reduced because of the minimum number of steel members that must be painted.

A concrete with expanded shale aggregate, which is one-third lighter than ordinary stone concrete, produced a strong slab equivalent in weight to a 6-in. slab of ordinary concrete. It not only reduced the weight of the slab but also, according to the ratings of the National Board of Fire Underwriters, doubled its fire resistance. This in-

crease in fire resistance added another economy to the building in the nature of added usable space. The amount of setback required on all sides of the building as a fire separation precaution was less than would have been necessary with the next most effective noncombustible type of construction and so permitted the addition of 10,000 sq ft of plant area.

The design strength of the concrete was 3000 psi, although test cylinders indicated the actual strength to be as high as 5000. The weight of reinforcing steel in the slab came to 6 psf.

Hydraulic jacks on top of the 24 wide-flange steel columns lifted the massive concrete roof. The two smaller roof sections were lifted separately, with a gap of approximately 9 in. between each of the three sections. After all three slabs had been raised, concrete was poured into the gaps.

The architects are now working on still more advanced ideas of cost saving and flexibility in fireproof structures — including more functional use of cast-in-place slabs, reduction of work in other trades after the slab is lifted, new methods of hanging and supports for piping, new means of including insulation in the basic slab, and using the mass effect of the structure for summer cooling.

(More Round-up on page 242)

STEEL DOOR FRAME DETAILS — 1: Introduction and Base Plate Details

PLASTER CRACKING

The control of chip cracking of plaster at steel door frames requires simple attention to a few details in design and specifications. If the door frame is free to twist upon impact or the trim returns are free to vibrate, the movement of the frame will loosen small pieces of finish coat and base coat plaster, and unsightly spalling will result.

The following comments and sketches illustrate the improper elements as well as the suggested recommendations, which are the result of field inspection of good and bad installations together with laboratory and field experiments.

The basic considerations are relatively simple:

1. The frame must be securely anchored in place.
2. The partition must enter the frame so that the two work as a unit. This includes both the structural elements of the partition, the plaster base and the plaster.
3. Vibration of the frame, especially the trim returns, must be dampened.
4. The steel door frame must be sufficiently wide to allow full plaster grounds.

Ear cracking off the corners of a door frame is not controlled as easily as chip cracking. The cause of ear cracking is difficult to isolate. It occurs in reinforced concrete walls, masonry walls and lath and plaster constructions. Apparently impact

alone is not the cause since cracking will occur over the openings prior to installation of the doors.

The continuity of the wall or partition is broken by the opening and the weakest plane of the construction is at the opening. Ear cracking can be minimized by attention to the construction at the head of framed opening; the following details are important:

Masonry

1. Workmanship — Masonry units should be laid up with proper bond, full mortar bed and end joints.
2. Lintels should be used over all openings and not supported by the head of the steel door frame. The lintels should extend out from the door jamb sufficiently to eliminate a weak vertical joint adjacent to the face of the door jamb.
3. Reinforce the base coat plaster at the corner of door frame by using self-furring metal lath, 12 in. by 18 in., diagonally at the corner. The dimple of the self-furring metal lath holds the mesh out into the face of the base coat plaster, where the reinforcement is needed.

Studs (Steel or Wood)

1. Gypsum Lath in 16 in. by 96 in. sheets should be used over door frames to eliminate butt joints over or closely adjacent to the door frame.
2. Reinforce the base coat plaster by stapling a 12 by 18-in. piece of self-furring

metal lath diagonally over the corners of the door frame. The self-furring metal lath will hold the mesh out at the face of the base coat plaster where the reinforcing is effective. Conventional diamond mesh lath flat against the lath is ineffective.

PLASTER GROUNDS

Masonry Partitions — Plaster grounds on all masonry partitions are 5/8 in.

Metal Lath — Plaster grounds are 5/8 in. from the face of the metal lath. Diamond mesh metal lath and plaster totals 3/4 in.

Gypsum Lath — Plaster grounds are 1/2 in. from face of lath; plaster and lath = 7/8 in.

Note: Because gypsum is rigid and can be held away from structural members by attachment shoes, wire ties, etc., the overall thickness of the gypsum and plaster over steel studs must be detailed as 1 in.

PARTITION THICKNESS

Masonry	Partition
3 in.	4 1/4 in.
4 in.	5 1/4 in.
6 in.	7 1/4 in.
8 in.	9 1/4 in.

Steel Studs	Gypsum Lath or	
	Dia. Mesh Lath and Plaster	3/8 in. Rib-lath and Plaster
2 1/2 in.	4 in.	4 1/2 in.
3 1/4 in.	4 3/4 in.	5 1/4 in.
4 in.	5 1/2 in.	6 in.
6 in.	7 1/2 in.	8 in.

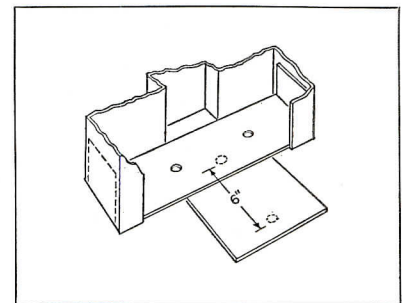
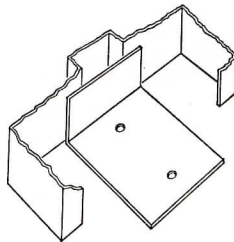
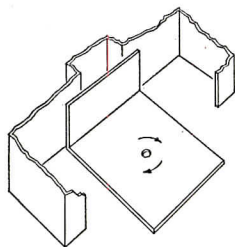

BASE PLATES

Very Poor (Top left) Single pin allows door frame to pivot on impact. Trim returns acting as plaster stops are free to vibrate on impact. All contribute to chip cracking and plaster spalling

Poor (Above) The double pin resists twisting of frame; since it is only attached to the jamb face it leaves trim returns free to vibrate on impact

Very Poor (left) Double pin holds the base plate from pivoting but the frame is anchored at one edge and twists. The end trim return is free to vibrate on impact

Good Base plate anchored to both trim returns with double pins resists twisting of frame and dampens vibration of trim returns. Powder actuated drives require clearance for the gun; T-shaped base plate may be required

ANCHORAGES

Very Poor Concrete nails have short penetration and cause spalling making a very insecure attachment

Very Good Ackerman, rawl or plastic screw anchors provide secure attachment

Very Good Powder actuated drives provide secure anchorage



BORDEN
First IN FLOOR GRATING

BORDEN MANUFACTURES EVERY TYPE FLOOR GRATING

IN FERROUS AND NON-FERROUS METALS

- **EASY TO INSTALL** — engineered in conveniently sized units for easy installation.
- **EXTRA STRONG** — reinforced, designed with maximum safety factor.
- **LIGHT WEIGHT** — approximately 80% open, reduces dead weight, allows greater live load.
- **SELF-CLEANING** — creates greater safety, economy of maintenance, no sweeping or washing required.

Write for complete information on BORDEN All/Weld, Pressure Locked, and Riveted Floor Gratings in this FREE 8-page catalog

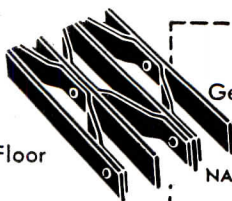

BORDEN METAL PRODUCTS CO.

822 GREEN LANE ELIZABETH 2-6410 ELIZABETH, N. J.
 SOUTHERN PLANT—LEEDS, ALA. — MAIN PLANT—UNION, N. J.

BORDEN METAL PRODUCTS CO.

Gentlemen:

Please send me BORDEN Catalog

NAME

TITLE

COMPANY NAME

ST. AND NO.

CITY AND STATE

STEEL DOOR FRAME DETAILS — 2: Insert Details

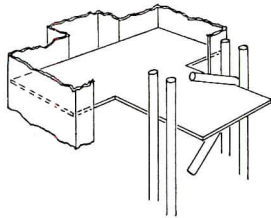

Very Poor Wire tying a stud strut to a loose masonry anchor makes an insecure attachment. The stud is outside the frame and will not resist twisting. The anchor doesn't prevent vibration of the trim returns

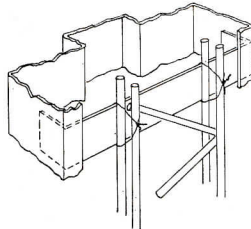

Poor Strap insert ties the trim returns together and dampens the vibration, but saddle tying the strut to the flat strap does not prevent the frame from sliding on impact

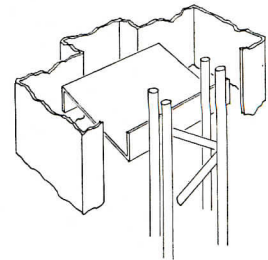

Very Poor The Z-shaped clip provides poor anchorage for the strut and fails to tie the trim returns together

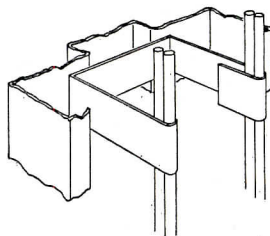

Very Poor Wrap around strap allows frame to shift on impact, and the trim returns are free to vibrate

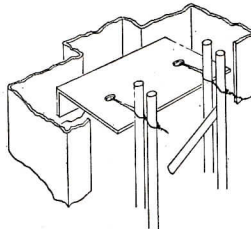

Poor Short insert clip provides good secure anchorage as notched and tied to the stud strut; however trim returns are again free to vibrate

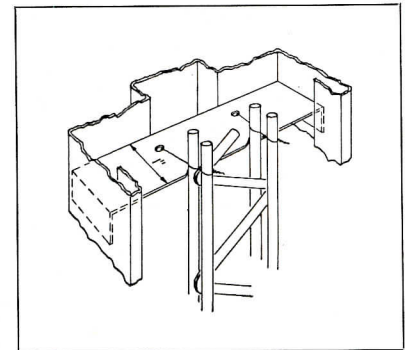

Very Good Jamb anchor insert is welded to the trim returns, dampening any vibration from impact. Notched clip holds the stud strut which is securely anchored by saddle tying.

The clip allows the strut to be set into the frame, reducing the turning moment on impact.

For large openings and heavy doors this frame can be grouted, embedding the strut in the mortar column.

The 180° return on the trim allows both lath and plaster to be let into the frame.

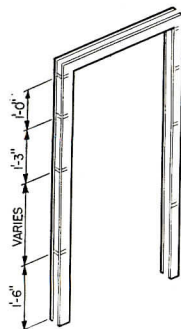

Good Minimum of four insert anchor clips spaced as dimensioned. For larger frames and heavier doors, use additional insert anchors and grout

**ONE
GUESS**

**which acid proof drain pipe
was installed...**

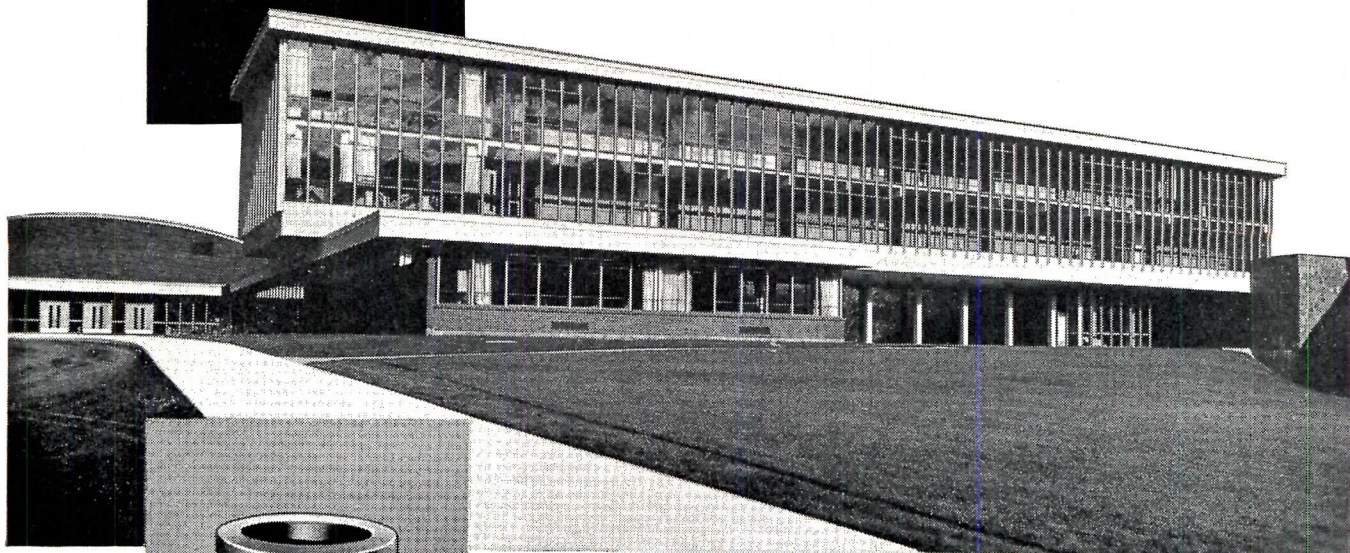

Kellogg High School, Kellogg, Idaho

Architects: Culler, Gale, Martell & Norrie; Spokane, Wash.
Perkins & Will; Chicago and White Plains, N. Y.
General Contractor: Johnson, Busboom & Rauh; Spokane, Wash.
Plumbing Contractor: Detweiler Bros.; Twin Falls, Idaho

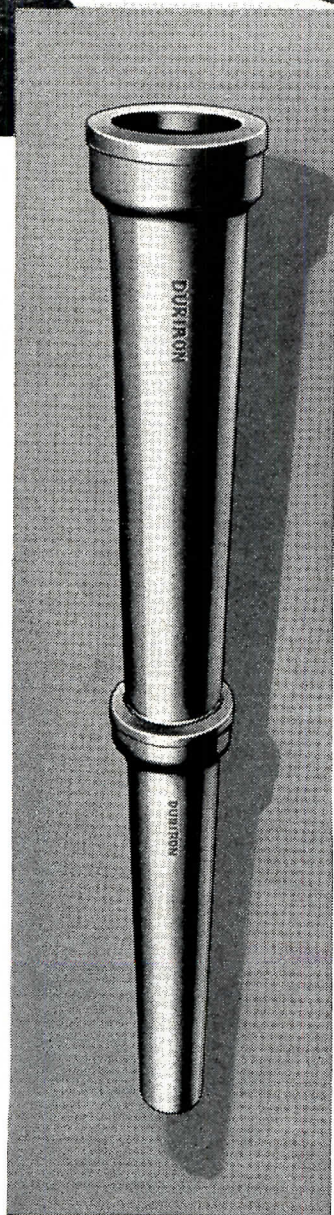

DURIRON®
**CORROSION RESISTING
DRAIN PIPE**

The really permanent one, of course—Duriron. It's the one specified for more than 30 years by architects and engineers who recognize it as the perfect protection for a quality job. Not a coating, Duriron offers resistance to virtually all commercial acids and corrosive solutions . . . throughout the entire pipe wall. Duriron is installed by ordinary plumbing methods and is carried in stock by leading wholesalers everywhere. Insist on *Duriron*.

THE DURIRON COMPANY, INC.
DAYTON, OHIO



STEEL DOOR FRAME DETAILS — 3: Cross-Section and Header Details

CROSS-SECTION

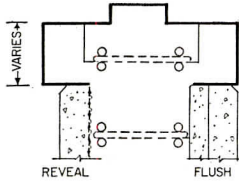

Very Poor Wide flange return acting as a plaster stop prevents the partition and frame from acting as a unit

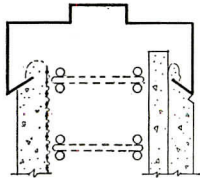

Poor While the plaster mortar keys slightly into the frame, the mass is limited and plaster can be chipped off

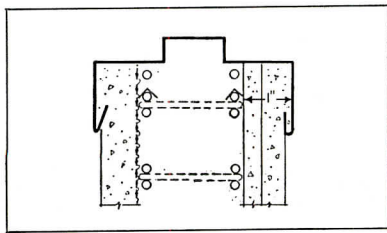

Good Lath and plaster entering the frame provides mass, strength and rigidity to the construction of the frame

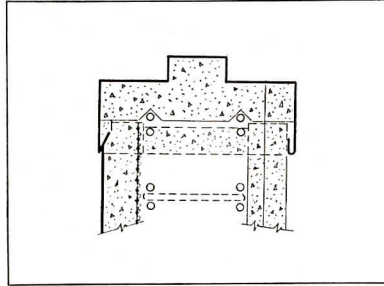

Very Good Grouting the frame and embedding the stud strut in the mortar is necessary for opening exceeding 3 ft-0 in. Grout must be raked out (dashed lines) to recess lath and base coat plaster into the frame

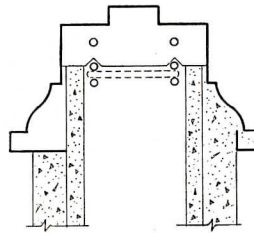

Special attention must be given to dampening vibration of long trim returns. The stud strut should be set well into the frame to resist the twisting action, and lath and plaster must enter and have sufficient mass to grout the returns

HEADER

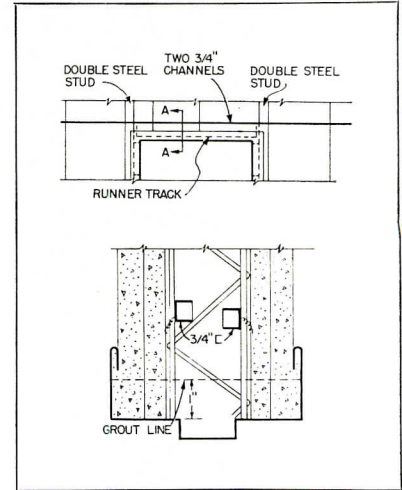

Good 3/4 in. angles, saddle tied to the stud chords with the lath and plaster entering the frame stiffen the stud struts

Very Good Identical to above, but the head grouted, embedding the ends of the studs. Lath and base coat plaster should meet the grout (see dashed line)

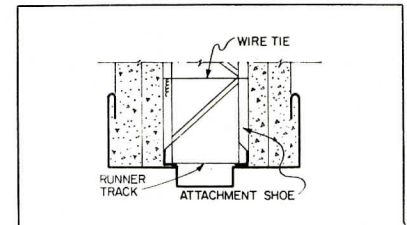

Good The runner track as a header, turned up and wire tied to the stud strut. Attachment shoe holds studs in place

DETAILS FOR OPEN WEB STEEL STUD PARTITION

Cross-Section for
Doors under 3 ft.

Head

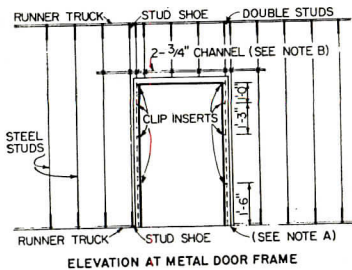

A. Base plate of the door frame to be welded to the trim returns and must be double-pinned to resist twisting

B. Channels should be wire tied to stud chords on each inside face

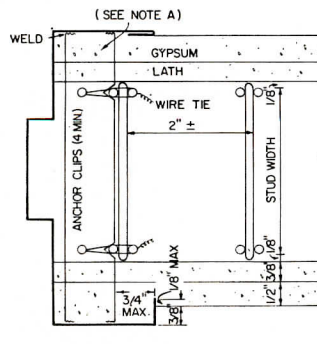

A. Gypsum lath and base coat plaster should carry into door frame as shown

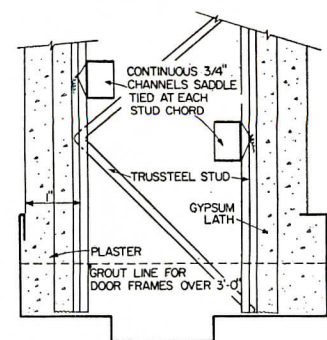

Even when it's zero, there's enough heat in the outside air .



Now! York heat pump takes warmth out o

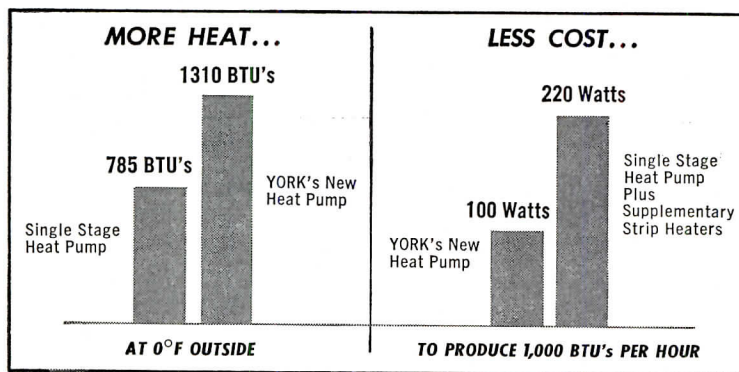

MORE HEAT AT LESS COST! As shown in the chart left YORK'S new air-to-air heat pump system* produces 67 1/2% more heat at 0°F outdoor temperature than the former single-stage system of the same mechanical displacement. To supply the same heat output with the single-stage system would require supplementary strip heating and total wattage requirement would be 120% greater per 1000 BTU than YORK'S new compressor system.

*Patent applied for.



FIRST MAJOR INSTALLATION was at Heironimus department store in Roanoke, Va. served by the Appalachian Power Co. of The American Gas and Electric System.

Hayes, Seay, Mattern and Mattern, Architects and Engineers; B. F. Parrott and Co., Contractor.

NEW BUILDING for Ballinger Co. of Philadelphia features York heat pump, and is served by The Philadelphia Electric Co.

Ballinger, Architects and Engineers; J. S. McQuade, Jr., Contractor.

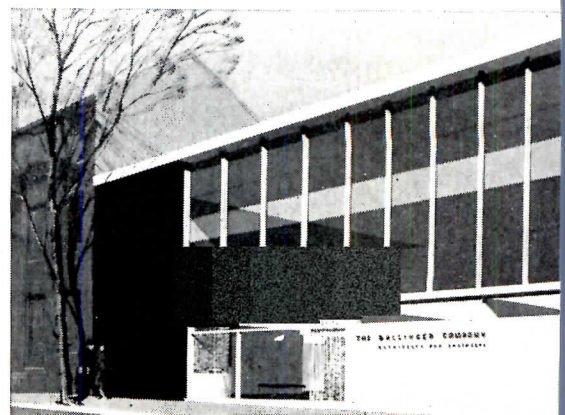

. to heat every room in your building!



sub-freezing air to heat an entire building

DRAMATIC ADVANCE MAKES HEAT PUMP PRACTICAL—WITHOUT SUPPLEMENTAL HEATING

The development by York engineers of the first practical heat pump to use below-freezing outside air promises convenient, more economical year-round air conditioning with a single system. No longer will supplementary strip heating equipment be needed in areas where winter temperatures drop below freezing.

The big difference in the York heat pump is that it takes advantage of a long-utilized refrigeration technique, compound compression. The system is operated by thermostatically controlled valves. These valves guide hot or cold water in and out of the system while compressors automatically move from single-stage compression into compound compression when the temperature drops below a certain point. Now that the high-operating-cost problem of auxiliary strip heating,

needed where temperatures drop much below 32° F., has been eliminated, builders and owners can offer customers year-round air comfort at lower annual cost.

Electric Utilities faced with uneconomical air conditioning load factors will now be able to profitably promote the heat pump above the Mason-Dixon line. Until now the high operating cost of the air-source heat pump has limited application in Northern areas. But elimination of heat pump capacity deficiencies at low temperatures and removal of the very low load factors of strip heaters makes the new system attractive to both user and utility. For full details on the York heat pump write: York Corporation, subsidiary of Borg-Warner Corporation, York, Pennsylvania.



the quality name in air conditioning

HEADQUARTERS FOR
MECHANICAL COOLING SINCE 1885

YORK
CORPORATION

(Continued from page 230)

RESEARCH SCHOOL WILL TEST CLASSROOM TEMPERATURES

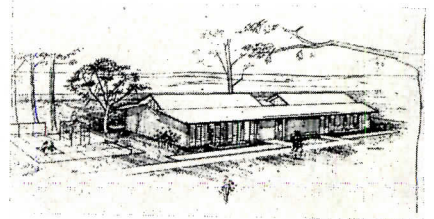

A two-classroom school building in Des Moines, Iowa, will begin standard schoolroom operations in the next month or so with the express purpose of testing a new heating and fresh-air system for schools. Financed by Lennox Industries, Inc., as a research project, the school was designed by R. C. Ovresat, AIA, and Perkins & Will, Architects, with consideration of the many complex problems of classroom heating not only in design of equipment but also in design of the school building itself. The architects have included modern concepts of lighting, seating, storage and exhibit space, chalkboard locations, and teacher and student conveniences, combining them with such practical considerations as consolidation of plumbing and elimination of ornate decoration so as to offer maximum utility at minimum expense.

The new "Comfort Curtain" heating and fresh-air system used in the school is the result of four years of intensive research into the problem of maximum classroom comfort at a minimum of cost. Based on the proposition that an occupied schoolroom is more often a cooling problem than one of heating, because of the heat produced by the lighting, by the sun in certain exposures and by the students themselves, the system is designed to make almost instantaneous changes from maximum heat delivery to maximum fresh air. It blends fresh air with heated air continuously

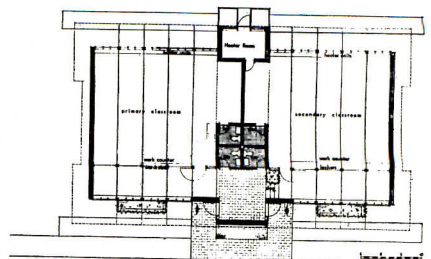

LENNOX CLASSROOM PROJECT DES MOINES IOWA
R. C. OVRESAT, AIA, ARCHITECT PERKINS & WILL CONSULTING ARCHITECTS

New & Unique

fully automatic — instantaneous

EMERGENCY LIGHTING SYSTEM

Always on Guard 100% Dependable

The only system of its kind listed by
UNDERWRITERS' LABORATORIES, Inc.
Exceeds Requirements of the **NATIONAL ELECTRICAL CODE**

A complete, self-policing emergency lighting system that guards against costly confusion or panic caused by sudden darkness.

Takes over in a split second! The instant power fails for any reason, at any time, Standard's centralized system goes to work automatically — provides instantaneous Emergency Lighting in effected areas. Work schedules or business continues without interruption.

Always on Guard! 100% Electrically Supervised. Standard's Emergency Lighting System *protects itself* against human neglect or accidental disarrangement. Should anything in the system go wrong, doubly supervised circuits go into action instantly! A burned out lamp, accidental damage, or even a light fingered bulb snatcher — is reported to the Area Control Panel. Buzzers buzz! Lights light — and the trouble can be corrected before a lighting emergency arises.

Always on Guard! The Flexlab Nickel-Cadmium, alkaline battery has an expected life of more than twenty-five years, requires near-zero maintenance, does not corrode like lead-acid batteries.

This new and unique Emergency Lighting System is streamlined, good looking, designed to match the decor of modern buildings. Centralized power and control, concealed wiring and handsome fixtures replace box-on-the-wall units. Standard's Emergency Lighting System is built-in just like the fire alarm and sprinkler systems.

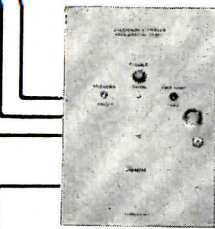

AREA-CONTROL PANEL



DISTRIBUTION PANEL

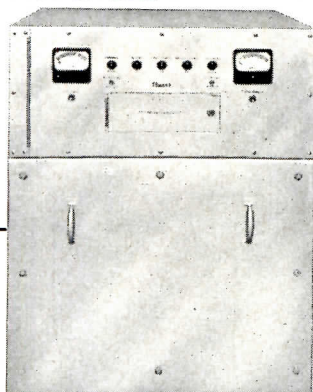

CONTROL CONSOLE

THE STANDARD ELECTRIC TIME CO.

Send for Publication # 243

81 Logan St., Springfield 2, Mass.

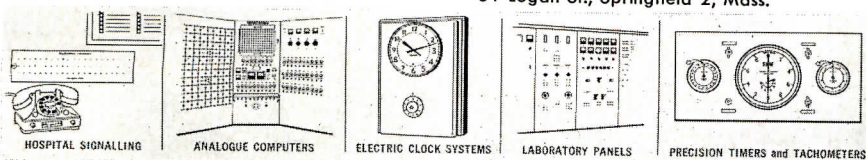

in varying amounts determined by demand.

The system has already been tested thoroughly at the Lennox engineering laboratories. Further research in the test school is intended to iron out on-the-spot problems and to determine just what the system will mean to students and teachers. One of the two classrooms is designed for second grade students and the other for high school students, so that a cross section of student reactions can be obtained. The system will be exposed to extremely difficult conditions, because the school was deliberately orientated to produce real problems in heating and ventilation. It will be exposed not only to excessive heat from the sun but also to severe cold temperatures and high wind velocities.

The manufacturers of the system expect that successful completion of the testing will make possible comfortable classroom temperatures regardless of the weather outdoors and the number of students in the room — with a savings in installation costs and upkeep.

CONCRETE ROOF POURED WITHOUT CONVENTIONAL FORMS

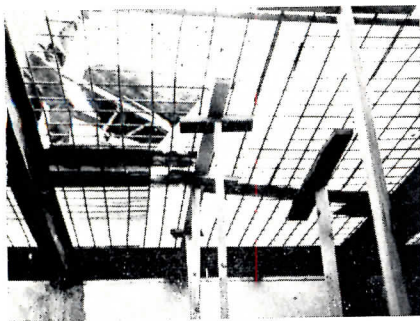

Polyethylene film laid over reinforcing rods replaced conventional forms in a concrete roof installation recently completed by a builder in Twisp, Washington. The contractor, R. D. Schrier, made use of I-beams placed on 8 ft. centers to support 3/8 in. reinforcing rods laid at 6 in. intervals transverse and parallel to the beams, and tied to form a mesh. The concrete was poured directly onto six mil polyethylene film laid across the rods and covered with standard reinforcing mesh. The combination of rods, film and mesh, assisted by temporary bracing which was removed when the concrete had set, proved able to withstand the weight of the concrete without the use of more expensive forms.

(More Roundup on page 246)

When Power Fails

RELY ON

EMERGENCY LIGHTING

by *Standard*
Always on Guard

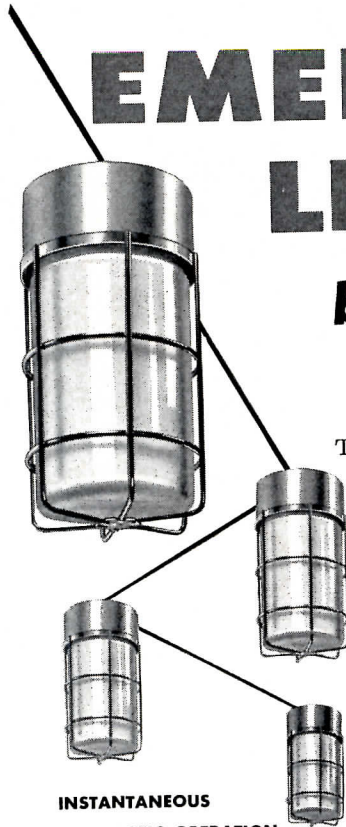

The only Emergency Lighting System that protects itself 100% against failure. Listed by Underwriters' Laboratories, Inc. Exceeds requirements of the National Electrical Code. Get all the details now. Send for Publication #243.

Handsome fixtures with concealed wiring are built-in — just like the fire alarm and sprinkler systems.

- INSTANTANEOUS
- AUTOMATIC OPERATION
- AUTOMATIC RECOVERY
- ELECTRICALLY SUPERVISED
- 100% DEPENDABLE

for:

- HOSPITALS
- SCHOOLS
- PUBLIC AUDITORIUMS
- BANKS - STORES
- RESTAURANTS
- OFFICE BUILDINGS

Send for
Publication #243

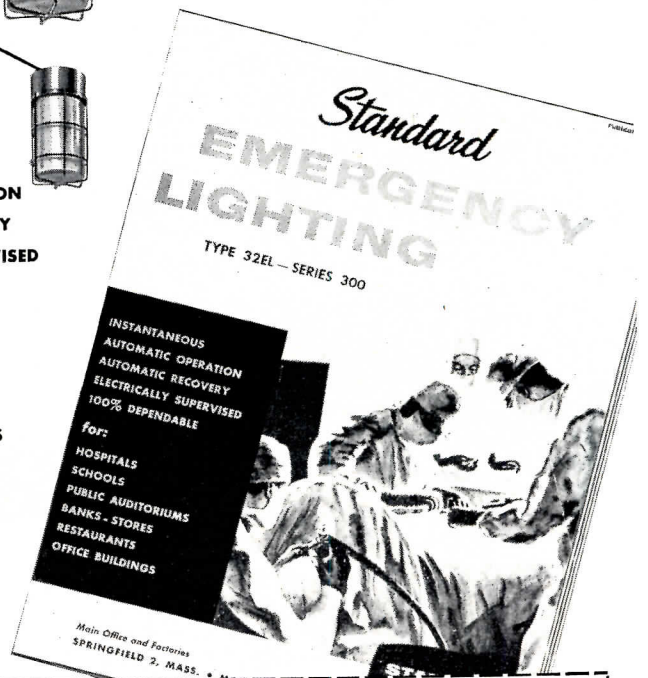

The **STANDARD** ELECTRIC TIME CO.

81 Logan St., Springfield 2, Mass.

Please send me Publication #243

Name..... Title.....
 Company.....
 Street.....
 City..... State.....

VISQUEEN film surpasses rigid FHA test requirements

I.M.

ESTABLISHED 1880



EARLY ADDRESS
U.S.T.E.C.O., HOBOKEN, N.J.
TELEPHONE
HOBOKEN 3-3166

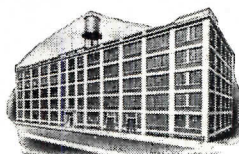

NEW YORK
BOSTON
PHILADELPHIA
HOBOKEN
MEMPHIS
PROVIDENCE
DALLAS
CHICAGO
LOS ANGELES
DENVER
CANADA
WILMINGTON, DEL.
SAN ANGELO, TEXAS

UNITED STATES TESTING COMPANY

INCORPORATED

GENERAL OFFICES 1415 PARK AVENUE
HOBOKEN, N.J.

April 27, 1956

The Visking Corporation
P. O. Box 1410
Terre Haute, Indiana

Gentlemen:

Re: Test No. E-13155 dated April 27, 1956 on
Visqueen (polyethylene) .004" and .006"
Film by Federal Housing Administration
Test Procedure

The attached report completes all of the tests required
by the Federal Housing Administration Bulletin dated
September 1, 1955, entitled: "Test Procedure for Vapor
Barrier Material under Concrete Slab and for Ground Cover
in Crawl Spaces."

Visqueen met all of the requirements of the above mentioned
test procedure by a considerable margin, as indicated in the
combined report.

If you desire further information, our laboratories will be
happy to serve you.

Very truly yours,

UNITED STATES TESTING COMPANY, INC.

R. F. Gerow
R. F. Gerow

VISQUEEN film has successfully passed the test requirements for Vapor Barrier Material established by the Federal Housing Administration, as evidenced by the letter of the United States Testing Company, Inc.

Use VISQUEEN film with utmost confidence that it will do everything a vapor barrier should.

Protect the homes you design or build from moisture damage *for the life of the building.*

Save up to 50% on your vapor barrier costs because VISQUEEN film is so inexpensive to install.

Many other uses for VISQUEEN film on every job. Use it again and again for temporary closures, equipment covers, all-weather protection for lumber and materials stored outside.

Only VISQUEEN film offers a width for every job. Check this list! 3', 4', 6', 8', 10½', 12', 14', 16½', 20', 24', 26', 28', 32'.

Important! VISQUEEN film is all polyethylene, but not all polyethylene is VISQUEEN. Only VISQUEEN, produced by process of U.S. Patents No. 2461975 and 2632206, has the benefit of research and resources of The Visking Corporation.

SLAB FLOORS—Cut your labor costs up to 50%, get permanent protection against moisture with tough, seamless VISQUEEN film under concrete slabs.

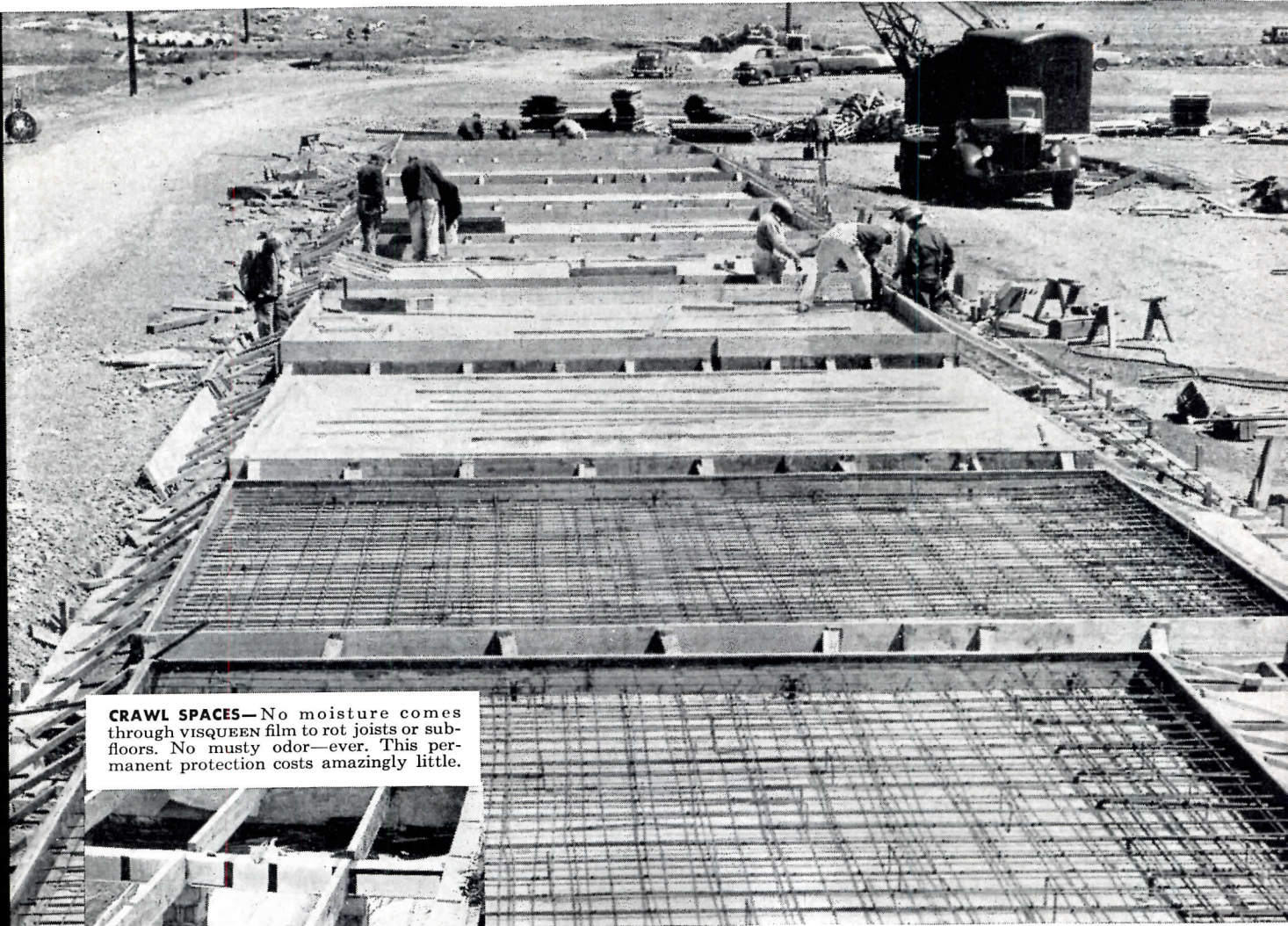

CRAWL SPACES—No moisture comes through VISQUEEN film to rot joists or sub-floors. No musty odor—ever. This permanent protection costs amazingly little.

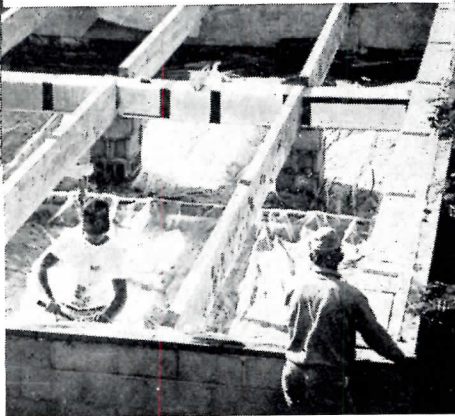

WALLS—VISQUEEN film on the warm side of the walls prevents condensation within studwall, cracking or peeling of paint, decay of wood.



Look for this name on the selvage



THE VISKING CORPORATION

World's largest producers of polyethylene sheeting and tubing

Plastics Division, Box 1410, Terre Haute, Indiana

IN CANADA: VISKING LIMITED, LINDSAY, ONTARIO

IN ENGLAND: BRITISH VISQUEEN LIMITED, STEVENAGE

TECHNICAL ROUNDUP

(Continued from page 230)

LARGEST PLASTIC SKYLIGHTS PREASSEMBLED FOR NEW PLANT

The new Owens-Corning Fiberglas plant nearing completion in Barrington, N. J. will be daylighted by 126 custom-made skylights of Fiberglas reinforced plastic, measuring 9 by 20 ft each. According to the Marco Company of East Orange, N. J., fabricator of the units, these are the largest prefabricated, preassembled Fiberglas plastic skylights yet to be installed.

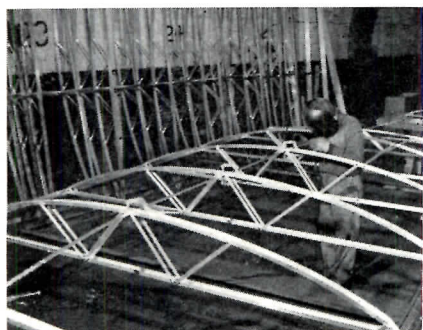

After the aluminum frame was welded, plastic sheets, pre-molded to the proper curvature, were placed on the frame. A bead of viscous mastic, compatible with the basic resin, was stripped along the edge of each sheet. Upon bolting, the sheets were in effect welded together plastically. An extruded aluminum retaining angle covers the edges of the plastic sheets. The skylights were installed atop roof curbs provided by the contractor. (More Roundup on page 250)

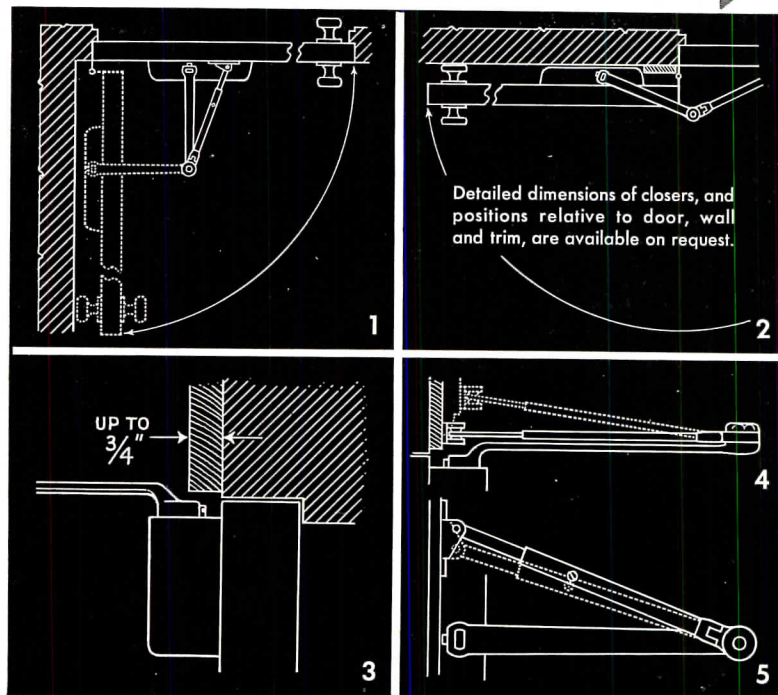
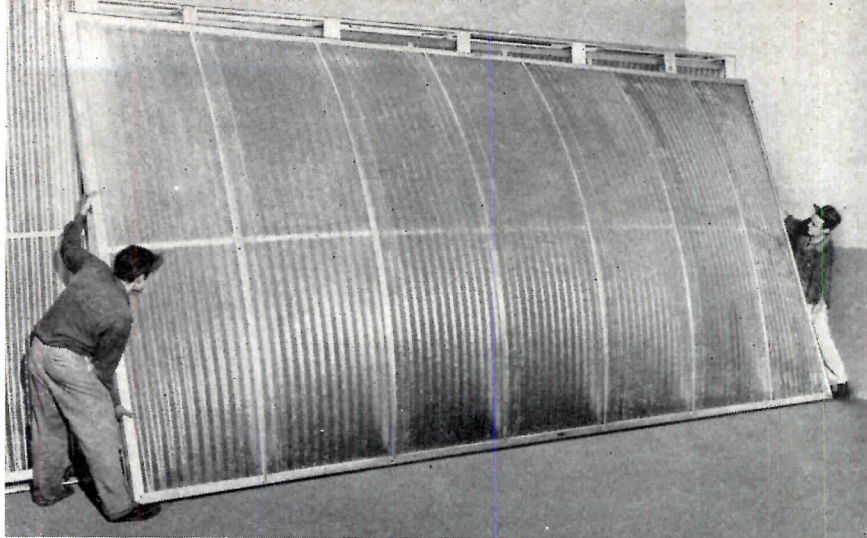
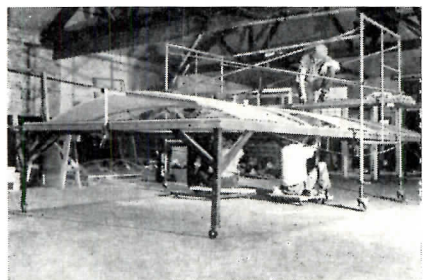

APPLICATION DETAILS

for the New LCN "Smoother" Exposed Door Closer
Shown on Opposite Page

As Demonstrated in Drawings Above:

1. The LCN "Smoother" takes less space than most doorknobs between door and wall.
2. Degree of door opening possible depends mostly on type of trim and size of butt used.
3. Arm of LCN "Smoother" is curved to avoid conflict with almost any conventional trim.
4. Joints in arm and shoe make it easy to vary the height of shoe as needed for beveled trim.
5. Power of closer is increased or decreased by simply reversing position of shoe.

For Other Types of LCN Door Closers, Send for Complete Catalog—No Obligation—or see Sweet's, Sec. 18e/La

LCN CLOSERS, INC., PRINCETON, ILLINOIS

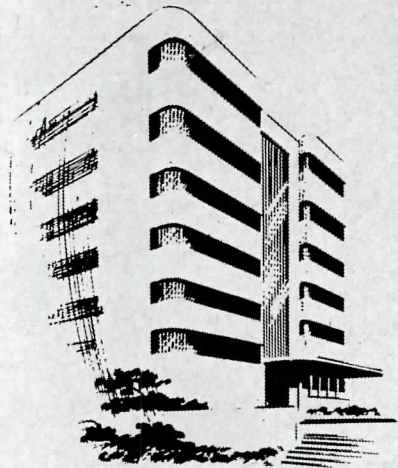
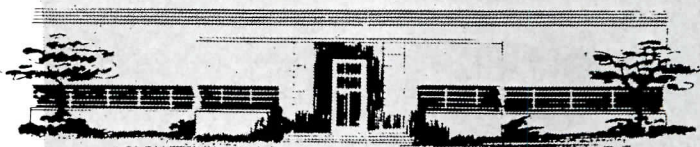
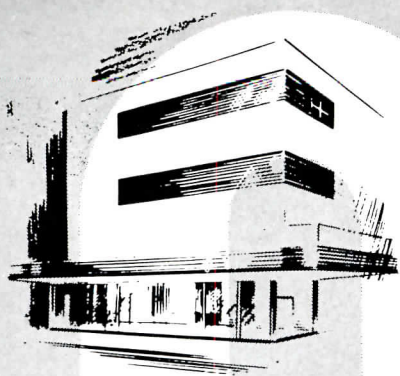

Three good reasons why **MONARCH** Panic Exit Devices are specified!

1. ENGINEERED FOR LASTING PERFORMANCE

—Produced in Brass or Bronze, these devices are built to withstand the most rugged use. Parts are few and simple, yet extremely heavy. Monarch Devices conform fully to all Federal Specifications.

2. TIME AND LABOR SAVED ON INSTALLATION

—The Monarch Device of your choice, either Rim, Mortise or Vertical Rod type is drilled to template with drill fixtures . . . never any other way. New templates are clear and easy to read, making it possible for better installations at a minimum of time . . . fewer callbacks for adjustments, too!

3. SERVICE—Great care and efficiency is exercised in the assembly and modern packaging of Monarch Panic Exit Devices. All orders are processed promptly and there is no waiting for delivery.

Specify MONARCH on your next project

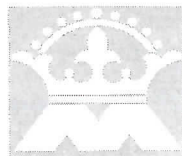

MONARCH
HARDWARE & MANUFACTURING CO.
P. O. BOX 43 • LaGRANGE, KY.

See **MONARCH**



Specifications in
SWEET'S FILE

or write for illustrated catalog.

MONARCH HARDWARE & MANUFACTURING CO.

P. O. Box 43 • LaGrange, Kentucky

- Please send complete catalog of Panic Exit Devices.
 Please have your representative call.

Name _____

Firm _____

Address _____

City _____ Zone _____ State _____

MAXIMLITE SCHOOLS

(Continued from page 220)

Heating the Maximlite Schools

"Our heating systems for the Maximlite schools," added Mr. Shelton, "have been designed as another feature. Basically they provide heating in such a way as to guard 100% against any heat loss from a central heating room . . . for the simple reason there is no central heating room. Heat is generated, controlled from the individual classrooms.

"Rooms are heated by warm air or gas from either gas or oil fired heaters located in the metal bookshelves. Distribution is through a perimeter duct system. Usually our heaters are capable of from 65,000 to 85,000 BTU's. Naturally, the oil fired heaters are placed in fire resistant closets around 4 feet square.

"Saving from our heating alone is high. Figures show that some of the schools get L.P. gas for as low as \$0.10 per gallon and this is used in a 46,000 square foot High School. A six-classroom

school at Linden, Pennsylvania, with an area of 7,800 square feet was adequately heated for a cost of \$280.00 over a five month period . . . and temperatures went as low as — 6° F!

"Equally important is the fact that teachers can set temperatures to suit the classroom condition at any time during the day . . . and the continuous grill around the room gives each classroom 100% even flow of air. All shelving, of course, has asbestos edges. The Maximlite heating system pays for itself in 10 years . . . through the elimination of monies which would ordinarily be spent for a central furnace and a 2nd Class Engineer.

Architectural Associations

"Since we started in 1951 we have never had to re-design a building and have used glass blocks in all our schools. We have never had a contractor go broke on one of our jobs. We get 95% of awarded bids . . . and, in addition, we have 25 firms of architects with over 105 offices across the United States associated with us.

Fabrication

"The Maximlite school is not a pre-fabricated building," explained Mr. Shelton, "how could it be when we use glass block walls. There is standardization but not a standard set of plans. We design every shape building in the world. We effect savings, not for ourselves, but for the consumer through 'mass-production' of such items as shelving, warm air ducts, wainscoting and heat design. Also some of our window units are handled the same way. We do not, however, have a single source of supply. The masonry blocks we use, for example, come from different suppliers in different parts of the country depending upon building location. Glass block usage runs about 58 carloads a year.

"Before we bid on a job we make a completely detailed analysis of the work . . . get down to actual on-the-spot material costs, masonry costs, glass blocks, structural steel, labor costs, concrete and so forth. We do not guess (as many do) on a single phase of the construction. In our new Detroit school, for example, we know we will use exactly 56,000 glass blocks!"

Psychological Advantages

The effect of the Maximlite school design is, perhaps, best measured in the reactions of the teachers and students who occupy the buildings. "Children,"

(Continued on page 322)

Prevent Leaks . . . in curtain walls

Tremco research, aided by representatives of leading glass manufacturers, has developed new glazing and sealing techniques for curtain wall construction.

You'll find these new specifications important to insure leak-free installations. Ask your Tremco Man for a copy of "NEW PRODUCTS AND METHODS FOR NEW GLAZING AND SEALING PROBLEMS," or write: The Tremco Manufacturing Company, 8701 Kinsman Road, Cleveland 4, Ohio, or The Tremco Manufacturing Company (Canada) Limited, Leaside, Toronto, Ontario.

"When you specify a Tremco product — you specify a Tremco service!"

TREMCO
PRODUCTS AND METHODS FOR BUILDING MAINTENANCE & CONSTRUCTION

NEW PRODUCTS AND METHODS for NEW glazing and sealing problems...
TREMCO RESEARCH

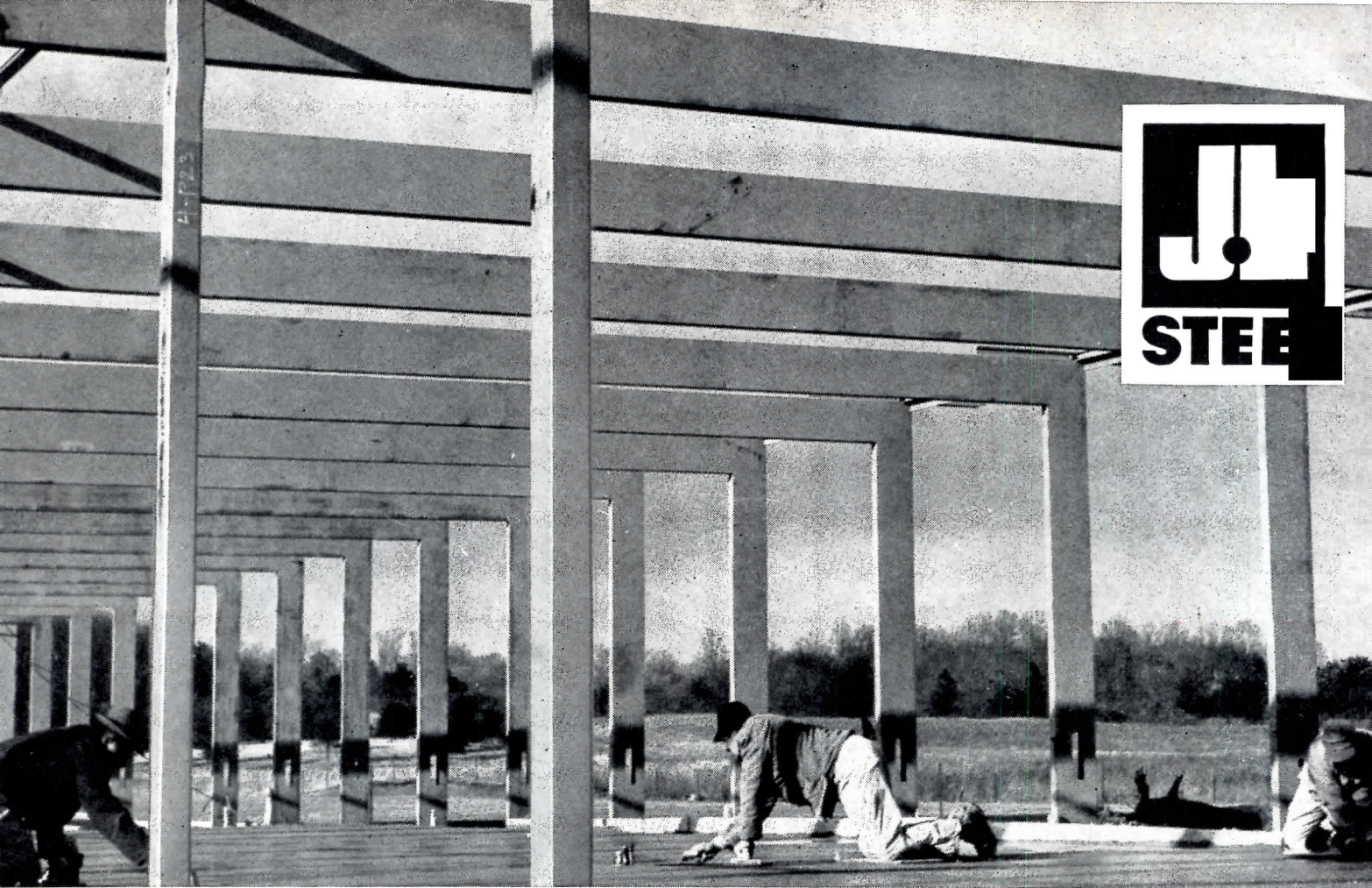

RIGID STEEL BENTS FORM BASIC FRAME OF WHEATLEY SCHOOL, EAST WILLISTON, LONG ISLAND

Boxed and Exposed J&L JUNIOR CHANNELS give classrooms clean, fresh appearance

Architect W. Frank Bower, Jr., of La Pierre, Litchfield & Partners, New York, has employed 130 tons of Junior Channels in the new two million dollar Wheatley School (East Williston, Long Island Junior-Senior High School). The 12", 10.6# Junior Channels are boxed to make rigid bents forming the basic frame of the classroom buildings.

The bents were fabricated in two sections by De Voe Iron Works, Inc. of Long Island City, then trucked to the job. Erection went fast. Mr. Stephen J. De Voe, Jr. reported that it required only five hours to erect the 56 bents in one 232' x 71'-4" building. Mr. Bower summed up the advantages of

using J&L Junior Channels in the school's unique design by saying:

"The exposed structural steel bents or rigid frames are the basic frame of the building. This was done to take advantage of insulating cement and wood fiber structural plank which has excellent acoustical properties. In addition we avoid the use of hung ceilings. As a result we estimate savings of \$40,000 to \$50,000 on this \$2,000,000 building.

"This type of construction eliminates the confined air space between roof and hung ceiling which, unless mechanically ventilated, stores hot air to reflect heat on the classrooms in the warmer months. The rigid

frames give a cleaner, fresher look than alternate materials. We prefer them as being more interesting than the usual flat hung ceiling. They also give us a chance to introduce more color into the classrooms."

If you're designing light occupancy buildings, ask us for complete information about J&L Junior Channels. Take advantage of the strength of these light weight hot rolled sections, and their adaptability to a wide range of architectural design.

Jones & Laughlin
STEEL CORPORATION · PITTSBURGH

Artist's rendering of the Wheatley School

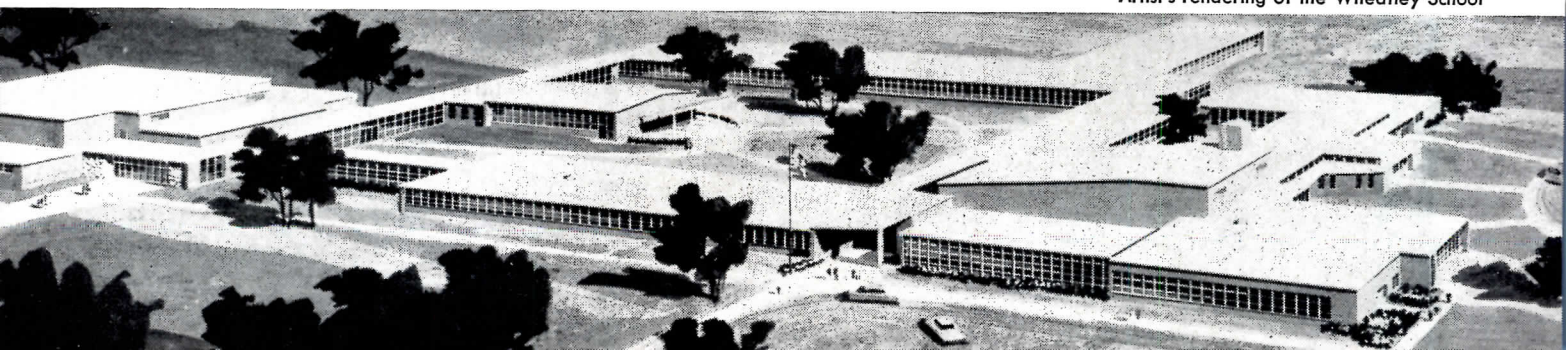

MAXIMLITE SCHOOLS

(Continued from page 320)

stated Sister Regina Marie, St. Joseph's Parochial School, Fayetteville, Arkansas, "are naturally fidgety . . . but in these pleasant classrooms the lack of actual 'nervousness' in the children is noticeable, which we attribute to the pleasant, well-lighted surroundings."

Teachers in the Root Elementary School, Fayetteville, Arkansas, are equally impressed with the school. Mrs. Roma Ambrose, Teaching Principal

stated, "We have 204 students in our six grades . . . and both they and the teachers feel the atmosphere of the classrooms actually increases the application of the students for their work."

"What we have always had in mind in this respect," reaffirmed Mr. Shelton, "and the reason we concentrate on classrooms . . . was the soothing atmosphere the students would get from the rooms. For example, we decorate only in pastels . . . and that in juxtaposition to the light factor. Usually we have green, blue or gray on the south, and on

the north yellow, cream or buff . . . each of which improve the lighting of the rooms.

Final Considerations

"We build our schools around the classroom," concluded Mr. Shelton, "and do not fit the classrooms into a predetermined building. Each of our classrooms is 1/6th of a 360° angle giving us six to a circle . . . a cost savings design because a 5 or 7 room design would automatically give an unusable cut on everything laid out.

"In addition, with 36' of wall space in the ordinary classroom one can do only so much . . . but with 45' as in ours, one can get almost twice as many benefits . . . where (1) light (2) ventilation and (3) acoustics are concerned. This is achieved through the basic glass block design. In the Root School, for example, we have four courses of 12" x 12" glass blocks; then an additional course below the pane glass windows of 8" blocks. We have, in addition, six Lite-craft tinted fixtures at 500 watts per bulb. All told, in the Root school we have 3,000 12" x 12" and 12,000 8" glass blocks.

"All Maximlite buildings are generally one-story. The perimeter is supported by steel columns. Naturally, our interior walls are load-bearing lightweight concrete block and glazed wainscoting. We have no basements in our buildings. We have reinforced concrete outside to sill height and glass blocks to the roof. Each room is furnished a continuous vision strip with operable sash between the glass blocks. Our floors are reinforced concrete slabs and generally have an asphalt or vinyl tile finish. Roofing varies from wood, steel decking or open-web steel joists and finished with 20-year-bonded built-up roofing. Ceilings are fiberboard.

The Architect

Mr. T. Ewing Shelton has offices located in the First National Bank Building, Fayetteville, Arkansas. He has been practising architecture for the past 30 years and was licensed by the State of Arkansas in 1936.

Main clusters of the Maximlite schools are to be found in central United States . . . Kansas, Missouri, Oklahoma and Arkansas . . . although schools have been erected in Lisbon Falls, Maine, as far west as Carson City, Nevada and, internationally, Alberta, Canada.

"In design we have three criteria we follow closely," commented Mr. Shelton, "first, the structure, secondly, economy and lastly, looks.

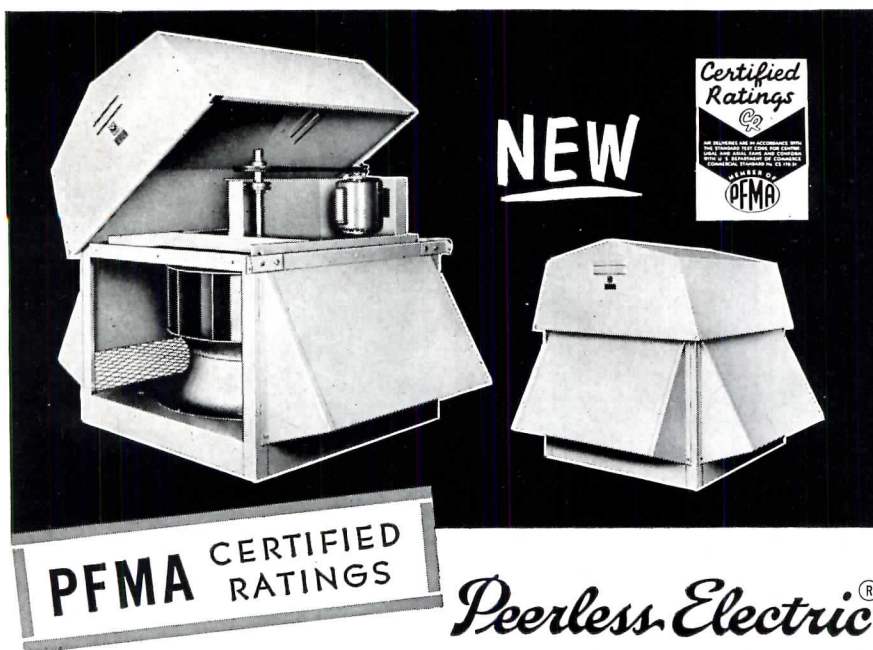

Peerless Electric® Centrifugal Roof Ventilator

DEVELOPED AND MANUFACTURED WITH
APPLIED CENTRIFUGAL BLOWER PRINCIPLES

QUIET! . . . Matching wheel cone accurately fits venturi inlet for quieter, smoother air movement. Ideal for hospitals, churches, auditoriums and schools.

STURDY! . . . All welded construction. Material 16 ga. or over. Built for life of building.

PERFORMANCE! . . . Each unit air-tested, and rated to assure certified ratings. Excellent efficiencies. Detailed performance data in Bulletin SDA-220.

ADAPTABILITY! . . . Fits standard curb sizes. Lower h.p. for quieter operation. Higher h.p. for commercial and industrial applications.

Write Today For Bulletin SDA-220!

Charter Member of the Air Moving and Conditioning Association, Inc.

FAN AND BLOWER DIVISION



THE Peerless Electric® COMPANY

1448 W. MARKET ST. • WARREN, OHIO

FANS • BLOWERS • MOTORS • ELECTRONIC EQUIPMENT

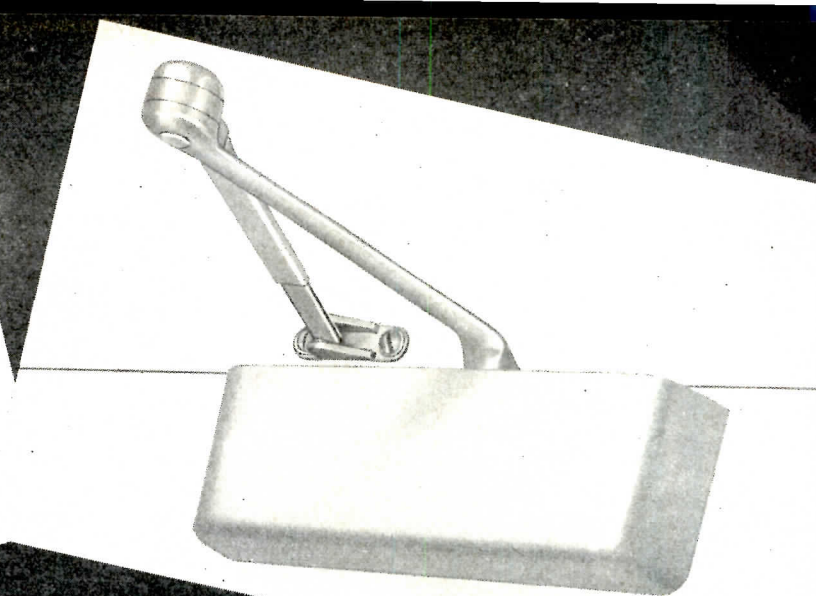
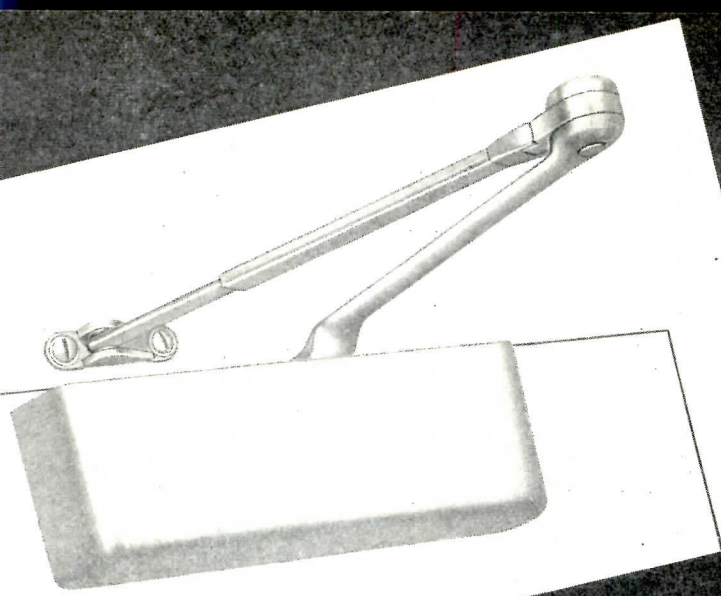

Announcing The Brand New "Smoothee" Door Closer by *LCN*

Officially Nos. 4002, 4003 and 4004

An Exposed Type Closer That's Actually Good Looking
with Clean Lines and Practical, New Features

We call it the "Smoothee" because that's what it really is—smooth to look at and smooth in mechanical performance. And it has some new features that almost anyone would agree are "pretty smooth."

It's compact, fits closely against the door, can be painted to blend with door and trim.

Trim permitting, it allows full 180 degree opening, as it projects from the door less than a standard doorknob.

It applies equally well to wood or metal interior doors, and calls for no more skill to install on the job than the ordinary exposed closer.

Its sleek, strong arm has several features welcome to users and installers: (1) a jointed forearm that permits placing the shoe an inch or more higher than normal to avoid a trim bevel; (2) a surface-applied shoe with off-center rod connection providing increase of power by simply reversing the shoe; (3) a new universal joint between rod and shoe to prevent binding; and (4) a flat steel rod slipping into the forearm with an almost invisible connection.

Altogether, this new LCN "Smoothee" fills a big need in the building business. For many, many interior doors it offers fine control equipment at moderate cost.

Additional Details on Opposite Page

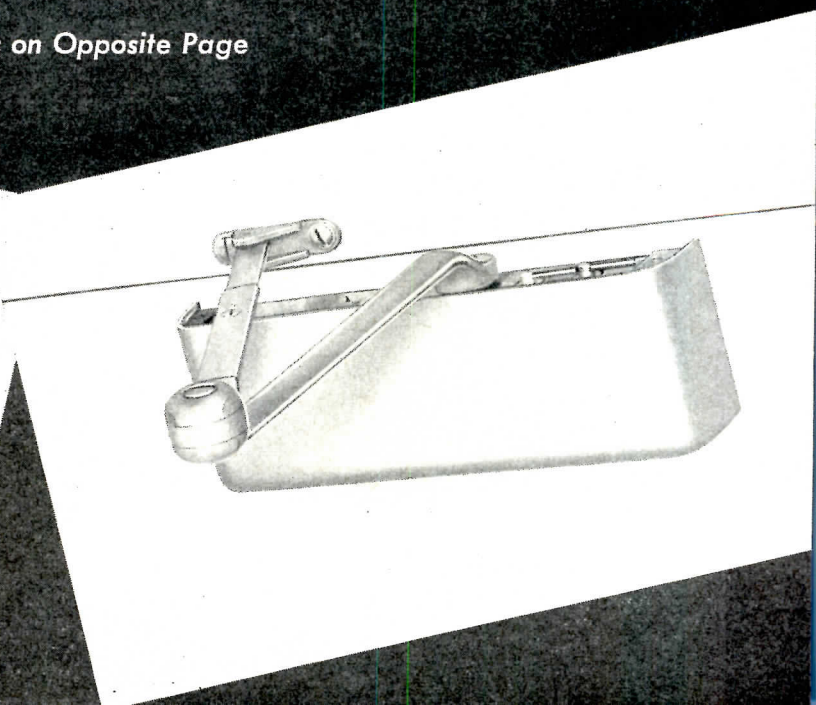
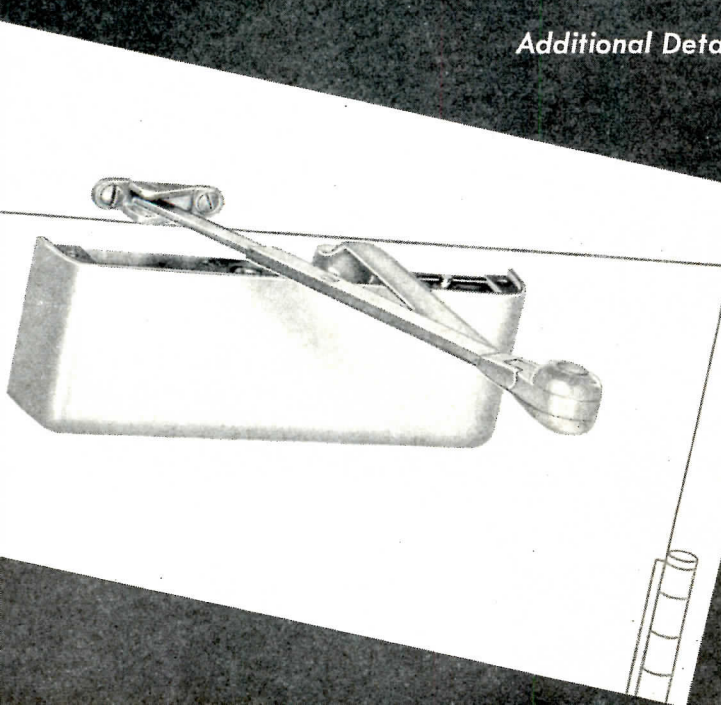



Butternut, background for elegance... a spirited graciousness

■ Jim Brown, whose name has graced many of the superb photographic illustrations of the day, brings the photographer's discerning eye to the mellow, ageless character of pale, lustrous, tan Butternut veneer by Stem in this self-portrait. "The feeling and texture of a panel of rare wood veneer, like that in the illustration, has no equal as a background for bringing out elegance." The architect, like the photographer, can find in veneer paneling all the excitement and charm that are reflected from the depths of this mellow panel of Butternut. Through the catalytic artistry of the architect, rare wood paneling and graceful living strike up a happy match. Wherever a background of fine wood is used, its noble

presence is felt by all, welding substance and spirit into exciting unity. When rare woods from the forests of the world are used, there is a spirited graciousness—a strength and beauty that dwell in every ripple of its meticulously finished grain. And yet, beautiful wood is the essence of peace; it brings serenity to a room in a way that is all its own. Now, Stem brings you, through the magic of modern factory methods, all the nobility, splendor and lifetime permanence of the finest veneer that tradition knows. And you can afford to be generous with this wood, for the cost is low.

Chester B. Stem, Incorporated
185 Grant Line Road New Albany, Indiana
New York — Chicago — Dallas — Los Angeles

RARE WOODS
FROM STEM



INCREASED PRODUCTION

THE GEORGIA MARBLE COMPANY—the most efficient stone and marble producer in the U. S. A.—is now in full charge of production in the ALBERENE STONE quarries and mills at Schuyler, Va. Greatly stepped-up output now permits us to say, "Let's talk immediate deliveries!"

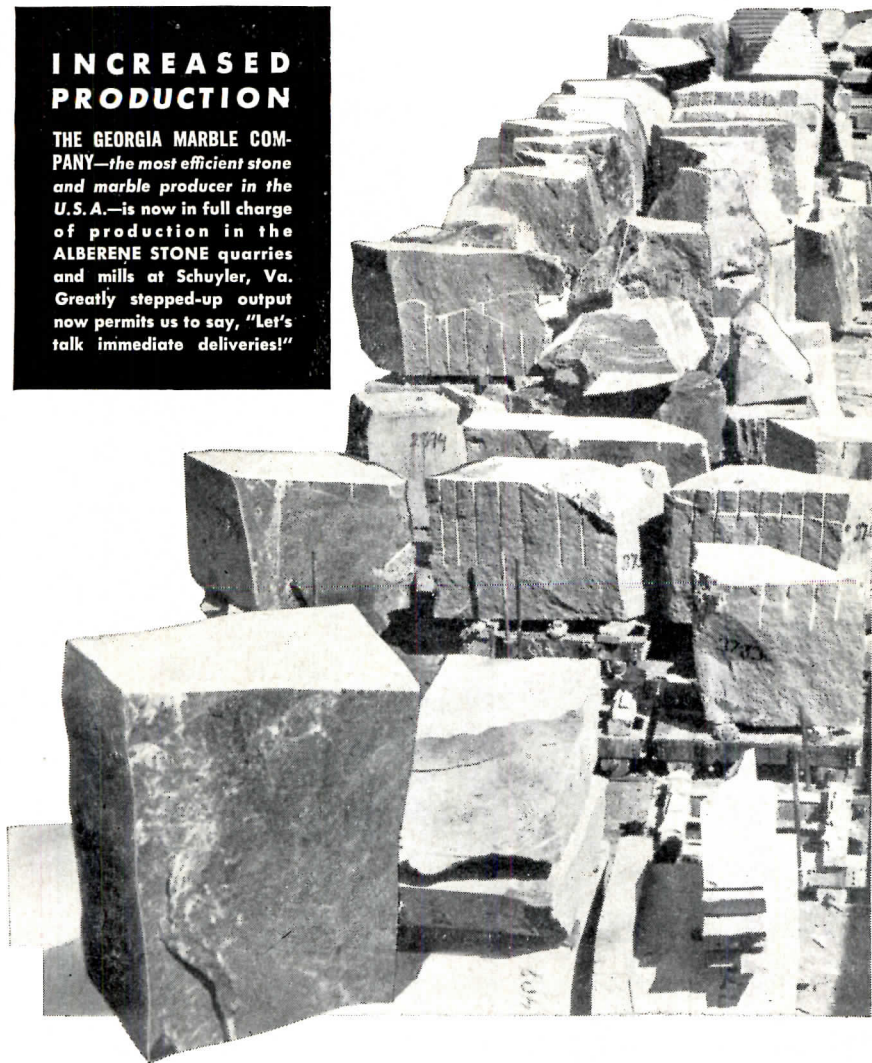

Immediate Deliveries!

Alberene Stone can be shipped normally in 90 days—or even sooner to meet very special circumstances. We can schedule our deliveries to meet all reasonable requirements of contractors and laboratory equipment manufacturers.

Further, the supply of Alberene Stone is inexhaustible. New veins are constantly being located in company owned quarries in Albermarle and Nelson Counties, Va.

Alberene Stone is the only natural silicate stone with the surface that goes all the way thru. It can be cut, drilled, tongue-and-grooved, refinished and reused almost indefinitely — while providing the best obtainable chemical resistance!

For information and technical assistance, address: Alberene Stone Corporation, 419 Fourth Avenue, New York 16, N. Y.

ALBERENE STONE

provides **LOW ABSORBENCY** protection

TECHNICAL ROUNDUP

Welding Design Competition

Five thousand dollars in cash awards to students, as well as scholarship funds for their schools, are being offered by the Lincoln Arc Welding Foundation of Cleveland, Ohio in the tenth of its series of design competitions. Separate competitions in mechanical and structural design are offered, and any resident college engineering undergraduate may compete by entering a design for a machine, machine part, structure, or structural part which makes a significant use of arc welding. Rules booklets are available from the James F. Lincoln Arc Welding Foundation, Cleveland 17, Ohio.

GLASS BLOCK CONTROLS LIGHT, TEMPERATURE

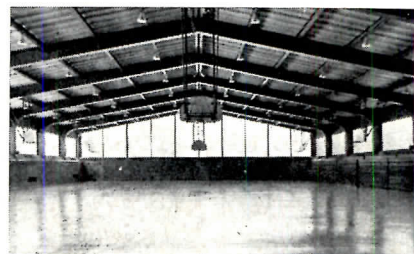

In designing a large gymnasium-natorium for the Angel Guardian Orphanage in Chicago, architects Gaul and Voosen approached the problems of effective light, temperature and condensation control with an extensive use of glass block. Twelve inch square glass blocks, mortar set with aluminum channels at top and bottom, form panels that cover almost a third of the total wall area. This large glass surface allows maximum use of natural light to provide glare-free illumination, making supplementary lighting seldom necessary during daytime use and reducing lighting costs. The heat loss usually associated with an extensive use of glass is minimized by the insulating properties of the hollow-cored block, which are said to equal those of an eight inch masonry wall. It was found that desired temperatures could be maintained in the gymnasium area by eight heater-ventilator units on the north and south walls and a strip heater on the west wall, without placing an excessive load on the existing heating plant. The insulating qualities of the glass block are also said to have virtually eliminated troublesome surface condensation in the swimming pool area.

(More Roundup on page 254)

ANEMOSTAT *Announces . . .*

ALL-AIR

CONSTANT VOLUME

**HIGH
VELOCITY
UNITS**

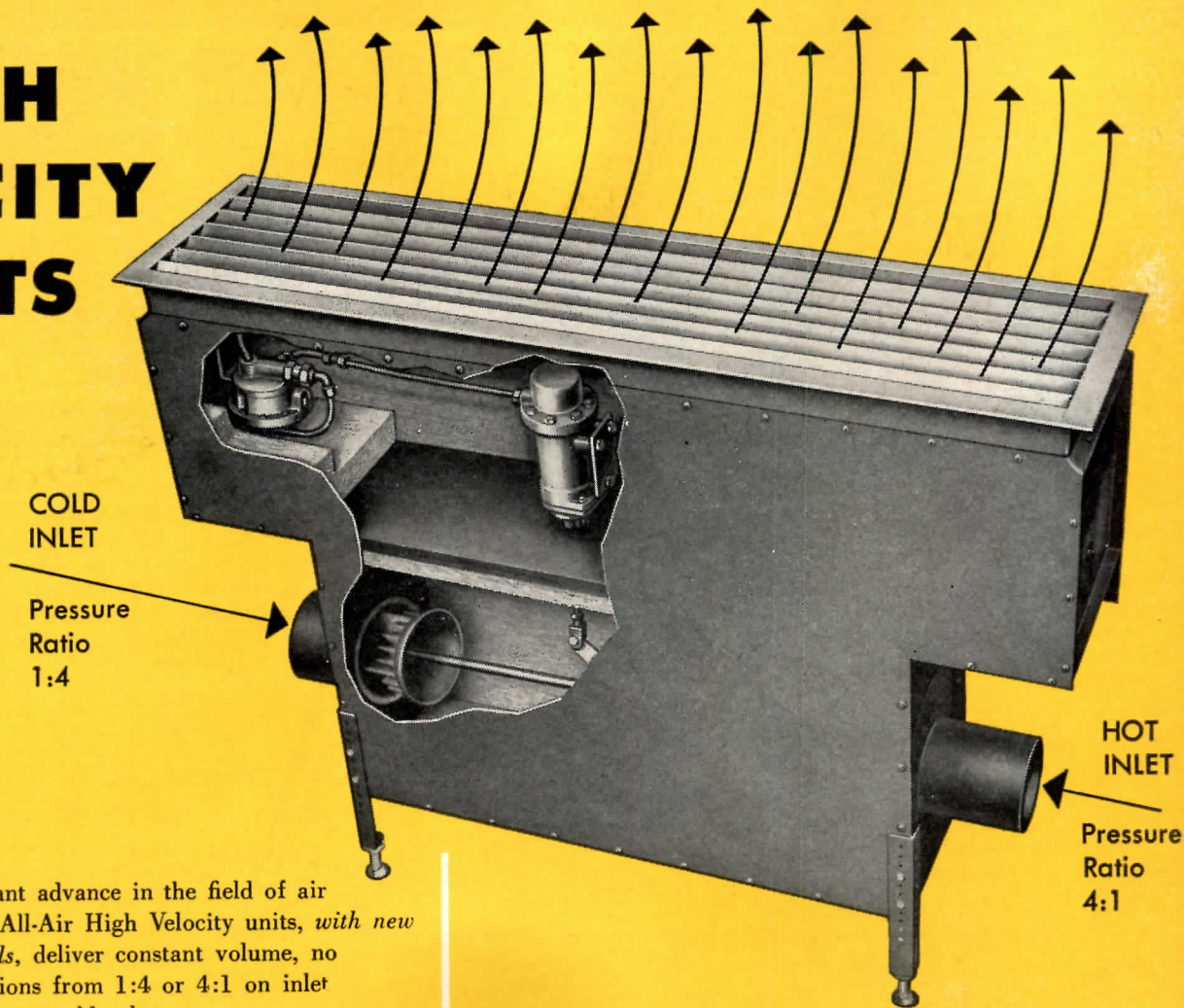

Here is a vitally important advance in the field of air distribution. Anemostat All-Air High Velocity units, *with new simple automatic controls*, deliver constant volume, no matter what the fluctuations from 1:4 or 4:1 on inlet pressures of either the hot or cold valve.

Each unit is a single package including the controls and integral thermostats if required. There is complete accessibility of all controls through removable diffusers. No access panels are required. Capacities of **CONSTANT VOLUME** units can be pre-set at the factory.

These Anemostat CONSTANT VOLUME units

- Assure scientific draft-free distribution of air.
- Are available in 100% induction units.
- Include Anemostat die-cast metal rocket-socket valves. More than 50,000 of these valves are in service, and not a single one has needed maintenance.
- Operate on standard 15 lb positive acting compressed air systems.

See your nearby Anemostat representative for complete details on these revolutionary Anemostat All-Air **CONSTANT VOLUME** High Velocity units.

Anemostat: The Pioneer of All-Air High Velocity Systems

ANEMOSTAT®

DRAFTLESS *Aspirating* AIR DIFFUSERS

ANEMOSTAT CORPORATION OF AMERICA

10 EAST 39TH STREET, NEW YORK 16, N. Y.

Representatives in Principal Cities

Stretch Budgets for Church with Janitrol

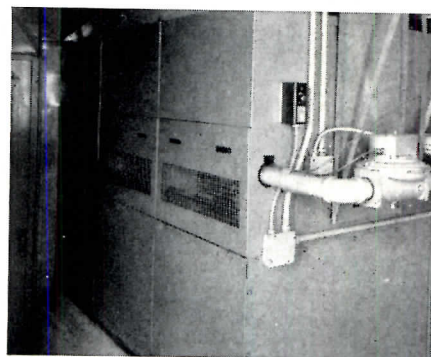
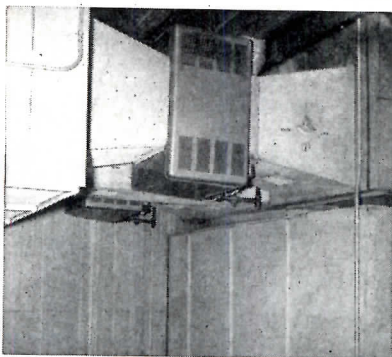

Heating and cooling for this church is handled by three Janitrol Duct Furnaces, combined with a 60-ton cooling system. Janitrol Duct Furnaces are especially designed for use in combination systems . . . save money by using same blowers and ducts as cooling system.

Unusual quietness in operation wins praise from pastor and congregation for this Janitrol gas-fired central system. Six Janitrol BDC Heavy Duty Gas-Fired Heaters provide 1½ million Btu/hr. input. System is compact, easily accessible, and economical.

When you are specifying heating or cooling equipment for needs peculiar to churches, it will pay you to know these facts.

Janitrol's complete line of equipment for new construction and modernization includes units for virtually every church heating and cooling requirement . . . with unusual flexibility of installation. Whether the job calls for a compact central system, multiple

winter conditioners adaptable for summer cooling

. . . with installation of Janitrol's new air-cooled cooling system that uses no water, eliminates water service and maintenance costs. May be installed concurrently with winter conditioner, or any time later, without additional ductwork.

Building and Modernization Heating and Air Conditioning

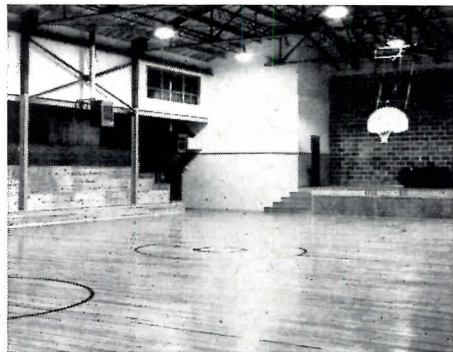
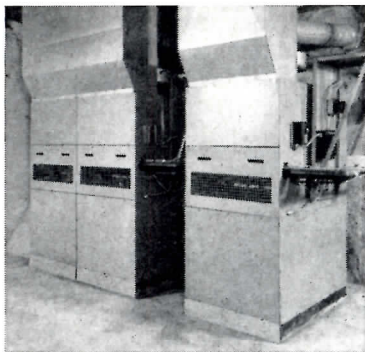

Separate central systems to heat upstairs and downstairs rooms were installed in this church modernization job. The ultimate in a compact, efficient, automatic installation was achieved with Janitrol gas heating equipment.

If the old heating system is in good shape, conversion to automatic gas heat with Janitrol High Capacity Gas Conversion Burners is often the best answer. They're designed for large capacity systems. This installation uses four Janitrol SC-05 burners.

Janitrol gas unit heaters work independently of central system to heat large gymnasium... provide fast, low-cost heating and temperature control required by the varying activities program. Janitrol unit heaters are designed for dual-fuel operation, save floor space, insure low maintenance costs.

units, or a combination of both, Janitrol brings you welcome design freedom!

Purchase costs are well in line, too. And, superbly designed, solidly built Janitrol equipment minimizes installation costs. You can enhance your reputation with Janitrol quality, even on modest budget jobs.

Of course, you want to insure your client's satisfaction for the years to come

as well. And thousands of Janitrol installations testify that Janitrol quality means top-level comfort, with important savings in operating and upkeep costs.

Look into Janitrol equipment for your next job. Our engineers will gladly work with you in developing complete specifications. Call your Janitrol office, or write Janitrol Division, Columbus 16, Ohio.

Janitrol

JANITROL HEATING & AIR CONDITIONING DIVISION
SURFACE COMBUSTION CORPORATION
COLUMBUS 16, OHIO

IN CANADA: MOFFAT HEATING & AIR CONDITIONING DIVISION
MOFFATS, LTD., TORONTO 15

Also Makers of Surface Industrial Furnaces, Kathabar Humidity Conditioning, Janitrol Residential Heating and Cooling Equipment.

Architects' and Engineers'
information service



Write today for complete A.I.A. files on heating with gas in big buildings of every type, and for Janitrol specifications service. There's no obligation.

**IT PAYS TO HAVE
GOOD
CONNECTIONS**



LANKENAU HOSPITAL
Philadelphia, Pennsylvania
ARCHITECT
Vincent G. Kling
ELECTRICAL CONTRACTOR
Harry F. Ortlip Co.
CONSULTING ENGINEER
A. Ernest D'Ambly
HUBBELL SUPPLIER
Graybar Electric Co.

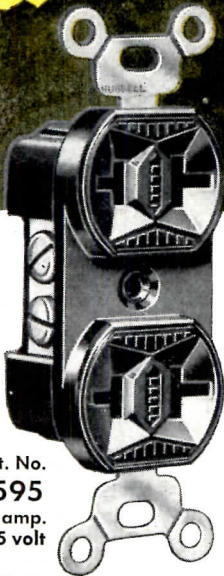
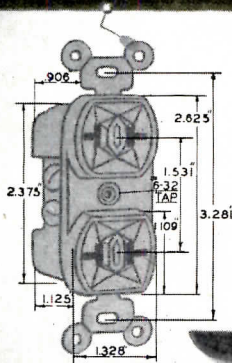

Cat. No.
9595
15 amp.
125 volt

**Pleasing Appearance • Rugged Construction
Functional Convenience • Long-Term Security**

These are the attributes that contributed to an A.I.A. first honor award in hospital architecture for the Lankenau Hospital, above. The same attributes make Hubbell specification-grade wiring devices the choice of architects and consulting engineers throughout the Country.

At left, Hubbell Specification-Grade Duplex Convenience Outlet, one of the many quality devices installed in the hospital... a 100% Hubbell, quality wiring device installation.

**HARVEY
HUBBELL, INC.**

BRIDGEPORT 2, CONNECTICUT

QUALITY WIRING DEVICES

**FACTORY WAREHOUSE
LOCATIONS ASSURE
NATIONWIDE STOCK
AVAILABILITY**

Bridgeport 2, Connecticut
State and Bostwick Streets
Chicago 7, Illinois
37 South Sangamon Street
Los Angeles 12, California
103 North Santa Fe Avenue
San Francisco, California
1675 Hudson Avenue
Dallas 7, Texas
1111 Dragon Street

**CLAY MASONRY FACING
MATERIAL ANNOUNCED**

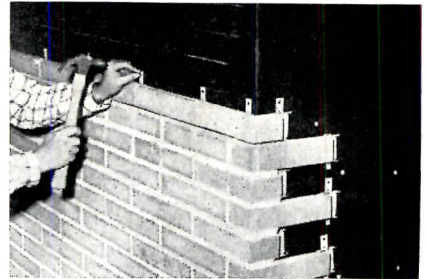

A clay masonry facing material with the fire-resistant, insect-proof, and insulating properties of conventional brick has been announced for test marketing by the Structural Clay Products Research Foundation. SCR Re-nu-veneer is a 3/4 in. thick slab of hard-burned Norman size brick which is installed by placing the unit in a metal clip nailed to the existing wall. The specially designed clip holds each unit independently in place, permitting an equal distribution of weight on the wall. After the units are placed, portland cement mortar applied between the joints is tooled and finished as in conventional brick masonry construction. "L" shaped corner units give a genuine brick appearance on all corners. Aimed principally at the remodeling market, the new product will give existing non-brick exterior and interior walls the appearance, economy and maintenance-free qualities of brick without structural remodeling.

More Technical Studies for BRAB

The Building Research Advisory Board will conduct four additional technical studies for the Federal Housing Administration in 1957. It will:

1. Evaluate experience using small-size sewer pipe.
2. Evaluate the need for grade boards to establish and maintain the grade of pipes in fields of disposal of septic tank effluents.
3. Survey, summarize and evaluate existing experience and opinion with construction, use and maintenance of bituminous surface treatments on flexible pavement basis for residential streets on a nationwide basis.
4. Survey, summarize and evaluate existing experience and opinion within inverted crown streets and alleys for residential developments on a nationwide basis.

(More Roundup on page 258)

Conditioning with HerNel-Cool

Simple chiller installation will add air conditioning to existing unit ventilator system.

Since its founding in 1916, the Emily Griffith Opportunity School in Denver, Colorado, has been a symbol of progressive thinking in education.

That same progressive thinking went into the planning of the school's modern four story addition, built in 1956. All classrooms and administrative offices are equipped with HerNel-Cool units which heat, ventilate and provide natural cooling with outside air. Only the addition of a chiller in the boiler room is needed for complete hot weather air conditioning. When it is wanted, air conditioning can be secured without disruption . . . and without expensive alteration and installation charges.

HOW THE SYSTEM WORKS

HerNel-Cool units provide individual temperature control for each room, automatically. Most of the year they provide heat, ventilation, or natural cooling (with outside air) as the room requires. When a chiller is installed in the boiler room, HerNel-Cool units also function as air conditioners. In hot weather, the units switch automatically to mechanical cooling, with chilled water circulating in the same piping that carries hot water during cold weather. The cost is far less than separate heating and air conditioning systems—both for installation and operation.

Thoroughly tested in hot, humid climates, HerNel-Cool units have exceeded every requirement. The system is flexible, too. Units can be installed now where they are needed most—the system can later be extended whenever you wish.

Would you like more information? We will be glad to send you our new 20 page book, "HerNel-Cool AIR CONDITIONER for Schools". Just write to Herman Nelson Unit Ventilator Products, American Air Filter Company, Inc., Louisville 8, Kentucky.



herman nelson
UNIT VENTILATOR PRODUCTS

AMERICAN
AIR FILTER
COMPANY, INC.

American Air Filter Company, Inc., System of Classroom Cooling, Heating and Ventilating

**Any Fuel
Any Climate**



There is a Herman Nelson Unit Specifically Designed to Give You More Classroom Comfort Per Dollar

Flexibility will always be important to Herman Nelson—for there is no "one best" system to provide for heating, ventilating and cooling classrooms. The health and comfort of pupils and teachers come first. The design, structure and location of each school will indicate the most economical and practical system to achieve that ideal classroom atmosphere.

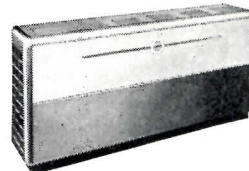

HOT WATER, STEAM
Herman Nelson Unit Ventilators with patented DRAFT|STOP control downdrafts without adding to the classroom heat load, provide ideal classroom climates.



GAS
New UNIVent Gas Fired Unit Ventilator provides all the health and comfort features of the DRAFT|STOP system in a completely self-contained unit.



MILD CLIMATES
AMERVENT built especially for schools in mild climate areas, provides fresh air cooling, heating and ventilating within the nominal cost of heating alone.

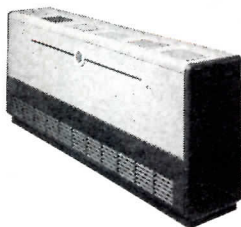

ELECTRIC
New Electric Unit Ventilator in which an electric heating element replaces the hot water or steam coil provides all DRAFT|STOP comfort features.

Will Your Washing Facilities Be Sanitary and Adequate?



School authorities of today, architects and engineers have recognized the importance of sanitary and adequate washroom facilities as exemplified by Bradley Group Washfountains.

FAUCETLESS WASH FIXTURES ELIMINATE CHANCE OF SPREADING INFECTION—SAVE INSTALLATION COSTS AND UPKEEP

These Important Features Banish Washroom Troubles

1. *No faucets to touch*—the central sprayhead serves clean running water to groups—8 to 10 simultaneously... No chance of spreading infections.
2. The big bowl is *self-flushing*—no collection of dirty used water.
3. With *Foot-Control*, water supply is cut off immediately washers leave—conserve water—no waste.
4. Only a bit more water is required for the group of washers than for one at a conventional wash basin.
5. Since *one Bradley* replaces 8 to 10 wash basins, piping connections are reduced over 80 percent—space by 25 percent.

Install them in main washrooms, corridors, in or adjacent to cafeterias, workshops and laboratories.



For latest data—drop a line today for Catalog 5601... BRADLEY WASHFOUNTAIN CO., 2227 W. Michigan Street, Milwaukee 1, Wis.



BRADLEY
Washfountains

Distributed Through Plumbing Wholesalers

and-stainless steel drinking fountains



Here are the latest in ultra-sanitary, long-life Counter Type Drinking Fountains—the model shown above equipped with one bubbler and one glass filler faucet. Bowls are full stainless steel with stainless steel mounting rim—easy to keep spotlessly clean with minimum maintenance.

The Bradley line of Drinking Fountains also includes pedestal, single and multiple types. Write for latest specifications.

Adhesive Application of Tile

Adhesive application of ceramic, plastic and metal tile to gypsum plaster has been approved by the Gypsum Association. The new recommended specifications, developed after several years of research, are designed to supplement those included in the Standard Specifications for Lathing and Plastering of the American Standards Association. Heretofore, architects have required the application of ceramic, plastic and metal tile to portland cement plaster. The new specifications, available from manufacturers of gypsum products, require the application of a primer coat and then the spreading on of the adhesive to receive the tile.

JOINT PROMOTION SCHEDULED BY WOOD ASSOCIATIONS

Representatives of ten major associations in the wood industry have joined together to formulate plans for an exchange of information and joint promotional activity among the member groups. The first joint project to be undertaken, a national promotion of store and office improvement "with friendly wood," is being mapped out by a steering committee headed by Richard D. Behm of the Hardwood Plywood Institute. A test promotion in the Minneapolis-St. Paul area during February will be followed by a nation-wide effort later in the year. The joint action is based on a "package concept" of store and office improvement which encompasses the over-all design, including materials, doors and windows, flooring and built-ins as well as furniture and fixtures. Emphasis will be placed on local follow-through of national advertising and publicity, and cooperation between the various elements in each community.

Definition of Air Conditioning

To clarify the confused situation as to the proper definition of air conditioning, the American Society of Heating and Air-conditioning Engineers has prepared and adopted a new and simplified definition which reads: "Air conditioning is the process of treating air so as to control its temperature, humidity, cleanliness and distribution to meet the requirements of the conditioned space."