

NEW! THE OZALID STREAMLINER

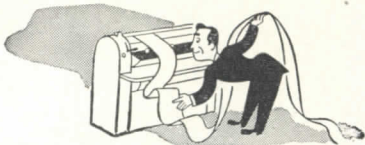

- Reproduces your engineering and architectural drawings in seconds—also your typed, printed, photographic material.
- Moderately priced . . . designed for the thousands of drafting rooms that want these 5 EXTRA VALUES in Printmaking at no extra cost—

1. EFFICIENCY! You always get positive (not negative) prints direct from your tracings . . . prints that are sharper, brighter, much easier for you to read, check, and make notations on.



You produce these without waste of material or waste of motion. Your tracings can be up to 42 inches wide, any length . . . and can be printed either on rolls of Ozalid sensitized paper or on cut sheets of matching size.

Your prints are always delivered dry, ready for immediate use . . . after just two simple operations—Exposure and Dry Development.



2. SPEED! ONLY 25 seconds to reproduce your standard-size tracings, specification and data sheets, etc.

3. ECONOMY! An 8½ x 11-inch reproduction costs you *one cent*; 11 x 17 inches, two cents . . . and so on. The Ozalid Streamliner soon pays for itself . . . in time, labor, and dollars saved.

With it, you can also effect amazing short cuts in design. For example—eliminate redrafting when changing ob-

solete drawings . . . combine the details of separate tracings on *one* print . . . re-



claim old or worn tracings . . . make transparent overlays in different colors.

4. VERSATILITY! You can reproduce the lines and images of any original in black, blue, red, sepia, or yellow . . . on paper, cloth, foil, film, or plastic.

Simply use the Ozalid sensitized material you think best for job at hand; e.g., use identifying colors for prints of separate departments or operations . . . DRYPHOTO to produce beautiful con-



tinuous-tone prints from film positives (which can be made from any negative)

. . . OZAPLASTIC to produce oilproof, waterproof prints for shop or field use. *All* prints are made in same fast, economical manner.

5. SIMPLICITY! NOW—printmaking is an easy desk job, automatic in practically every detail.

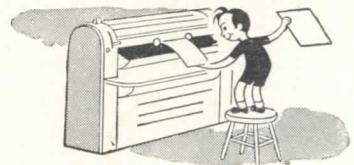

Anyone can feed originals and sensitized material into the Ozalid Streamliner. Prints are delivered on top, stacked in order—within easy reach of the operator, who does not have to leave her chair.

You can install your Streamliner anywhere; it requires only 11 square feet of floor space.

Write today for free, illustrated booklet . . . showing all the ways you can use the new OZALID STREAMLINER . . . and containing actual reproductions—like those you can make.

Gentlemen: DEPT. 264
Please send New Ozalid Streamliner booklet . . . containing reproductions of drawn, typed, printed, and photographic material. No obligation.

Name _____

Position _____

Company _____

Address _____

OZALID

DIVISION OF
GENERAL ANILINE AND FILM CORPORATION
Johnson City, New York

Ozalid in Canada
Hughes Owens Co., Ltd., Montreal

New

aluminum combination



Aluminum storm panels for metal casements also available

In construction products **CECO ENGINEERING**

storm panel and screen

- 1** You change from winter storm windows to summer screens in seconds—just raise the bottom panel.
- 2** Yet, if desired, the storm panels and screen are easily removed from inside the home.
- 3** This Ceco all-aluminum all-weather window and screen adds beauty to any style of architecture.
- 4** The frame is easily adjusted to the window opening by use of special closure sections.
- 5** Remains economical through the years. Maintenance is eliminated—no painting or repairing.
- 6** Storm panels and screens are easily washed at the sink—no standing on ladders.
- 7** Provides all-weather ventilation and protection—ends nuisance of frosted and steamed windows.
- 8** Saves up to 30% on fuel by keeping heat from dissipating through single glass panes.

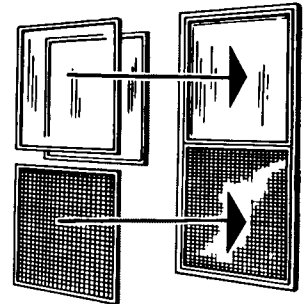

SELF STORAGE SAVES SPACE!

Leave all four parts of this amazing auxiliary window in place all year round. You change from winter storm windows to summer screens in a few seconds—just raise the bottom storm panel, as shown above. For winter, simply pull the storm panel down—no storage problem.

CECO STEEL PRODUCTS CORPORATION

GENERAL OFFICES: 5701 West 26th St., Chicago 50, Illinois

Offices, warehouses and fabricating plants in principal cities

**CECO
STEEL**

makes the big difference

MAIL

THIS COUPON FOR FULL DETAILS

CECO STEEL PRODUCTS CORPORATION

General Offices: 5701 West 26th Street
Chicago 50, Illinois

Please send me FREE folder on aluminum combination storm-panels-and-screen.

Name _____

Firm _____

Address _____

McCUTCHEON & DRAKE MOTOR CO., INC.
 Garage
 Beckley, West Virginia
 T. S. Rice—Designer
 G. T. Puckett, Heating Engineer
 Frank H. Wise, Heating Contractor
 Arnott-Swim Co., General Contractors

Here's a
NEW APPROACH
 in solving
 access
 problems...



Utilizing the roof of a garage for used car storage is good economics . . . but presents an access problem. An elevator installation is expensive. An inside ramp wastes valuable space. An outside ramp may, because of snow or ice, be unsafe or unusable many times during the year.

In this new garage, an interesting development is applied to keep the outside ramp navigable the year round. Coils fabricated from Byers Wrought Iron pipe are embedded in the concrete driveway slab, to serve as a snow melting system. Radiant heating, with Byers Wrought Iron pipe, is installed in basement and first floor of the building. Two boilers provide hot water, circulated by pumps, for the systems; a large boiler for radiant heating, a small one for snow melting.

No radiant heating is installed in the roof, but the entire area is kept dry by utilizing radiant heat from the first floor, through drop panels in the insulated ceiling boards. These are opened until any snow or ice on the roof has

been melted, and then closed.

This is the first use of snow melting in a garage ramp of which we have record. A number of combination installations have been made or projected, however, in which the snow melting portion of the system is used to keep driveways and service areas clear.

If you have followed radiant heating and snow melting installations you have noticed that in practically every case the pipe material used is wrought iron. The reason for this is found in the unusual combination of desirable

service properties that the material offers. It is easily bent and welded, which speeds installation. It has a high rate of heat emission. It expands and contracts at practically identical rates with concrete, minimizing the danger of thermal cracks and loss of bond. And finally, it has exceptional resistance to the corrosive conditions that are almost always encountered.

If you are interested in snow melting, ask for Case Study No. 4, which illustrates and describes several installations.

A. M. Byers Co., Pittsburgh, Pa. Established 1864. Boston, New York, Philadelphia, Washington, Atlanta, Chicago, St. Louis, Houston, Salt Lake City, Seattle, San Francisco.

CORROSION COSTS YOU MORE THAN WROUGHT IRON

BYERS
 GENUINE WROUGHT IRON
 TUBULAR AND HOT ROLLED PRODUCTS
 ELECTRIC FURNACE QUALITY ALLOY AND STAINLESS STEEL PRODUCTS

ARCHITECTURAL RECORD



Copyright 1947 with all rights reserved F. W. DODGE CORPORATION • Vice-President in charge of Magazine Division, H. Judd Payne • **EDITORS:** Editor-in-Chief, Kenneth Kingsley Stowell, A.I.A.; Managing Editor, Emerson Goble; Senior Associate Editor, Douglas Haskell; Associate Editors, John W. Ragsdale, James S. Graham, Jr.; Associate in South America, Edmund J. Whiting, A.I.A.; News Editor, Florence A. van Wyck • **ART DEPARTMENT:** Myron S. Hall, 3rd, Director; Peter Piering, Consultant; Sigman-Ward, Drafting • **CONSULTANTS:** Industry Relations Consultant, Thomas S. Holden; Statistical Consultant, Clyde Shute; Building Economics Consultant, Norbert Brown; Field Research Consultant, Clifford Dunnells, Jr.

COORDINATING THE COORDINATORS	85
An Editorial . . . by Kenneth K. Stowell	
DRAMATIC PRESENTATION OF SOUND	86
Display Rooms for RCA Victor Division, Radio Corp. of America, Camden, N. J. Carroll, Grisdale and Van Alen, Architects	
DESIGN FOR DEMONSTRATING DESIGN I.	95
Offices and Laboratory for Walter Dorwin Teague, New York City	
DESIGN FOR DEMONSTRATING PLASTICS	100
Quarters for Industrial Design Staff, General Electric Plastics Division	
FRONT OF GOLD WITH DUAL MEANING	102
Eddy Harth's, Beverly Hills, Calif. Paul Laszlo, Designer	
WHOLESALE RUG AND YARN SHOWROOM	104
James Lees & Sons Co., Merchandise Mart, Chicago. Raymond Loewy Associates: J. Von Der Lancken, Leon Hyzen, Architects	
ANSONIA SHOES IN A FLORIDA SETTING	108
Morris Lapidus, Architect	
CARPET SHOWPLACE FOR BUGGY TRADE	110
Carpet Mart, Hempstead, N. Y. Herman H. Siegel, Architect; Ernest D. Rapp, Designer	
MERCHANDISING TWIST FOR ATOM ERA	113
Cinemart: A Proposal by Roderick Seidenberg, Architect	
PRIZE-WINNING CHURCH DESIGNS	114
BUILDING TYPES STUDY NO. 125 . . . HOUSES	118
HOUSES ARE FOR HUMANS	118
SIMPLIFIED SMALL HOUSE PLANNING	122
By Victor Civkin, A.I.A.	
PROJECTS	124
Houses for an Arizona Community. William Wilde, Architect 124	
Houses for Thomas T. Crenshaw and Milo D. Folley, Syracuse, N. Y. Sargent-Webster-Crenshaw & Folley, Architects 128	
House for Mr. and Mrs. William Davey, Monterey Peninsula, Calif. Richard J. Neutra, Architect 130	
House for Dr. and Mrs. Irving I. Cowan, Milwaukee, Wis. George Fred Keck, William Keck, Architects 132	
House for Mr. and Mrs. Jerrold T. Kelly, Barrington, Ill. George Fred Keck, William Keck, Architects 133	
House in Chattanooga, Tenn. Gill and Bianculli, Architects 134	
ARCHITECTURAL ENGINEERING	135
Technical News and Research	
ADVANCES IN HOUSE HEATING	135
By Clifford Strock	
THE SCHINDLER FRAME	143
By R. M. Schindler	
PRODUCTS	147
for Better Building	
ADVANCES IN HOUSE LIGHTING	148
By E. W. Commerly	
TIME-SAVER STANDARDS	153
House Lighting Techniques	
MANUFACTURERS' LITERATURE	154
THE RECORD REPORTS	7
News from the Field	
A NEW CLIMATE FOR HOUSING	24
CONSTRUCTION COST INDEXES	26
REQUIRED READING	28
EMPLOYMENT OPPORTUNITIES	218
INDEX TO ADVERTISEMENTS	234

Architectural Record (combined with American Architect and Architecture) is published monthly by F. W. Dodge Corporation, 10 Ferry St., Concord, N. H., with Editorial and Executive Offices at 119 West 40th Street, New York 18, N. Y. Thomas S. Holden, Pres.; Howard J. Barringer, Vice-Pres. and Treas.; Irving W. Hadsell, Vice-Pres.; Chauncey L. Williams, Vice-Pres.; Sanford D. Stockton, Jr., Secy.; Walter F. De Saix, Asst. Treas.; Edwin H. Freed, Asst. Treas. Member Audit Bureau of Circulations and Associated Business Papers, Inc. Architectural Record is indexed in Reader's Guide, Art Index and Industrial Arts Index. Subscription rates: United States and Possessions, Canada, Cuba, Mexico, Central and South America, and Spain, \$4.50 the year, \$7.50 for two years, \$9 for three years; elsewhere, \$6.50 the year, \$11.50 for two years, \$15 for three years. Single copy, \$1. Circulation Manager: Marshall T. Ginn. Every effort will be made to return material submitted for possible publication (if accompanied by stamped, addressed envelope), but the editors and the corporation will not be responsible for loss or damage. Other Dodge Services: Real Estate Record & Builders' Guide, Sweet's Files, Home Owners' Catalogs, Dodge Reports & Dodge Statistical Research Service.

Adjustable Flush Valves

"All flush valves shall have an external adjustment for length of flush."

**PREFERRED BY
7 OUT OF 8
ARCHITECTS***

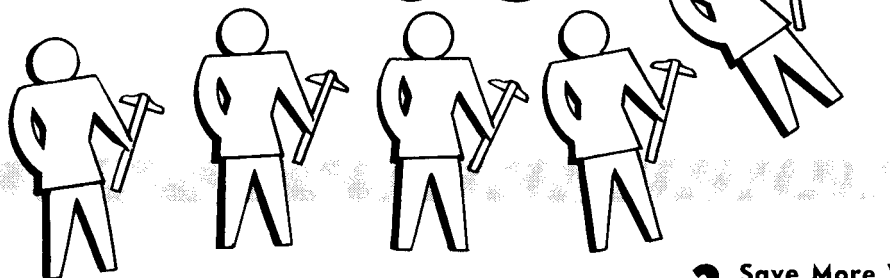

* Based upon 288 replies from a survey made among 500 architects on the question: "Do you feel it is an advantage to be able to adjust a flush valve for length of flush after it is installed on a fixture?"

To the overwhelming majority of architects, the adjustable feature means flush valves at their best. To many, too, adjustable means Watrous, because Watrous pioneered the idea, and because *all* Watrous flush valves are adjustable. Here are just 3 of the many benefits to be expected when your specifications call for Watrous adjustable flush valves.

1 Fixtures Operate More Efficiently

Since fixtures differ in their water requirements, *only* with adjustable flush valves can the exact coordination of fixture and flush be obtained to get top operating efficiency.

2 Save More Water

By delivering only the amount of water required for the fixture on which it is installed, an adjustable flush valve often saves an extra half gallon or more of water on each flush. In a building with 500 flush valves this can amount to extra savings of 1,460,000 gallons or more of water per year.

3 Efficiency Maintained Even After Years of Service

Over the years, normal wear and foreign material in the water are bound to change operating conditions. When flush valves are adjustable, compensation for these changes can be readily made to maintain maximum operating efficiency.

THE IMPERIAL BRASS MANUFACTURING CO.

1240 West Harrison Street, Chicago 7, Illinois

For complete information on Watrous Flush Valves see Sweet's Catalog, or write for Catalog No. 448-A. Also ask for Bulletin No. 447 giving a summary of "Architects' Views on Flush Valve Applications".

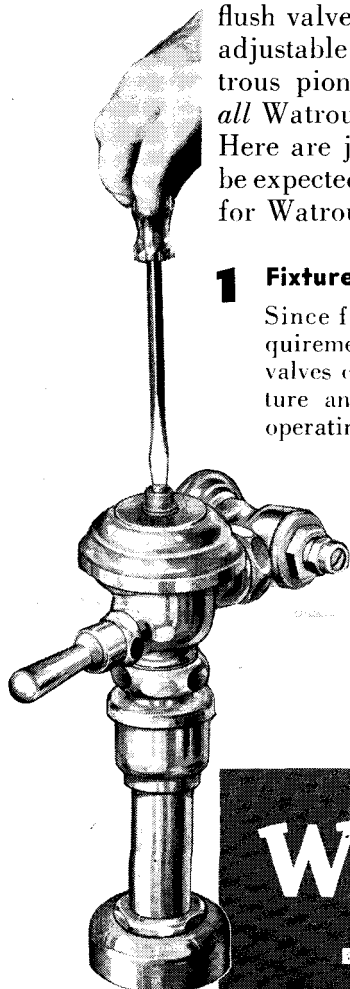

**Watrous Adjustable
Flush Valves**

BOTH DIAPHRAGM AND PISTON TYPES



THE RECORD REPORTS

Banking Authorities Watch Real Estate • Consumer Resistance Is Felt • Building Controls Dwindle Ann Arbor Holds Conference on Hospital Planning

Questions of mortgage money, which scarcely had been a consideration since prewar days, have started to insinuate themselves into the housing picture. A year ago banks were ready to lend almost on anything. Appraisers were going along with the market. The ease of the market was reflected clearly in the growing disuse of FHA insurance, which banks no longer insisted on and which builders, therefore, did not need.

Since then, however, the banking authorities in Washington have become control conscious once more. During the war they took it for granted that too much money was around to supervise. Ambitions to regain lost powers have been stirred up.

Real Estate Being Watched

The various supervisory agencies more recently have been lecturing the examiners who pry into banks' books. Examiners are told to watch real estate which worries the administration. And examiners admonish those bankers who failed to arrive independently at the same point of view. The admonitions, spokesmen for the banking agencies say, are being taken to heart as, they quietly add, "They'd better be."

This development obviously is easy to exaggerate and exaggerations may safely be forecast as banks bit by bit narrow their conceptions of "bankable property." The general money picture is, of course, still one of enormous liquidity, the newest qualifications notwithstanding. There is hardly any likelihood that building will be held down, except in particular cases, through lack of sufficient financing.

Although the banking authorities are most critical of real estate portfolios, they don't stop there. They are also becoming more alive to inventory situations of various building materials. But so far this caution does not blanket any particular material: no circular has been sent out, for instance, advising examiners to watch lumber, say, or cement or plumbing fixtures. Cases of overborrowing in these fields have come up from time to time, nevertheless.

The change is indicated to some extent in FHA figures. Last fall FHA insurance was sought on no more than 7 per cent of the mortgage applications; since then the percentage has advanced to about 20 per cent. This is still far below the 40 per cent to 45 per cent peaks before the

war, but it is far above last autumn. The current FHA applications include the usual proportion of refinancing as homes are transferred, which has been a steady accumulation since FHA started.

The FHA is getting more applications to insure single family homes but its own prime interest is to stir up interest in apartments. Business in this department is still far below ideals which the government set but is picking up. Currently about one out of four applications is for a rental property, including, however, mere transfers of ownership.

A strong pick-up in apartment construction seems doubtful at present costs even if Congress punctures or gets rid entirely of rent control. Both government men and builders in Washington say that it is hard to make the figures add up. Costs are high; amortization and interest, therefore, even at low rates must eat into future income. Local real estate situations are unsure. How long present prices will hold up is unknown. Will a builder who goes along on present construction costs lose the value of his capital when and if materials prices drop? These factors, the experts think, won't stop but will deter rental construction.

Consumer Resistance Felt

While official pronouncements by government are optimistic, talk among builders, directly and through their

Washington associations, is quite the opposite as regards construction of private residences. Costs still fail to match what the public can afford. The market for \$10,000 homes remains firm but homes above this figure take longer to sell. The complaint of the builders, it should be noticed, is one that is characteristic of vendors everywhere: used to selling at once and without effort, a little effort in finding buyers is disturbing.

Public Building Demand Grows

Meanwhile, prospects seem to be tremendous for local public construction, although all sorts of difficulties must be resolved. Local governments are being pressed by Parent-Teachers Associations to repair old schools and build new ones. Facilities which were adequate before the war have worn out or are insufficient for increased student bodies. The local governments in general find that their borrowing capacities just now are at peak — but that building costs also are high. Many are waiting until costs drop, but as they wait they wonder whether declining building costs will be offset by rising interest rates on municipal bonds. The trend toward lower federal taxes, they are well aware, will reduce one present market for municipals — notably estates which want tax exemption.

Building Controls Dwindle

Erosion of building controls goes forward at the accustomed average rate and those who administer them readily admit that, except for budget experts, nobody now bothers to keep up with just what controls remain in force. Both executive and administrative branches have been hacking away at them. The administration would like to retain some kind of power over cast iron soil pipe,

(Continued on page 10)

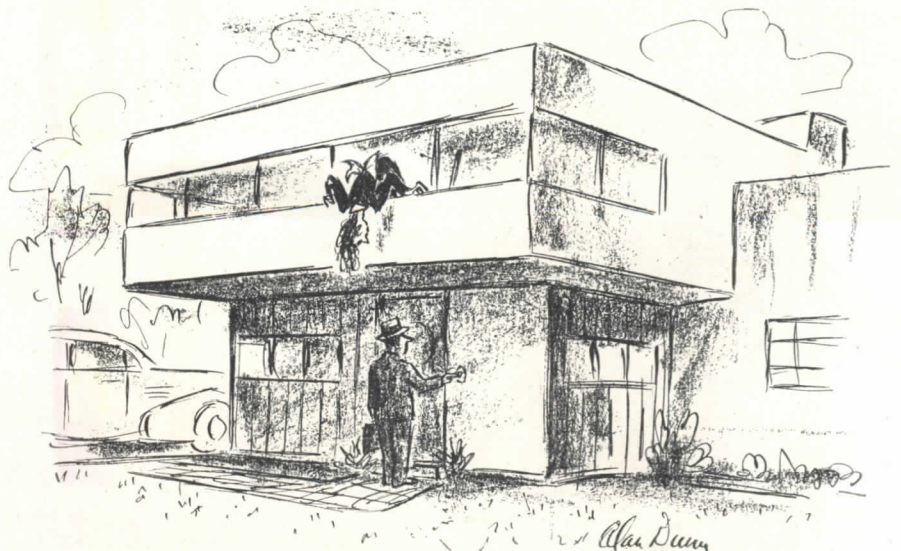

— Drawn for the RECORD by Alan Dunn



**GIVE YOUR
CLIENTS**

Double-

OUTSIDE: Specify double-duty Insulite Sheathing and get two things for the price of one —

(1st) *Sheathing*

(2nd) *Insulation*

One material—double usage! That's double for the money—something your clients will appreciate. By certified test, Insulite Sheathing provides bracing strength superior to wood sheathing horizontally applied. Water proofed throughout, excellent weather resistance.

All this, PLUS insulation, so you can tell a client "Here's where your money buys double usage."

 **INSULATES AS IT BUILDS**

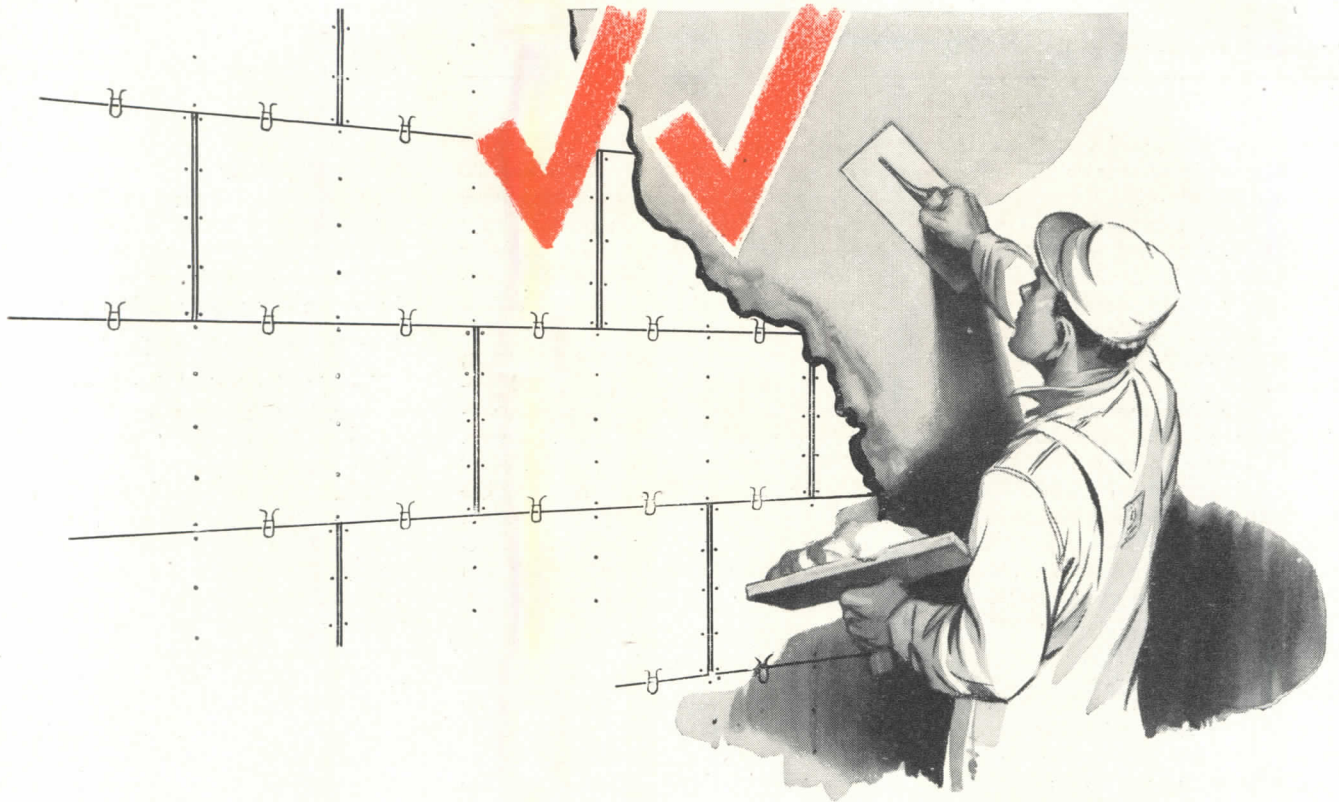

FOR THEIR MONEY!

INSIDE: Specify double-duty Insulite Lok-Joint Lath and get two things for the price of one —

(1st) *Plaster base*

(2nd) *Insulation*

One material—double usage! No spreading of joints—no “snap-back” of lath when troweling. Surface stays firm and level. Insulite Lok-Joint Lath, with vapor barrier, guards against condensation problems.

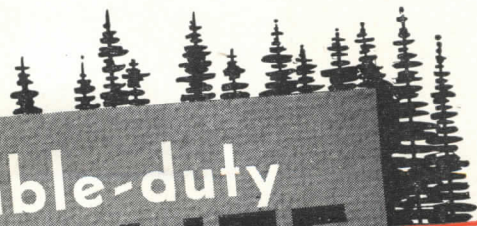

Refer to Sweet's
File, Architectural
Section 10 a/9

BUILDS AS IT

double-duty
INSULITE

The GENUINE

INSULATES

“Insulite” is a registered
trade-mark, U.S. Pat. Off.

DIVISION OF
PAPER
MINNEAPOLIS 2, MINNESOTA

 MINNESOTA & ONTARIO
PAPER COMPANY

pig iron, millwork and a few other items. It still considers its order limiting non-housing construction important. It is trying to work out schemes for voluntary allocations, but wants to allocate pig iron legally in the interest of getting soil pipe. It is still interested in the 1500 sq. ft. ceiling for single residences. It wants the veterans preference on new homes.

A House bill, however, eliminates all inventory controls over building materials, power to negotiate new contracts to guarantee sales, etc. The Banking Committees considering the continuation of controls heard a good deal of testimony from the industry that curbs failed to speed home construction. Questions of whether rent controls would remain hung in the balance.

Some Controls Remain

As of the close of the first quarter, these controls still were in effect legally and in some cases actually:

ANN ARBOR CONFERENCE

Hospital architects, consultants and doctors descended on Ann Arbor in such numbers that Dean Bennett must have wondered just what he had started. This, the third annual conference on architectural topics sponsored by the College of Architecture and Design, University of Michigan, was devoted to hospital planning, attracted such numbers of specialists as to crowd the rooms of the Union Building and pack the luncheons almost to the point of second tables.

Doctors selected for the speakers' panel talked to the architects, the architects talked to each other and to the doctors, and nurses were present to talk up to both. But as the discussions waxed more heated the groups broke ranks until there seemed to be complete disagreement all around. Which is one way of saying that the conference really got down to cases, progressed beyond the stock phrases and stock plan solutions, and clearly demonstrated that hospital planning neither admits of standard solutions nor puts any ceiling on ingenuity. Dean Wells Bennett played the gracious host and let his performers attack each other with uninhibited enthusiasm.

The program began, at a low level of controversy, on Thursday evening, April 3rd, with a session on the veterans' hospital program, by Lt. Col. Harry E. Brown of the VA, and H. Eldridge Hannaford, architect, with Addison Erdman, architect and author, and Roy Hudenberg, Secretary, Council on Hospital Planning and Plant Operation, American Hospital Assn., leading discussion.

Non-residential building held to \$50 million weekly; veterans preference, 30 days on sales and 60 days on rentals; new units limited to 1500 sq. ft. with only one full-size bathroom; no summer residences; dealers inventories controlled for lumber, millwork, electrical fixtures, plumbing items, etc.; rent ceilings on new apartments or homes; pig iron allocated for soil pipe and premiums still paid on the pig; new contracts guaranteeing prefabricated houses.

Of this array Creedon was described as being most insistent on retaining the limit on non-residential construction, while members of his staff were investigating the extent to which the ceiling was needed.

Taft Bill Hearings End

The Senate Banking Committee, after listening to a volume of testimony by both proponents and opponents of the Taft bill (S. 866) decided that the time had come to stop. Sufficient evidence

Another session was devoted largely to the Hospital Survey and Construction Act, handled by George Bugbee, Executive Director, American Hospital Association, and Marshall Shaffer, chief architect for the U. S. Public Health Service. The Michigan hospital program, carrying along this federal effort, was described by Graham L. Davis, Director, Division of Hospitals, W. K. Kellogg Foundation, and Lewis J. Sarvis, architect, and Adrian Langius, architect and director of Michigan's building program.

Dean Joseph Hudnut, Harvard, pleased his luncheon listeners with a typical bit of Hudnut inspiration in anecdote, springing from the story of his visit to an unusually depressing new hospital, which, according to its superintendent, was "planned by so many experts, was so functional, that we had no need for an architect."

The plain speaking really began with a talk by Dr. Basil C. MacLean, of Strong Memorial Hospital, Rochester, who challenged architects with a "major and a minor decalog," and continued by Dr. Robert H. Bishop, Jr., Director of University Hospitals, Cleveland; Isadore Rosenfield, architect and hospital consultant; Thomas F. Ellerbe, architect who has done the Mayo work; Nathaniel A. Owings, of Skidmore, Owings & Merrill, architects; and others.

The program was arranged by a committee consisting of: Kenneth L. Black, chairman; Amedeo Leone, Alden Dow and Walter Rolfe, Alden Dow was named chairman of the conference for the coming year.

had been collected on both sides by the last Congress. The decision to limit testimony suggested a favorable report by the Committee; there is said, however, to be considerable opposition through Congress.

The hearings themselves largely repeated those of last year, as the Committee finally agreed to discover. Lists of witnesses were closely correlated as well as the things they had to say.

New Techniques Described

Use of technological development for mass production of houses was described before a House hearing by one of its prime champions, Carl G. Strandlund, president of Lustron Corporation, financing of which by RFC had been insisted on by Wilson Wyatt some months ago. Speaking for the National Association of Housing Manufacturers, of which he is now president, Strandlund said that houses to be "manufactured by the companies in this new industry" will range in price from \$5500 to \$7000, land excluded. The deluxe model by his own company is 31 by 35 ft. and includes 1000 sq. ft. of usable space, with some built-in furniture. Costs will drop and materials too.

"The manufacturers of these houses," he said, "are using the very best architectural talent available because the cost for this service will be spread over a large production schedule. As a result, beautiful designs are being achieved which will have a great appeal to the consumer." He said one of his models has 36 different effects so that in a 36-home project no two would be identical. He said that 20 companies are in the field of mass production.

Labor legislation was delayed many weeks by disagreement within committees on how far Congress should go. Disagreement reflected both primary differences among legislators and consideration of a possible executive veto. But it was clear that all groups agree to get rid of secondary boycotts such as had affected construction in many areas. Building industry closed shop contracts, it appeared, would not be disturbed.

Labor Decisions Made

Meanwhile the Supreme Court decided against the Brotherhood of Carpenters and in favor of lumber interests which charged that they were being kept out of the San Francisco Bay area of California. Outside millwork was kept outside. Such prosecutions previously had been stopped by virtue of a clause in the anti-injunction act which bars action against trade union or trade association officers without clear proof of individual guilt. Court finally decided that this does not apply to anti-trust case actions.

(Continued on page 12)

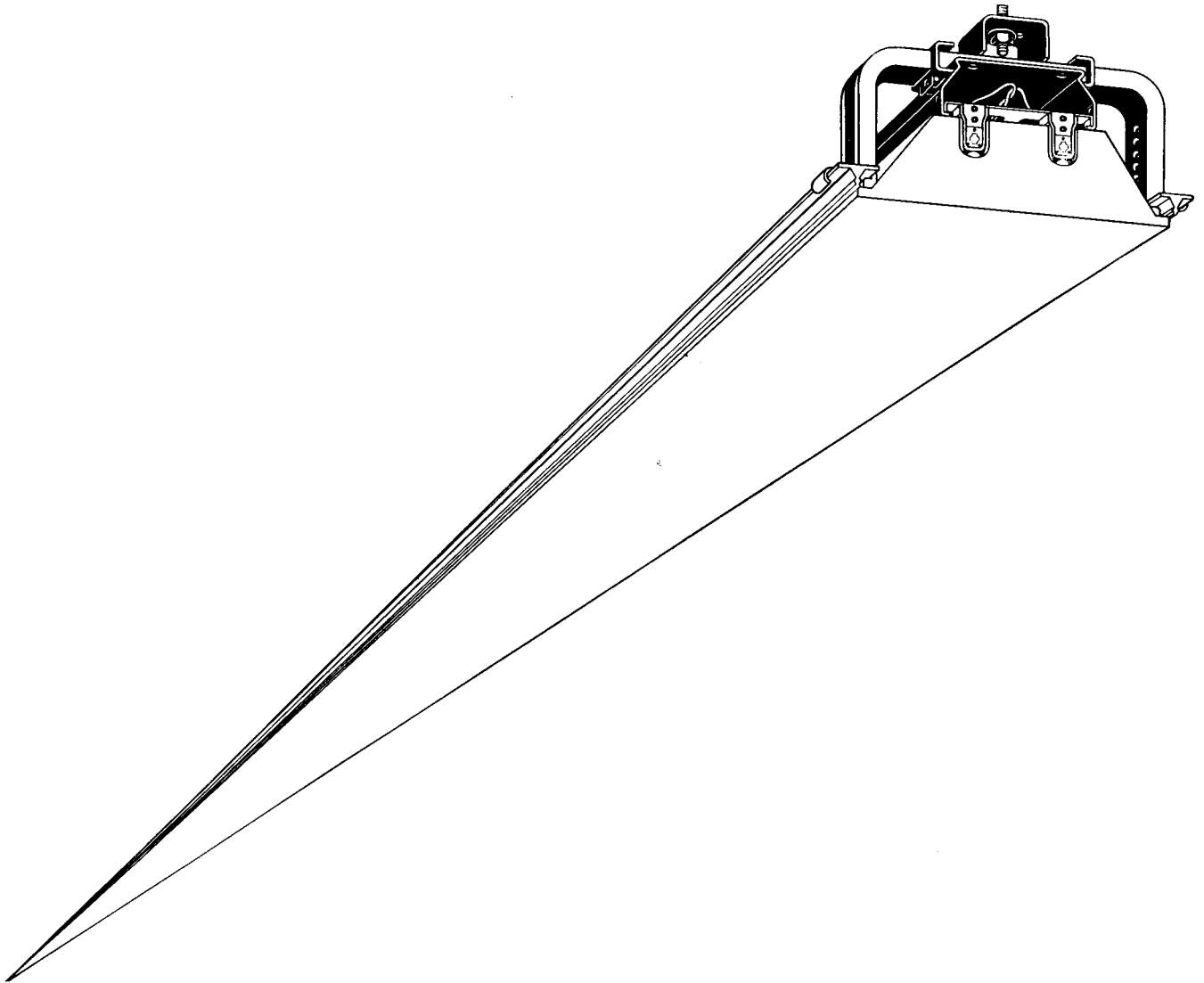

EASY-SEEING LIGHT . . . plus CEILINGS UNLIMITED

MILLER FLUORESCENT TROFFER LIGHTING SYSTEMS not only provide light for "easy seeing" . . . they make it possible for the interiors of stores, offices, schools, factories and public buildings to be planned around the lighting — to use the lighting as a structural aid to form any ceiling pattern desired — CEILINGS UNLIMITED! The MILLER CEILING FURRING HANGER (patented), hung from structural ceiling, supports both furred ceiling and lighting system and makes possible a boundless versatility of lighting application. Simplified installation. 50 to 80% cut in wiring, conduit and conduit fitting costs. More "above ceiling space" for piping and air-conditioning ducts.

Miller lighting service, developed over 103 years' pioneering in good lighting, is all-inclusive. Its 50 and 100 FOOT CANDLERS (Continuous Wireway Fluorescent Lighting Systems) have been established as standard for general factory lighting. And its Incandescent and Mercury Vapor reflector equipment have broad factory and commercial application.

MILLER field engineers and distributors are conveniently located.

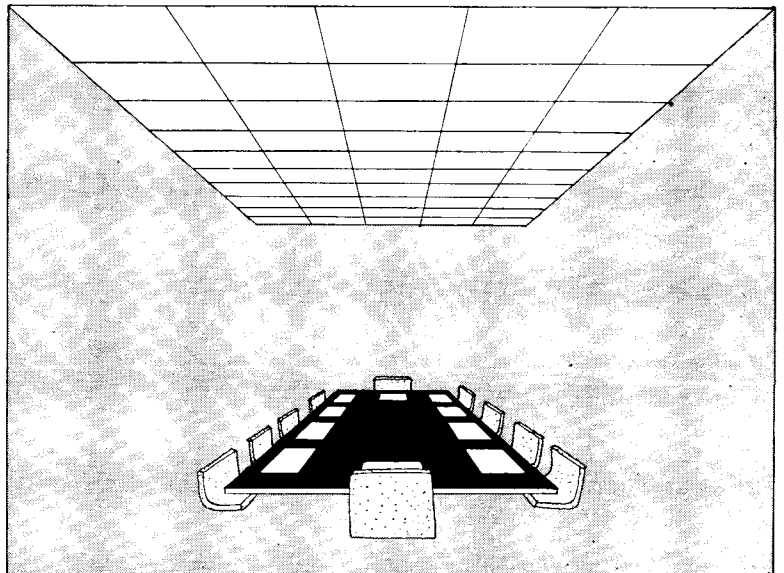

THE MILLER COMPANY

Illuminating Division, Meriden, Connecticut

ILLUMINATING DIVISION
Fluorescent, Incandescent
Mercury Lighting Equipment

HEATING PRODUCTS DIVISION
Domestic Oil Burners
and Liquid Fuel Devices

ROLLING MILL DIVISION
Phosphor Bronze and Brass
in sheets, strips and rolls

(Continued from page 10)

COST PEAK REACHED?

Fifty-three per cent of 268 general contractors in all parts of the country polled by F. W. Dodge Corporation, believe that the peak in construction costs has been reached.

In some areas, notably New England, the South Atlantic states and the East South Central states, opinion was preponderant, at least two to one, that costs had attained their highest level. Only in the Pacific states was opinion general that the peak had not been reached, and here further cost climbs ranging from 11 to 12 per cent during the current calendar year were expected.

The minority — 126 of the contractors polled — believe that further increases can be expected, the average increase anticipated by them being 8.7 to 10.2 per cent above current levels.

The poll also indicated that prices for most building materials, with the exception of lumber, Portland cement, structural steel and cast-iron soil pipe and fittings, have tended to remain stable since January 1st.

WHAT THEY SAY . . .

About Housing

"There is no place in this country for a peacetime housing czar as proposed in the Taft-Ellender-Wagner housing bill. . . . The construction industry itself proposed the creation of a housing commission of the general type specified in the bill to coordinate the activities of the various federal agencies dealing with housing matters, but there is no need whatsoever for a permanent housing administrator. In the effort to justify his existence on the payroll and to expand the scope of his authority, an overall housing administrator inevitably would attempt to maintain governmental control of the building industry. . . . Although the administrator is described in one part of the bill as a mere coordinator of housing activities, other sections make him the director of a far-flung urban redevelopment program and make him responsible for public housing policy. We hold that these diverse responsibilities are incompatible. . . . If there is to be an agency devoted to public housing, it should be separate from those agencies which are devoted to helping private enterprise meet the nation's housing need." — Douglas Whitlock, Chairman, Building Products Institute.

"Not more than 50,000 permanent dwelling units completed in 1946 were for rent exclusively. The reason for this small total is that risk capital just cannot be expected to invest in rental construc-

(Continued on page 14)

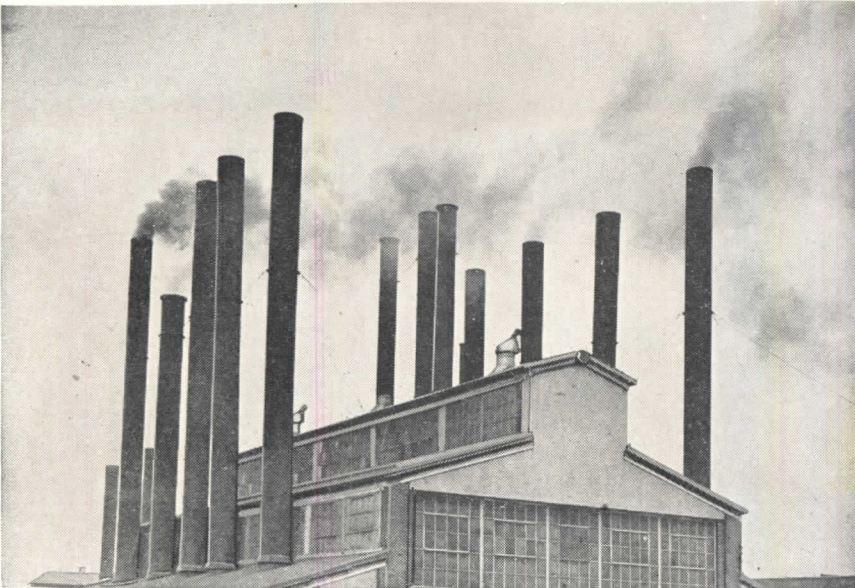

Here's Exhaust Efficiency --- Without Bulky Equipment

Effective *space-saver* for exhaust installations! The Propellair drum-type fan is actually a short stack or duct section. It mounts vertically, horizontally, or at any angle—often without additional support.

Specifically adapted to handling gases of corrosive characteristics, excessive temperatures, or high moisture content, drum-type fans have motor located *safely* and *conveniently* outside air stream. Fan bearings are cooled, when necessary, by outside air drawn through the tube enclosing the belt drive.

Fumes and smoke from 12 brass-melting furnaces at Mueller Brass Co., Port Huron, Mich., are whisked away like magic by 12 Propellairs which help maintain their "*very satisfactory*" working conditions.

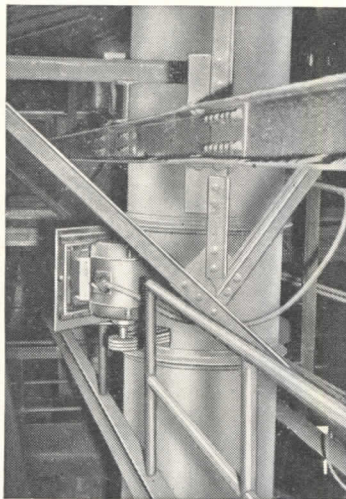

• Propellair drum-type fans mount directly in stacks or ducts—require practically no space at all. Mueller's Plant Engineer, J. W. Tielking, says, "They're easy to install in crowded quarters."

FOR EVERY INDUSTRIAL VENTILATING NEED

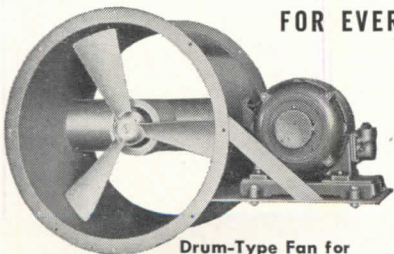

Drum-Type Fan for stacks and ducts

Heat, moisture, dust, and fumes vanish quickly and *completely* in the powerful suction and strong exhaust of Propellair fans. Airfoil blades *pull* even more than they *push*—deliver uniform air flow over whole fan area. Types, sizes, and mountings for every industrial use. Write today for interesting facts.

"MOVING AIR IS OUR BUSINESS"

PROPELLAIR

DIVISION OF ROBBINS & MYERS • INC.

SPRINGFIELD • OHIO

Save tomorrow's costs — today

Meet today's needs—and match tomorrow's—with Bulldog BUStriction Systems
... BUStriction DUCT for plug-in power and Ventilated Lo-X Duct for feeder lines.

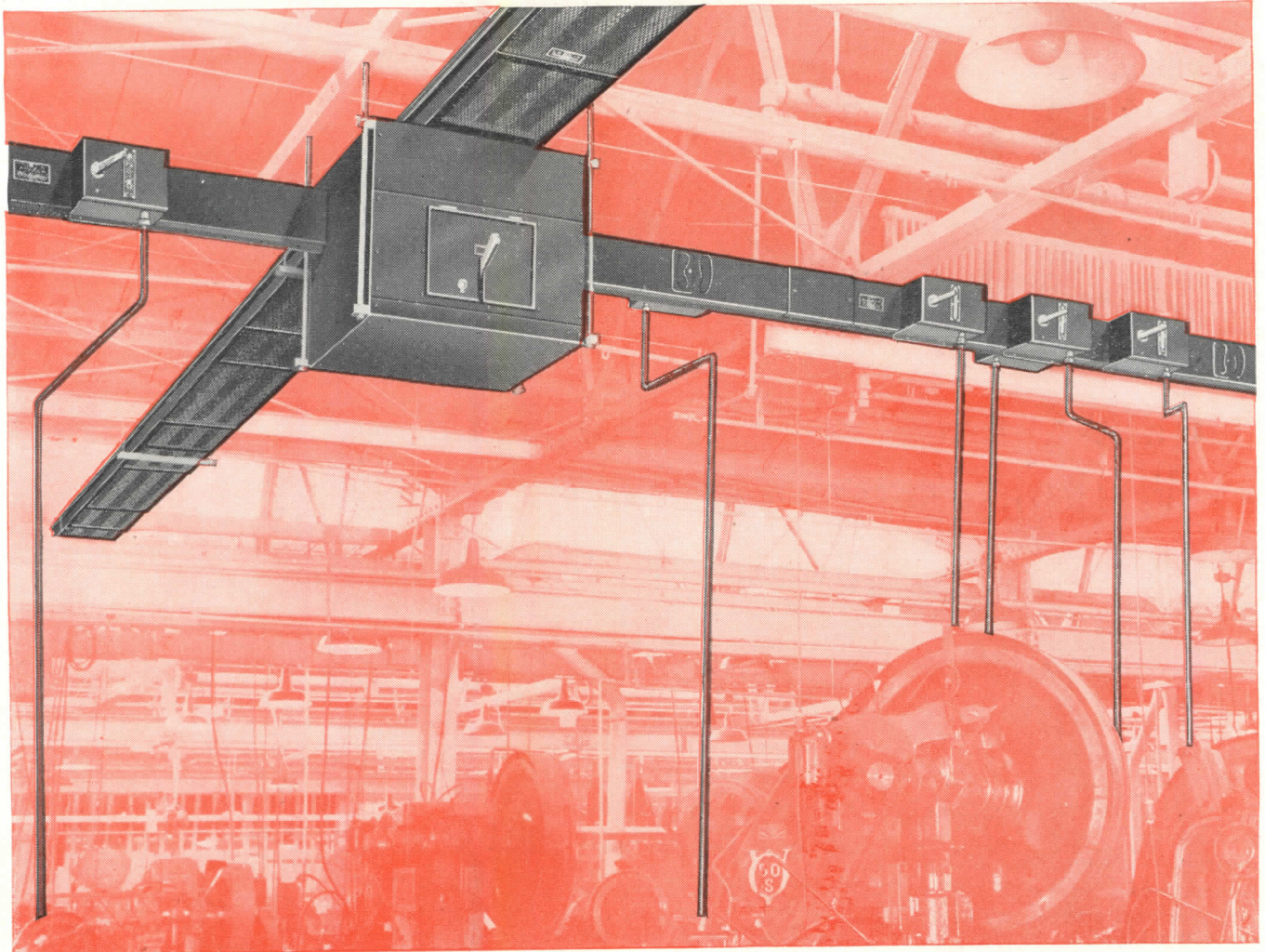

Bulldog Lo-X Feeder Duct blocks two blows at plant efficiency—voltage drop and temperature rise.

When voltage drop pinches power supply, output of motors and lights must suffer. And when temperature rise reaches dangerous heights, heat takes its toll on the life of the distribution system.

But Bulldog Lo-X helps you to lick both of these problems for your clients. Unique design and arrangement of the bus bars, plus adequate ventilation, insures maximum conductivity and rapid dissipation of heat.

Economy doesn't stop there, either. Rugged construction cuts maintenance costs, and when major production changes require alterations of feeder lines, Bulldog Lo-X can be dismantled, moved and reinstalled with complete re-use of all materials.

Bulldog Plug-In BUStriction DUCT meets the challenge of change.

Machines can be moved and be back in production with minimum losses in time and in effort, thanks to the high flexibility of this modern branch circuit system.

Every ten-foot section of Plug-In BUStriction DUCT has ten convenient outlets. That means no re-wiring, no addition of fixed outlets. Electricians need only raise the plug to the nearest duct opening, snap its contact fingers over the bus bars and bolt the plug to the casing. The whole job can be done in a matter of minutes and without interruptions for the rest of the line.

Like all Bulldog Bus Duct systems, BUStriction DUCT is made in prefabricated, standardized sections for easy installation and for dismantling and reinstallation without scrapping any parts.

Call a Bulldog Field Engineer. He'll show you installations of these two modern systems in a plant close by. Or, write Bulldog direct for detailed folders.



BULLDOG

ELECTRIC PRODUCTS COMPANY



Bulldog manufactures Vacu-Break Safety Switches — SaffToFuse Panelboards — Superba and Rocker Type Lighting Panels — Switchboards — Circuit Master Breakers — "Lo-X" Feeder BUStriction DUCT — "Plug-in" Type BUStriction DUCT—Universal Trol-E-Duct for flexible lighting—Industrial Trol-E-Duct for portable tools, cranes, hoists.

Detroit 32, Mich. Field Offices In All Principal Cities. In Canada: Bulldog Electric Products of Canada, Ltd., Toronto.

(Continued from page 12)

NEWEST SILV-A-KING FLUORESCENT FIXTURE

THE

Vanguard

for commercial installations

2148 GL

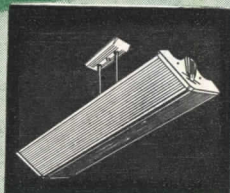
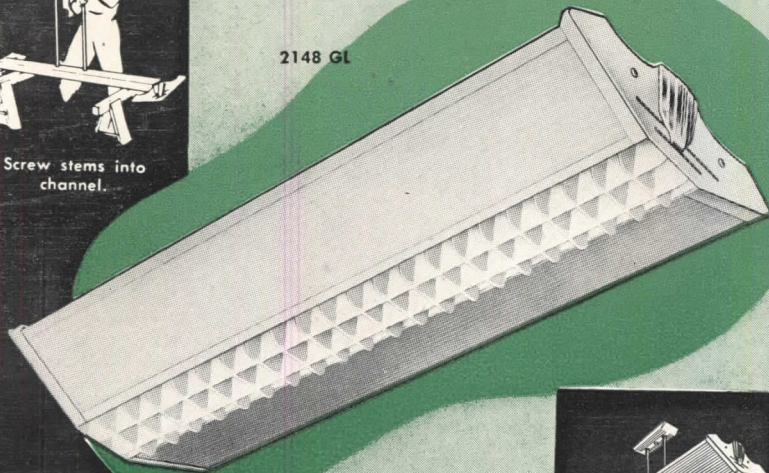

Can be suspended as illustrated

A quarter-century of quality engineering stands behind the new SILV-A-KING "Vanguard." Install it in offices, stores, showrooms, hospitals, and schools — to satisfy the most exacting demands!

"VANGUARD" QUALITY FEATURES:

LOUVRE Egg-crate louvre shields lamps, provides maximum diffusion.

SIDE PANELS Steel frames eliminate danger of sharp edges, add strength. Securely hinged to facilitate maintenance.

GLASS Frosted ribbed glass panels intensify light diffusion, remove glare.

FINISH All metal surfaces in high-temperature, baked white enamel of high reflectivity, lasting quality.

SLOTTED END PIECES Engineered to provide soft light glow. Eliminates dark ends.

CANOPY AND STEMS (Optional) Precision fitted. Matte aluminum finish.

STANDARDS I.B.E.W., A.F. of L.; approved and listed by Underwriters Laboratories, Inc.

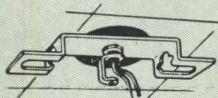

New-Type Hanger Strap, for easy suspension installation... a one man job!

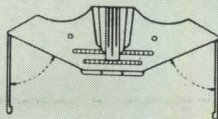

Hinged mechanism allows side panels to open and plumb themselves, for easy access.

Write for new "Vanguard" Bulletin!

BRIGHT LIGHT REFLECTOR COMPANY, INC.

Field at State, Bridgeport 5, Conn.
Subsidiary of Bridgeport Pressed Steel Corp.



Attach hanger strap to outlet box.



Screw stems into channel.

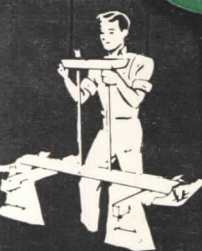

Slip canopy over stems.

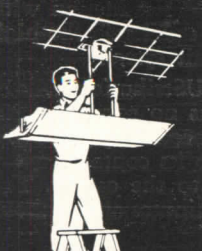

Slide stems into slots of hanger straps.



Position canopy. (The job is done.)

tion with the threat of continued control and continued economic discrimination which will prohibit a reasonable return on the investment." — *Herbert U. Nelson, Executive Vice President, National Association of Real Estate Boards.*

"Continuation of rent controls is holding up the construction of thousands of units of rental housing. . . . In a period when construction costs still are uncertain, investors hesitate to commit their funds to rental projects because the final cost of building may make it impossible for them to rent at the established ceilings except at a substantial loss. The alternative is to invest funds in other ways or to wait until ceilings have been eliminated either by Congress or by administrative action." — *Roy A. Shipley, President, Structural Clay Products Institute.*

"For decades our home production has been building more comfort and convenience into homes, but too often at higher prices. Now the tables must be turned so that better quality can be supplied without advancing costs. Technical advances, improved materials, more efficient practices already at hand make this possible." — *Morgan L. Fitch, President, National Association of Real Estate Boards.*

About the Budget

"Efforts to balance the federal budget could be expedited by returning to the Treasury about \$36,000,000 of unexpended funds appropriated last year for subsidies to building product manufacturers. Of the \$400,000,000 premium payment fund voted by Congress at the insistence of former Housing Expediter Wilson Wyatt and other Administration leaders, not more than about \$35 to \$40 million will have been spent by June 30 and the balance would serve no useful purpose if it were spent. . . . Only 10 premium payment plans ever were put into effect and all but four of these already have been terminated without any semblance of protest from industry." — *Douglas Whitlock, Chairman, Building Products Institute.*

CONSTRUCTION REPORT

Contracts awarded for residential construction in the 37 states east of the Rockies totaled \$465,810,000 during the first two months of this year as against \$191,794,000 during the corresponding period of 1946, F. W. Dodge Corp. figures show.

The total number of dwelling units called for in the January-February contracts was 60,846 compared to 26,103 in the same months last year. Eight per

(Continued on page 16)

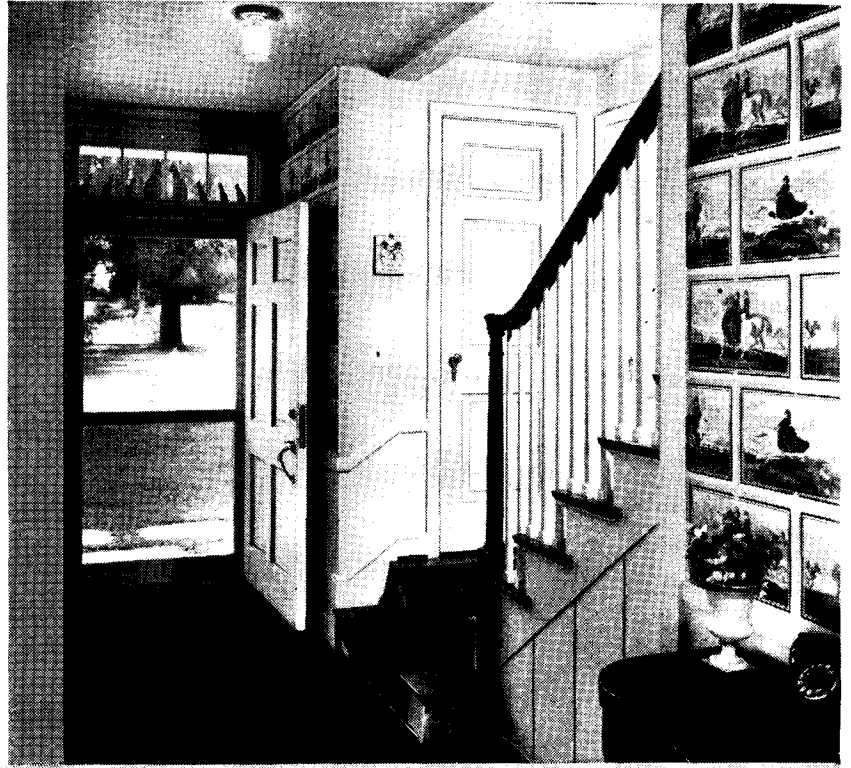

What Price Friendliness?

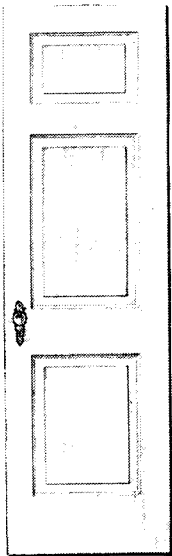

This 3-panel door — a variation of the standard Ponderosa Pine 6-panel door — is used in areas calling for a narrower door. Stock design doors of Ponderosa Pine are precision-made for better fitting. These doors sand satin-smooth for receiving paint, stain or varnish — the wood takes nails and screws without splitting. Ponderosa Pine door and window frames are properly seasoned and kiln dried — absolutely square, with joints that are made to remain tight.

Repeatedly, surveys show that people want houses that make them feel “at home” — friendly rooms in which architectural design provides a feeling of warmth and comfort.

You can create such interiors — at modest cost — with stock design Ponderosa Pine doors and windows.

Ponderosa Pine paneled doors capture light and shadow in interesting patterns — help you add character to dwellings you plan. Ponderosa Pine windows combine grace and charm with the natural insulating qualities of wood. And all Ponderosa Pine Woodwork is friendly to the owner's pocketbook — because smooth-grained Ponderosa Pine holds paint or other coatings easily — and because Ponderosa Pine is durable.

For reference, you'll want a copy of “Today's Idea House” — Ponderosa Pine's booklet containing photographs of typical interiors made friendly with Ponderosa Pine doors and windows. Mail the coupon for your copy!

For Friendly Living . . .
Ponderosa Pine
WOODWORK



Ponderosa Pine Woodwork
 Dept. PAR5, 111 West Washington Street
 Chicago 2, Illinois

Please send me a free copy of “Today's Idea House.”

Name

Address

City Zone State



Salter

**BUILT-IN QUALITY
is a luxury that can now
be enjoyed by everyone !**

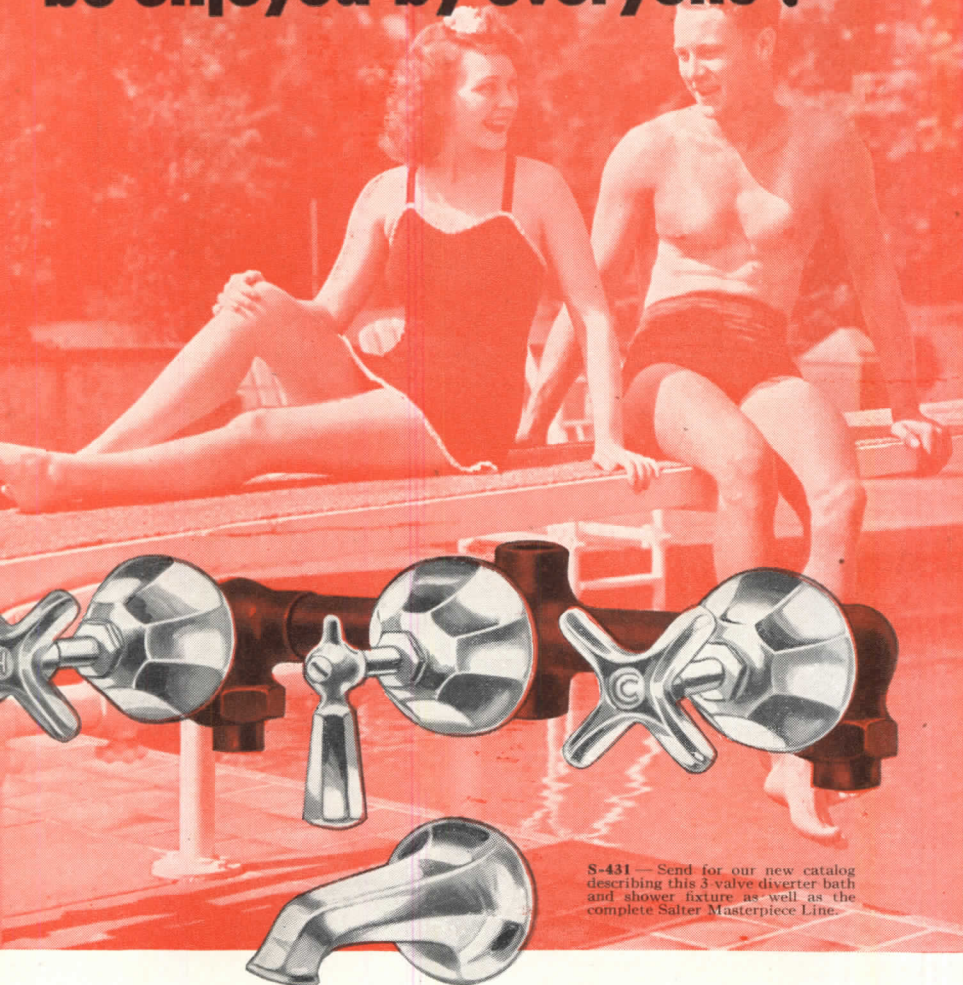

S-431 — Send for our new catalog describing this 3 valve diverter bath and shower fixture as well as the complete Salter Masterpiece Line.

The market for quality plumbing fixtures is no longer limited to those few who enjoy the luxury of a private pool . . . now most home owners anticipate the best . . . especially when costs are equal. The 3-valve bath and shower fixture illustrated, with its exclusive long life "EZE" close swivel-disc valve stem construction, heavy brass body, and mirror-like chrome finish, is typical of the luxury features found in all Salter-Glauber fixtures.

The completeness of the Masterpiece Line permits you to specify Salter fixtures on most of your plumbing brass goods specifications. And the production of seven specialized plants also assures sufficient quantities to meet building commitments. Build for the future with Salter luxury fixtures . . . capitalize on their popular acceptance.

H.B. Salter MFG. CO.

MASTERPIECES IN BRASS

10 Ninth Street, Marysville, Ohio

and division THE GLAUBER BRASS MFG. CO., Kinsman, Ohio

THE RECORD REPORTS

(Continued from page 14)

cent of these contracts, in dollar volume, were for publicly owned housing projects.

A sharp relative increase in apartment projects was noted, the number of dwelling units therein totaling 16,922 against 5,572 units in such projects during the comparative period of last year. Single-family dwellings erected by operative builders for sale or rent constituted the biggest volume this year with 35,456 dwelling units called for in the first two months compared to 15,119 in this classification in the corresponding period of last year.

Federal controls on nonresidential construction are reflected in the drop from \$438,185,000 in January-February, 1946, to \$343,570,000 in the same months of this year. Gains in heavy engineering works, however, offset losses in manufacturing and some other classes of nonresidential building, to make the total of all construction contracts \$1,013,825,000 for the first two months of 1947 against \$744,900,000 in the corresponding period of last year.

HOUSING ESTIMATE DOWN

Faced with a series of substantial union labor wage increase demands, running as high as 69 per cent greater than rates prevailing less than 18 months ago, earlier optimistic expectations of an increased volume of housing construction in the Long Island area are being revised downward sharply to a point bordering on complete cessation, by members of the Long Island Home Builders Institute.

At a recent Institute meeting, builders expressed the conviction that the proposed new wage rates, coupled with current labor conditions, low productivity and a shorter work-week will add up to sales prices that will price homes out of the market. Information from builders indicates that new housing construction currently under way is less than 20 per cent of that a year ago, the Institute points out, and reports of new construction projected for this spring reveal a universal decision on the part of builders to substantially curtail, and in many cases to completely abandon, plans for the start of new construction of veterans' and other housing.

FLORIDA CONSTRUCTION

General construction in South Florida for the next five years will approach the billion-dollar mark, say four of Miami's leading economic authorities: the Miami Builders Exchange, F. W. Dodge Corp., the Florida Power & Light Co., and the City of Miami Research Bureau. Fur-

(Continued on page 156)

WHERE OIL AND GASOLINE ARE BEING USED

GUARD THE BUILDING

AGAINST **FIRE** AND **EXPLOSION** HAZARDS
AND **WATER POLLUTION**

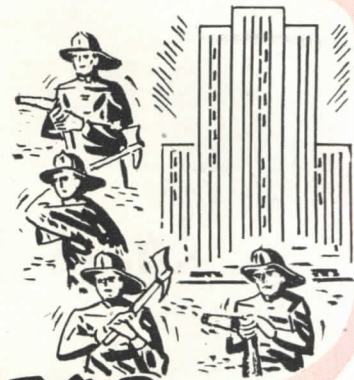

Josam

WITH THE OIL INTERCEPTOR

There's dynamite planted in the building where gasoline, naphtha, oil or other inflammable or volatile liquids are being poured, or are constantly seeping, into the drains. A carelessly dropped match, a lighted cigarette or spontaneous combustion will set off a subterranean explosion with the force of dynamite! The proper way to prevent such explosions and fires in

garages, factories, airports, refineries, dry cleaning plants, and similar places, is to install Josam Oil Interceptors. Josam Oil Interceptors prevent inflammable residues from entering the drain lines and positively eliminate dangerous hazards. The cost is so small compared with the protection they provide to property, equipment, merchandise...and life itself!

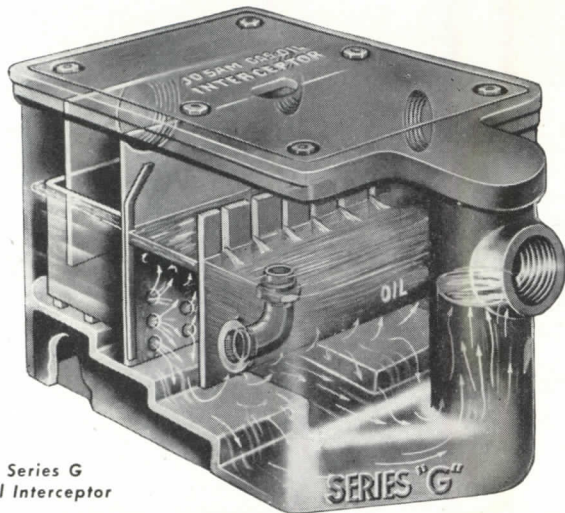

Series G
Oil Interceptor

- With the Josam Oil Interceptors located in proper points in the drainage system, the inflammable liquids are eliminated from the waste water and safely drawn off. Josam Series G Oil Interceptor is a proven unit in the field of gasoline and oil interception... separates these substances from the water through construction which is based upon the hydraulic principle of the cascade. Clean water continues through the trap leg to the drain line and to the sewer, free of the bulk of contaminating oils or similar liquids which carry the hazard of fire, explosion as well as pollution.

The gravity draw-off drains off the accumulated oil, gasoline, and similar light density substances above operating level to safe storage tanks or containers for salvage use or sale.

Each Josam Oil Interceptor is equipped with a flow control which governs the rate of flow to the interceptor to prevent overloading and to insure 90% or more efficiency.

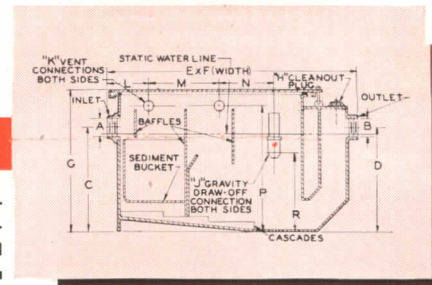

Series GN Oil Interceptor

FOR HEAVY DUTY COMMERCIAL AND INDUSTRIAL SERVICE — SERIES GN

- Large commercial and industrial plants... where kerosene, gasoline, oil, naphtha and other light density substances are present in waste water as a basic or by-product of the process carried on in the establishment... not only can salvage such liquids to good advantage but are often confronted with law infraction when they allow them to pass with waste water to the sewer. In most cases, the tremendous flow rates and high efficiencies required to provide the proper protection have placed the requirements beyond the capacity of regular oil interceptors.

For this specific purpose, Josam has developed its Series GN Oil Interceptors in a wide range of large capacities, designed to render heavy duty service while maintaining high efficiency and providing the Josam method of gravity draw-off. For further information on Josam Oil Interceptors, send coupon below today.

- Floor Drains ● Roof Drains ● Moderator Shower Mixing Valves ● Grease Interceptors ● Swimming Pool Equipment ● Oil Interceptors ● Backwater Valves

JOSAM MANUFACTURING COMPANY

General Offices, Ferguson Bldg., Cleveland 14, Ohio • Plant, Michigan City, Ind.

Representatives in all Principal Cities

JOSAM-PACIFIC CO., West Coast Distributors
765 Folsom Street, San Francisco, California

EMPIRE BRASS COMPANY, LTD., Canadian Distributors
London, Ontario



See our Catalog in Sweets'

Member of the Producer's Council

JOSAM MFG. CO., 304 Ferguson Bldg. Cleveland 14, Ohio

Send literature on Series G Oil Interceptors Series GN Oil Interceptors

NAME

FIRM

ADDRESS

CITY and STATE ZONE

TONCAN IRON

Lasts Longer in Actual Service

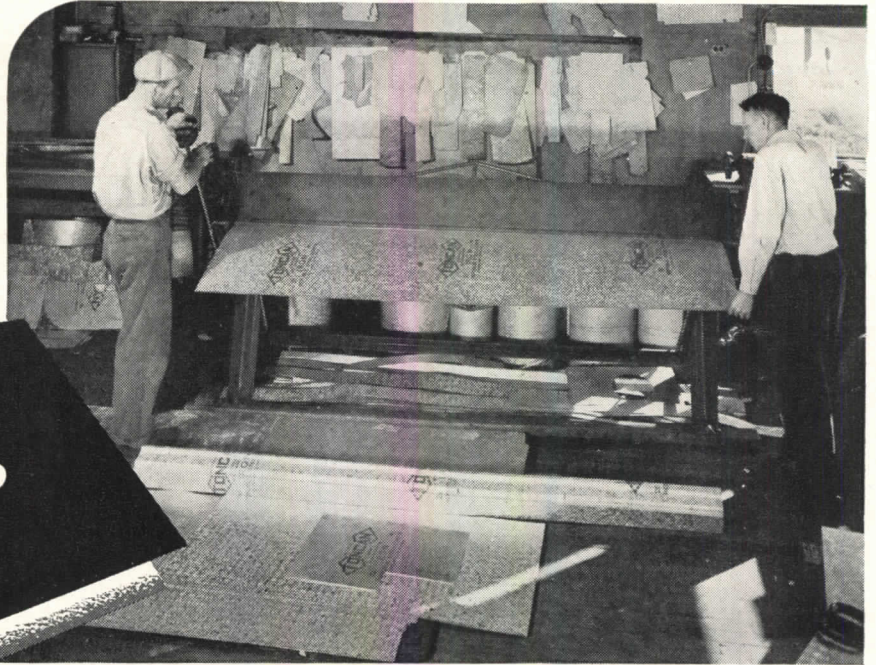

...because it
**RESISTS
RUST**

Ordinary rust offers no difficult problem to Toncan Iron, the long-lasting sheet metal that possesses *the highest rust-resistance of any ferrous material in its price class*. For nearly 40 years, this versatile iron has demonstrated its ability to last longer in countless types of installations, indoors and out.

Actually, Toncan Iron differs from ordinary irons—because it is an *alloyed* iron. It contains copper—twice as much as copper-bearing steel or iron—*plus* molybdenum, to intensify the effectiveness of the copper. Hence, its rust-resistance is not a surface quality, but extends uniformly throughout the metal—unaffected by bending, shearing, punching, corrugating, riveting and other cold working. Important, too, Toncan Iron welds readily.

Remember: The cheapest material always is that which costs less in the long run.

REPUBLIC STEEL CORPORATION
GENERAL OFFICES • CLEVELAND 1, OHIO
Export Department: Chrysler Building, New York 17, New York

See SWEET'S FILE
—or write us for detailed information on these Republic Steel Building Products:

- Pipe—Sheets—Roofing
- Enduro Stainless Steel
- Toncan Enameling Iron
- Electronite E.M.T.
- Fretz-Moon Rigid Steel Conduit
- Taylor Roofing Ternes
- Berger Lockers, Bins, Shelving
- Berger Cabinets for Kitchens
- Truscon Steel Windows, Doors
- Joists and other building products



Republic

TONCAN COPPER MOLYBDENUM IRON

REG. U. S. PAT. OFF.

—for ducts, gutters, conductor pipes, roofing, siding, tanks, ventilators, skylights, hoods and other sheet metal applications requiring rust-resistance—and for corrugated metal drainage products

serving the giant of industry

Leader

fluorescent luminaires

**LEADER
ZEPHYRLITE—ZUO-L-240-**
A light, easily installed industrial
unit. Corrugated for sturdy
strength, streamlined for smart
design. Built to eliminate the need
for installation "extras."

American industry, with its program of round-the-clock operations for top production, has turned to Leader for modern lighting techniques and new high standards of lighting performance. Wherever better industrial lighting is necessary, for critical detail work or for illuminating acres of machines and production lines, there is a scientifically designed Leader Fluorescent Fixture to fill each particular need. For better production through better lighting . . . Look to Leader.

Only better electrical wholesalers and contractors distribute and install Leader fixtures. There is a friendly Leader representative in your area.

LEADER ELECTRIC COMPANY
6127 NORTH BROADWAY • CHICAGO 40, ILLINOIS
WEST COAST FACTORY—2040 LIVINGSTON STREET, OAKLAND 6, CALIF.

A STEP AHEAD
LEADER
ELECTRIC COMPANY

Designed by
Ross-Frankel, Inc.

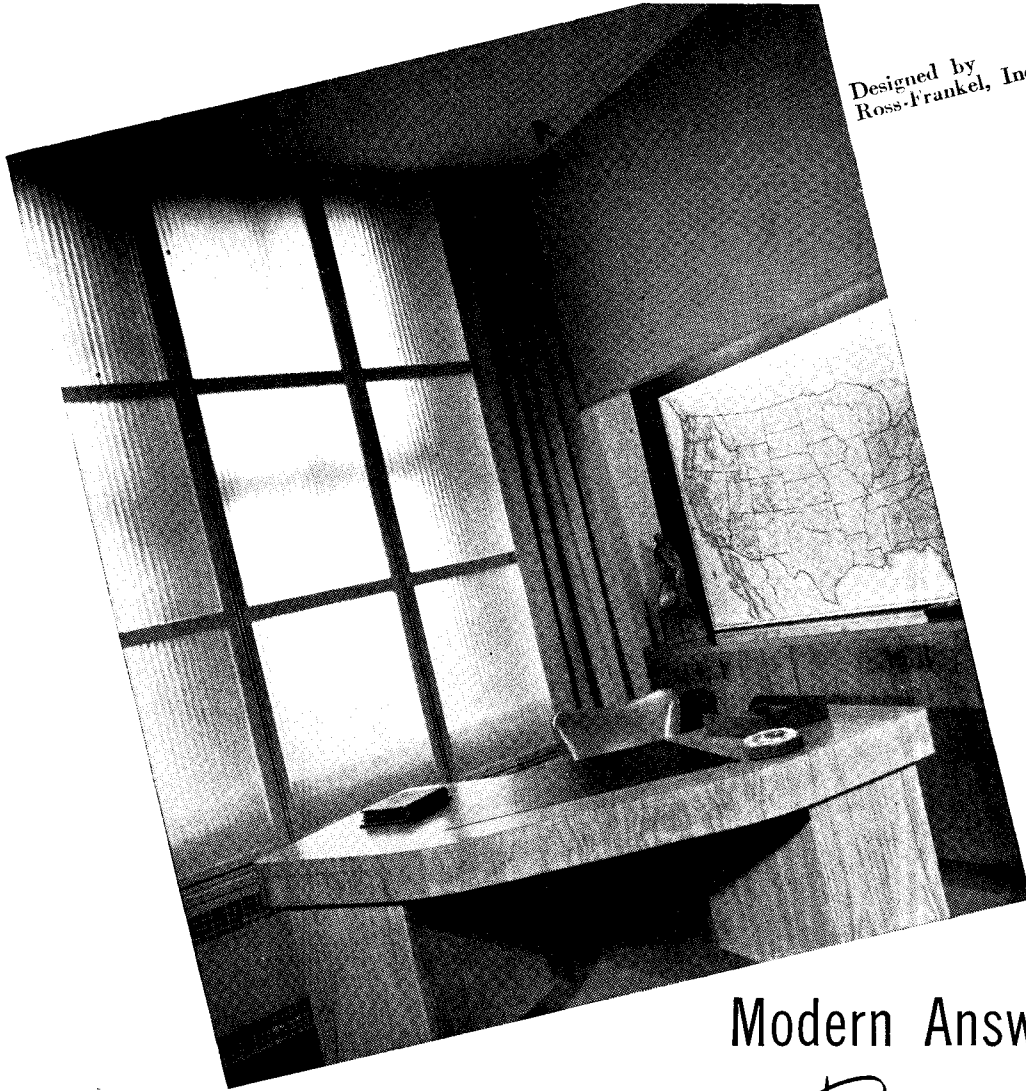

Modern Answer to Design Problems ... *Patterned Glass*

Where the view must be hidden, but daylight is essential, decorators and architects turn to *Patterned Glass* by Blue Ridge.

Clear or *Satinol*-finished, *Patterned Glass* gives free rein to the designer's imagination. Over 20 patterns offer wide choice in creating smart backgrounds, panels, screens and partitions in offices, homes, public buildings. Entire walls, as well as

windows, may be glazed with these modern glasses. They may be *Securitized* (heat-tempered) to withstand thermal and physical impact.

Consult your L·O·F Glass Distributor. Send for our *Patterned Glass Modernization Book* illustrated with photographs of actual installations. Blue Ridge Sales Division, Libbey-Owens-Ford Glass Co., 257 Nicholas Bldg., Toledo 3, Ohio.

FIVE POPULAR BLUE RIDGE PATTERNS

LOUVREX

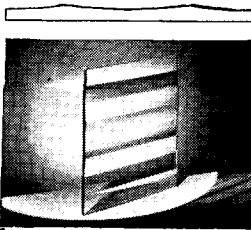

LINEX

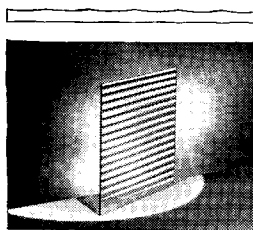

FLUTEX

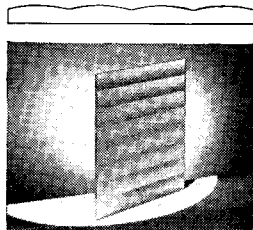

STYLEX

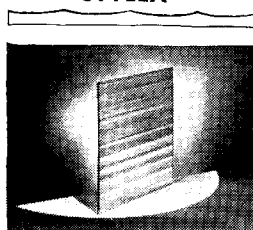

DOUBLEX

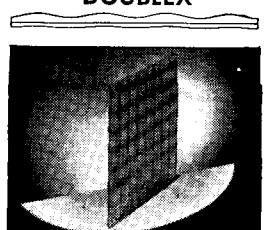

BLUE RIDGE *Patterned* GLASS

FOR SOFT, DIFFUSED LIGHT • SMART DECORATION • COMPLETE PRIVACY



When you build with concrete...

specify American Welded Wire Fabric reinforcement

• U.S.S. American Welded Wire Fabric fortifies the concrete slab against stresses and strains in all directions. Made of high yield point cold drawn steel wires, electrically welded, it is the most widely used fabricated reinforcement for concrete.

On every concrete construction job, no matter how large or how small, there is a place where the use of American Welded Wire Fabric will effect worthwhile economies.

When you build with concrete, specify American Fabric. It is made by the world's largest manufacturer of prefabricated reinforcing materials.

American Steel & Wire Company
Cleveland, Chicago and New York

Columbia Steel Company, San Francisco
Pacific Coast Distributors

Tennessee Coal, Iron & Railroad Company, Birmingham
Southern Distributors

United States Steel Export Company, New York

UNITED STATES STEEL

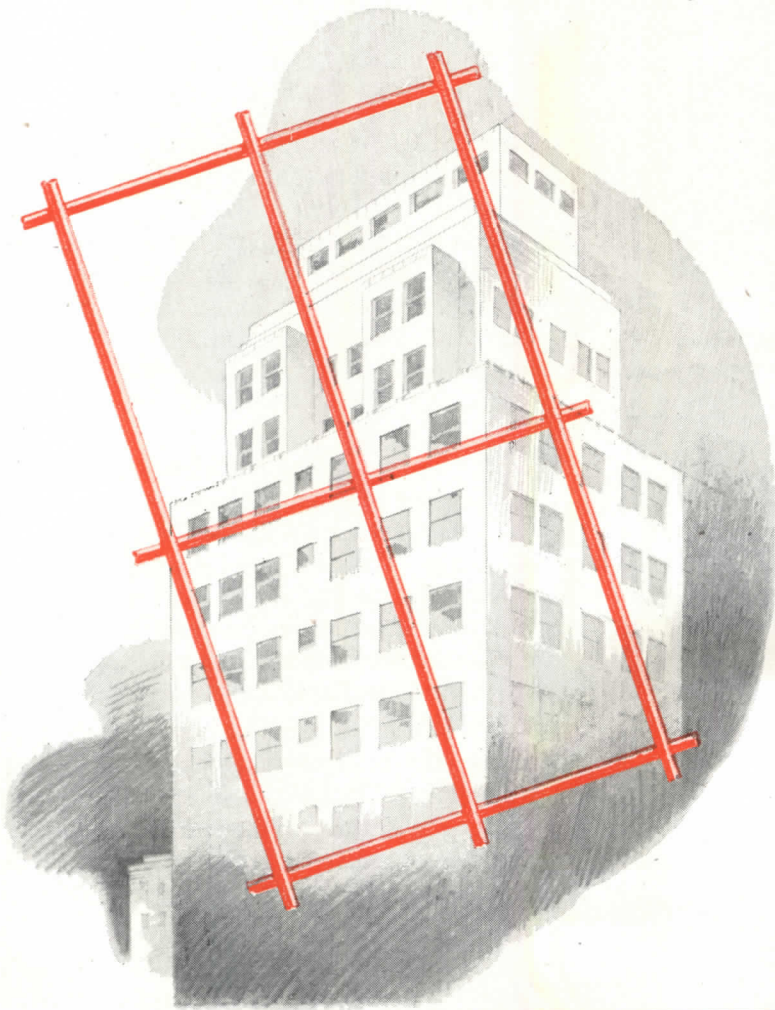

Every type of concrete construction needs **American Welded Wire Fabric** reinforcement.

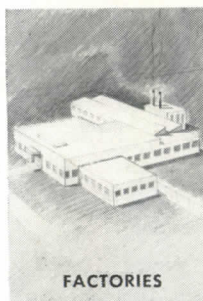

FACTORIES

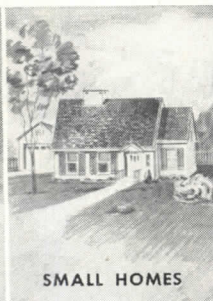

SMALL HOMES

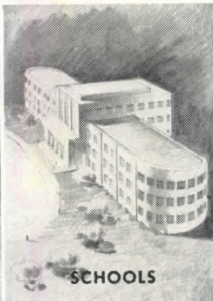

SCHOOLS

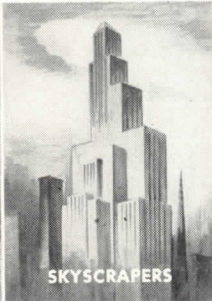

SKYSCRAPERS

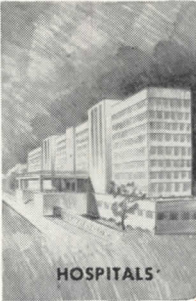

HOSPITALS

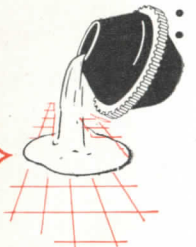

Time-tested welded construction

... keynotes strength — safety



Murdock Hall
Nurses Residence



Margaret Hague Maternity
Hospital Annex

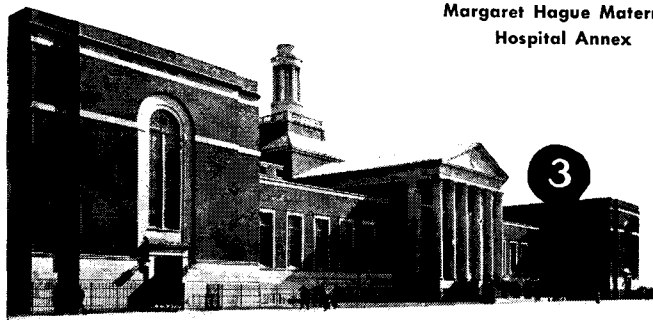

Benjamin Franklin
High School

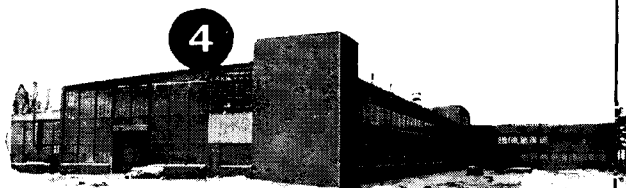

Mechanical Research
Laboratory

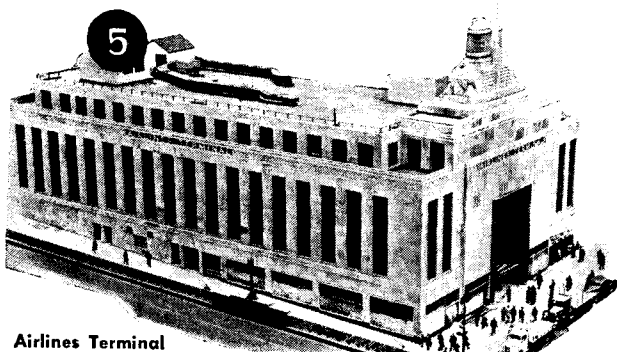

Airlines Terminal

Here are five more reasons why welded construction is winning increasing acceptance by architects and builders — everywhere. In these typical structures, this modern process shows its ability to “take it” under all conditions . . . definitely proving that welded construction affords unquestionable strength and enduring safety — *a welded joint is actually stronger than the base metal.*

This is just one of the many outstanding advantages of economical welded construction. For further details, write for “Manual of Design for Arc Welded Steel Structures” — a handy, useful book that brings you a wealth of information covering design, materials, estimating, and engineering control of welding and related operations.

But see this invaluable manual for yourself — just mail us your check for \$2, and we will send the book to you . . . look it over for ten days; then, at the end of this period, if it does not live up to your expectations, simply return the book to us, and we will refund your money.

Write today; address: Dept. AR 6240, Air Reduction, 60 East 42nd St., New York 17, N. Y. In Texas: Magnolia Airco Gas Products Co., Houston 1, Texas.



AIR REDUCTION

Offices in All Principal Cities

Headquarters for Oxygen, Acetylene and other Gases . . . Carbide . . . Gas Welding and Cutting Apparatus and Supplies . . . Arc Welders, Electrodes and Accessories

STEEL DECK



WELDED STEEL SUMP RECESSES

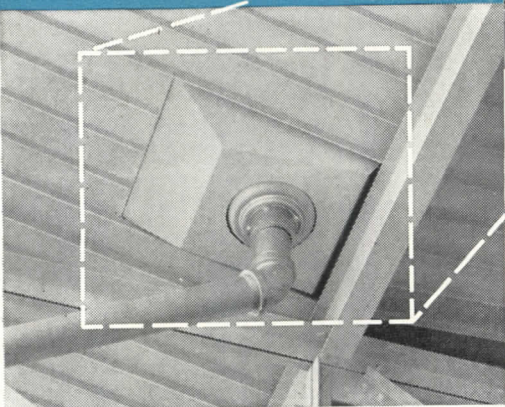

Typical Installation of Mahon Welded Steel Sump Recess. These can be furnished to fit any Roof Pitch specified.

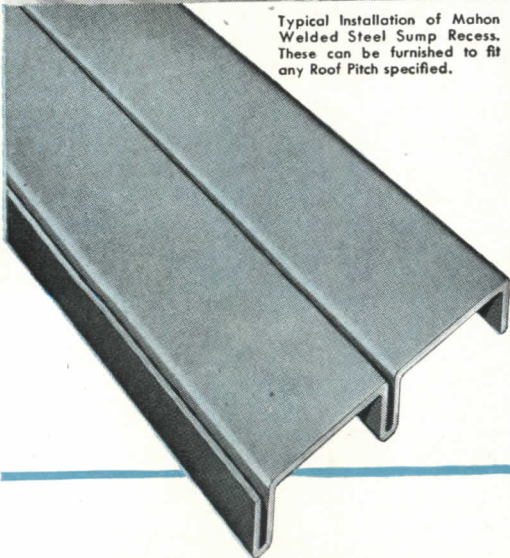

Standard Mahon Double Rib Steel Deck Plate. Single Rib Plates are also Available for Sidewalls and Partitions which may be insulated to Any Degree Against Heat, Cold or Noise.

Note the angle of the third and fourth purlins in the illustration above. These have been set to create a drainage valley at the sump location.

for ROOFS, SIDEWALLS and
CEILINGS . . . PARTITIONS
and CONCRETE FLOOR FORMS

Every day alert designers and builders are finding Steel Deck ideally suitable for more and more uses in building construction . . . roofs, sidewalls, partitions, floors, and many other applications in the industrial, commercial and residential field. Mahon Steel Deck, due to its basic design with narrow, vertical-leg stiffening ribs, lends itself to a broader range of uses in modern construction. See Mahon Insert in Sweet's File for complete information, specifications, and latest construction details, or consult a Mahon representative.

THE R. C. MAHON COMPANY

Home Office and Plant, Detroit 11, Mich. • Western Sales Division, Chicago 4, Illinois

Representatives in all Principal Cities

Manufacturers of Steel Deck for Roofs, Sidewalls, Ceilings, Floors, Partitions and Doors. Also Roof Sumps and Recesses, Rolling Steel Doors, Grilles, and Underwriters' Labeled Rolling Steel Doors and Fire Shutters.

MAHON

A NEW CLIMATE FOR HOUSING

EDITOR:

The article in your February number on Rental Housing calls for a favorable "climate for housing" and presents seven "Suggestions for Stimulating Rental Housing."

It may be advisable to adopt some of these measures, but in my opinion, no one of them nor all of them together can produce a "climate" in which we can develop a rational answer to our needs.

1. *Remove all rental ceilings from newly constructed rental housing.* Since existing controls have failed to actuate much rental housing, this would seem to be a logical step. At least some high rental units may result, of which a limited number are needed. But this will do nothing to supply the need for medium and low rental housing, which is the big market. We know from past experience that overbuilding for high incomes, trusting to a subsequent bust to bring prices down, doesn't work. Where do the G.I.'s and other young married people come into this process? They need homes now, not at the end of an economic cycle of boom and bust. We can't rely on the "trickle down" process. How many high rental units can we build before the market is glutted, with the consequent cessation of building? A rental of \$100 a month requires an income of approximately \$5000. Suppose that as many as 10 per cent of the families in this country enjoyed such an income, and that as much as 60 per cent of the needed annual supply of 1,200,000 dwellings were in rental units. This would mean on a prorated basis 72,000 high rental units for the entire nation. But since high income families are generally adequately housed, the number needed is doubtless considerably less — say 50,000. Where does the veteran come out in this deal? Are his frequent complaints that the promises made him are not being kept at all surprising?

2. *Remove all government cost restrictions on new rental units.* Perhaps this will produce some housing, but, for the reasons mentioned above, it will necessarily be a small quantity.

3. *Adjust rents on existing dwellings.* This may be necessary in some instances where hardships are worked on landlords by present controls, but only where such *hardship* is proven.

Rental ceilings on existing buildings are necessary and fair since their cost is a thing of the past. Existing buildings far outnumber any that could possibly be built now, and ceilings on their rentals are our main protection against a runaway inflation in rents.

4. *Remove or modify the federal corporate income tax on rental housing corpora-*

tions. In their excellent study, Messrs. Paul and Colean show clearly the adverse effect that this tax can have on the security of a real estate corporation. It would appear that at least a modification of the tax is in order. It is difficult to estimate quantitatively the result of such modification.

5. *Remove all restrictions on the building of single-family homes.* This will not help to produce the \$5000 house. There is already buyer resistance to paying \$10,000 and up for a home that should cost half those amounts. Those who in desperation buy them to have a roof over their heads are the victims who will take a beating when prices drop.

6. *Remove restrictions on non-residential buildings.* If it is a fact that materials on hand are sufficient for all types of construction, this is obviously the proper thing to do. It is not as yet entirely evident that the needs of residential construction are being adequately supplied, and home building is an emergency need that should come first. It is not clear to me how this proposal would help housing, inasmuch as it would place other claims on a parity with housing demand in competition for the more scarce materials.

7. *Enable insurance companies to undertake equity ownership in states not now permitting it.* Few will question the wisdom of this proposal. There is some question how much immediate good it will do. The insurance companies are real investors, not shoe-string operators. They are not tempted to build at present prices, for they are faced with what is tantamount to a capital loss at such future time as prices recede and others will be able to base their rentals on lower costs than those which prevail today.

At a time when prices are so high that no real investor will risk his money in a rental project, it is futile to revert to the mechanisms of real estate anarchy which never have worked and can't do so now. A new climate for housing is not to be achieved suddenly or by purely negative methods. It requires a new approach to the entire problem of housing and the slaughter of many sacred cows. Here are some of the things I think we must do to create that climate:

(a) Recognize the fact that housing is a primary need, requiring a program that is complete, continuous and coordinated. We must rid ourselves of the notion that housing can possibly be an automatic by-product of private profit. The process of producing houses means wages for workers and profits for contractors, and it should. But it is a far cry from this to the assumption that wages and profits can be the mainspring of

housing production. One of the primary troubles today is the fact that government aid to housing has been based largely on this fallacy.

(b) Discourage the use of housing as a mere trading commodity and encourage genuine investment by those who seek a moderate but reasonably assured profit. Abolish shoe-string equities and the consequently unsound financing. Whether a man invests for profit or for home ownership, he should have a sizeable equity, in the interest of decent construction, proper maintenance and as a safeguard against default. In its efforts to produce more housing, the Federal Housing Administration has relied mainly on the thinning down of the equity requirements, supplemented during the emergency by waivers of physical standards. Before long this may be calamitous to the home owners who have been saddled with an excessive debt in exchange for a tenuous hold on a structure of questionable quality.

(c) Adopt a more realistic approach to the problem of home ownership. Both the government and the lending institutions have been remiss in their obligation to tell prospective home owners just what is involved in their purchase of a home with a heavy debt. The government has never adequately protected the home owner against excessive interest, loss of his home through temporary inability to meet a single payment of charges and against deficiency judgments.

(d) Develop a housing industry, operating on a large scale, adequately financed and doing a complete job of housing production. This could reduce measurably the first cost of the product and consequently greatly widen the market of potential buyers or renters.

(e) Clarify the role of public agencies in the housing picture. In addition to what housing they may assist, they should continuously investigate the need for all types of housing and develop a program for the production of all that is needed, whether privately or publicly initiated.

(f) Since housing is an essential need, we should not hesitate to resort to subsidy when and where it is required to produce the goods. In some cases this may mean subsidies to private developers, with a *quid pro quo* of lower sales prices or rentals. But if we do resort to subsidy, let it be open and avowed and not obscured by phoney financial legerdemain.

Every one of these proposals requires a break with past attitudes and practices. It is not an easy job. It will take time, patience and courage, but it would tend to create a truly healthy climate for housing.

— EUGENE H. KLABER, F.A.I.A.
Housing and Town Planning Consultant

ATLAS LABOR-*SAVING* *SPEED* FORMS



House foundations with dividing wall.
General Construction Co.,
Contractors, Columbus, Ohio

Builders pour a foundation like this in a day.

The STEEL FORMS That *SPEED UP* CONCRETE CONSTRUCTION

Builders and engineers make savings of 25 to 50%, and do a better job in less time with Atlas Speed Forms—Much better and faster than with plywood.

Easily and speedily erected, stripped and moved. No studs or joists needed. Light-weight—anyone can handle them. Ruggedly built of steel—good for indefinite use without repair. *Form Cost per sq. ft. per use less than one cent.*

FOR SALE OR RENT

Complete layout and erection supervisory service to new users. Let us show you how much time and money you can save with Atlas Speed Forms.

Write for Facts and Prices

Irvington Form & Tank Corp.

IRVINGTON 24, N. Y.

Write Dept. A

New York Office: 43 Cedar St. Tel. BOWling Green 9-4030

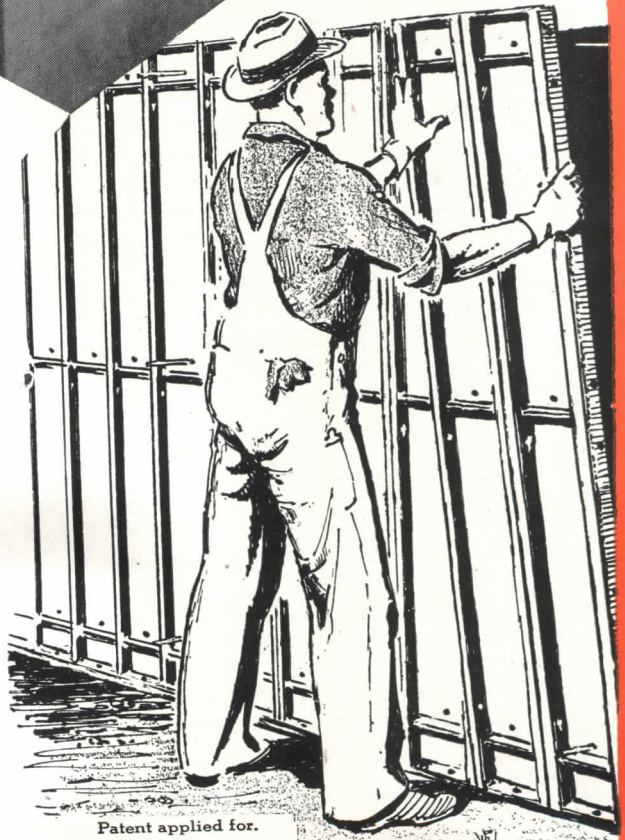

Patent applied for.

Atlas *SPEED* forms line up straight and true. • Easy to set up, move and strip • Adjustable to suit any condition • Interchangeable—can be used for walls or floors —Smooth Finish—no knot or grain marks —Nothing to remove.

Atlas Steel Forms for every Purpose

CONSTRUCTION COST INDEXES — Labor and Materials

United States average 1926—1929=100

Compiled by Clyde Shute, manager, Statistical and Research Division, F. W. Dodge Corporation, from data collected by E. H. Boeckh & Associates, Inc.

NEW YORK

ATLANTA

Period	Residential		Apts., Hotels, Office Bldgs. Brick and Concr.	Commercial and Factory Buildings		Residential		Apts., Hotels, Office Bldgs. Brick and Concr.	Commercial and Factory Buildings	
	Brick	Frame		Brick and Concr.	Brick and Steel	Brick	Frame		Brick and Concr.	Brick and Concr.
1920	136.1	136.9	123.3	123.6	122.6	122.8	122.9	108.6	109.8	105.7
1925	121.5	122.8	111.4	113.3	110.3	86.4	85.0	88.6	92.5	83.4
1930	127.0	126.7	124.1	128.0	123.6	82.1	80.9	84.5	86.1	83.6
1935	93.8	91.3	104.7	108.5	105.5	72.3	67.9	84.0	87.1	85.1
1939	123.5	122.4	130.7	133.4	130.1	86.3	83.1	95.1	97.4	94.7
1940	126.3	125.1	132.2	135.1	131.4	91.0	89.0	96.9	98.5	97.5
1941	134.5	135.1	135.1	137.2	134.5	97.5	96.1	99.9	101.4	100.8
1942	139.1	140.7	137.9	139.3	137.1	102.8	102.5	104.4	104.9	105.1
1943	142.5	144.5	140.2	141.7	139.0	109.2	109.8	108.5	108.1	108.7
1944	153.1	154.3	149.6	152.6	149.6	123.2	124.5	117.3	117.2	118.2
1945	160.5	161.7	156.3	158.0	155.4	132.1	133.9	123.2	122.8	123.3
1946	181.8	182.4	177.2	179.0	174.8	148.1	149.2	136.8	136.4	135.1
Jan. 1947	195.4	198.0	183.9	186.2	183.0	161.9	164.2	145.7	147.1	145.8
Feb. 1947	204.7	208.9	194.7	193.5	191.1	165.8	166.8	148.8	149.9	148.8
	% increase over 1939					% increase over 1939				
Feb. 1947	65.8	70.6	48.9	45.0	46.8	92.2	100.7	56.5	53.9	57.1
	ST. LOUIS					SAN FRANCISCO				
1920	118.1	121.1	112.1	110.7	113.1	108.8	107.5	115.2	115.1	122.1
1925	118.6	118.4	116.3	118.1	114.4	91.0	86.5	99.5	102.1	98.0
1930	108.9	108.3	112.4	115.3	111.3	90.8	86.8	100.4	104.9	100.4
1935	95.1	90.1	104.1	108.3	105.4	89.5	84.5	96.4	103.7	99.7
1939	110.2	107.0	118.7	119.8	119.0	105.6	99.3	117.4	121.9	116.5
1940	112.6	110.1	119.3	120.3	119.4	106.4	101.2	116.3	120.1	115.5
1941	118.8	118.0	121.2	121.7	122.2	116.3	112.9	120.5	123.4	124.3
1942	124.5	123.3	126.9	128.6	126.9	123.6	120.1	127.5	129.3	130.8
1943	128.2	126.4	131.2	133.3	130.3	131.3	127.7	133.2	136.6	136.3
1944	138.4	138.4	135.7	136.7	136.6	139.4	137.1	139.4	142.0	142.4
1945	152.8	152.3	146.2	148.5	145.6	146.2	144.3	144.5	146.8	147.9
1946	167.1	167.4	159.1	161.1	158.1	159.7	157.5	157.9	159.3	160.0
Jan. 1947	183.4	183.8	168.5	169.3	169.5	173.2	170.8	167.3	169.4	172.5
Feb. 1947	187.6	187.0	173.9	175.2	172.8	177.0	173.9	172.4	174.6	176.1
	% increase over 1939					% increase over 1939				
Feb. 1947	70.1	74.8	46.5	46.2	45.1	67.6	75.2	46.8	43.3	51.1

The index numbers shown are for combined material and labor costs. The indexes for each separate type of construction relate to the United States average for 1926-29 for that particular type — considered 100.

Cost comparisons, as percentage differences for any particular type of construction, are possible between localities, or periods of time within the same city, by dividing the difference between the two index numbers by one of them; i.e.:

index for city A = 110

index for city B = 95

(both indexes must be for the same type of construction).

Then: costs in A are approximately 16 per cent higher than in B.

$$\frac{110-95}{95} = 0.158$$

Conversely: costs in B are approximately 14 per cent lower than in A.

$$\frac{110-95}{110} = 0.136$$

Cost comparisons cannot be made between different types of construction because the index numbers for each type relate to a different U. S. average for 1926-29.

Material prices and wage rates used in the current indexes make no allowance for payments in excess of published legal prices, thus, indexes reflect minimum costs and not necessarily actual costs.

These index numbers will appear whenever changes are significant.

UNITED STATES RUBBER COMPANY

SERVING THROUGH SCIENCE

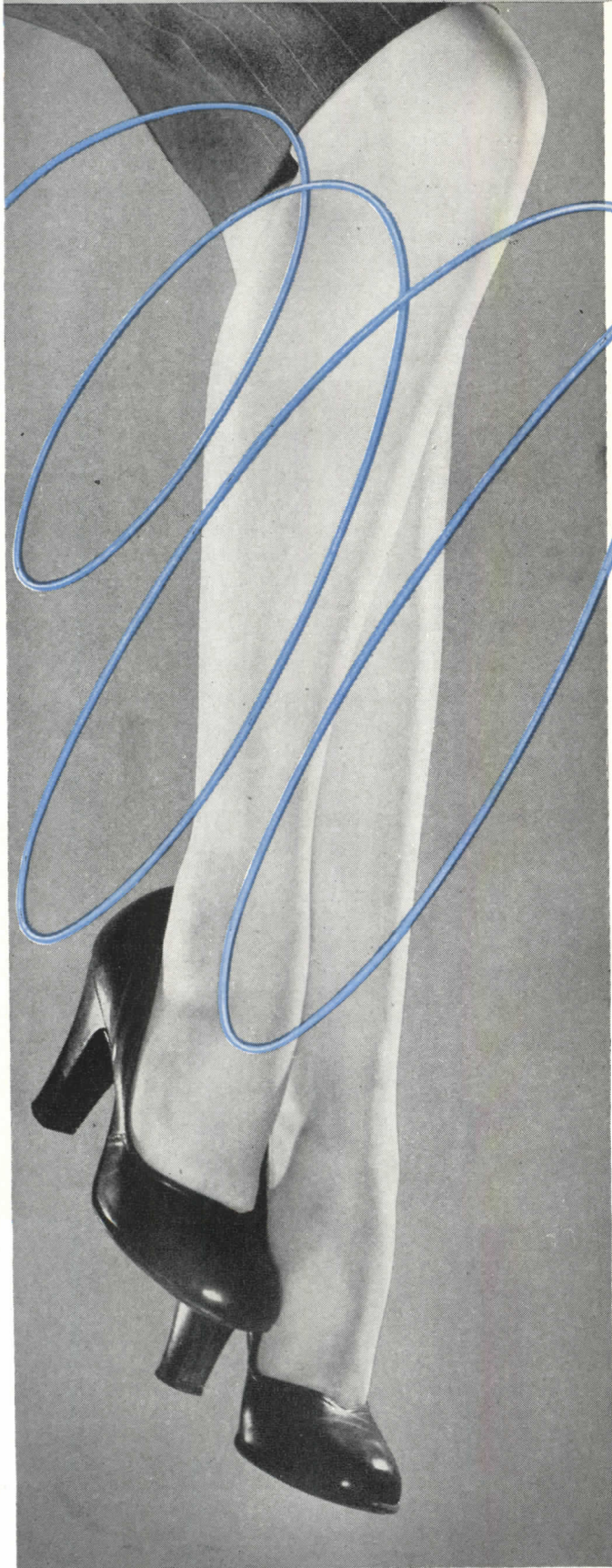

*a modern
new wire*

This new building wire, in the branch circuit sizes, is finished in nylon and is called "Neolay."

It's the smallest diameter, lightest weight building wire on the market. The nylon-smooth finish and small diameter facilitate installation.

Laminated walls of Laytex (90 per cent pure rubber) insulation give high dielectric strength. On top of the Laytex is a layer of flame retardant Neoprene.

The larger sizes—No. 6 AWG to 1,000,000 CM—are supplied with an aluminum conductor, RH insulation and a Neoprene jacket. This construction provides a cable that is unusually tough and strong, and exceedingly light.

Investigate! Write United States Rubber Company, Wire and Cable Department, 1230 Avenue of the Americas, New York 20, N. Y.

Neolay

Reg. U. S. Pat. Off.

ELECTRICAL WIRES & CABLES



REQUIRED READING



Insertion of insulated wall panels in a prefab. From "The Prefabricated House"

PREFABS FOR EVERYONE

The Prefabricated House: A Practical Guide for the Prospective Buyer. By Raymond K. Graff, Rudolph A. Matern and Henry Lionel Williams. Garden City, N. Y., Doubleday & Co., Inc., 1947. 6½ by 9¾ in. Illus. \$2.75.

A good bit of the confusion still existing in the average lay mind about the prefabricated house will be cleared up by this book. Written by a pair of architects and an old-hand author, it is as concise and clear as the complicated subject will permit.

"The first thing to remember," the authors state right at the beginning, "is that in buying any prefabricated house you do not get a complete dwelling ready for occupation, and that the package may actually represent less than 50 per cent of the cost of the finished job." Well, what do you get in your "package"? That depends on the manufacturer: maybe you'll get painting and plastering, maybe you won't; the carpenter work may be almost complete, or a great deal of it may have to be done on the site. All you can do is investigate carefully what each manufacturer offers, and choose the house that best suits your needs.

To the average layman that is going to be a pretty discouraging discovery. The discouragement, however, will be quickly outweighed by the thoroughness of the ensuing discussion. The prospective purchaser of a prefab will be spared many a headache if he reads this book. He will learn what to look for, what to expect, what his maintenance problems may be, how to select and adapt the site, how exactly to go about buying a prefab, and finally who and where the manufacturers are. He will also get a pretty good idea of what his house may look like both outside and in. He will even get a general idea of its construction. In short, he will not be buying a pig in a poke, but, if he reads these pages care-

fully, a house which should more or less come up to his expectations.

ARCHITECTURE OF OLD

An Album of Maya Architecture. By Tatiana Proskouriakoff. Washington 5, D. C. (1530 P St., N.W.), Carnegie Institute of Washington, 1946. 15¼ by 12 in. 150 pp. 36 plates. \$10.00.

Through the years a great many books and articles dealing with Maya architecture have appeared, but none has been more interesting pictorially than this. Miss Proskouriakoff's full-page drawings have captured the spirit not only of the buildings themselves but of the civilization which produced them.

This volume is well named an album despite the page or so of text accompanying each plate. The text is wholly unobtrusive, held to a minimum and used only to point up the illustrations. There is, however, a good introduction presenting the more salient facts about Maya civilization. Enough information is given to make it possible for the reader who is unfamiliar with the Maya to understand and appreciate the perspectives.

The 36 plates include such well-known buildings as the Acropolis at Piedras Negras, Guatemala, and the various excavations at Chichen Itzá, Yucatan, as well as less familiar structures such as the Maya sweat bath at Piedras Negras, the ball court and the reviewing stand at Copan, Honduras.

This is a beautiful book. It has been prepared with the greatest care, and shows it in the excellent typography and printing. The plates are well arranged, and there is a frontispiece map locating the various sites.

THE FUTURE IS OURS

Land of Plenty: A Summary of Possibilities. By Walter Dorwin Teague. New York 17 (383 Madison Ave.), Harcourt, Brace and Co., 1947. 5¼ by 8 in. 320 pp. \$3.00.

This book, says its author, "is an effort to convey some idea of what we can make of life in this country if we have sense enough to use the scientific, technological, and productive resources now at our command."

Mr. Teague is fully aware of all the problems that must be solved before the goal he is reaching for can be achieved. He delves into the economic depressions that have hit us. He takes a frank look at the government. He explores the increasingly difficult labor situation. Discouraging as the record is, his faith in the future is unbounded as he summarizes the tremendous strides taken by science and industry since the turn of the century.

The titles of the several chapters on housing are indicative of his attitude:

"We Can Provide Millions of Houses," "And Furnish Them Decently," "In Gracious Communities." Production and distribution of housing, Mr. Teague says, are out of line with production and distribution of less essential items such as the automobile. Houses cost too much to build and are too hard to buy — "contrast the elaborate and fearsome mortgage rigmarole, itself a survival of a handicraft age, with the simple installment-plan purchase of an automobile." For the families who can afford them, the traditionally built houses tailored to specific needs and tastes are fine. But something must be done for the larger number of families whose incomes just cannot permit such handicraft building. "What our vast, shifting, wage-earning population needs if it is to be well housed is a bright, shining, handsome, completely equipped, up-to-date machine for living, costing between \$1000 and \$2500; a house a man can alter or enlarge by buying spare parts; a sturdy but light-weight house he can disassemble and take with him, if he wants to, when he shifts his job, and turn in on a new model in ten or a dozen years when it becomes obsolete; a house he can buy on the installment plan and pay for in two or three years without a lot of red tape." In other words, prefabrication and mass production keyed to their peak of efficiency, Mr. Teague feels, will provide the answer to the housing problem. Technologically and economically, he says, we are ready for it.

As there would have to be in a book of this kind, there is a good bit of discussion of the labor situation. Mr. Teague is an industrial designer, not a factory owner, but his arguments on the whole are sound. He stresses the necessity for everyone's pulling together. He sees no reason why labor and capital cannot split their differences and come to an understanding which will be of mutual benefit. He offers as a possible solution, the not very widely known Keuls-Kenyon Plan, which puts forward a uniform, guaranteed minimum wage for everyone and a plan for labor's profit-sharing.

HOW MUCH HOUSING?

Estimating Housing Needs. By Alexander Block. London S.W. 1, Eng. (13 Queen Anne's Gate), The Architectural Press, 1946. 5½ by 8½ in. xiv. + 128 pp. illus. 10s 6d.

The question of how much housing and what kind a country may need is never an easy one to answer. Even when a housing census has been taken and the results have been compiled, the exact needs are not known. A super-soothsayer must be called in to predict probable increases and changes in population in the years just ahead. It is to help make this prognostication more scientific and less mediumistic that this study has been

(Continued on page 30)

*A Challenging New Design Form
for Low-Cost Homes!*

STRAN-STEEL ARCH-RIB HOMES

ELIGIBLE STRUCTURALLY FOR FHA MORTGAGE INSURANCE

NOW YOU CAN DESIGN
HOMES IN THE \$4,000-
\$6,000 PRICE RANGE
THAT ARE SUPERIOR
STRUCTURALLY AND
AESTHETICALLY . . .
AND THAT CAN BE BUILT

NOW!

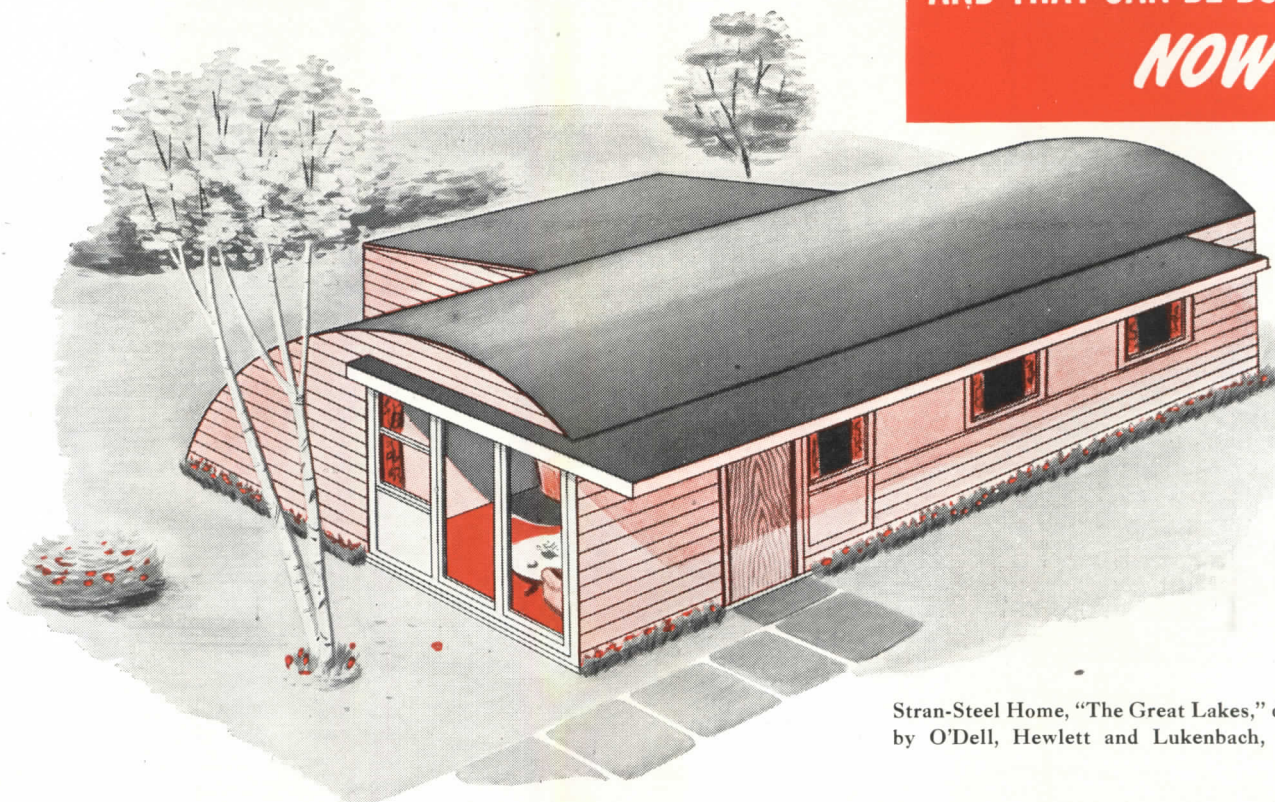

Stran-Steel Home, "The Great Lakes," designed by O'Dell, Hewlett and Lukenbach, Detroit.

This really significant development in low-cost housing brings you new opportunities to design modern, functional homes that meet every requirement of the greatest home market in history! Inspired by the clean lines and the arresting sweep of the arch, you will find it easy to blend beauty and utility in Stran-Steel Homes.

Stran-Steel Homes owe their low cost, their strength, permanency and functional simplicity to Stran-Steel arch-rib framing and exterior steel sheathing. Local labor and collateral materials are employed to achieve almost unlimited variations in design — in exteriors and floor plans.

Stran-Steel arch-rib framing provides greater ease and speed of erection, greater strength and durability, greater resistance to fire, elimination of warping, rotting and termite damage. And its patented nailing groove permits collateral materials to be nailed securely and permanently to the all-steel frame.

No alert architect can afford to remain uninformed about this great new development. Ask your local Quonset dealer to show you the complete designs already made, as well as site plans for communities of 25, 100 and 1,000 homes developed by Seward H. Mott. Or write direct, if you prefer.

GREAT LAKES STEEL CORPORATION

Stran-Steel Division • Dept. 36 • Penobscot Building • Detroit 26, Michigan
UNIT OF NATIONAL STEEL CORPORATION





HI-DENSITY

For Line-Opacity matched to the modern Tracing Papers... and to the reproduction possibilities of Modern Print Making!

Try it! Compare! Words cannot make the difference between the new and the old in drawing pencils half as real as your own experience. Lines do print with sharper definition. There is a noticeable absence of fuzziness. And there is a greater freedom from smudging... Whatever your past preference, you owe it to yourself to try something better. Clip the coupon and see for yourself.

MICROTOMIC VAN DYKE
THE EBERHARD FABER DRAWING PENCIL

EBERHARD FABER
Brooklyn 22, New York

37 Greenpoint Avenue, Dept. AR-5
If you'll send me a _____ degree sample FREE, I'll test-prove your claims for HI-DENSITY lead's superiority.

Name _____
Firm _____
Street & No. _____
City & State _____

REQUIRED READING

(Continued from page 28)

prepared. Its whole approach to the problem, therefore, is scientific.

Mr. Block does not offer a new type of census as the solution, but suggests more accurate methods of interpreting the information already available. He puts considerable stress on the ways and means of ascertaining the approximate number of one-person "families" to be housed. He proposes certain changes in terminology which would help to clarify census results. And above all, he shows why previous housing estimates have gone astray. This book should be of considerable help to town planners as well as to housing authorities, particularly when it is joined, as it is soon to be, by further studies by the same author.

WHAT ARCHITECTS DO

Notes on Architectural Practice. By C. H. Cowgill. Blacksburg, Va., The College Book Store, 1947. 8½ by 11 in. 186 pp. Mult. \$3.00 (\$2.70 ea. in quantities of 20).

Addressed to architectural students, these notes on the workings of the profession are characterized primarily by frankness. From the very first page on how to snare a job the problems are discussed with complete candor. The author's statements are not presented as gospel, but are intended to give the overall picture and to stimulate the reader to thoughts of his own.

The notes originated as lectures given at Virginia Polytechnic Institute; they were used as a textbook during the war years, apparently with considerable success. Prof. Cowgill, head of the Department of Architecture at V.P.I., has assembled his material in most logical fashion, working straight through from the securing of a commission, client relationships and preliminary sketches to such intricate matters as contracts and the financing of projects. The thoroughness of his coverage is indicated by the chapter on preliminary sketches and models: included are suggestions as to the media used for such sketches and a good bit of detail on the making of models. In the chapter on working drawings there is again a discussion of the techniques most commonly used, and an explanation of the choice of scale.

Unusual chapters in a book of this kind are those dealing with the business end of the profession — Architects' Capital, Business Fundamentals, The Profit and Loss System, and so on. A whole section is devoted to these matters, and another to the legal and professional aspects. Examples and diagrams are used liberally throughout the text for maximum clarity. Reading lists, problems and review questions are given for each chapter.

PLAN FOR LOWER COSTS WITH

PC GLASS BLOCKS

(A Modular Product)

► One way to help your clients combat rising production costs is to take full advantage of the economies inherent in the modern building material of countless uses, PC Glass Blocks.

Light—plenty of it—is directed to where it is needed most. So, much of the money they would otherwise pay out for artificial light is saved.

Panels of PC Glass Blocks are quickly and easily cleaned, inside and out. They prevent dust infiltration, rarely need repairs or replacement. So they save time and the cost of maintenance labor and supplies.

In addition, PC Glass Block panels have high insulating efficiency. So heat losses are materially reduced, thereby reducing wear and tear on heating and air-conditioning equipment and saving many of the dollars that would otherwise be spent for fuel.

These are some of the ways PC Glass Blocks pay for themselves in commercial and public buildings over a period of years. And remember that they are made in six, eight and twelve inch sizes, all of which are suitable for *modular coordination*, which means important additional savings, in planning and construction, for you and for your clients.

Why not fill in and mail the convenient coupon for a free copy of our booklet, which contains *complete* information on this modern building material? Pittsburgh Corning Corporation, 632 Duquesne Way, Pittsburgh 22, Pa.

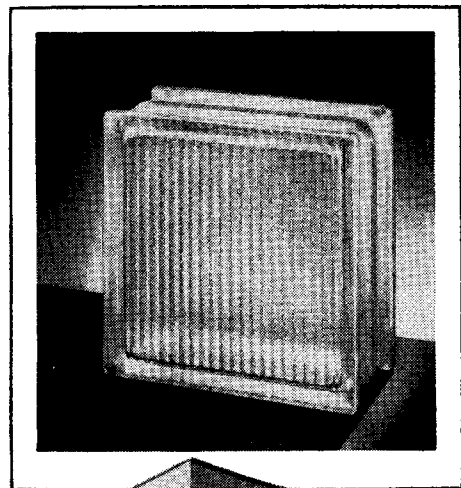

Also Makers of
PC Foamglas Insulation

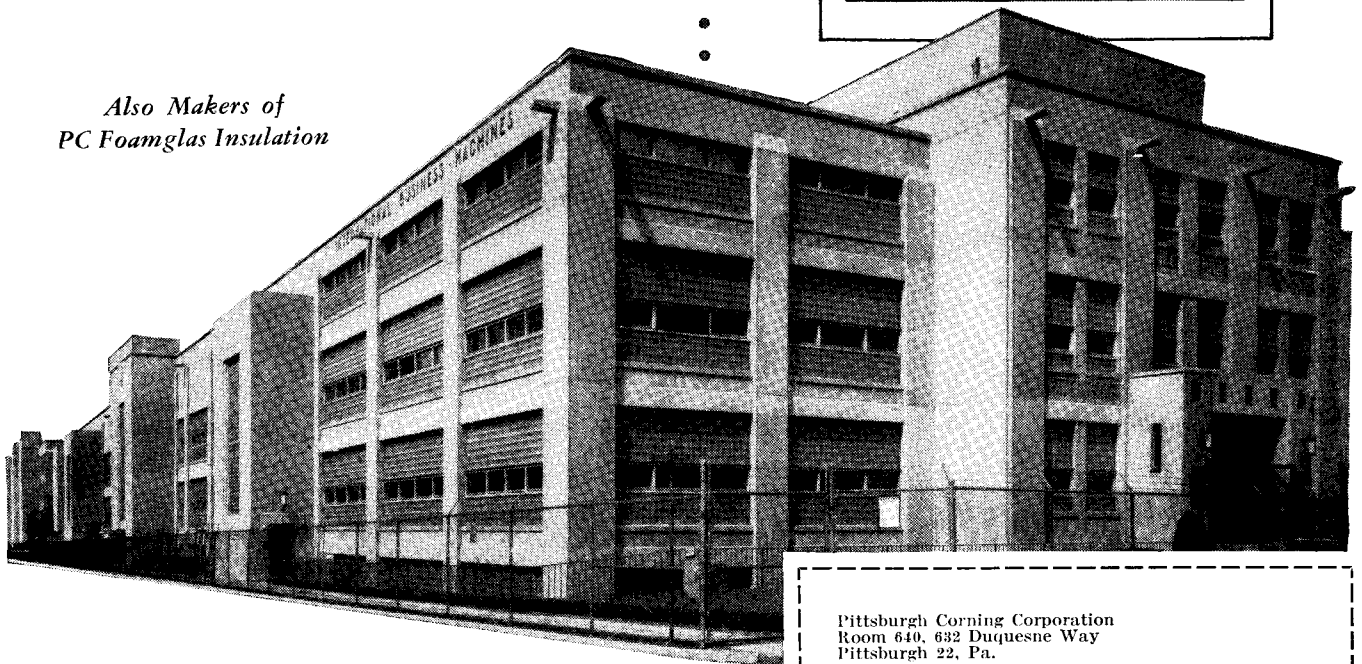

FOR ADDITIONAL INFORMATION SEE OUR INSERTS IN SWEET'S CATALOGS

GLASS BLOCKS

Distributed by PITTSBURGH PLATE GLASS COMPANY
by W. P. Fuller & Co. on the Pacific Coast and
by Hobbs Glass Ltd. in Canada

Pittsburgh Corning Corporation
Room 640, 632 Duquesne Way
Pittsburgh 22, Pa.

Please send along my free copy of your new book on the use of PC Glass Blocks for Commercial and Public Buildings. It is understood that I incur no obligation.

Name.....

Address.....

City..... State.....

SELECTION OF RESILIENT FLOORS FOR SCHOOLS

While the flooring requirements for all types of buildings have much in common, there are important differences to be considered by the architect in planning certain building types. In school buildings, for example, there are a number of areas for which the flooring should be selected to meet special service requirements. In addition, the relative importance of costs, appearance, and durability must be determined in each case by the architect. The following information may be helpful to him in judging the merits of the different types of flooring for school use.

Lobby, Corridor, and Study Hall

The heaviest traffic must be carried by floors in the lobby, corridors, and study halls. These areas, therefore, require floors of great durability which are easily maintained. Appearance is also another important factor. Recommendations for these floors include Linotile, linoleum, rubber tile, and asphalt tile. Linotile is mentioned first because it offers an exceptional degree of durability. All of these floors provide a wide range of color and design.

General Classrooms

The choice of durable resilient floors for general classrooms is most likely to center upon linoleum or asphalt tile. However, linoleum is the quieter of the

two. While Linotile and rubber tile are also suitable floors for classrooms, their cost is higher.

Library

Quietness is frequently the first requirement for a library floor. Both cork tile and rubber tile offer this quality. Rubber tile also offers color and luxurious appearance. Cork tile, because of its porosity, requires more than average maintenance.

Cafeterias and Domestic Science Classrooms

Floors in cafeterias, kitchens, and domestic and industrial science classrooms are exposed to grease and oil spillage. The most serviceable and attractive floor which meets these conditions is greaseproof asphalt tile. The colors in which it is made match standard asphalt tile and will harmonize with any decorating scheme. If these areas are above ground level and are not overly exposed to grease, Linotile and linoleum will give satisfactory service.

Gymnasiums

Gymnasiums and locker rooms require serviceable floors. For these areas asphalt tile is frequently selected. It offers a firm playing surface, and courts can be outlined in tile colors. Industrial asphalt tile, designed for serviceability and made only in black,

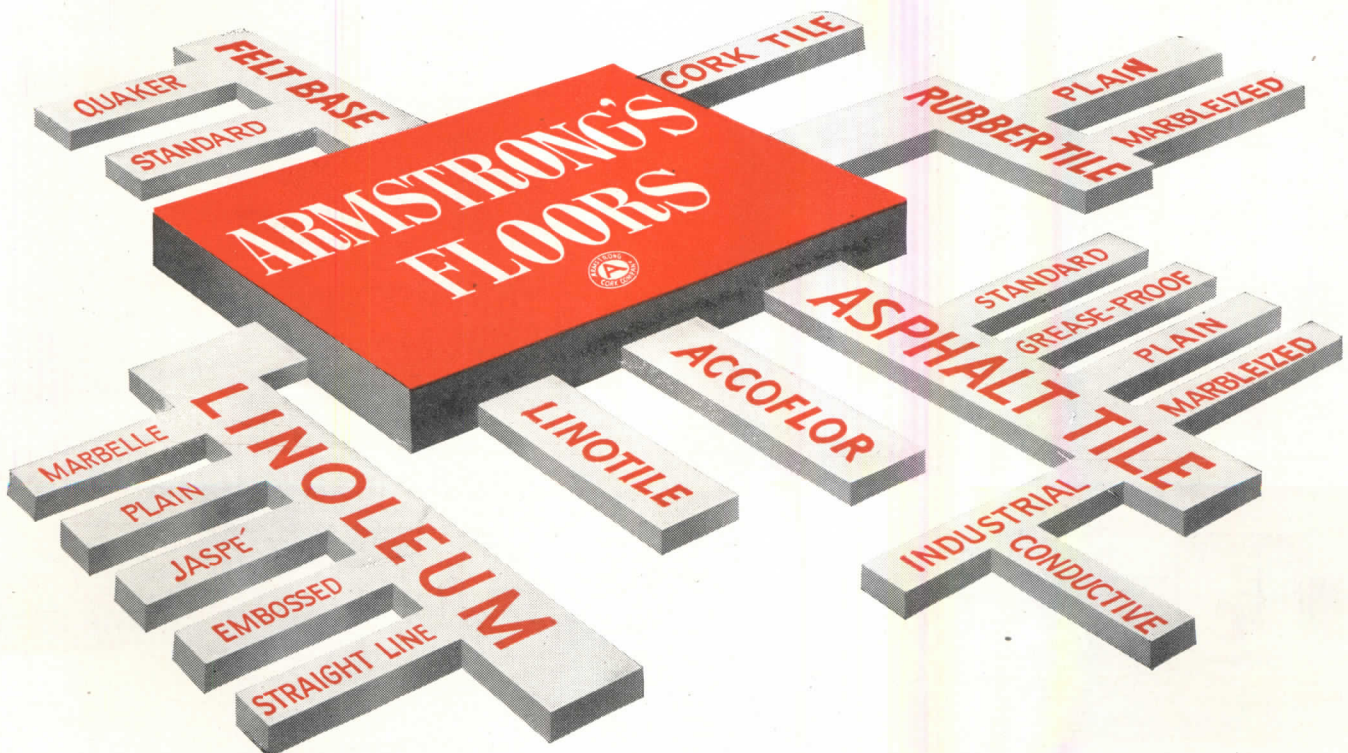

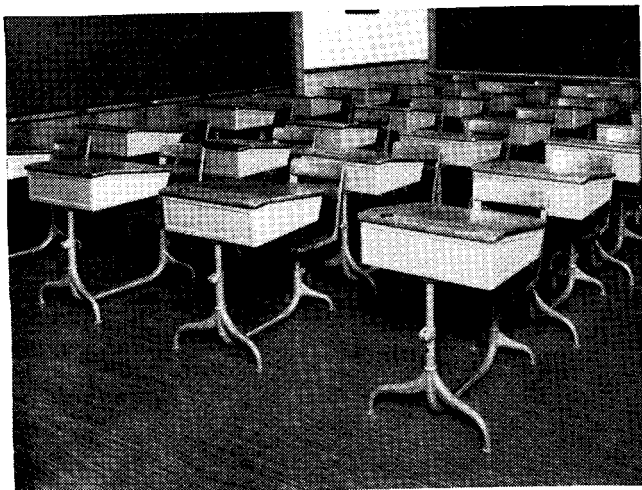

Linoleum is often selected for classrooms because of its underfoot comfort, durability, and ease of maintenance. Its unlimited design possibilities make it particularly adaptable for kindergartens and other classrooms where long-wearing, functional, and decorative floors are desired.



Asphalt tile presents many opportunities for colorful floors in cafeterias, kitchens, and other rooms located in basements or on grade level areas. Greaseproof asphalt tile is recommended for these floors as it is not harmed by spilled foods, greases, and other organic solvents.

offers durability at low cost. In locker rooms asphalt tile will not be affected by water, and should individual tiles be damaged by abuse, replacement is quite simple.

Industrial Classrooms

Floors in print shops and other industrial arts classrooms should provide comfort underfoot and be able to withstand shock. Asphalt tile is recommended for these areas because it is not usually harmed by falling tools or by wheels of trucks and dollies. It reduces breakage and dulling of dropped tools. Where color is not important, industrial asphalt tile will cut costs.

Basement or On-Grade Floors

Any of the resilient flooring materials can be used satisfactorily over suspended subfloors of either wood or concrete. Asphalt tile is recommended for use over subfloors which are on or below grade.

Costs and Maintenance

As a general rule, Linotile, rubber tile, and cork tile are slightly higher in first cost than linoleum and asphalt tile. There is a variation in cost according to color for linoleum in plain colors, asphalt tile, and rubber tile. Generally speaking, the darker the color, the lower the cost.

Resilient floors, as a group, are comparatively easy and economical to maintain. Linotile, linoleum, rubber tile, and asphalt tile require only a minimum of maintenance effort.

School floor maintenance can be further simplified through the use of linoleum flash type or asphalt top-set cove base which eliminates all dirt-catching corners at the floor-wall joint. The flash type continues the linoleum floor several inches up the walls. The asphalt top-set type is pre-formed and is placed on top of the resilient floor.

Should you wish assistance in selecting resilient floors, the Armstrong Cork Company will be glad to be of service. We manufacture all types of resilient flooring and therefore are in a position to offer you unbiased recommendations on flooring problems. Inquire at any Armstrong office or write stating your problem to Armstrong Cork Company, 2405 State St., Lancaster, Pa.



In libraries and other classrooms where noise should be held to a minimum, rubber tile is frequently preferred because of its high resilience. Cork tile, often rated the highest in resilience, requires more than average maintenance. Where cost is important, linoleum is suggested.

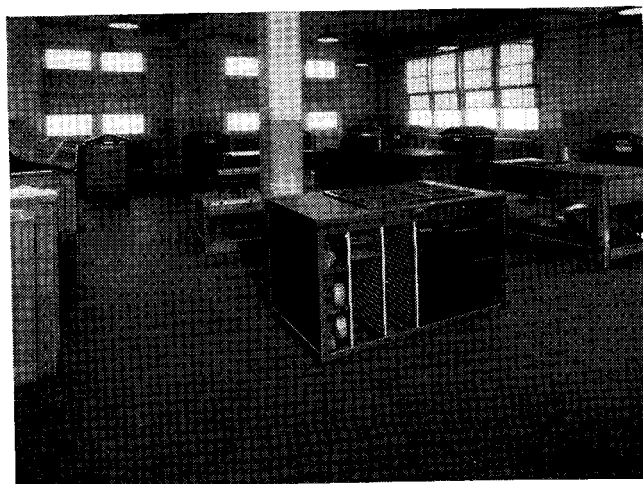

Industrial classrooms, usually located on ground or basement floors, need a flooring that can withstand the moisture and alkali in the concrete subfloor. Both standard and industrial asphalt tile withstand severe wear and are highly recommended for these classroom areas.

*Build for tomorrow
with what
they want today!*

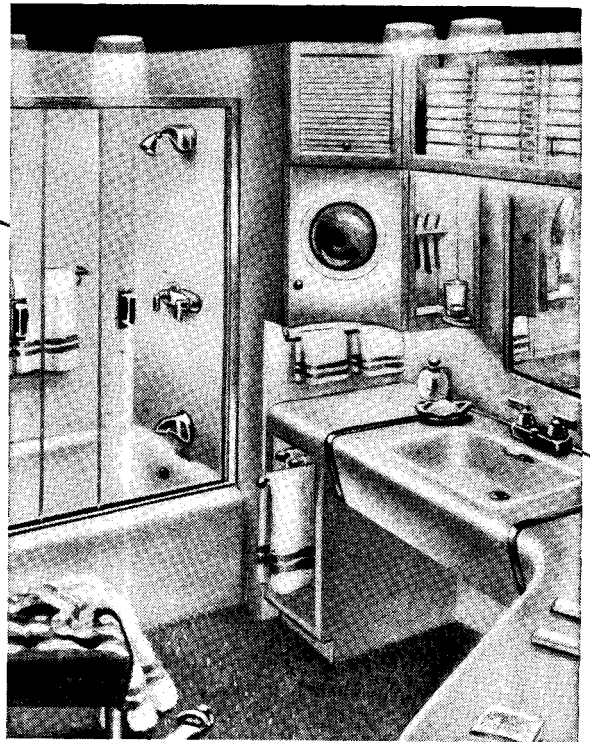

Important for modern comfort. Baths, showers, shaves are just three of the 140 household uses for hot water made easier and more pleasant by the always-on-tap hot water from an automatic Gas water-heater.

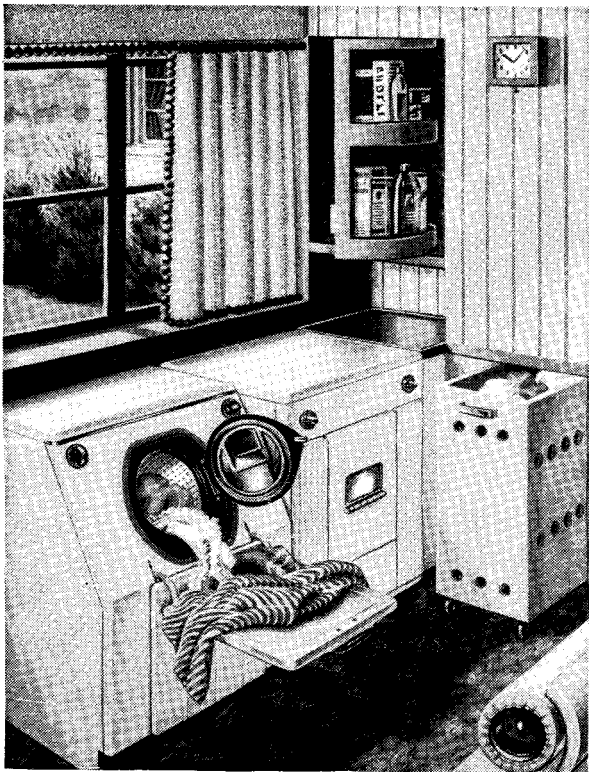

Essential in the modern laundry. Automatic washing machine manufacturers themselves recommend Gas heated water for best results. Because — an automatic Gas water-heater provides the most practical way of getting *quick-recovery* hot water in sufficient quantity — economically!

Where automatic gas water-heating is a modern "must"

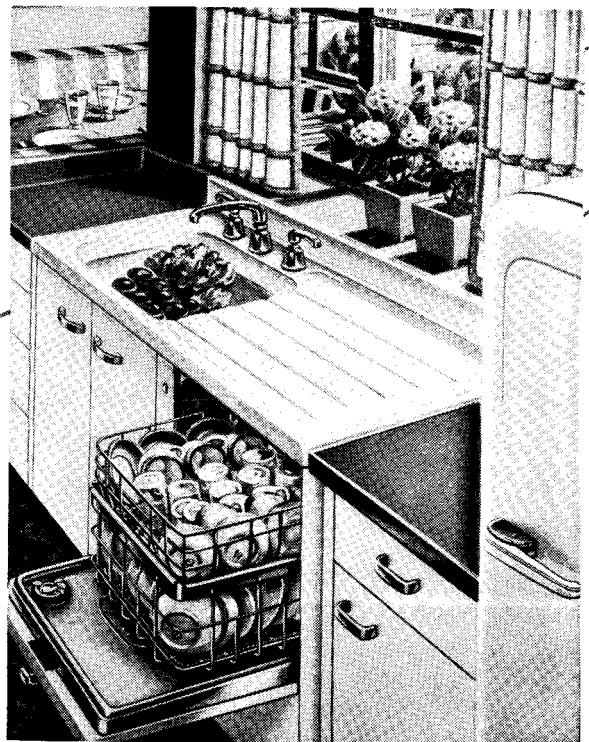

Vital to a modern dishwasher. To be efficient, the new dishwashers must have plenty of high temperature water. An automatic Gas water-heater is the only *economical* system that gives this kind of constant hot water supply.

Why an automatic gas water-heater is wanted "most"

Most reliable . . . Gas for water-heating enjoys a record for continuity of service unrivaled by any other fuel. It is dependable. Needs no fuel storage. Is less liable to interruptions. Delivers adequate supplies of hot water at any desired temperature with a minimum of repair and adjustment!

Most convenient . . . An automatic Gas water-heater requires no running downstairs to light up, no watching, no waiting. It is controlled by an automatic thermostat

which maintains *really* hot water in a heavily insulated tank and turns Gas off when need has been satisfied.

Most economical . . . An automatic Gas water-heater uses the *exact* quantity of fuel needed—no more! Waste of both water and fuel is reduced. Costs less to purchase, for *faster recovery* means smaller storage capacity is required for any given amount of hot water. And it operates with uniform economy all year 'round!

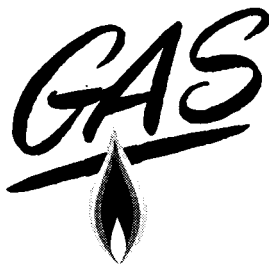

FOR THE LAST WORD IN
AUTOMATIC WATER-HEATING
AMERICAN GAS ASSOCIATION

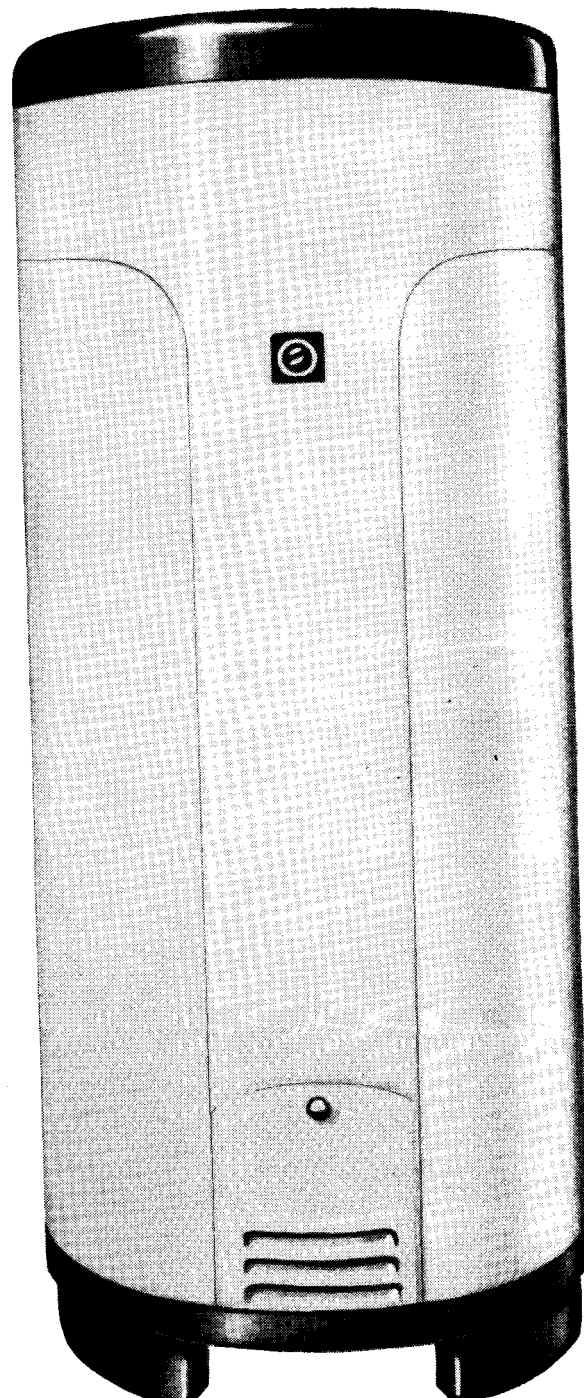

What to watch for in specifying automatic gas water-heaters

- 1. Size . . .** Be sure heater is large enough for client's needs! Check size of family, number of bathrooms, amount of home laundry, immediate prospect for other automatic equipment requiring hot water.
- 2. Type . . .** Recommend fast recovery storage heater for best all-round service. It is the most modern method of assuring continuous hot water 24 hours a day . . . and a must where automatic dishwasher or cycle washing machine is installed.
- 3. Placing . . .** Specify position of heater so that there is a minimum loss of heat from heater to point of use. And place close to flue.
- 4. Seal of Approval . . .** Insist on only those automatic Gas water-heaters which have been tested and approved for safety, durability and efficiency in the Laboratories of the American Gas Association.



Remember!

Automatic Gas water-heaters benefit you as much as they do your clients. They take up little building space . . . need only the simplest connections . . . yet add greatly to the popular appeal of today's homes. Most important of all, they build customer satisfaction! For like all modern Gas appliances—such as automatic Gas ranges built to "CP" standards, automatic Gas refrigerators, automatic Gas space heaters and year 'round Gas air-conditioning—these ultra-efficient Gas water-heaters enhance the value of any home . . . add stature to your reputation as designer and builder of *livable* living units! For technical details, see your local Gas Company.

Orchids to...

Ferro-Therm

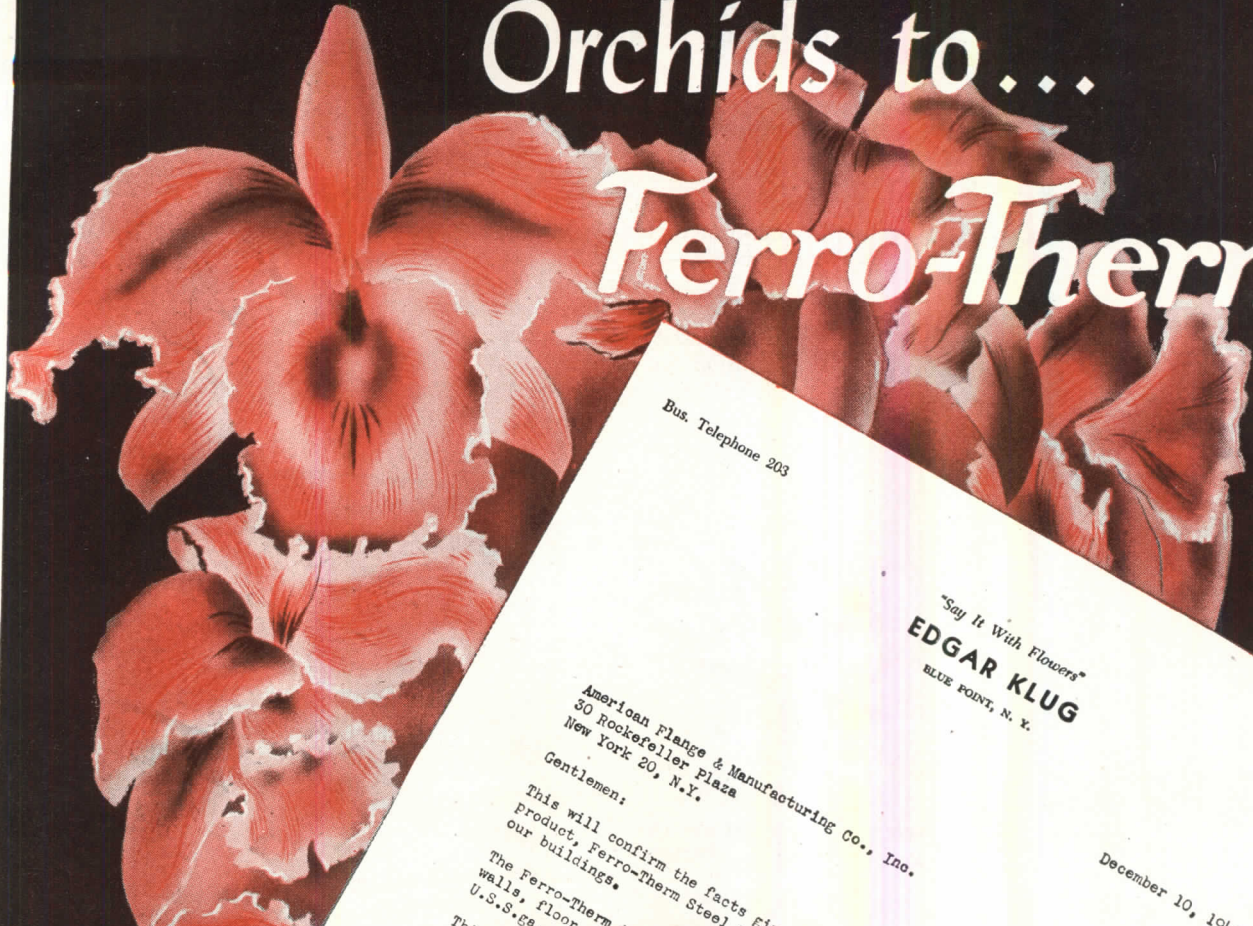

Bus. Telephone 203

"Say It With Flowers"
EDGAR KLUG
BLUE POINT, N. Y.

Res. Telepho

American Flange & Manufacturing Co., Inc.
30 Rockefeller Plaza
New York 20, N.Y.

December 10, 1946

Gentlemen:

This will confirm the facts given to you regarding the performance of your Product, Ferro-Therm Steel Insulation, in the fire of November 7 in one of our buildings.

The Ferro-Therm installation consists of a walk-in refrigerated room. The walls, floor, and ceiling of this room are insulated with 4 sheets of #38 U.S.S.g.a. Ferro-Therm.

This room is located in the boiler house of our building. On the morning of November 7, fire broke out and completely gutted the interior of the boiler house. The fire was freely blazing by the time it was discovered, and it is probable that 4 or 5 hours elapsed from the outbreak of the fire to the time it was completely extinguished.

The fire burned freely around the Ferro-Therm insulated room and charred the wood sheathed refrigerator door of the room. However, after the fire was extinguished and we opened the refrigerated room, we found that the temperature had risen no more than 20° above normal operating temperature of the room, and no smoke had entered the room. In consequence, our out flowers stored in this refrigerated room were entirely undamaged.

These facts are given to you with the understanding that they may be reproduced in your Ferro-Therm data as they provide to interested parties pertinent information regarding the insulation value and fire protection of your product.

very truly yours,

Edgar Klug

Ferro-Therm
BIG U.S. PAT. OFF.
STEEL INSULATION

Fully Protected By U. S. and Foreign Patents Issued and Patented

AMERICAN FLANGE & MANUFACTURING CO., INC.
Ferro-Therm Division, Dept. AR
30 Rockefeller Plaza, New York 20, N. Y.

Please send me, without obligation, complete information on Ferro-Therm Steel Insulation.

Name
Firm
Street
City
Zone
State.....

AMERICAN FLANGE &
MANUFACTURING CO., INC.,
30 ROCKEFELLER PLAZA,
NEW YORK 20, N. Y.

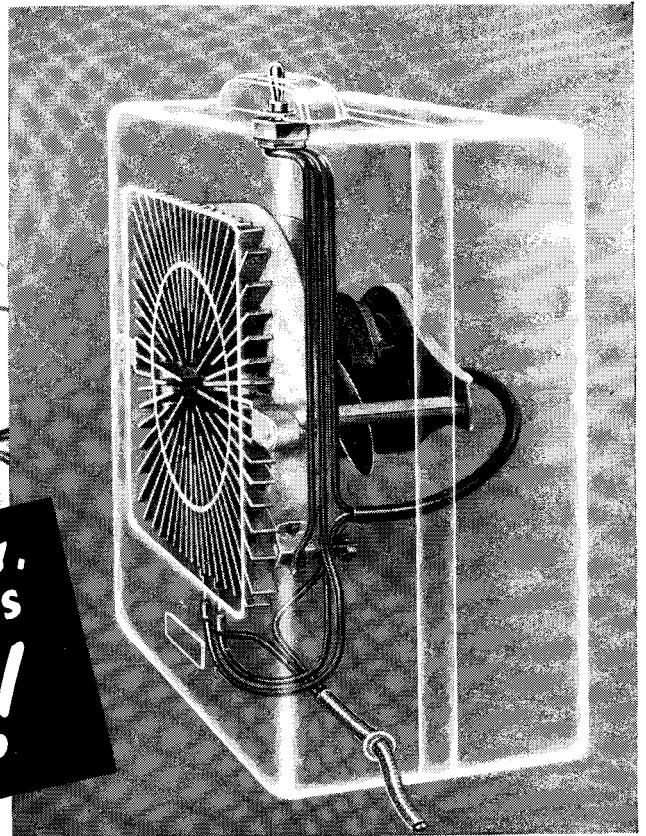

Model PJ-13 Portable Room Heater. 110 volts A.C.; 1320 watts; 4507 BTU. 13" high, 11½" wide, 7" deep.

Only **ELECTROMODE**

HAS THE **SAFETY-GRID!**

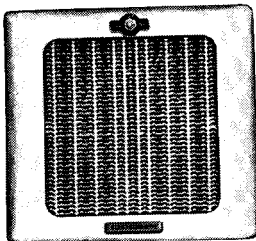

Model WJ-13 Bilt-in-Wall Small-Room Heater. 110 volts A.C.; 1320 watts; 4507 BTU. Approximate wall opening required: 9½" x 11½".

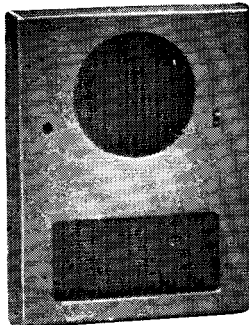

Model W-12 Bilt-in-Wall Room Heater. 230 volts A.C.; 1500 to 3000 watts; 5122 to 10245 BTU. Approximate wall opening required: 14¼" x 18¼".

For Booklet 46-*Illustrating and describing Electromode Room Heaters*, write Department A-57.

PROGRESSIVE architects are making a real hit with home-builders by specifying this newest idea in home heating. Electromode All-Electric Heat provides safety, convenience, comfort and cleanliness no other type of home heating equipment can offer. Electromode's exclusive Safety-Grid Heating Element (see X-ray view above) has no exposed hot or glowing wires — no danger of fire, shock or burn.

Electromode All-Electric Room Heaters — and Unit Heaters for industrial space heating — are quality products built to give service-free operation over long periods of use. Specify Electromode and you assure your customers of complete heating satisfaction.

ELECTROMODE CORPORATION • 45 Crouch Street • Rochester 3, N. Y.

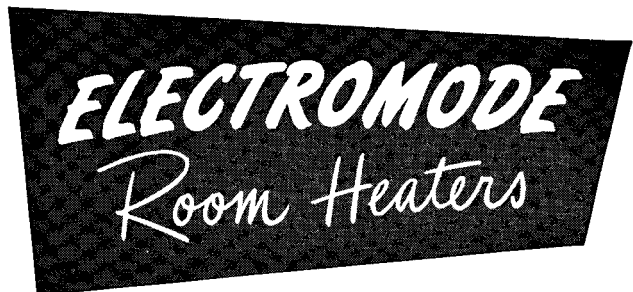

WORLD'S LEADING EXCLUSIVE MANUFACTURER OF ALL-ELECTRIC HEATERS

Ingersoll
UTILITY UNIT
TRADE MARK



Pictured here are a few of the 182 comfortable homes built during the past year by John R. Worthman, Inc., in Ft. Wayne, Indiana. These and similar homes are an ideal answer to the current housing shortage. Each of 35 Worthman homes now under construction is being speeded to completion, thanks to the Ingersoll Utility Unit.

**INGERSOLL UTILITY UNIT
SAVES TIME AND SPACE IN MAJOR
HOUSING DEVELOPMENTS**

**Hundreds of Leading Builders Everywhere
Are Including Utility Units in 1947 Projects!**

All over the country forward-looking builders, convinced of the efficiency, convenience and adaptability of the Ingersoll Utility Unit, are ordering thousands of these single-engineered assemblies for immediate installation. In modern housing developments in New York, Dayton, Detroit, Indianapolis, Boston, San Francisco, in towns

and cities everywhere, more and more of these easy-to-install units are daily proving the means to economy of space and lower all-around cost. With each part engineered to fit snugly in its place, this practical, compact and sturdy unit, complete from one source, contains everything needed for comfort and homemaking efficiency.

One of the buildings that will house 544 attractive, modern apartments being built by Nettleton & Baldwin, Inc., Seattle, Washington. Each will include easy-to-install, time and space-saving Ingersoll Utility Units. Adaptability of the unit to individual plans enable them to incorporate more living space for less money in these multiple-unit dwellings.

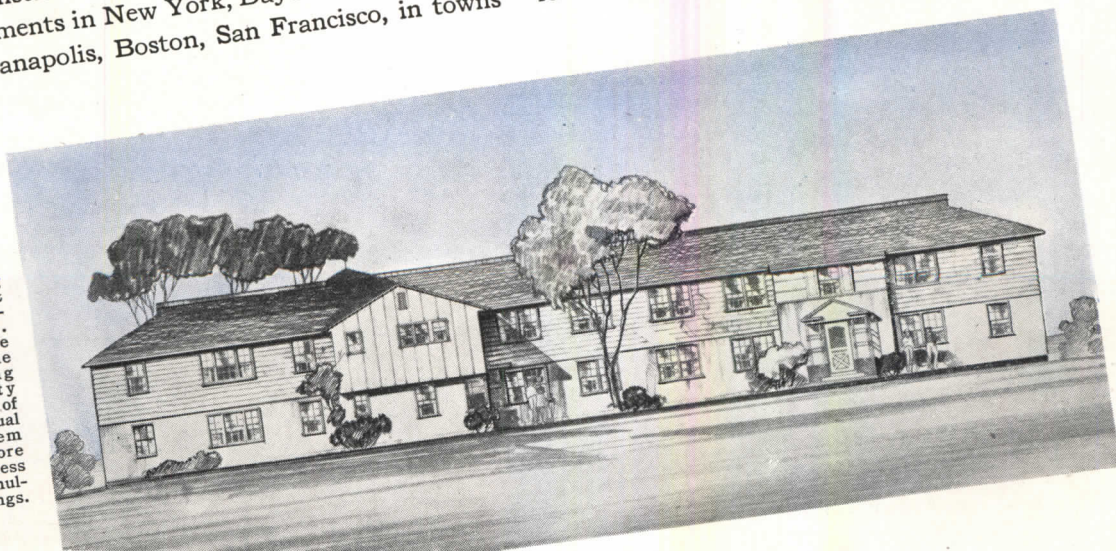

PRODUCT OF
**BORG-
WARNER**

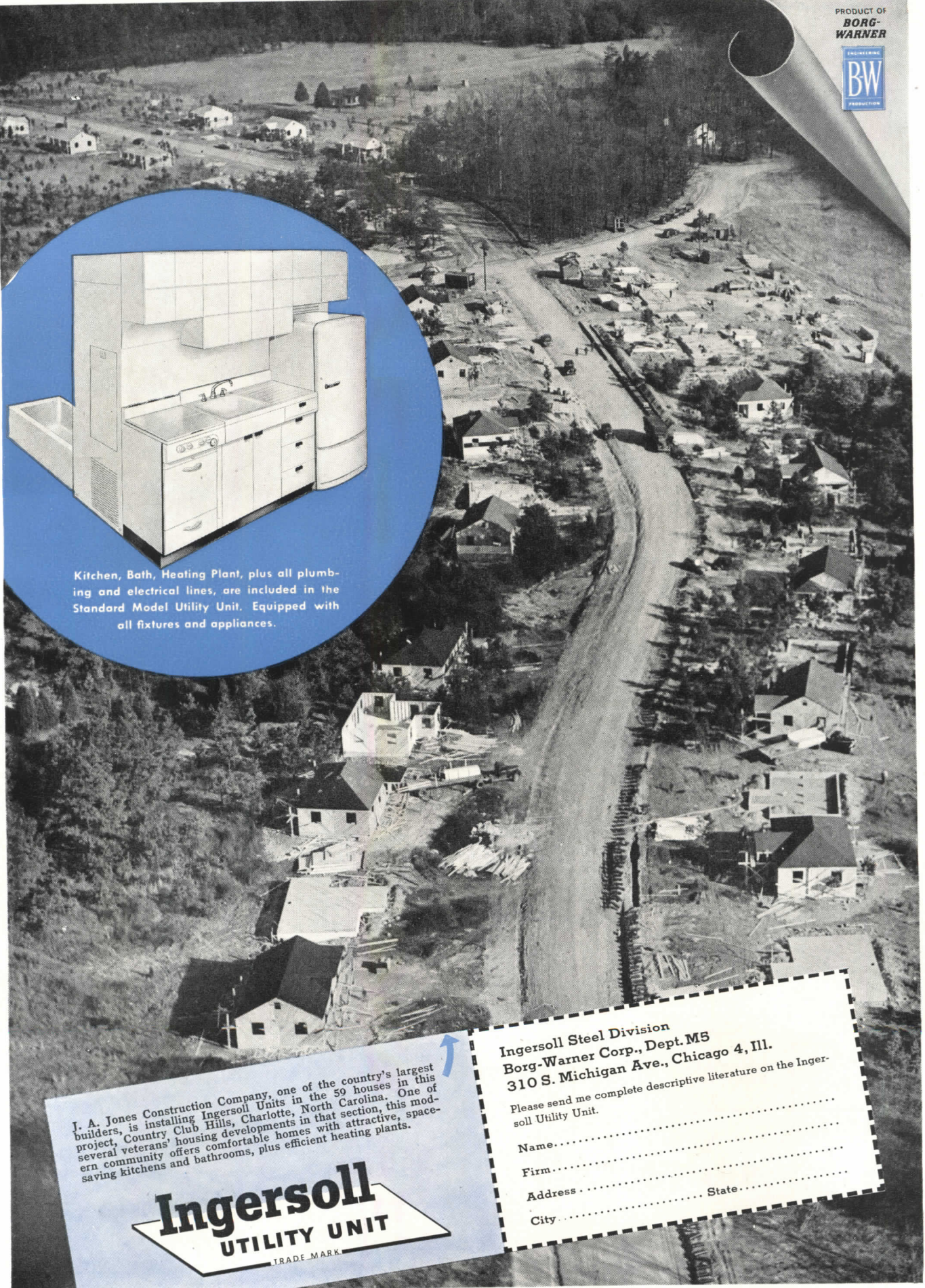

Kitchen, Bath, Heating Plant, plus all plumbing and electrical lines, are included in the Standard Model Utility Unit. Equipped with all fixtures and appliances.

J. A. Jones Construction Company, one of the country's largest builders, is installing Ingersoll Units in the 59 houses in this project, Country Club Hills, Charlotte, North Carolina. One of several veterans' housing developments in that section, this modern community offers comfortable homes with attractive, space-saving kitchens and bathrooms, plus efficient heating plants.

Ingersoll
UTILITY UNIT
TRADE MARK

Ingersoll Steel Division
Borg-Warner Corp., Dept. M5
310 S. Michigan Ave., Chicago 4, Ill.

Please send me complete descriptive literature on the Ingersoll Utility Unit.

Name.....
Firm.....
Address..... State.....
City.....



When a Couple of Inches Mean a Lot...

YOU need doors and plywood. Our ability to meet your needs largely hangs on a couple of inches in the width of the doors and plywood you specify.

The production of stock sizes means multiplied production—more doors and plywood for more customers. On the other hand, odd-size doors and plywood mean manpower wasted—production slowed—orders unfilled.

So plan for stock sizes only and we'll plan to meet your needs.

Roddiscraft WAREHOUSES:

CAMBRIDGE 39, MASS. 229 Vassar Street	LOUISVILLE 10, KENTUCKY 1201-5 S. 15th Street
CHICAGO 8, ILL. 1440 W. Cermak Road	LONG ISLAND CITY, N. Y. Review & Greenpoint Ave.
CINCINNATI 2, OHIO. 457 E. Sixth Street	LOS ANGELES 11, CALIF. 2860 E. 54th Street
DALLAS, TEXAS. 2800 Medill Street	MARSHFIELD WISCONSIN
DETROIT, MICH. 11855 E. Jefferson Ave.	MILWAUKEE 8, WIS. 4601 W. State Street
KANSAS CITY 8, MO. 2729 Southwest Blvd.	NEW YORK CITY 18, N. Y. 515 W. 36th Street
	SAN ANTONIO, TEXAS. 727 N. Cherry Street

DEALERS IN ALL PRINCIPAL CITIES

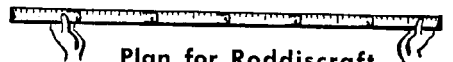
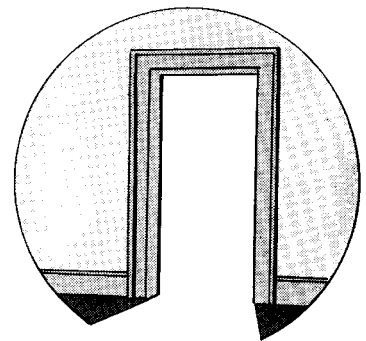

Plan for Roddiscraft doors and plywood in stock sizes—

Roddiscraft

Roddis Lumber & Veneer Co.

MARSHFIELD, WISCONSIN

Roddiscraft warehouses, located at strategic points throughout the country, have been set up to save you time and serve you better—by making stock size doors and plywood available when and where you want them. Roddiscraft warehouse service is based on production and stocking of doors and plywood in stock sizes. Only by limiting ourselves to stock sizes can we give you the additional value of "on hand" service at convenient locations.

The 2nd International Lighting Exposition Announces MERIT AWARD CERTIFICATES

*for Electrical Contractors... Electrical Wholesalers...
Architects... Utility Lighting Men... Consulting Engineers*

on the Subject

“What Planned Lighting Can Do”

Offering Merit Award Certificates for Planned and Engineered Lighting Installations Completed in 1946 and 1947, plus 12 Gold Seal Awards of \$100 each. }

Closing Date: Sunday, August 31, 1947

DURING this year or last, you have doubtless had a part in the designing, planning or production of at least one industrial or commercial lighting or floodlighting installation that has proved exceptionally effective... an outstanding example of the benefits to be derived from lighting properly planned and installed.

It is to direct industry-wide attention to such achievements... to stimulate thinking along similar lines among the thousands who will attend the Exposition, that this competition on “What Planned Lighting Can Do” is sponsored by the 2nd International Lighting Exposition and Conference.

For you, this represents a unique opportunity to contribute to the knowledge of better seeing through better lighting. Further, thousands will see your entry on display at the Exposition and reported in the trade magazines, and thus you and your

company will gain nation-wide recognition for your accomplishment.

4 separate competitions with opportunities for joint entries

There will be separate competitions for each of the following groups:

1. Electrical Contractors
2. Utility Lighting Representatives
3. Architects and Consulting Engineers
4. Wholesalers' Lighting Specialists and Salesmen

Thus, for example, Electrical Contractors' entries will compete only with submittals from other Electrical Contractors, Utility Men's entries will compete only with other Utility Lighting representatives' entries, etc. In addition, where the installation is the cooperative work of men in two or more of the above classifications, the entry may be

submitted by the two or more involved, and entered in each of the applicable classifications.

Merit Awards and Gold Seal Cash Awards

From the entries received, the Board of Judges will select those which are judged eligible for Merit Award Certificates. All of these will be placed on exhibit at the Exposition. In addition, the judges will select the twelve judged best, three from each classification, which will receive Gold Seal Merit Awards of \$100 each... a total of \$1200 in cash prizes. Decision of the Board of Judges is final.

Send for Official Entry Blank and Rule Book

For an official entry blank and a copy of the rules, write MERIT AWARD COMMITTEE, Room 818, 326 West Madison Street, Chicago 6, Illinois.

“Plan Tomorrow's Lighting Today” at the 2nd INTERNATIONAL LIGHTING EXPOSITION and CONFERENCE **Chicago, Nov. 3-7, 1947, Stevens Hotel.** Sponsored by INDUSTRIAL and COMMERCIAL LIGHTING EQUIPMENT SECTION of the **National Electrical Manufacturers Association**

2283



The above Announcement is published in this Magazine as a Contribution to the Advancement of “PLANNED LIGHTING” by

BENJAMIN

makers of Industrial

Lighting Equipment and Floodlights

Distributed Exclusively through Electrical Wholesalers. BENJAMIN ELECTRIC MFG. CO., Des Plaines, Illinois



reasons why you should specify

WIRE AND CABLE INSULATION MADE FROM

GEON *plastics*

for industrial, domestic, manufacturing and utilities wiring

Resistance to ozone, wear, sunlight, water, chemicals, and most other normally destructive factors

14 colors including NEMA standards

More conductors in a given space

Excellent electrical properties

Thin coating of insulation

Ease of handling

Easy stripping

Light weight

Be sure to specify wire or cable insulated with GEON in order to get *all* these advantages. Or, for information regarding special applications please write Department N-5, B. F. Goodrich Chemical Company, Rose Building, Cleveland 15, Ohio. In Canada: Kitchener, Ont.



B. F. Goodrich Chemical Company

A DIVISION OF
THE B. F. GOODRICH COMPANY

GEON polyvinyl materials • HYCAR American rubber • KRISTON thermosetting resins • GOOD-RITE brand chemicals



The Furnace that brought

Beauty
to the Basement



"The Sun Never Sets
with MOR-SUN!"

Architects must be practical. Dream castles are all right on paper... but Home, Sweet Home needs a heating system . . . a healthful and automatic heating system.

And there's no law against it being beautiful too. In fact, what with rumpus rooms and basement bars, a thing of beauty in a heating system can be a joy forever!

And that means the MOR-SUN . . . the winter air-conditioning furnace that gives Beauty as well as BTU's!

MOR-SUN . . . the pressed steel factory-assembled packaged furnace that heats, conditions, circulates, filters, humidifies and continuously renews the air . . . and brings beauty to the basement!

MORRISON STEEL PRODUCTS, Inc., BUFFALO 7, N. Y.

Morrison's nationwide dealer organization is at your Service. Write us for the address of our representative nearest you.

It's the
NEW STANLEY HARDWARE
 you saw advertised, Madam!



Let your customers see this beautiful new line ... operate the latches themselves ... actually feel how these roomy handles fit the hand.

HERE'S A SURE-FIRE LINE if there ever was one! Sturdy, beautiful cabinet hardware, styled after a nation-wide consumer survey, and backed up by extensive advertising in consumer, builder and architectural magazines ... a line that combines the beauty of jewel-like plastics with the rugged utility of pressure cast, rust-proof alloys.

Ask your jobber about this new Stanley Cabinet Hardware and the *working* counter displays. The Stanley Works, New Britain, Connecticut.

STANLEY

Trade Mark

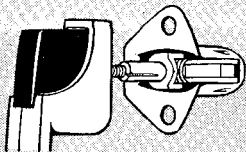

SELF-ADJUSTING LATCH. Unique new "Trigger" latch design ... automatically adjustable to doors from 3/4-in. to 1 1/2-in. Also oil-impregnated friction catches.



"ITEM-IZED" ENVELOPES. Each item packed complete with all necessary parts. Packed for easy stocking in same size boxes, with easy-to-read labels, giving complete data.

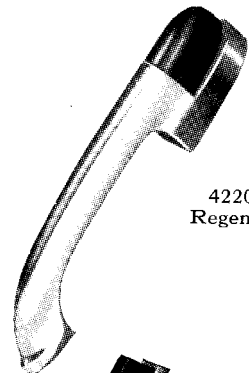

4220
 Regency

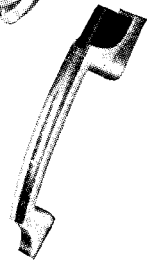

4222
 Priscilla

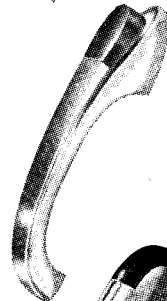

4223
 Century



4224
 Newport

Did you ever see a

water-logged
duck?

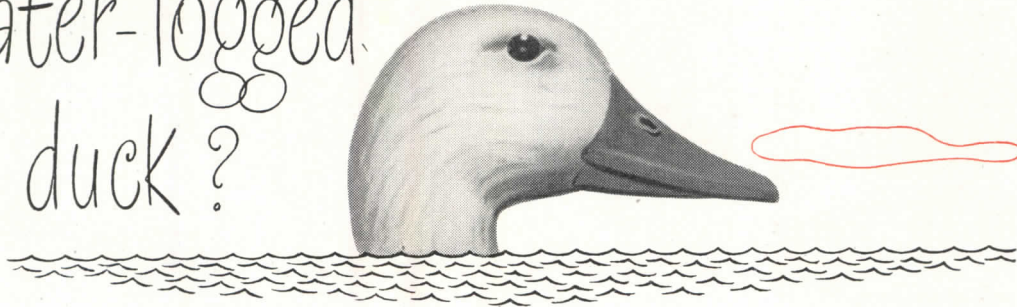

Ducks don't get water-logged because their feathery dress is naturally water-repellent. If this property were removed, they would sink like billiard balls.

Koppers roofs, too, are naturally water-repellent. Built up of Koppers Old Style Pitch and Tar-saturated Felt, they repel the moisture of pelting rains and of melting snow and ice. Coal tar pitch, the basic ingredient in Koppers built-up roofs, resists continual or intermittent exposure to water. This quality makes Koppers roofs a natural for modern

homes which utilize flat roofs for cooling purposes.

The natural water-repellancy is equaled, also, by the resistance of Koppers roofs to the sun's rays. Actually, by the process of "cold flow", cuts sustained by roofs heal themselves.

When you specify roofing, consider these advantages of Koppers Old Style Pitch and Tar-saturated Felt.

KOPPERS COMPANY, INC.
PITTSBURGH 19, PA.

Naturally, a Koppers roof for long life



**ROOFING
& WATERPROOFING**



HOOD RUBBER TILE

Smartness of appearance is vital to most modern interiors. Yet it must not be achieved through any sacrifice of the utility factor. This is why so many architects now specify Hood Rubber Tile Flooring. It has smartness of appearance, endurance of quality and an adaptability limited only by the architect's own ideas of style, color or design.

For nearly a quarter of a century Hood Resilient Flooring has stood the test of time and traffic. Floors laid years ago in many of America's finest buildings, ships and trains still retain their original color and attractive appearance. They show few signs of wear with no loss of resiliency.

Because it is backed by B. F. Goodrich leadership in research and Hood excellence in manufacture, you get real flooring satisfaction when you call for Hood Rubber or Asphalt Tile—leader since 1925. See Sweet's, or send for new color catalog.

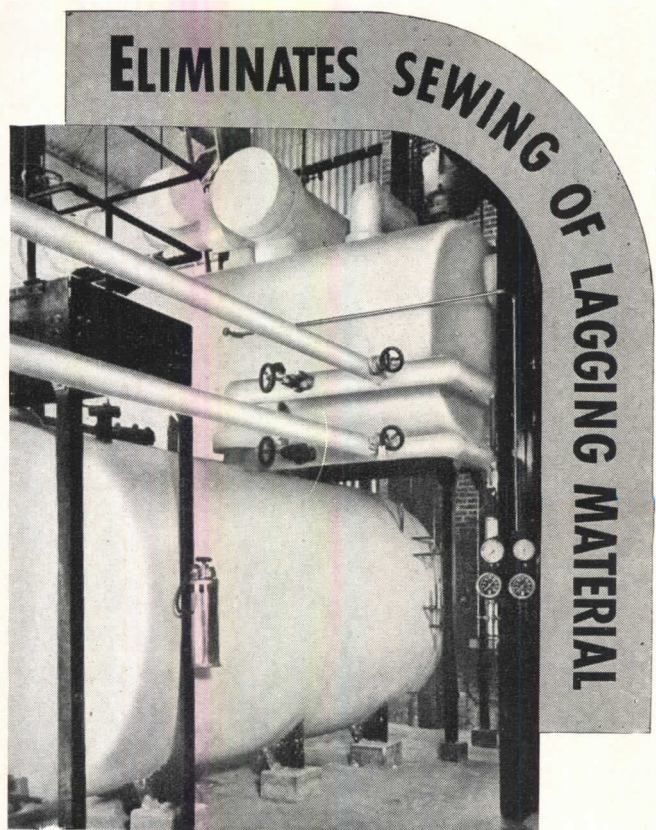

Insulation on pipes, ducts and boilers must be protected by lagging material. But you need no longer spend the time or the money to have this material sewn . . . not when Arabol Lagging Adhesive is used.

This adhesive holds the canvas, asbestos, fibreglas or other covering firmly in place; dries in 4 to 6 hours; *leaves a sized finish*. The lagging material is neat-looking and fully protected—without the use of paint. (You can always add one coat for appearance, if you so desire.)

Maintenance is simplified—grease, oil, soot and dirt wash off easily. And the adhesive is vermin-proof . . . fire-retardant, too.

Arabol Lagging Adhesive has successfully passed rigorous tests by independent laboratories. The results show that it retains its adhesive powers despite exposure to extreme temperatures, to immersion in water, and to live steam.

Write us today for detailed facts and figures. Don't place open specifications on lagging work—insist on Arabol Lagging Adhesive. You can depend on it to fill your most exacting requirements for both utility and appearance. Also, ask about our cork cement for adhering cork to cork on refrigerator lines.

THE ARABOL MANUFACTURING CO.

Executive Offices: 110 East 42nd St., New York 17, N. Y.

CHICAGO—54th Ave. & 18th St. SAN FRANCISCO—30 Sterling St.

Branches in Principal Cities. Factories in Brooklyn, Cicero, San Francisco



Adhesives? . . . ARABOL!

Simplified Cooling

FOR EVERY PURPOSE

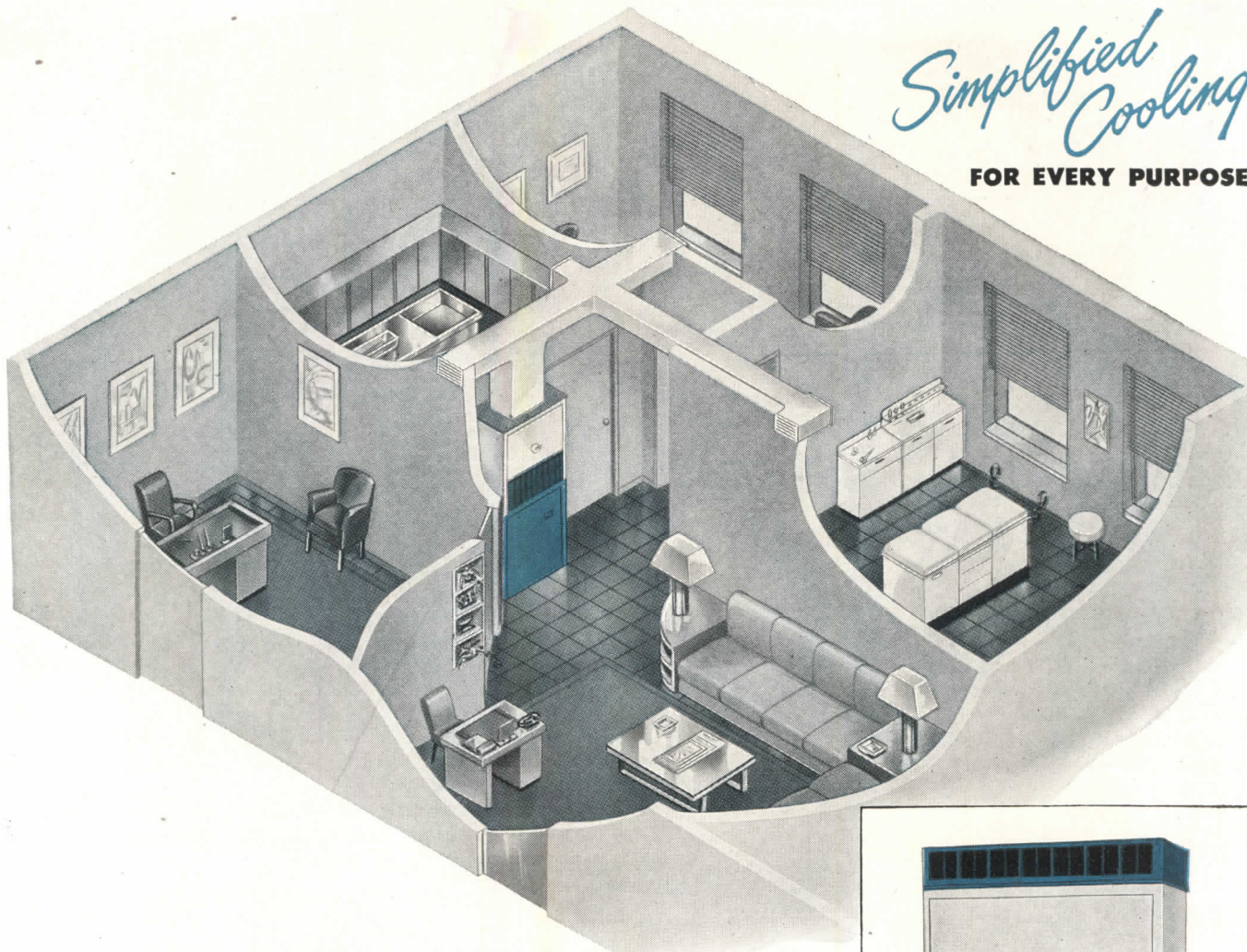

Economical, Easy-to-Install Air Conditioning For Doctors

DOCTORS benefit in many ways from air conditioning. A survey reveals that, in addition to making doctors and patients comfortable, air conditioning greatly improves staff efficiency, shuts out disturbing outside noise and contributes to the composure of patients under treatment. Because of compactness and flexibility of design, Chrysler Airtemp Packaged Air Conditioners fit exceptionally well into plans for such offices. They occupy very little floor space, and require only one electrical and two water connections. Completely self-contained and automatic in operation, these packages are engineered for long life at low operating and upkeep costs. For details, architects are invited to write

AIRTEMP DIVISION OF CHRYSLER CORPORATION, DAYTON 1, OHIO

In Canada: Therm-O-Rite Products, Ltd., Toronto

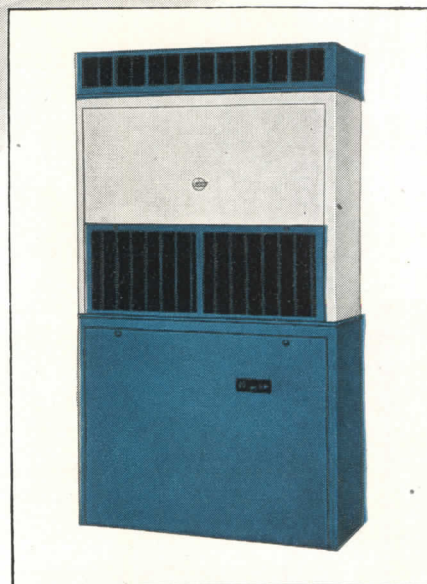

Packaged Air Conditioners are products of Chrysler Corporation engineering skill, famous around the world.

Automatically Yours

© 1947 Chrysler Corporation



PACKAGED AIR CONDITIONERS

HEATING • AIR CONDITIONING • COMMERCIAL REFRIGERATION

Durable, Attractive DOUGLAS FIR DOORS

Are Precision-Made to
Meet Modern Demands

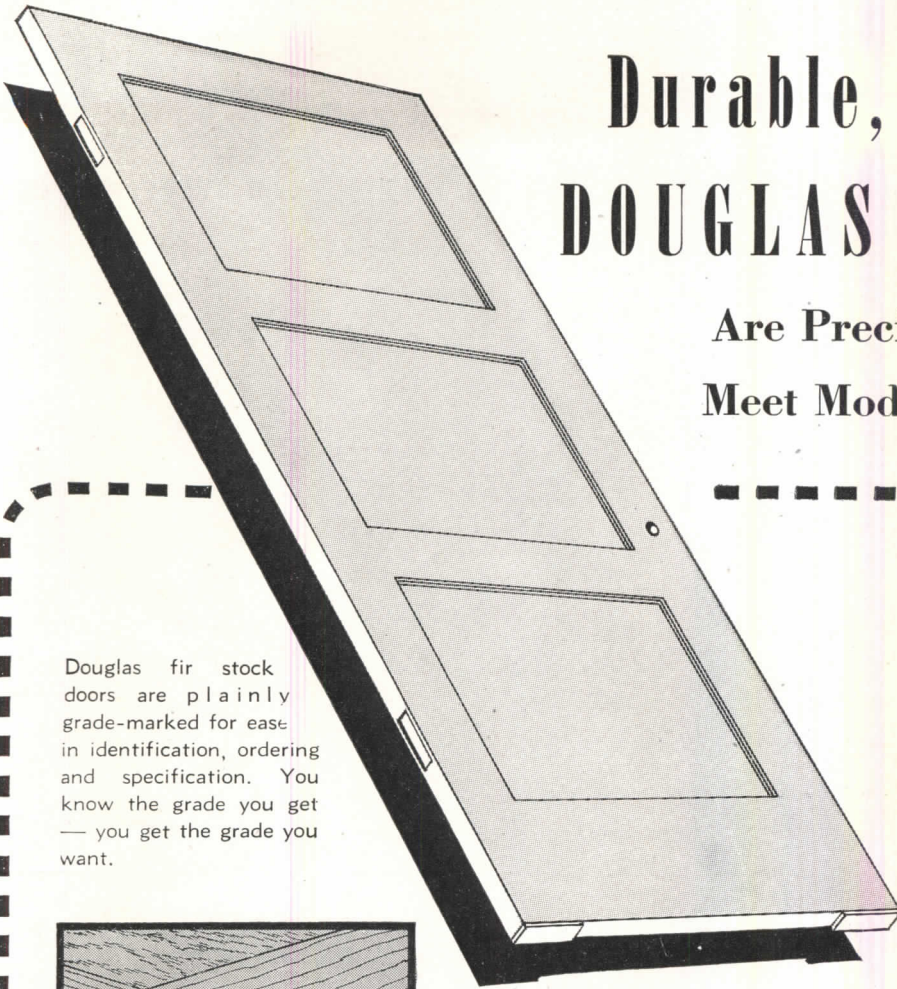

Douglas fir stock doors are plainly grade-marked for ease in identification, ordering and specification. You know the grade you get — you get the grade you want.

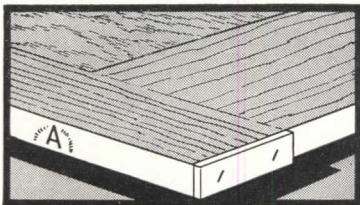

PRE-FIT

Douglas fir stock doors are pre-fit to exact size. No on-the-job fitting or cutting is necessary. Doors are scuff-stripped for protection in shipping.

PRE-SEALED

Douglas fir stock doors are pre-sealed — a feature which improves dimensional stability, reduces moisture absorption, and eliminates the need for one prime coat.

FACTRI-FIT

Douglas fir doors may also be ordered completely machined — not only pre-fit, but gained for hinges and mortised for locks as well. All work is done at the factory by modern, high-speed precision tools.

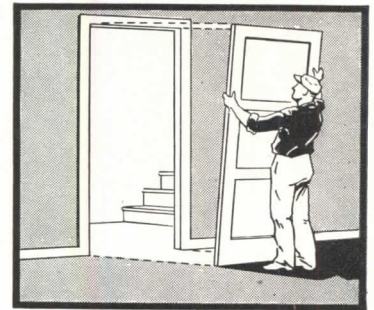

More Doors Soon!

It is a fact that the supply of Douglas fir doors will continue critical for a number of months. Two factors make this true: the present overwhelming demand — and the shortage of shop lumber. But production IS stepping up. Warehouse and dealer stocks should soon reflect this increased production. We suggest that you keep in touch with your regular source of supply.

DOUGLAS fir stock doors offer real advantages all along the line. Dealers offer them with the knowledge that their precision-made features meet the needs of every customer. Builders save time and money on every installation. Architects specify these fine doors knowing they will result in trimmer, more attractive installations. Prefabricators use them to speed line production. Check the advantages detailed at the left! The slight additional costs are more than offset by on-the-job economies.

**Douglas Fir
DOORS**
FIR DOOR INSTITUTE

Tacoma 2, Washington

Remember!
NATURE MAKES
DOUGLAS FIR
Durable!

Durable Douglas Fir Doors
are made from all-heart-
wood, vertical-grain, soft,
old-growth Douglas Fir.

THE NATIONAL ASSOCIATION OF FIR DOOR MANUFACTURERS

45th
Anniversary
Year



Edwin F. Guth, Sr., Founder of The Edwin F. Guth Company; Saint Louis. Now in the 45th Year of Lighting Leadership.

*"An Institution is
Only the Lengthened
Shadow of One Man"*

...EMERSON



Edwin F. Guth, Sr.

- **Founder** of the Edwin F. Guth Co., April 22, 1902.
- **Creator** of more than 150 lighting device patents.
- **Designer** of the world famous "BRASCOLITE", of which millions were sold; thousands are still in use the world over.
- **Originator** of the first fully "Packaged" Lighting Fixture, which helped put the Electrical Wholesaler into the lighting business.
- **Manufacturer** of beautifully designed cast bronze lighting equipment for many state capitol buildings, hundreds of post offices and churches, and other public institutional buildings from Coast-to-Coast; and in numerous foreign countries.
- **Producer** of finest reflector finishes as they were developed - Alzak Aluminum, Porcelain Enamel, 300° White, and Electroplated Finishes.
- **Inventor** of the famous GUTHFAN - the first improved fan over a 30-year period.
- **Director** of large industrial and banking institutions.
- **Named** "A Modern Pioneer on the Frontier of American Industry" by the National Association of Manufacturers.
- **Designer and Producer** of lighting equipment during all of a historical period - through Gas Fixtures, Gas Mantles, Combination Gas & Electric, Carbon, Gem, Tantalum, Tungsten, Mercury, Fluorescent and Germicidal - from 1902 to the present!
- **And as alert and active in his 72nd year as at any time in his busy life!**

A TRIBUTE TO A MAN FROM HIS SONS

We're proud of our Dad!

Proud of him as a business man—proud of him as a pioneer in the lighting industry—proud of him for his high ideals and unshakable principles.

But most of all—*we're proud of him as a parent!*

At home or at work, he's a human dynamo—alert, keen-witted, filled with a holy zeal for action. He's willing and eager to fight for his convictions in the face of extremest odds—and we believe he's proved himself right 99% of the time!

Yet, with all his dynamic activity, he has the happy ability to flash a twinkling smile or turn a cheery phrase that warms the heart through and through.

He's a grand man and a great Dad. We want to take this opportunity, in the seventy-second year of his life and the forty-fifth of his business success, to say, "Thanks, Dad! Thanks for drilling common sense and fairness into us. Thanks for getting us up bright and early every morning; and for teaching us the real meaning of life and work. Thanks just for being you—a darned swell Dad!"

EDWIN F. GUTH, JR.
FRED E. GUTH
JAMES B. GUTH

Guth

Lighting is **GOOD** Lighting ...
for Every Modern Lighting Need!

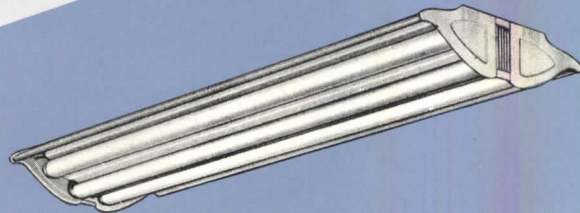
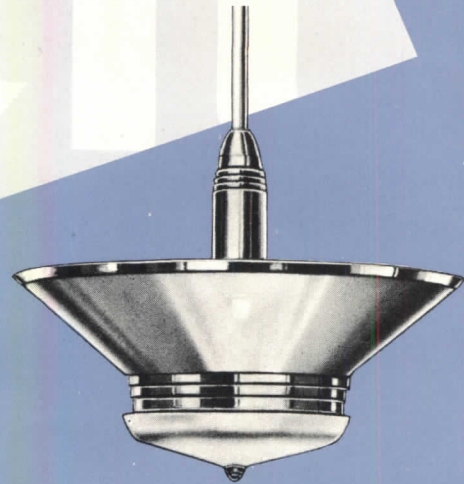
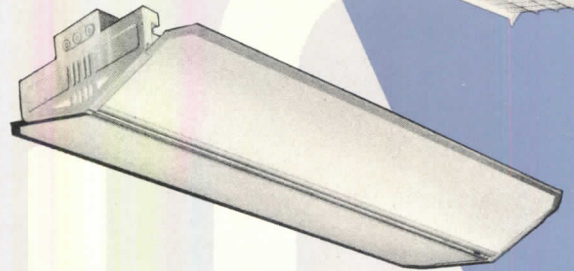
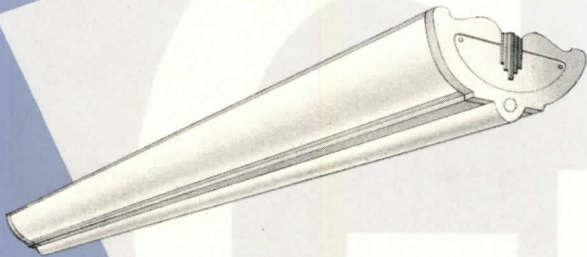
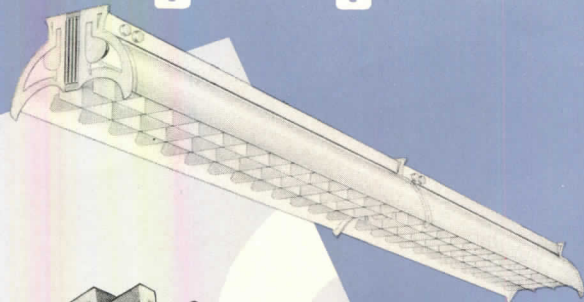
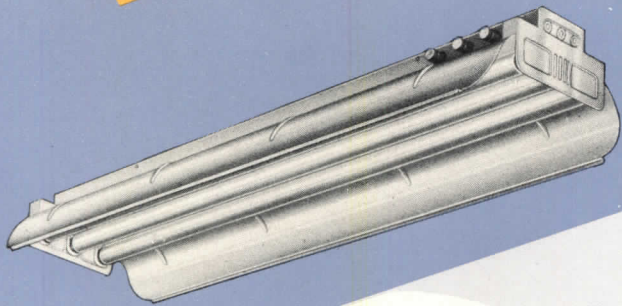

EXCLUSIVE REPRESENTATIVES IN 19 CITIES

ATLANTA, GA.
Phone: Crescent 3346
BOSTON, MASS.
Phone: Kenmore 2042
CHICAGO, ILL.
Phone: Harrison 2994
CINCINNATI, OHIO
Phone: Valley 7086

DALLAS, TEX.
Phone: D4-4471
DETROIT, MICH.
Phone: Dearborn 8713
LOS ANGELES, CALIF.
Phone: Prospect 1717
MEMPHIS, TENN.
Phone: 4-2170

NEW YORK, N. Y.
Phone: Barclay 7-9073
PHILADELPHIA, PA.
Phone: Lombard 3-4669
PITTSBURGH, PA.
Phone: Grant 4444
PORTLAND, ORE.
Phone: Broadway 0243

ROCHESTER, N. Y.
Phone: Canandaigua 1001M
ST. LOUIS, MO.
Phone: Jefferson 3200
ST. PAUL, MINN.
Phone: Emerson 5914
SALT LAKE CITY, UTAH
Phone: 3-2606

SAN DIEGO, CALIF.
Phone: Main 9578
SAN FRANCISCO, CALIF.
Phone: Douglas 8024
SEATTLE, WASH.
Phone: SE 2420
WASHINGTON, D. C.
Phone: Republic 2192

Guth

The **EDWIN F. GUTH CO.**

ST. LOUIS 3

LEADERS IN LIGHTING SINCE 1902



How **RED LEAD** stops **Electro-chemical Action** ...basic cause of **Rusting**

Modern science reveals many reasons *why* Red Lead has earned its place as the "standard" metal protective paint.

One very basic factor is Red Lead's ability to halt electro-chemical activity—the fundamental cause of rusting.

In this electro-chemical action, weak currents are generated, because of chemical and physical differences in the metal, as well as local differences in environment. As a result, the iron goes into solution and rusting is promoted.

These electro-chemical conditions are always present; but Red Lead eliminates their harmful effects.

Here's how: Red Lead possesses unique properties which enable it rapidly to convert the iron solubles into stable compounds. This forms a tightly adherent, protective film located at the interface of the metal and the Red Lead coating (see diagram).

This film, so thin it cannot be seen by the eye, is in direct contact with the

metal. It effectively inhibits electro-chemical action, and the consequent corrosion of the metal.

Naturally, for *continued* protection, the film must remain unbroken. Here again, in the same way, Red Lead heals any small breaks in the protective shield due to abrasive action or other causes.

Thus, the metal remains in a rust-inhibited condition as long as Red Lead coats the surface.



The Film that halts corrosion: *This diagram shows the protective shield, located at the interface of the metal and paint film. The formation and continuous maintenance of this film by Red Lead stops electro-chemical action...inhibits the metal from rusting.*

Remember, too, that Red Lead is compatible with practically all vehicles com-

monly used in metal protective paints, including many of the fast-drying resin types.

Specify RED LEAD for ALL Metal Protective Paints

The rust-resistant properties of Red Lead are so pronounced that it improves any metal protective paint. So, no matter what price you pay, you'll get a better paint if it contains Red Lead.

The benefit of our extensive experience with metal protective paints for both underwater and atmospheric use is available through our technical staff.

NATIONAL LEAD COMPANY: New York 6; Buffalo 3; Chicago 8; Cincinnati 3; Cleveland 13; St. Louis 1; San Francisco 10; Boston 6. (National Lead Co. of Mass.); Philadelphia 7. (John T. Lewis & Bros. Co.); Pittsburgh 30. (National Lead Co. of Pa.); Charleston 25. W. Va., (Evans Lead Division).



DUTCH BOY
Reg. U. S. Pat. Off.
RED LEAD

No tricks –
 No tall tales –
 No testimonials –

Just facts for architects!

There's not a word about lion hunting—and nary a testimonial—in any of American Blower's Bulletins.

But you will find them packed with authoritative data on air handling, air conditioning, heating, cooling, ventilating and allied subjects. These Bulletins have been compiled by American Blower engineers after extensive research. We believe they will save you both time and trouble.

Drop us a card today. Your selection of the five Bulletins shown, or any of our many other Bulletins, will be sent promptly without charge or obligation.

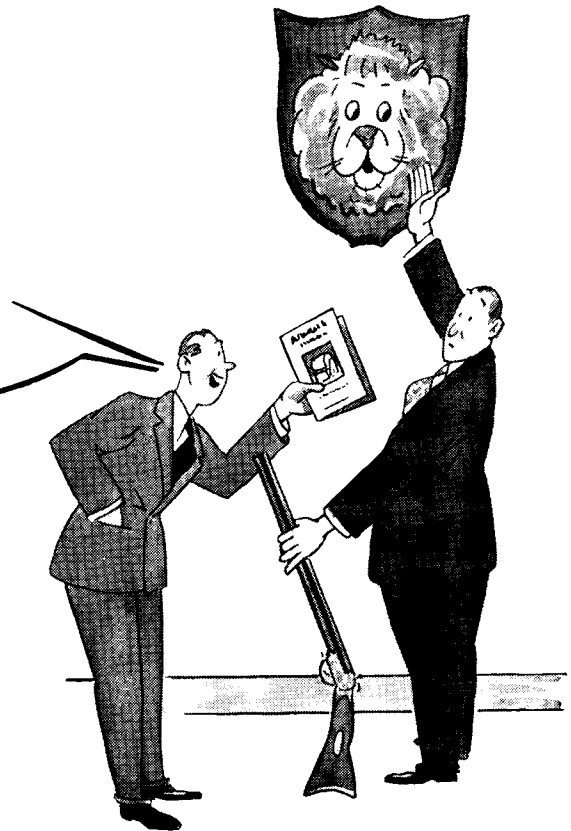

Bulletin No. 2814

Utility Sets

Ready-to-run units in standard sizes to meet a multitude of needs for electric ventilation where duct systems are required. Capacities range from 83 CFM to 17,925 CFM. Bulletin lists various size units available, outlines suggested uses, shows typical installation views—contains tables and technical data.



Bulletin No. 6927

Sprayed Coil Dehumidifiers

These units combine the washing, cleaning, dehumidifying and evaporative cooling advantages of an air washer with the compactness and simplicity of operation of surface cooling coils. One hundred twenty-seven sizes—2,310 to 45,900 CFM. Can be used with direct expanded refrigerants, chilled water, well water or brine.



Bulletin No. 5206

Industrial Fans

Type E Industrial Fans for handling air, gases, fine dust, and for conveying materials in industry, or for all types of processes, etc. Made in wide variety of arrangements for belt or direct drive as required. Also available with modifications for high temperatures and other special applications.



Bulletin No. B 813

Axial Fans

Vancaxial and Tubeaxial Fans for heating, ventilating, process work and other air handling needs. This bulletin gives complete details on construction, component parts and installation of both fans together with all necessary tables and data. Also friction and duct sizing charts.



Bulletin No. 2314

Aeropel Home Ventilators

This compact, complete unit whisks out odors, greasy fumes, smoke. Keeps kitchens fresh as a daisy. Reasonably priced, easy to install, economical to operate. Also ideal for bathrooms, bedrooms, nurseries, laundries, recreation and utility rooms, small stores and offices.

AMERICAN BLOWER

AMERICAN BLOWER CORPORATION
 DETROIT 32, MICHIGAN

In Canada: CANADIAN SIROCCO CO., LTD.,
 Windsor, Ont.

Division of AMERICAN RADIATOR & Standard Sanitary CORPORATION

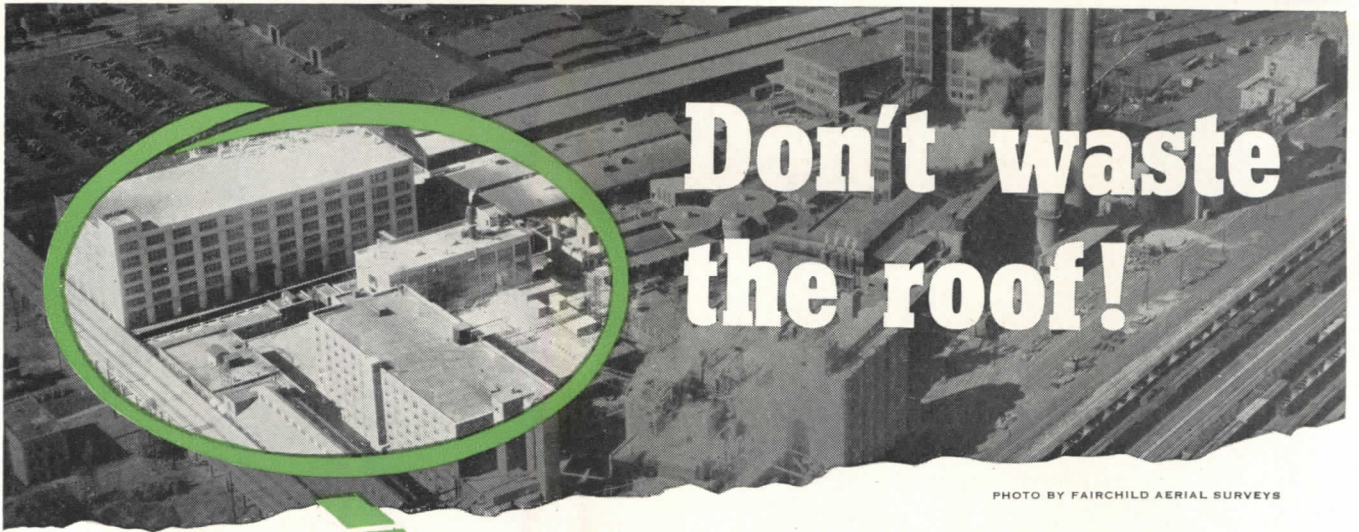

Don't waste the roof!

PHOTO BY FAIRCHILD AERIAL SURVEYS

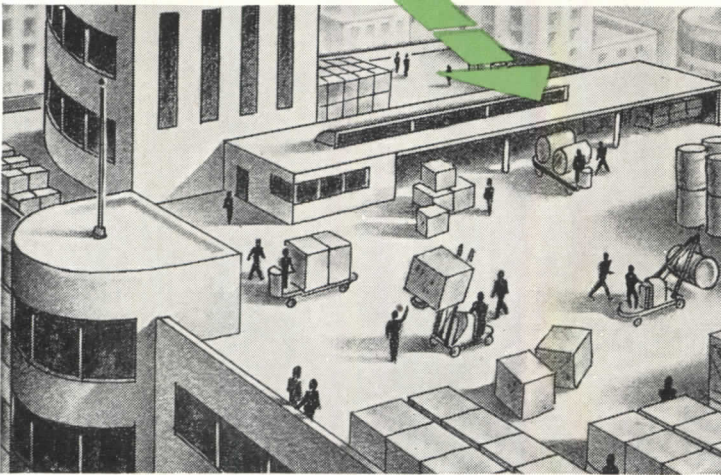

AVAILABLE NOW! NEW WAYS TO MORE EFFICIENT ROOFS!

Here's extra shipping, packing and storage space...one sample of the more productive use of roof areas made possible now by new Ruberoid specifications!

ROOFS LIKE THIS are typical of the modern, functional utilization of an area that formerly went to waste. The factory roof illustrated here has a husky concrete surface for heavy traffic and storage. Other related possibilities are hospitals with outdoor decks for convalescents, apartment houses with gardened roofs, department stores with recreational roofs for employees.

These are "roofs of the future," but recently evolved Ruberoid specifications make them completely possible *today!* As worked out by Ruberoid engineers, these new roofs are not impractical dreams, but thoroughly tested, down-to-earth cer-

tainities! Full details of these and other developments are available from the Ruberoid Company or from your local Ruberoid Approved Roofer. Call on your Ruberoid Roofer for help in the solution of any roof problem. His "know-how" is backed by Ruberoid's years of experience and complete line of all types of roofing materials!

The **RUBEROID** Co.

Executive Offices: 500 Fifth Ave., N. Y. 18, N. Y.
Asphalt and Asbestos Building Materials

The RIGHT roof for any job — from one source!



Remember that Ruberoid makes every type of built-up roof—Smooth Surfaced Asbestos, Coal Tar Pitch with gravel or slag surfacing, or smooth or gravel-and-slag surfaced Asphalt—in specifications to meet any need. Hence a Ruberoid Approved Roofer is not prejudiced in favor of any one type. His services assure you of one source for all materials, centralized responsibility, smoother operation, uniform quality!



No home owner should be left "holding the bag"!

• Architects and builders know there's no other home-heating fuel as dependable and economical as Bituminous Coal.

So even when a client of yours *insists* on some other fuel for his new home, it's wise to give him a chance to change his mind later on—and turn to coal.

Otherwise, he'll be left "holding the bag" when stoker developments, cost differentials, improved local services or other factors convince him he should heat with coal.

Just make sure his house plans include: (1) *A chimney with sufficient flue capacity to burn coal efficiently;* (2) *Sufficient space adjacent to the heating unit for eventual coal storage and stoker installation.*

These sensible precautions involve but trifling cost—and they may add greatly to the future value of a house.

Coal supplies uniform, *steady* warmth throughout every portion of each room. For there's always a fire in the furnace—no "pop on and pop off" periods that permit accumulated heat to rise to the ceilings and leave floor areas dangerously cold. That, plus its low cost, is why more than 4 out of every 7 homes in the United States now heat with coal!

BETTER AND BETTER THINGS ARE COMING FROM COAL!



As you undoubtedly know, the modern research facilities of the Bituminous Coal industry are hard at work not only to make coal a still better fuel, but also to devise new, low-cost *automatic* equipment that will make coal-heating even cleaner, more comfortable, more convenient and more economical. This makes it all the more important that every new home built today be planned to permit the eventual burning of coal—no matter what fuel may initially be selected.

BITUMINOUS COAL

BITUMINOUS COAL INSTITUTE
Washington, D. C.

Affiliate of NATIONAL COAL ASSOCIATION

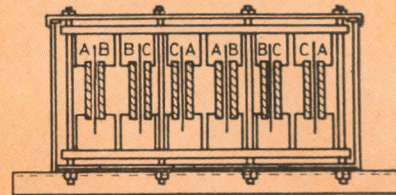
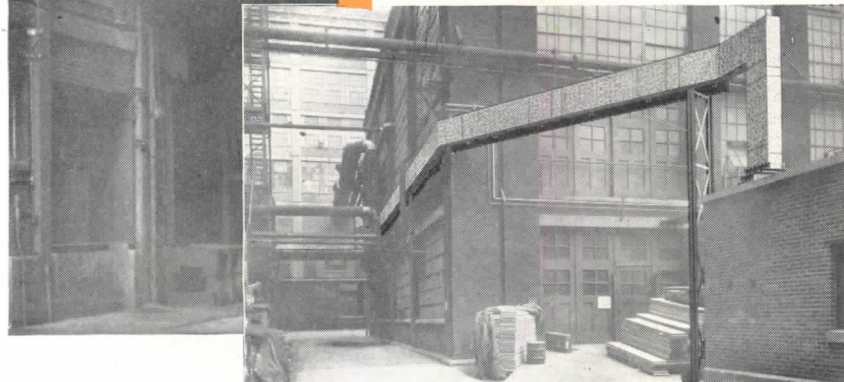
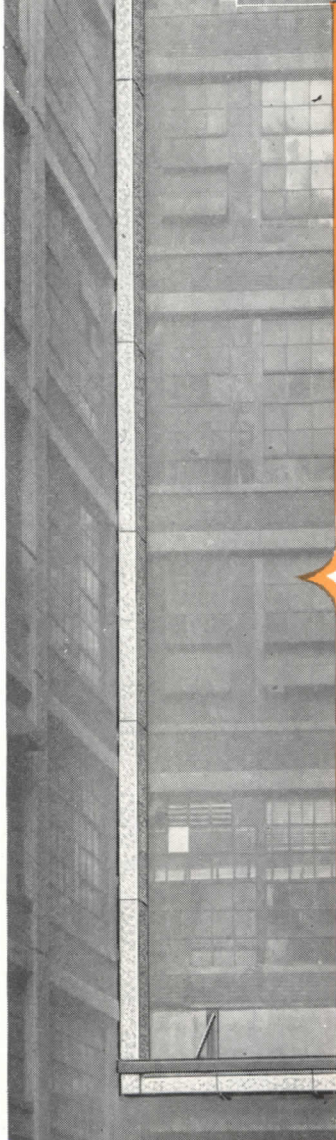



HIGH EFFICIENCY
FEEDER  BUSDUCT

High Efficiency

VENTILATED TYPE FEEDER BUSDUCT

... actual tests show less than
2 volts drop per 100 feet at
80% power factor.

Maximum efficiency is the fundamental engineering principle of the improved High Efficiency, Ventilated Type Feeder  Busduct.

Designed and built to meet today's requirements for maximum plant efficiency and productivity, Feeder  Busduct is unexcelled for the transfer of heavy current from service entrance to distribution center, from generators to switchboards or from switchboards to distribution centers. Of even greater importance is the fact that voltage loss is reduced to less than 2 volts per 100 feet at 80% power factor.

High Efficiency Feeder  Busduct is made in standard 10-foot lengths for indoor and outdoor installations. It is available in capacities from 600 to 4000 amperes, 575 volts and less.

See your nearest  District Representative for details, or write for our catalog.



Makers of

BUSDUCT SERVICE EQUIPMENT
PANELBOARDS SAFETY SWITCHES
SWITCHBOARDS LOAD CENTERS
ELECTRIC QUIKHETER

Frank Adam
ELECTRIC COMPANY
ST. LOUIS, MISSOURI

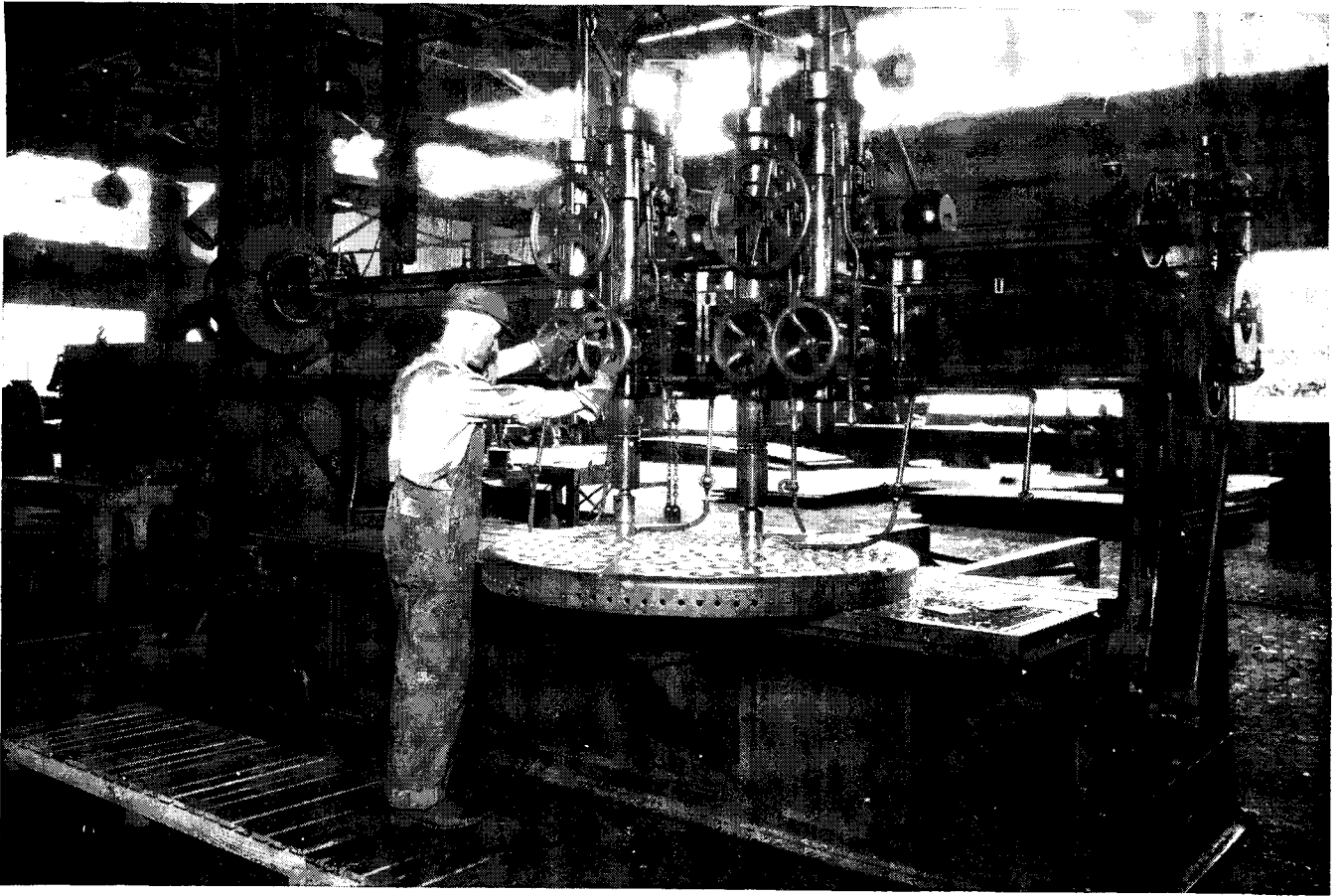

"HAND TAILORED" OF STEEL

KEWANEE

HEAVY DUTY STEEL BOILERS

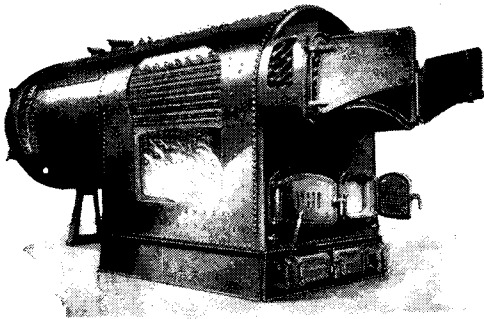

Working with the most modern machinery in America's outstanding steel boiler plant, skilled craftsmen "hand tailor" the finishing touches into Kewanee Boilers, giving them that top-degree-quality for which they have long been famous.



Reg. U. S. Pat. Off.
MEMBER

**For OIL, GAS, STOKER, or HAND FIRED
10 to 304 H.P....100, 125 and 150 lbs. W.P.**



KEWANEE BOILER CORPORATION
KEWANEE, ILLINOIS

Branches in 60 Cities—Eastern District Office: 40 West 40th Street, New York City 18

Division of **AMERICAN RADIATOR & Standard Sanitary CORPORATION**



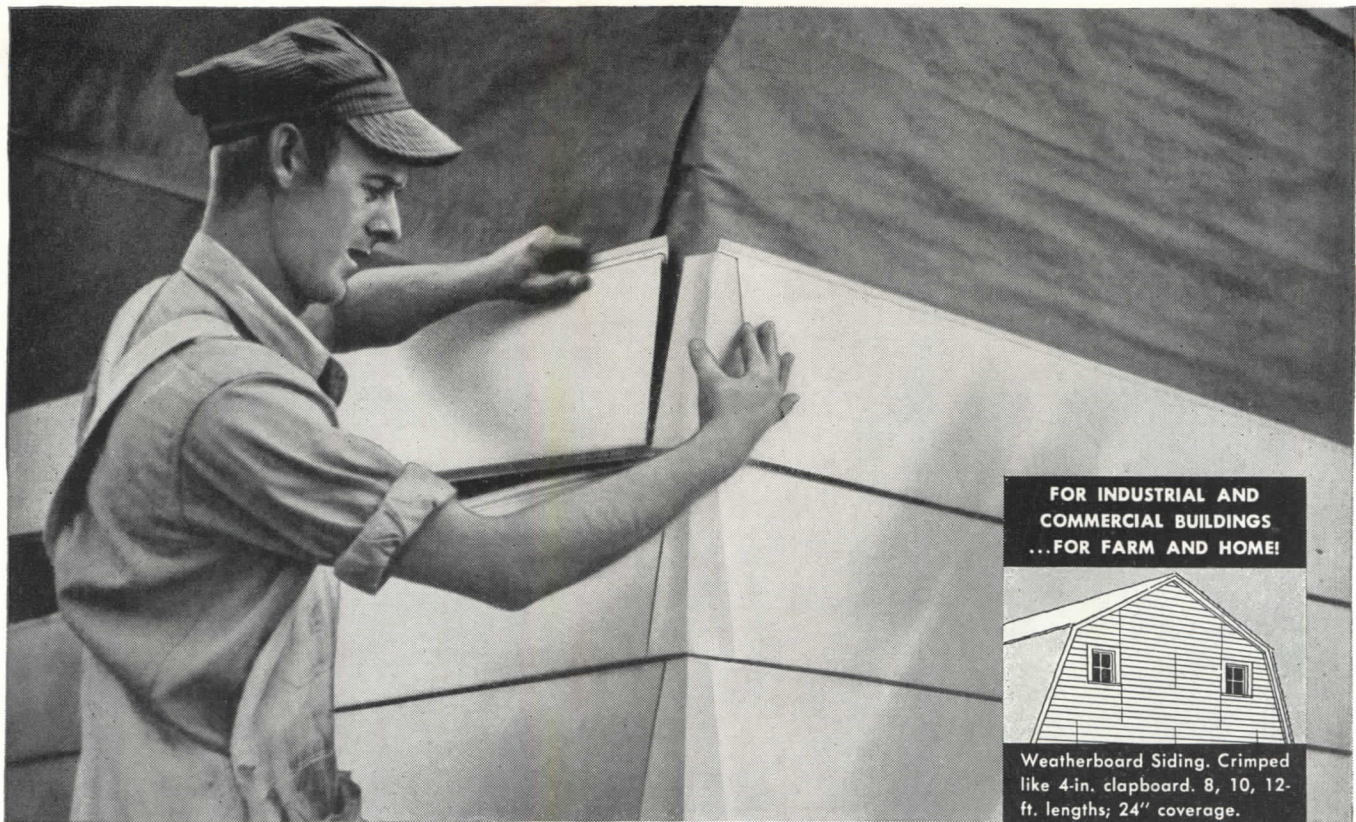

**FOR INDUSTRIAL AND
COMMERCIAL BUILDINGS
...FOR FARM AND HOME!**

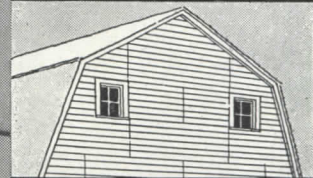

Weatherboard Siding. Crimped like 4-in. clapboard. 8, 10, 12-ft. lengths; 24" coverage.

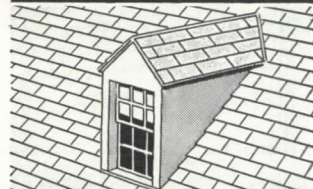

Shingles. Interlocking, weather-tight, covering all nails. Two sizes: 8x14½ and 5½x18½.



"Snap-Seal" Roofing. Sheets interlock covering all nails. 6, 8, 10, 12-ft. lengths; 24" coverage.

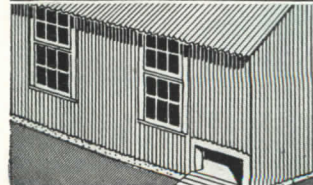

Corrugated. Extra-thick (.024"). 6, 8, 10, 12-ft.; 26" wide; 1¼-in. and 2½-in. corrugations.



5-V Crimp. Extra-thick sheets (.024"). 6, 8, 10, 12-ft. lengths; 24-in. coverage.

Who Says You Can't Get Good Siding Now?

—All you want! Shipped within 24 hours!

It could have happened to you. Many a home-planner accepted this new Reynolds clapboard to meet an emergency... then found it wasn't just a substitute, but something new and better.

Now, architects everywhere specify it for new straight-line perfection, never warping, never sagging... for lifetime permanence that defies fire, rust, rot, termites... for extra insulation through radiant heat reflection!

Builders are talking about the easy application of this light-weight, self-aligning clapboard... its snug, weather-tight fit... the simple, practically in-

visible butt joints and handsome corner finish.

Your supplier can take advantage of quick deliveries and low price on mixed carload orders. But time's a-wasting! National advertising and promotion is building demand among your own clients. Write, wire or phone for detailed literature... offices in principal cities. Reynolds Metals Company, Building Products Division, Louisville 1, Kentucky.



REYNOLDS *Lifetime* ALUMINUM BUILDING PRODUCTS

ALSO: ALUMINUM STUDS, TRUSSES, WINDOW FRAMES, GARAGE DOORS, REFLECTIVE INSULATION AND COMPLETE ALUMINUM HOUSES.

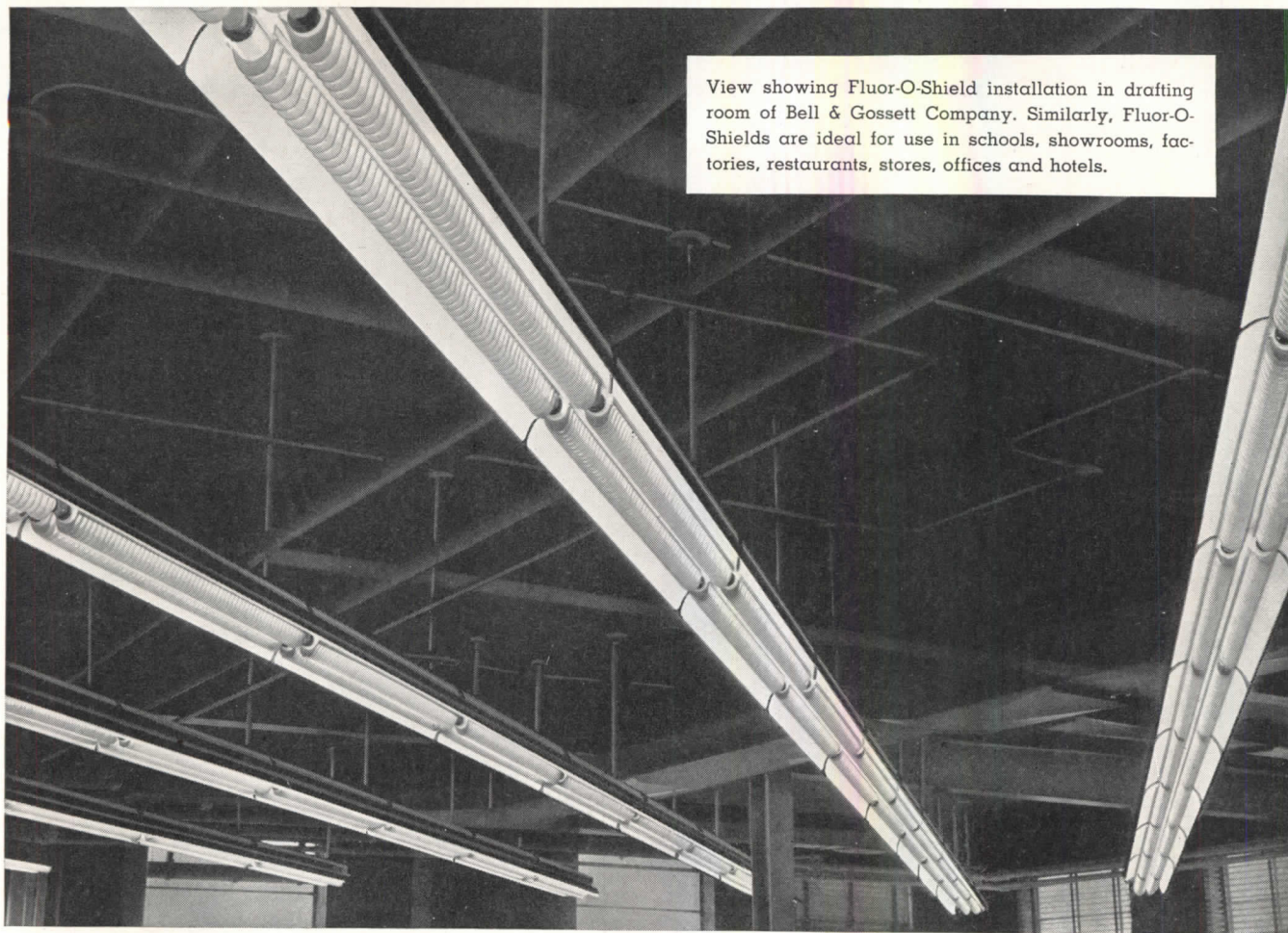

View showing Fluor-O-Shield installation in drafting room of Bell & Gossett Company. Similarly, Fluor-O-Shields are ideal for use in schools, showrooms, factories, restaurants, stores, offices and hotels.

Bell & Gossett Company rid their drafting room of glare this inexpensive way



No trick to install Fluor-O-Shields. Just snap them on. No bolts or tools needed. No flat surfaces to catch dust or dirt.

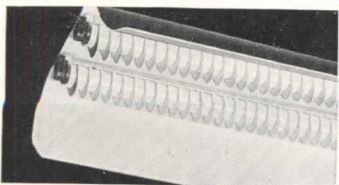

3 sizes to fit most exposed lamp fixtures. For continuous or unit mounting. 92% of the light and none of the glare.

Light weight, ease of attachment and all around efficiency make Fluor-O-Shields the most practical light diffuser on the market.

"Our lighting situation was improved greatly after we had installed fluorescent lighting fixtures. But then we had a glare problem to deal with. We found the most efficient and inexpensive answer in Fluor-O-Shields. They have proved very satisfactory and our employees are all highly pleased with the results."

Bell & Gossett Company, Morton Grove, Illinois

Bell & Gossett Company, manufacturers of hot water heating equipment, have installed 2-tube 40-watt standard industrial reflector fixtures, butted end-to-end. Fixtures are placed 9'6" from the floor where they furnish an even intensity of light at working level. Approximately 220 Fluor-O-Shields have been installed in this room. This is the most practical and economical way known to get efficient lighting with the least amount of glare. Fluor-O-Shields are endorsed by lighting engineers, lamp tube manufacturers and electrical testing laboratories for use wherever good lighting is essential to better working conditions. For more data, specifications and information, write to address below.

THREE SIZES

\$1⁹⁵	40 watt 46 ⁷ / ₈ inch	NEW!	\$2⁹⁵	100 watt 58 ¹ / ₈ inch
	20 watt 22 ⁷ / ₈ inch			

Aluminum finished in white baked enamel

FLUOR-O-SHIELD*

Light Diffuser for Fluorescent Lamps

*Trade Mark — Patent Pending.

CAMFIELD MANUFACTURING COMPANY • GRAND HAVEN, MICHIGAN

How to meet a specific window need - Economically

SELECT FROM THE NEW STANDARDIZED FENCRAFT WINDOWS

CASEMENT . . . PROJECTED . . . COMBINATION

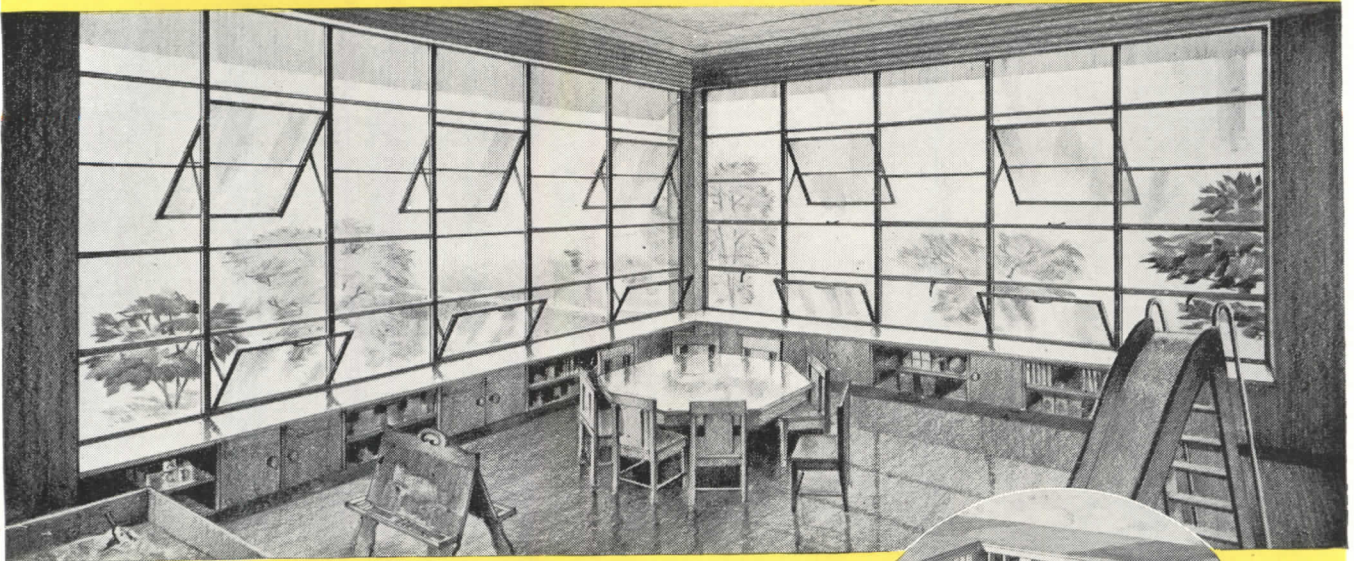

A school's kindergarten room, for example, needs ample daylight for young eyes . . . with windows low so youngsters can see out . . . with abundant fresh-air ventilation . . . with all vents so designed that when open the children cannot fall out of windows.

Such windows are offered in the three new lines of Fencraft units which provide new high quality, lower cost and important installation economy.

Built of specially-designed steel casement sections, by craftsmen in the shops of America's oldest and largest steel window manufacturer, all Fencraft Windows beautify both the outside and the inside. They provide permanently easy operation, safe cleaning, lasting weather-tightness, firesafety and low maintenance cost.

For singular economy in cost, all types and sizes are standardized. And installation cost is minimized by the use of uniform installation details, plus the co-ordination of window dimensions with those of wall materials.

Eminently suited for America's finest buildings, including schools, Fencraft Windows are now being shipped to many localities. For product details, see Fenestra's catalog in Sweet's for 1947 (Section 16a-9). Or mail coupon below.



Suggestion:

In a school's kindergarten room, combine units of Fencraft Standard Intermediate Projected Windows, such as type 416 (illustrated). Note that sill vents, opened, guard against drafts, prevent children from falling out.

Fenestra

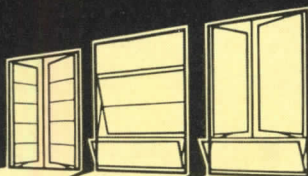

FENCRAFT INTERMEDIATE STEEL WINDOWS

Detroit Steel Products Company
Dept. 2252-AR-5
2250 East Grand Blvd.,
Detroit 11, Michigan

Please send me data on types and sizes of the new Fencraft family of Fenestra Windows:

Name _____

Company _____

Address _____

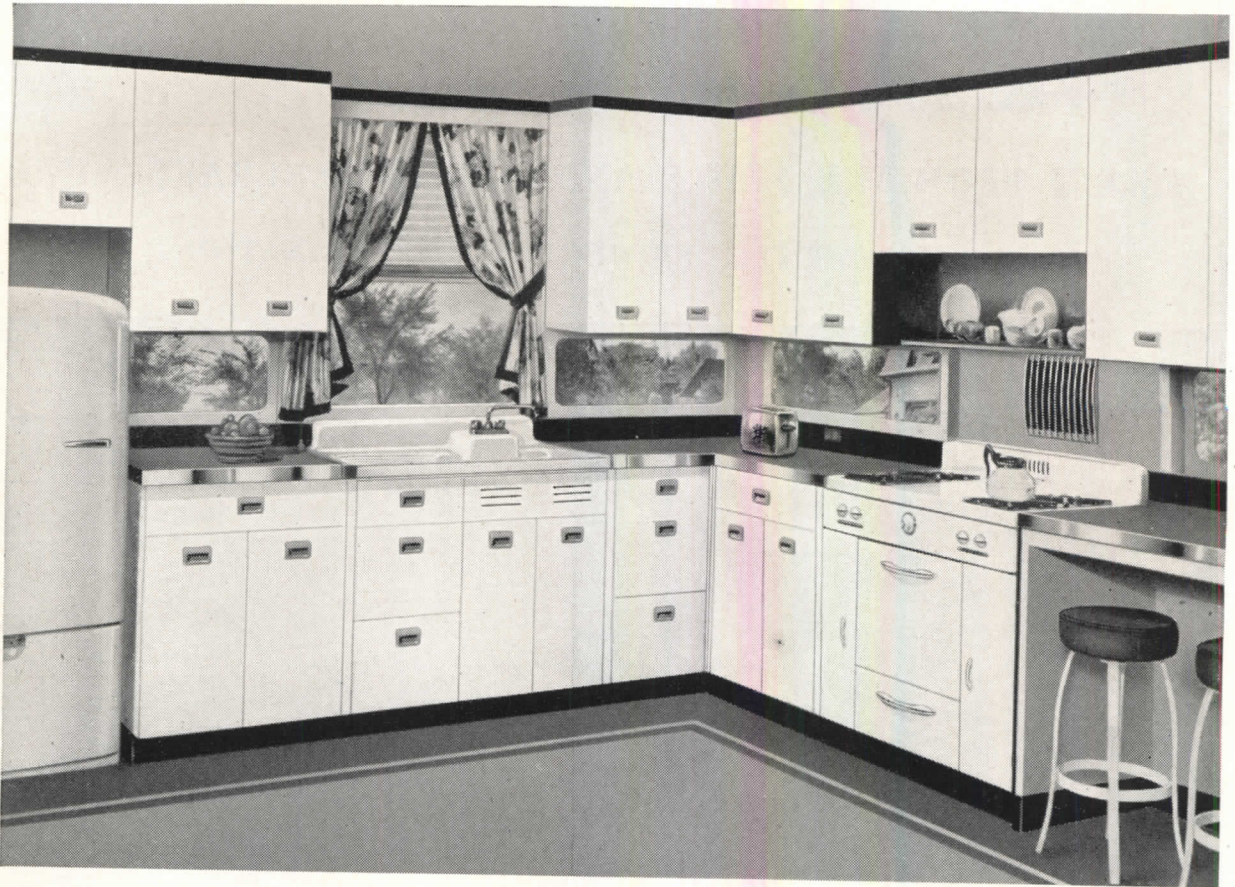

The Crane Stewardess Kitchen

CRANE PLUMBING and HEATING ... for the homes you are planning

There's no surer bet for client approval than the words, "Plumbing and Heating by Crane." Nation-wide surveys show more people know Crane than any other name in plumbing.

Crane's 1947 line includes kitchen sinks, bathroom groups, laundry tubs—a size and style for every plan—a price for every budget. This is the finest line Crane has ever produced.

In heating, too, Crane offers home planners

equipment for every type system—steam, hot water or warm air. Here you will find a complete range of boilers and furnaces to meet every fuel requirement—coal, coke, oil, or gas. Included also are radiators, convectors, controls, pipe, valves and fittings.

Refer to your copy of the recently published "Crane Service for Architects." If you have not received a copy, call your Crane Branch for one.



Approx. Size: 13' 11" x 10' 3"

Shown at the left is a floor plan of the kitchen illustrated above. The Crane Stewardess Sink can, of course, be used in smaller kitchens as suggested in the two layouts at the right.



Approx. Size:

11' 0" x 7' 4"



Approx. Size:

10' 10" x 6' 11"

CRANE

NATION-WIDE SERVICE THROUGH BRANCHES, WHOLESALERS, PLUMBING AND HEATING CONTRACTORS

CRANE CO., GENERAL OFFICES:
836 S. MICHIGAN AVE., CHICAGO 5
VALVES • FITTINGS • PIPE
PLUMBING AND HEATING

A. W. FABER'S **CASTELL** LOCKTITE

the professional man's
refill drawing pencil which
embraces 7 exclusive features

for drawing
sketching
retouching

CLEAN—No need to touch the lead and get graphite particles or dust on your fingers or smudges on your drawing. Hold point to paper, press button, lead can be adjusted by upward or downward movement of hand.

NON-BREAKAGE—An unusually fine precisioned collet supports the graded lead all the way around and prevents it from breaking or snapping off under greater than normal pressure during the pointing or sanding process or when in actual use.

NON-SLIPPAGE—The same precision collet holds the lead in a bulldog grip. Lead positively cannot slide back into the holder.

QUICK—Just press your thumb on the button release. Eliminates two-hand screwing or turning operation.

STURDY—Finest quality plastic and metal used in every part, exposed metal parts gold plated, all expertly assembled.

BALANCED—Every part is well proportioned giving you a drawing instrument which is perfectly balanced in your hand.

GUARANTEED—If your Castell Locktite does not perform perfectly, return it to your dealer or to us for exchange immediately.

Holds all standard makes of refill graded drawing and retouching leads. We recommend WINNER Techno-TONE 1930.

only \$1 at your Art Supply House, Drawing Material Dealer, Blue Printer, Stationer or Photographic Supply Shop.

A.W. FABER INC.
NEWARK, N. J.



Shown Above: Bigelow Gropoint—Lokweave Construction—12 Colors

Plans for the future call for **CARPETS BY BIGELOW**

If your future plans call for the design or redesign of interiors, then the choice of the right carpet becomes a lively issue.

Bigelow puts expert advice and years of experience at your service. See the large selection of patterns and colors, earmarked for weaving

during 1947 and 1948. Let a Bigelow contract specialist assist you to choose the right carpet for the right spaces.

You may have to wait for the carpet you want, but Bigelow can help you with your special planning requirements now.



BIGELOW-SANFORD CARPET CO., INC. • 140 Madison Ave., New York 16, N. Y.

BUILDING? MODERNIZING? PARTITIONING?

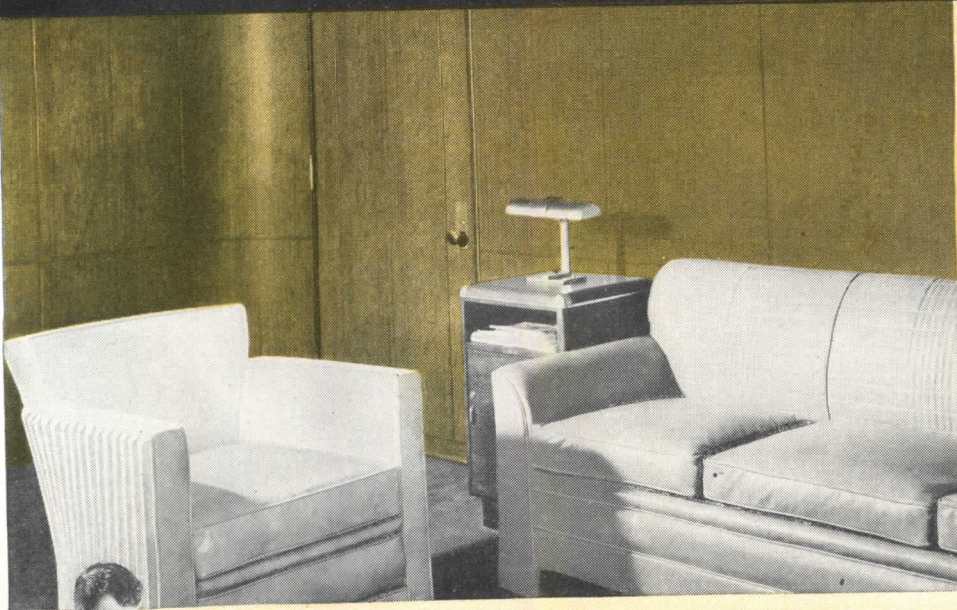

See this 10 minute demonstration

**Here's a Newer,
Better Way
to Divide Space**

By use of a few standardized parts and fittings, M/P Metlwals meet every wall paneling and partitioning requirement . . . eliminate the need for plaster in new construction . . . and permit fast, clean, simple installation in dividing space. They combine rich beauty, quiet and fire resistance with low initial cost and permanent economy.

PRE-FABRICATED . . . PRE-DECORATED

Made in lifelike wood grains and soft color finishes . . . providing an all-flush surface from floor to ceiling . . . eliminating the need for filler boards of other materials at ends or above the cornice level . . . M/P Metlwals of Bonderized steel make possible an endless variety of new, modern decorative effects. And you can use these distinctive interiors for executive, factory and general offices, stores, banks, theatres, hotels, hospitals, schools, residences and other buildings of every kind.

WRITE OR PHONE FOR DEMONSTRATION

The nearest M/P Distributor listed at the right is ready to give you a 10 minute demonstration of the unique features of M/P Metlwals. Write or phone him today. Also, for your A. I. A. file, send for booklet No. 35-H-6, containing Metlwal specifications, drawings and installation photographs. Address: Martin-Parry Corporation, Fisher Bldg., Detroit 2, Michigan. Plants: Toledo, Ohio; York, Pennsylvania.

**CALL YOUR NEAREST
M/P DISTRIBUTOR**

- ALABAMA**
- Birmingham.....Acousti Engineering Co.
- Mobile.....Acoustics & Specialties Co.
- ARKANSAS**
- Little Rock.....Acoustics & Specialties Co.
- CALIFORNIA**
- Los Angeles.....The Harold E. Shugart Co.
- Oakland.....F. K. Pinney, Inc.
- Sacramento.....F. K. Pinney, Inc.
- San Francisco.....F. K. Pinney, Inc.
- COLORADO**
- Denver.....Lauren Burt, Inc.
- CONNECTICUT**
- Hartford.....The C. A. Bader Co.
- DELAWARE**
- Wilmington.....John H. Hampshire, Inc.
- Wilmington (Eastern Shore).....The W. M. Moyer Co.
- DISTRICT OF COLUMBIA**
- Washington.....John H. Hampshire, Inc.
- FLORIDA**
- Jacksonville.....Acousti Engineering Co.
- Miami.....of Fla.
- Pensacola.....Acoustics & Specialties Co.
- GEORGIA**
- Atlanta.....Acousti Engineering Co.
- ILLINOIS**
- Decatur.....Hugh J. Baker & Co.
- INDIANA**
- Evansville.....Hugh J. Baker & Co.
- Fl. Wayne.....Hugh J. Baker & Co.
- Indianapolis.....Hugh J. Baker & Co.
- Wabash.....Hugh J. Baker & Co.
- KENTUCKY**
- Louisville.....E. C. Decker & Co.
- LOUISIANA**
- New Orleans.....Acoustics & Specialties Co.
- MAINE**
- Portland.....Pitcher & Co.
- MARYLAND**
- Baltimore.....John H. Hampshire, Inc.
- MASSACHUSETTS**
- Boston.....Pitcher & Co.
- Springfield.....The C. A. Bader Co., Inc.
- MICHIGAN**
- Detroit.....R. E. Leggette Co.
- Grand Rapids.....Leggette-Michaels Co.
- MINNESOTA**
- Minneapolis.....Insulation Sales Co., Inc.
- MISSOURI**
- Kansas City.....Henges Co., Inc.
- St. Louis.....Henges Co., Inc.
- NEW JERSEY**
- Elizabeth.....Jacobson & Co.
- Trenton.....The W. M. Moyer Co.
- NEW MEXICO**
- Albuquerque.....The Jay Grear Corp.
- NEW YORK**
- Albany.....Collum Acoustical Co.
- Buffalo.....Collum Acoustical Co.
- Jamestown.....Collum Acoustical Co.
- Rochester.....Collum Acoustical Co.
- Syracuse.....Collum Acoustical Co.
- New York City.....Jacobson & Co.
- NORTH CAROLINA**
- Charlotte.....Acousti Engineering Co. of the Carolinas
- OHIO**
- Akron.....Mid-West Acoustical & Supply Co.
- Cleveland.....Mid-West Acoustical & Supply Co.
- Columbus.....Mid-West Acoustical & Supply Co.
- Toledo.....Mid-West Acoustical & Supply Co.
- Cincinnati.....E. C. Decker & Co.
- Dayton.....E. C. Decker & Co.
- PENNSYLVANIA**
- Altoona.....Harry C. Leezer Co.
- Pittsburgh.....Harry C. Leezer Co.
- Sharon.....Harry C. Leezer Co.
- Harrisburg.....The W. M. Moyer Co.
- Philadelphia.....The W. M. Moyer Co.
- Seranton.....The W. M. Moyer Co.
- RHODE ISLAND**
- Providence.....Pitcher & Co.
- SOUTH CAROLINA**
- Charleston.....Acoustic Engineering Co. of the Carolinas
- SOUTH DAKOTA**
- Sioux Falls.....Insulation Sales Co., Inc.
- TENNESSEE**
- Chattanooga.....Len Herndon Co.
- Knoxville.....Len Herndon Co.
- Nashville.....Len Herndon Co.
- Memphis.....Acoustics & Specialties Co.
- TEXAS**
- Dallas.....S. W. Nichols Co.
- Houston.....S. W. Nichols Co.
- San Antonio.....S. W. Nichols Co.
- El Paso.....The Jay Grear Corp.
- UTAH**
- Salt Lake City.....Lauren Burt, Inc.
- VIRGINIA**
- Norfolk.....John H. Hampshire, Inc.
- Richmond.....John H. Hampshire, Inc.
- Roanoke.....John H. Hampshire, Inc.
- WEST VIRGINIA**
- Huntington.....E. C. Decker & Co.
- Clarksburg.....Harry C. Leezer Co.
- Wheeling.....Harry C. Leezer Co.
- WISCONSIN**
- Milwaukee.....Edw. T. VerHalen, Inc.
- WYOMING**
- Cheyenne.....Lauren Burt Inc.

MARTIN PARRY
MP
PRODUCTS

METLWALS ALL-FLUSH PANELING
MOVABLE PARTITIONS

ENGINEERING AND ERECTING SERVICE AND
WAREHOUSE STOCKS FROM COAST-TO-COAST

67 Years of Service

PETRO OIL HEAT...

"A part of Good Store Planning"

RETAIL STORES differ widely — from the small compact one-floor establishment to the huge multi-floor enterprise occupying an entire city block.

Yet both benefit from the same dependable, low-cost heat when Petro equipment is installed. For stores, as for apartments, one-family homes, bakeries, laundries and even large manufacturing plants, Petro Oil Burners can be specified to serve any heating load, utilizing light fuel or, where batteries of large boilers are operated, heavy commercial oil.

As Mr. Morris Ketchum, Jr. puts it, "Petro systems meet all these requirements... are a part of *good* store planning."

Petro Oil Burner Systems provide many significant benefits. Supervision on the part of the janitor or building custodian is held to a minimum. Fuel is economized through high combustion efficiency. Dust and noise are eliminated, thereby improving customer shopping conditions in basement stores. Costly furnace maintenance is avoided.

Whether you are designing a store or other building, you and your client will find that Petro Oil Burning equipment means low-cost, high-efficiency heating year after year.

INDUSTRIAL MODELS: No. 5 or No. 6 fuel oil; manual, semi- or automatic operations; 8 sizes up to 450 bhp. Thermal Viscosity preheating.

DOMESTIC MODELS: No. 3 or lighter oils; "conversion" and combination-unit types, 7 sizes. Patented "Tubular Atomization."

FULL DATA on Petro Industrial Burners are in catalog files of Sweet's and Domestic Engineering. Details on Petro Domestic Burners available in separate catalog. Copy of either sent gladly on request.



Morris Ketchum, Jr., of the firm of Ketchum, Gina and Sharp, New York Architects, is well-known as a designer of many outstanding buildings and as an expert on store planning. Included in his work are Florsheim Shoe Store for Women, Ciro of Bond Street, Lederer de Paris, Artek-Pascoe, and America House, all in New York City.

PETRO

REG. U. S. PAT. OFF.

cuts steam costs

PETROLEUM HEAT AND POWER CO. • *Makers of Good Oil Burning Equipment Since 1903* • Stamford, Connecticut



**It's Easier to
Get Things Done
in the Shade!**

**Insure Increased Efficiency and
More Pleasant Summer Living
in Light, Cooler Rooms . .**

Specify **KOOLSHADE^{*} SUN SCREEN**

No Loss of Light . . . No Glare . . . Clear Vision!

Sun-drenched rooms can be comfortably cool, shaded and light! Actual cases in every section of the country—in factories, homes, public buildings—prove that KoolShade blocks and radiates up to 90% of the sun rays *outside the window*, cuts temperatures as much as 15 degrees, lets in an abundance of clear, glareless light and gives unobstructed vision.

KoolShade is in effect a miniature outside venetian blind. Paper thin bronze "slats" are permanently set at a 17° slant . . . blocking sun's heat rays outside the window. It frames and installs as simply and neatly as ordinary insect screen—that's real double-duty efficiency.

Air Conditioned Rooms . . . are kept cooler at less cost in KoolShade equipped buildings because KoolShade reduces the Sun Heat Load on glazed openings, 80 per cent to 85 per cent—thus cutting equipment and operating costs.

KoolShade preserves . . . the smart architectural lines of modern building design—no projecting hardware is necessary, no adjusting and practically no maintenance. For economical "sun-conditioning" specify KoolShade Sun Screen.

WHY YOU SHOULD SPECIFY KOOLSHADE!

- *Easy and inexpensive to install—will not rust, rot or rattle.*
- *Permanently adjusted for greatest shading efficiency.*
- *Prevents fading of valuable drapes and furnishings.*
- *Fits neatly and smoothly into modern architectural design.*
- *Durable bronze KoolShade also effective as insect screen.*

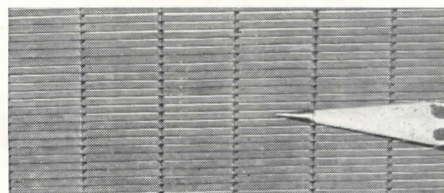

Outdoors the sun "sees" the flat of the slats like this—sun heat rays just can't get in.

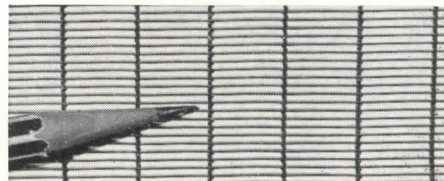

Indoors only the paper thin edges are seen—you get a clear, unobstructed view.

**Tear Out and Mail This Coupon
for Cool Shaded Comfort This Summer!**

Ingersoll Steel Division
Borg-Warner Corp., Dept. M5
310 South Michigan Ave., Chicago 4, Ill.

Please send free sample and literature, also the name of my nearest KoolShade distributor.

Name

Firm

Address

City State



Ingersoll
KOOLSHADE^{*} SUN SCREEN

*Trade Mark
Property of **INGERSOLL STEEL DIVISION · BORG-WARNER CORPORATION**

New Detroit schools use advanced

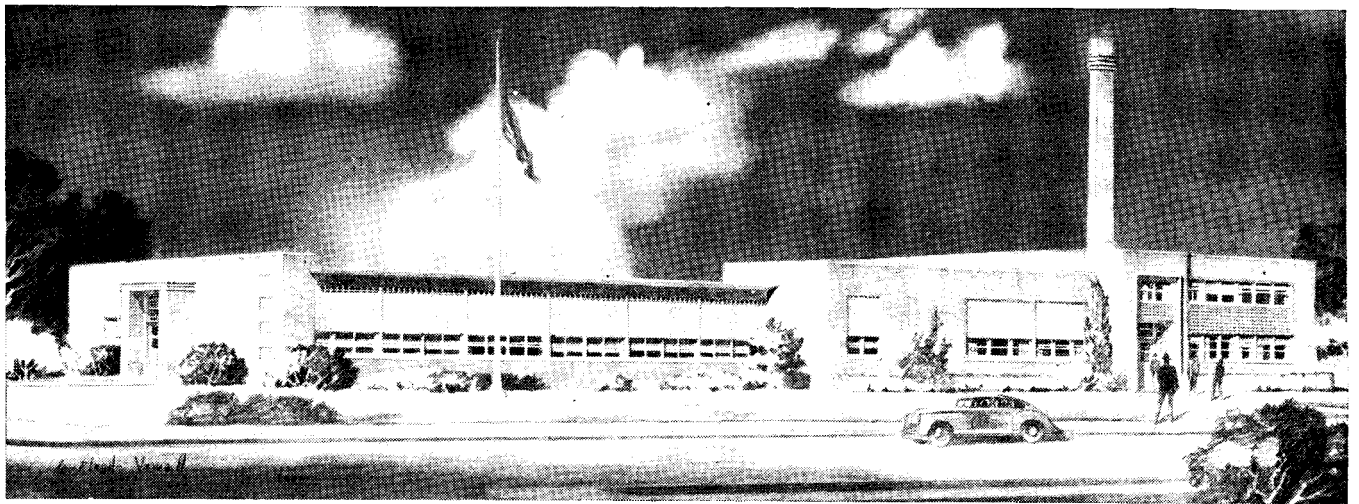

*Ann Arbor Trail Elementary School
N. Chester Sorensen Company
Joseph Peter Jagerst, Architects and Engineers*

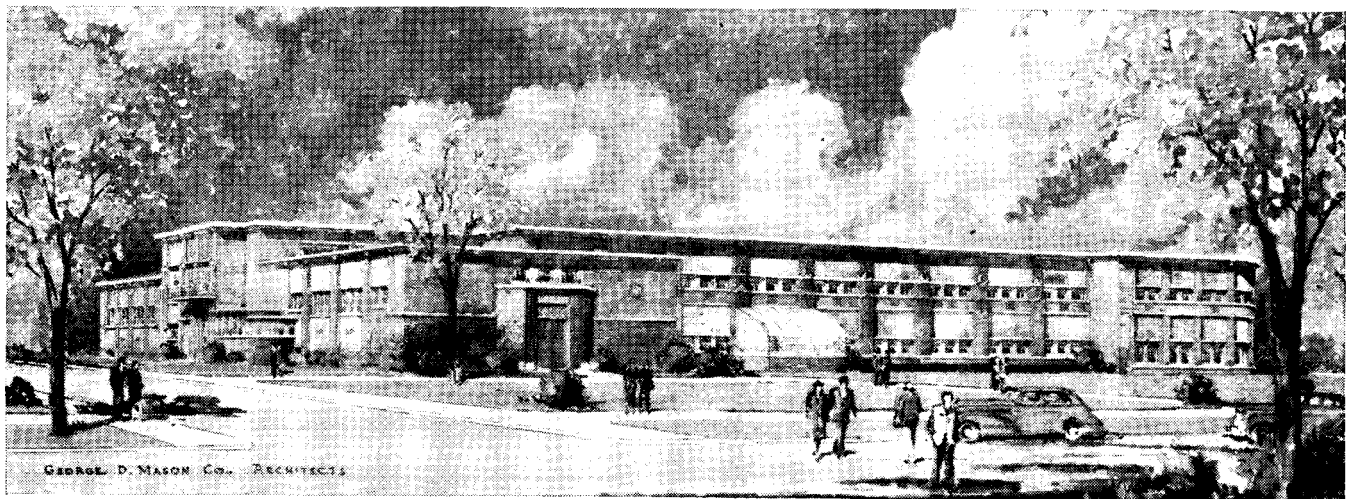

*Dr. Zina Pitcher Elementary School
Geo. D. Mason & Co., Architects*



*James Vernor Elementary School
Eberle M. Smith Associates, Architects-Engineers*

methods to insure quality lighting

More Uniform Task Brightnesses Throughout Classrooms —Lower Brightness Contrasts in Child's Field of Vision Made Certain by Scientific Use of Daylight

NEW and improved methods of using daylight for classroom lighting are being built into a group of new schools in the City of Detroit. Designs are by some of the leading architectural firms in Detroit under the supervision of G. L. Schulz, Director of Building, Detroit Board of Education.

Low Brightness Contrasts. In the schools pictured here and in others still in various stages of design, the brightness of the light-transmitting source has been reduced and the effectiveness of the light source has been retained through scientific direction of daylight.

The result is less interfering brightness to be tolerated and higher brightnesses above eye line to be utilized—a higher ratio of useful brightness to tolerated brightness. This means lower contrasts than are typically found in schools—the lowest contrasts that have yet been obtained through daylight utilization—approximating those recommended by lighting authorities.

Predictable Task Brightnesses. Through the medium of prismatic glass block, daylight is transmitted into the classroom and redirected upward toward the ceiling and upper half of the room. Task brightnesses near the window are reduced. Task brightnesses farthest from the windows are increased. Diversity in task brightness from desk to desk across the room is reduced.

And the actual results are now predictable. It is possible to design a school classroom with prismatic glass block and forecast task brightnesses, wall and ceiling brightnesses and brightnesses of the fenestration itself for any condition of outside lighting.

Visible areas of bright sky are greatly reduced and dependence on manual regulation of light-transmitting areas is minimized.

To make the job complete these new schools are employing up-to-date techniques in artificial lighting and interior decoration and treatment. Scientific use of daylight does not minimize the need for good artificial lighting or good interior treatment. Furthermore, the new principles of lighting employed in these schools have been adapted to well recognized and well established standards of classroom design.

The result is good functional architecture—planned to give the child the best seeing environment possible, and to secure all that good lighting can contribute to his health and educational growth.

Insulux prismatic block No. 351 has been developed for accurate daylight control. The pattern, utilizing the four faces of the block, turns light upward. The ceiling acts as a huge reflector to re-direct light downward.

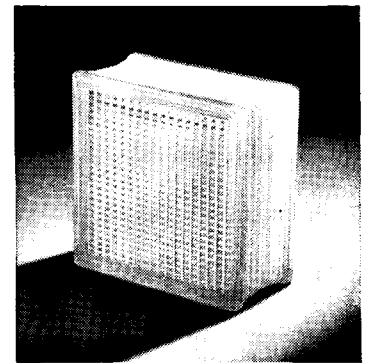

Now Available for the First Time . . .

New Comprehensive Data on Daylight Applied to Classroom Design

Anyone familiar with the problems of daylight use will recognize the accompanying predictions of daylight utilization in these schools as little short of revolutionary.

These are not just pleasing generalities. All of these factors of quality lighting have been measured and evaluated by recognized lighting authorities. The background information has been correlated and adapted to standard classroom design by the Owens-Illinois Glass Company.

Almost all of this information is original unpublished work, now available for the first time. It will give the architect the design data he needs, and will answer a multitude of questions on interior brightnesses and brightness contrasts. This information will be sent in reply to your letter, or, for convenience, use the coupon.

OWENS-ILLINOIS GLASS COMPANY,
Insulux Products Division, Dept. D-5
Toledo 1, Ohio

Gentlemen:

Please send me information on school lighting.

Name _____

Address _____

City _____ Zone _____ State _____

OWENS - ILLINOIS
INSULUX
GLASS BLOCK

NO 40-HOUR WEEK



FOR AN
Automatic
OTIS ELEVATOR

AN OTIS COLLECTIVE CONTROL ELEVATOR on the job is your clients' assurance of fast, reliable elevator service 168 hours a week, 52 weeks a year!

Because an Otis elevator, when properly maintained, will give dependable, trouble-free service for the life of a building.

Whether it's an apartment house, hospital, small hotel or office building — whether it's still in the blueprint stage or due for improvements — an Otis Full Collective Control elevator will help make it truly modern. Here's why:

OTIS FULL COLLECTIVE CONTROL ELEVATORS

1. Never waste time, never forget, never make mistakes.
2. Can be operated by either passengers or an attendant.
3. Have doors that open and close automatically.

In each of our 245 local offices are experienced elevator men ready to serve you now and your client in the future.



**ELEVATOR
COMPANY**

OFFICES IN
ALL PRINCIPAL CITIES



*When in New York,
visit the Curtis Wood-
work display at Archi-
tects' Samples Corpora-
tion, 101 Park Avenue.*

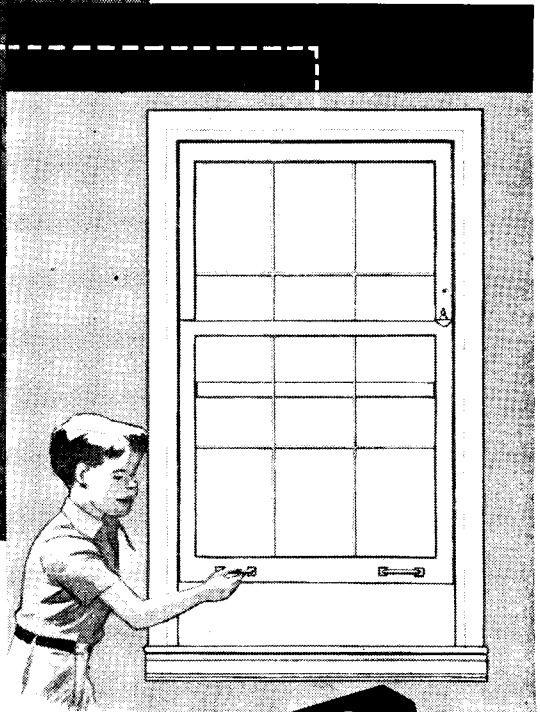

It "FLOATS"

YET IS ALWAYS

WEATHER SEALED

new self-fitting SILENTITE

Design a window so easy to operate that it actually seems to "float" . . . yet which is constantly sealed against air infiltration . . . far more weathertight than ever before.

That is the problem which Curtis engineers solved in the new self-fitting Silentite. Famous Silentite spring suspension creates a window that even a child can easily open. Yet the full length double-Z type bronze weather-strips in the jambs press sliding bars against the edges of the sash, providing a constantly tight fit. This new type weather-stripping, plus improved weather-stripping at head, sill and meeting rail, makes the new self-fitting Silentite fully 20% more weathertight even than the original Silentite window introduced by Curtis in 1932.

Silentite windows are made of wood—because Curtis has found wood to be the most completely satisfactory of all window materials. Yet Silentite windows have the streamlined appearance that fits today's idea of window beauty. Let us tell you all about the new self-fitting Silentite and its new achievements in window design.



Curtis Companies Service Bureau
AR-58 Curtis Building, Clinton, Iowa
Gentlemen: Please send booklets on the new Curtis
Woodwork and the new Silentite Window.

Name.....

Address.....

City..... State.....

I am Architect, Contractor, Prospective
Home Builder, Student

(Please check above)

"No noise, no wear"

GIVES TENANTS AND OWNERS

BIG FROZEN FOOD LOCKER

Servel's big, convenient Frozen Food Locker stores up to 60 packages of frozen meats, poultry, vegetables, fruits, biscuits. It saves housewives hours of shopping time.

MOIST COLD, DRY COLD

Garden vegetables and fruits stay fresh and appetizing in Servel's big dew-action fresheners, and meat keeps tender for days in the Servel meat keeper.

NO NOISE, NO WEAR

There's no machinery to cause noise or wear in the famous Servel Gas Refrigerator. Not a single moving part in its freezing system. Thus, Servel stays silent, lasts longer.

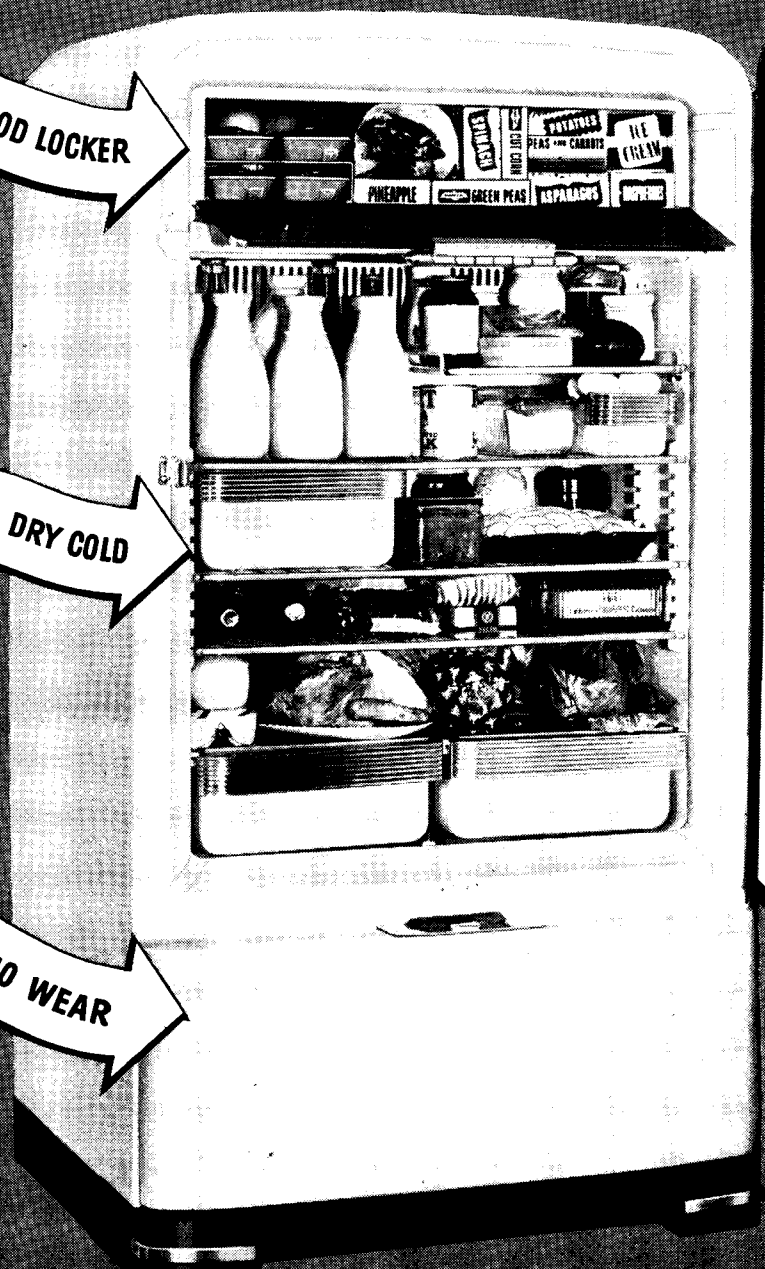

STAYS SILENT
LASTS LONGER

Servel The GAS

Refrigerator

GREAT NEW FEATURES FOR 1947

• As more than 2,000,000 Servels have proved, this modern Gas Refrigerator provides noise-free, dependable operation throughout its long life. Now the great new 1947 Serval offers even more—a host of new features that insure the finest in modern food storage.

The new 1947 Serval contains a big Frozen Food Locker that stores up to 60 packages of frozen foods. With it, homemakers can plan varied and delightful menus every season of the year. In addition, the 1947 Gas Refrigerator provides moist cold and dry cold, a new flexible interior adjustable to eleven positions, rust- and scratch-resistant Plastic Coated shelves and many other big new conveniences tenants will appreciate.

Offers Silence and Dependability, Too

Of course, the Serval Gas Refrigerator is still permanently silent, lastingly dependable. Serval's unmatched performance throughout the war has demonstrated to owners that the Gas Refrigerator stays on the job year after year. Operating and maintenance costs remain low. That's because the freezing system of Serval is different from all others. It has no machinery, no moving parts to get noisy, none to wear or break down.

So for the tops in food storage, plus silent, dependable performance, specify the great new 1947 Serval Gas Refrigerator for the apartment buildings and homes you design, build or manage. Plan now to provide outlets for Gas Refrigeration in your current designs and construction work. For installation data and complete information on the new 1947 Serval Gas Refrigerator, consult Sweet's Builders' File. Or write today to Serval, Inc., Evansville 20, Indiana.

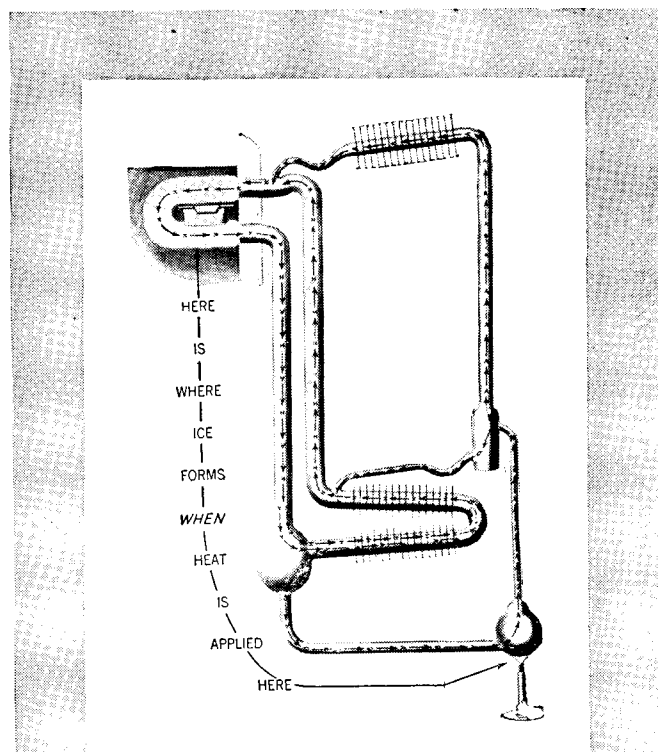

Here's why Serval stays silent, lasts longer

Serval's simpler method of operation is the result of its basically different freezing system. The Gas Refrigerator operates on the continuous absorption principle of refrigeration. In a Serval, the refrigerant is hermetically sealed in a set of vessels connected by pipes. A tiny gas flame is applied to the lowest vessel. Owing to the evaporation properties of the refrigerant and the law of gravity, ice forms in an upper vessel. No machinery—motor, valves, pumps or compressors—is needed. Serval has no moving parts in its freezing system. Thus, it stays silent, lasts longer.

Refrigerator

You'll build or
remodel better with
Gold Bond



*A house is no better
than its sheathing...*

**AND NO SHEATHING IS
BETTER THAN THIS!**



ONE important contribution to better construction is Fireproof Gold Bond Gypsum Sheathing with the new asphalt treated core. The big rock-like panels are now supplied with surfaces, edges, and even the gypsum rock center thoroughly processed with a water-repellent treatment. Insures full protection against moisture and all kinds of weather. In these times of hurried production,

one consideration of utmost importance to architects and builders is *uniform quality*. With Gold Bond Gypsum Sheathing there is no such thing as unseasoned or "green" material—no danger of expansion or contraction. Every panel is absolutely uniform as to size, thickness and quality.

Gypsum Sheathing insures great structural strength and provides

permanent fire protection for the wood framing. The big panels—2' x 8'—can be applied in a lot less time than narrow strips of old style sheathing. Fewer joints, too, and these are wind-tight because of snug-fitting T and G edges.

You'll find Gold Bond Gypsum Sheathing described in detail in our section in Sweet's. The cost? Less than old style inflammable sheathing.

NATIONAL GYPSUM COMPANY • BUFFALO 2, N. Y.

Over 150 Gold Bond Products including gypsum lath, plaster, lime, wallboard, gypsum sheathing, rock wool insulation, metal lath products and partition systems, wall paint and acoustical materials.

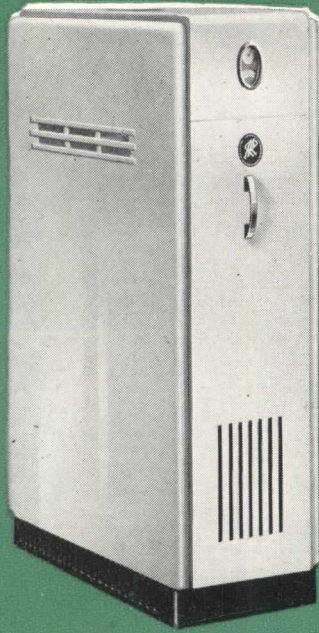

**RICHMOND
HEATOMAT
GAS BOILER**

Richmond Heatomat Gas Boiler—Sizes from 64,800 to 2,880,000 Btu output. For hot water, steam and vapor systems. Also gravity furnaces and winter air conditioners.

Servilla Enameled Cast Iron Sink—One of the extensive Richmond line of fine enameled ware—bathtubs, lavatories, sinks, sink-and-trays.

Bromley Vitreous China Lavatory—A modern shelf-type lavatory of pleasing design. Richmond produces vitreous china fixtures of the highest quality, including lavatories, water closets and urinals.



**SERVILLA ENAMELED
CAST IRON SINK**

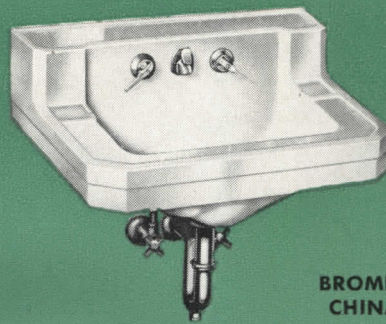

**BROMLEY VITREOUS
CHINA LAVATORY**

**FOR
VISIBLE VALUES
... SPECIFY
RICHMOND**

RICHMOND plumbing and heating equipment gives your client full value that's readily *visible*. Its high quality is evident at a glance. For example, all Richmond home heating gas boilers have a baked-on Dulux enamel finish in lustrous white, yet are moderately priced.

Richmond's well-packaged units help keep installation costs down, require less servicing. All Richmond gas heating units have AGA approval *plus* a one-year replacement guarantee. All Richmond plumbing fixtures bear the one-year guarantees recommended by the National Bureau of Standards.

Delivery *now* on most Richmond products.

For complete details, see your plumbing and heating contractor or write Richmond Radiator Co., Dept. AR-5, 19 E. 47th Street, New York 17, N. Y.



RICHMOND RADIATOR COMPANY
Affiliate Reynolds Metals Co.

Enameled Cast Iron Ware • Vitreous China • Perma-Gloss • Gas Gravity Furnaces • Gas Winter Air Conditioners • Gas Boilers • Radiators

Royal Barry Wills designs a house ...



Mesker Metal Casements

“Metal windows go well with almost every style of residential architecture. Their simplicity and slender lines add charm to both traditional and contemporary design.”

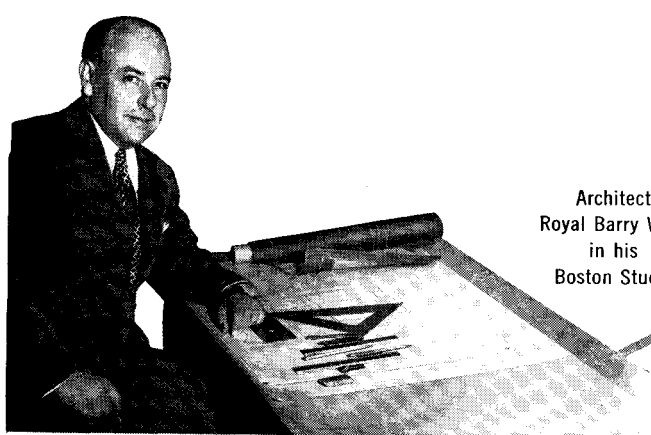

Architect
Royal Barry Wills
in his
Boston Studio

For your copy of the Mesker Book of Windows for Homes, write to Mesker Bother, 4338 Geraldine Ave., St. Louis 15, Mo.

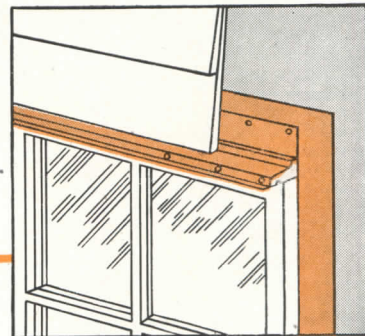
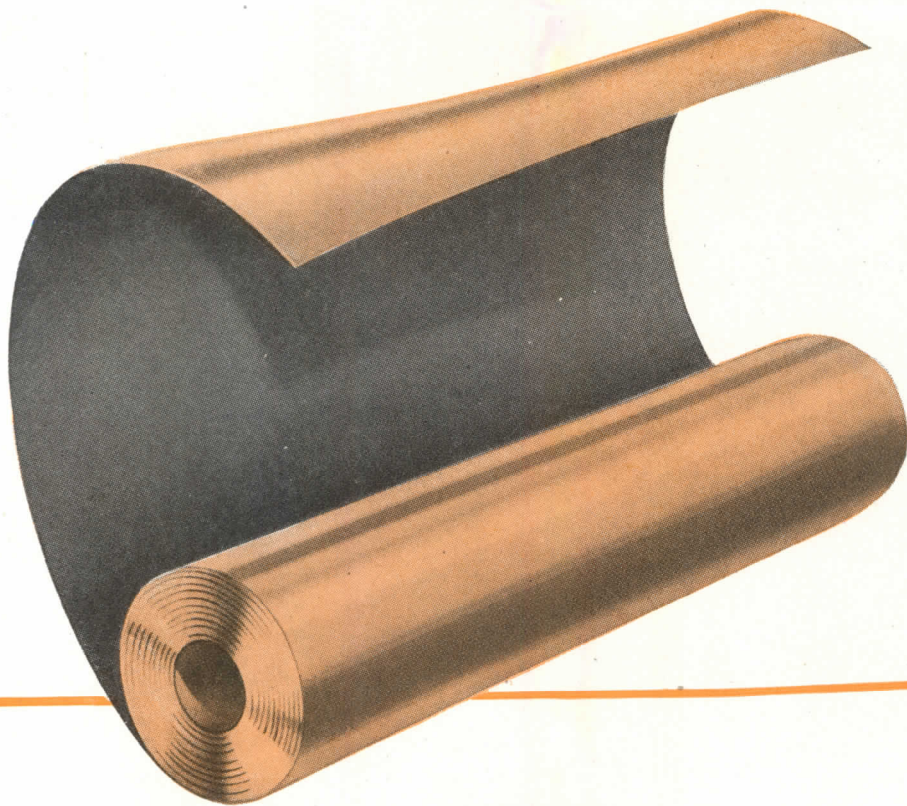

"Electro-Sheet"

an outstanding material for concealed flashing applications

Anaconda "Electro-Sheet" is pure copper formed in thin sheets by an exclusive process of electro-deposition. The resultant product has been widely used for water-proofing and damp-proofing because of these salient features:

Produced in weights of 1, 2 and 3 oz. per square foot.

Non porous; water-tight and air-tight.

Made in wide, continuous lengths, (width up to 60").

Can be bonded firmly to high-grade building papers; available in this form from several manufacturers.

Also available coated both sides with special asphaltic compound.

Flexible, easy to handle, form and apply.

Moderate in price, since it makes a little copper go a long way.

In addition to the window flashing, illustrated,

"Electro-Sheet" is extensively and successfully used for spandrel beam flashing, as a foundation damp course between masonry and sills, as a damp course between sheathing and brick veneer, as a vapor seal for insulation, as flashing for roof ridges, in forming water-tight pans for shower stall floors, and in other concealed flashing applications. Further information in Sweet's, 1946, 8C-1. 4718

ANACONDA
From mine to copper

Anaconda

COPPER

THE AMERICAN BRASS COMPANY

General Offices: Waterbury 88, Connecticut

Subsidiary of Anaconda Copper Mining Company

In Canada: ANACONDA AMERICAN BRASS LTD.,

New Toronto, Ont.



(Left) Typical richly decorated display room. Note conditioned air supply grille below frieze. Western Air & Refrigeration, Inc., designed and installed the system.



(Below) Marble and polished black granite façade of the store, built by William Simpson Construction Co., Los Angeles.

Styled for Shopping in Comfort . . .

AIR CONDITIONED WITH "FREON" SAFE REFRIGERANTS

When more than eight years ago the luxurious, completely air conditioned I. Magnin store was opened in Los Angeles, California, thousands welcomed a new shopping center which, today, is still an outstanding example of modern classic architecture . . . smartly styled for the comfort of customers and the store personnel.

In designing the structure, Myron Hunt and H. C. Chambers, architects of the building, and Timothy L. Pflueger, architect of the interiors, predicated their plans upon air conditioning throughout.

All six floors of the store, including offices and work rooms, are conditioned with thirteen cooling units installed in ceiling spaces. These use chilled water provided by five 40-ton

Westinghouse compressors located with the balance of the refrigerating plant in the central equipment room in the basement. "Freon" refrigerants are used exclusively because they are safe, non-toxic, non-flammable and highly efficient.

The equipment is controlled by thermostats and maintains a steady supply of cool and clean fresh air that (to quote store officials): ". . . makes shopping and working in Magnin's a pleasure even on the hottest day. The system has been very satisfactory . . . has required no major repairs since installation and the safety factors make it ("Freon-12") a most desirable refrigerant."

Fine architectural structures entirely air conditioned with "Freon" may be seen in almost every city in

the country . . . a tribute to the performance of these safe and dependable refrigerants. Your clients will appreciate your recommendation of modern, compact, space-saving equipment designed to utilize "Freon" refrigerants. Kinetic Chemicals, Inc., Tenth and Market Streets, Wilmington 98, Del.







**Greatest Wall Beauty!
Lowest Wall Upkeep!**



VARLAR STAINPROOF WALL COVERING

This is "June Rose," one of 90 lovely patterns and solid tones which will be increasingly available this spring.

Yes, you get maximum beauty *plus* lowest maintenance cost with this miracle wall covering. Because Varlar's *practical* beauty resists many injurious elements which would destroy ordinary wall coverings...resists ever-present finger marks  and beauty-effacing pencil and ink marks . Add to the countless enemies of beauty which Varlar defies . . . dirt abrasion . . . water . . . lipstick . . . perfume . . . piping hot kitchen grease  . . . steam . . . vermin  . . . and bacteria. None of these can mar the beauty of Varlar!

Looks NEW After 25,000 Washings!

The above staining agents—AND STAINS OF ALL KINDS—easily, quickly wash clean from Varlar with ordinary soap and water. Wash clean as many as 25,000 times without dimming Varlar's original good looks! But read the proof of performance—the complete story of this amazing wall covering which begins a new era of low-cost wall beauty and maintenance. Mail the coupon below for your free copies of factual, impartial laboratory reports by independent testing laboratories.

**Now in Production!
Send for
facts today!**

Never Before Such Enduring Beauty

VARLAR
Stainproof Wall Covering

VARLAR, Inc., Division of **UNITED WALLPAPER** Merchandise Mart, Chicago 54, Ill.

VARLAR, INC., Dept. 136-547
Merchandise Mart, Chicago 54, Illinois

Please send me, without cost or obligation, the complete independent test reports on Varlar.

Name

Address

City..... State.....

Now Gutter Linings Can Give EXTRA YEARS OF SERVICE

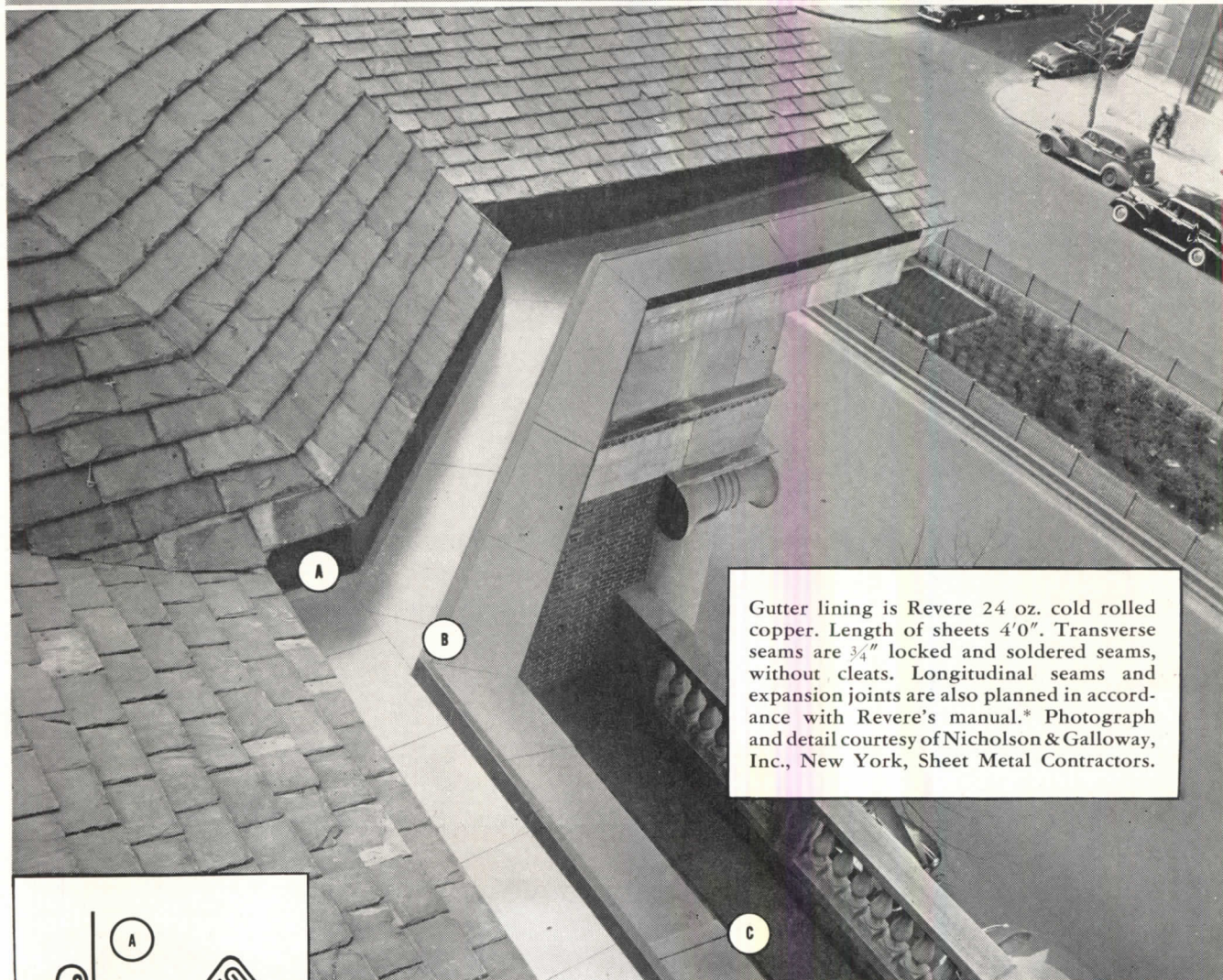

Gutter lining is Revere 24 oz. cold rolled copper. Length of sheets 4'0". Transverse seams are $\frac{3}{4}$ " locked and soldered seams, without cleats. Longitudinal seams and expansion joints are also planned in accordance with Revere's manual.* Photograph and detail courtesy of Nicholson & Galloway, Inc., New York, Sheet Metal Contractors.

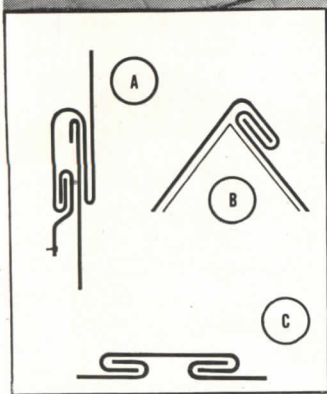

● Of all the commonly used sheet metals, copper is the most enduring when exposed to the elements. And now, as a result of Revere's research, important new facts are available which enable you to design or install copper gutter linings, flashings and roofs that give extra years of service.

This research has clearly proved that control of three fundamental factors will insure long-service copper installations. They are (1) weight and temper of the copper, (2) design and distribution of expansion joints and (3) strength of transverse joints. Observation of only one or two of these factors may lead to premature stress failures. When all three are controlled maximum length of service is assured.

The findings of this study have been compiled into a 96-page booklet.* It is complete with charts and

detailed information so arranged that you can read and apply final figures that insure the finest sheet copper construction.

This book has been widely distributed to architects and sheet metal contractors, and in all probability is in your office files. Be sure to refer to it. If you do not have a copy, write for one now on your office letterhead. If you wish further information, the Revere Technical Advisory Service, Architectural will be glad to help you.

*"Research Solves Problems of Stress Failures in Sheet Copper Construction."

REVERE

COPPER AND BRASS INCORPORATED

Founded by Paul Revere in 1801
230 Park Avenue, New York 17, New York
Mills: Baltimore, Md.; Chicago, Ill.; Detroit, Mich.; New Bedford, Mass.;
Rome, N. Y.—Sales Offices in Principal Cities, Distributors Everywhere.

Jenkins PRACTICAL PIPING LAYOUTS 22

How to plan MEDIUM and LOW PRESSURE DISTRIBUTION from a HIGH PRESSURE STEAM PLANT

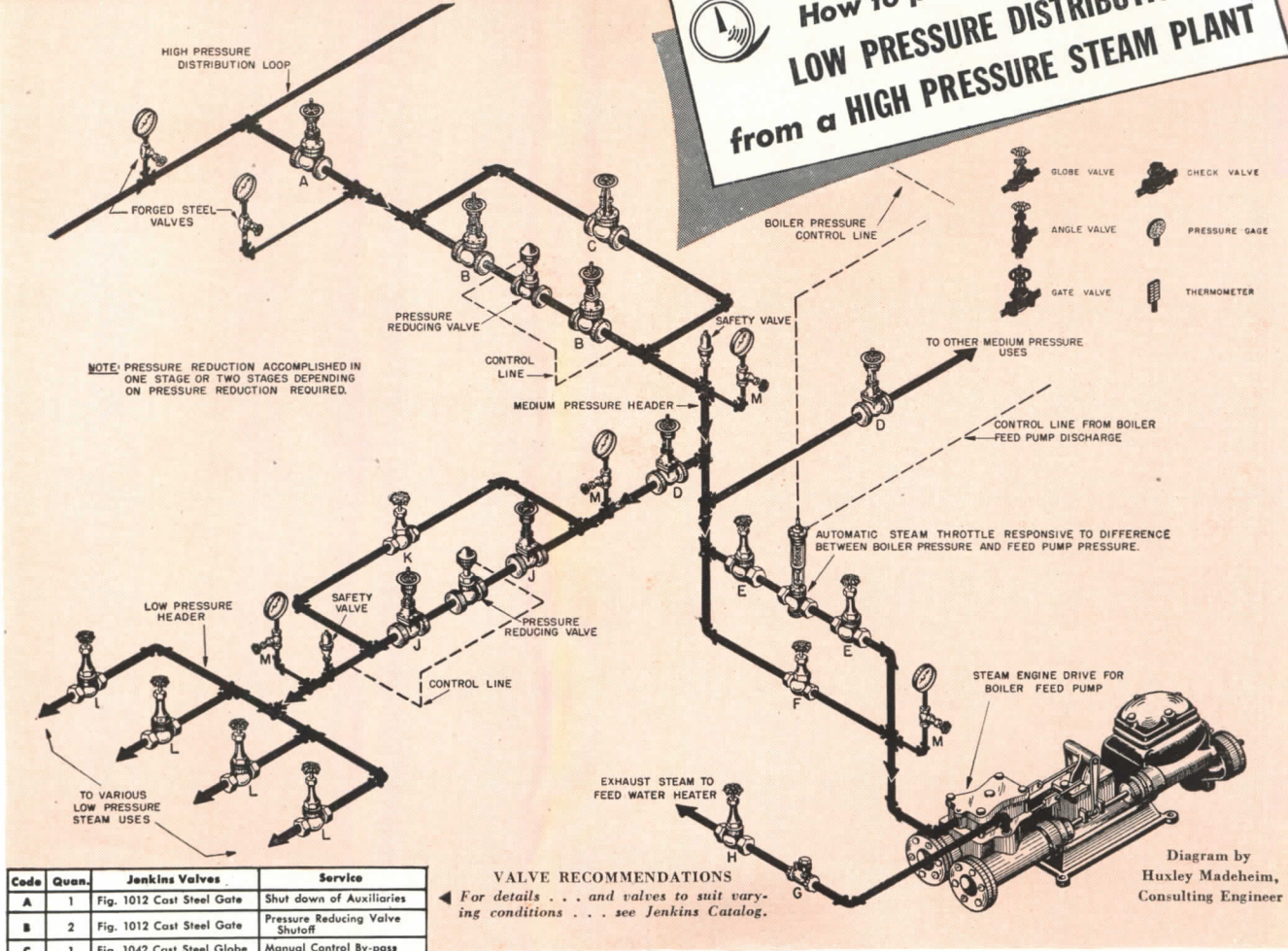

Code	Quan.	Jenkins Valves	Service
A	1	Fig. 1012 Cast Steel Gate	Shut down of Auxiliaries
B	2	Fig. 1012 Cast Steel Gate	Pressure Reducing Valve Shutoff
C	1	Fig. 1042 Cast Steel Globe	Manual Control By-pass
D	2	Fig. 253 I.B.B.M. Gate	Individual System Shutdown
E	2	Fig. 49 Bronze Gate	Automatic Throttle Shutoff
F	1	Fig. 106-A Bronze Globe	Manual Control By-pass
G	1	Fig. 92 Bronze Swing Check	Back flow check
H	1	Fig. 47 Bronze Gate	Steam Engine Exhaust
J	2	Fig. 253 I.B.B.M. Gate	Pressure Reducing Valve Shutoff
K	1	Fig. 106-A Bronze Globe	Manual Control By-pass
L	4	Fig. 47 Bronze Gate	Individual Shutdowns
M	4	Fig. 106-A Bronze Globe	Pressure Gage Control

VALVE RECOMMENDATIONS
 For details . . . and valves to suit varying conditions . . . see Jenkins Catalog.

Diagram by
 Huxley Madeheim,
 Consulting Engineer

● When steam is generated at high pressure, provision must usually be made for medium and low pressure steam distribution. For example, steam generated at 450 p.s.i. might be reduced to 100 p.s.i. for the operation of steam driven auxiliaries, and further reduced to 5 p.s.i. for heating purposes. The diagram shows a typical pressure reduction hookup.

The two pressure reducing stations are identical in layout. Each is provided with a pressure reducing valve good for dead end service, gate valves for shut-offs, and globe valves in the by-passes. Pressure gauges are installed on both the high and low side, and a safety valve on the low side guarantees against the possibility of pressure-reducing valve failure. Where large reductions in pressures are required, two stages are often recommended, with reducing stations duplicated completely.

The boiler feed pump steam engine drive is controlled responsive to boiler feed line pressure, and a manual by-pass around the control valve is provided.

Copies of Layout No. 22, enlarged, with additional information, will be sent on

request...also future Piping Layouts. Just mail coupon.

Other types and pressure ranges of Jenkins Valves can be used for this layout, according to factors involved. Consultation with accredited piping engineers and contractors is recommended on major installations.

A CHOICE OF OVER 600 JENKINS VALVES
 To save time, to simplify planning, to get the advantages of Jenkins specialized valve engineering experience . . . select all valves from the Jenkins Catalog. Jenkins Valves assure lowest cost in the long run.

Jenkins Bros., 80 White St., New York 13; Bridgeport, Conn.; Atlanta; Boston; Philadelphia; San Francisco; Chicago. Jenkins Bros., Ltd., Montreal.

LOOK FOR THIS  DIAMOND MARK
 Since *Jenkins Bros* 1864

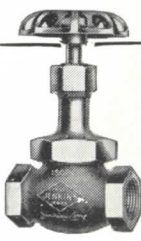

JENKINS VALVES

For every Industrial, Engineering, Marine, Plumbing-Heating Service . . . in Bronze, Iron, Cast Steel, and Corrosion-resisting Alloys . . . 125 to 600 lbs. pressure.

Sold Through Reliable Industrial Distributors Everywhere

JENKINS BROS., 80 White St., New York 13, N. Y.
 Please send me a reprint of Piping Layout No. 22 and future Layouts as they become available.

Name.....
 Address.....
 Company.....

INDUSTRY PLANS AHEAD *with* CLAY PIPE



BESIDES helping to speed construction in today's booming industrial expansion, Clay Pipe is one of the most important factors in guarding against future plant obsolescence. Today's new factory may change over in a few years to metal pickling, chemical processing or some other manufacturing activity requiring the disposal of strong acid wastes. Where Clay Pipe is specified, such a change will cause no disposal system difficulties. Clay is the *only* pipe that can safely carry all industrial wastes and sewage without decomposing, corroding or rusting. It is the one pipe that is both chemical and abrasion-proof. It always pays to specify "Clay" . . . the pipe you can put down to *stay!*

For information on your Clay Pipe problem, write to the closest regional office listed below.

NATIONAL CLAY PIPE MANUFACTURERS, INC.

571 Chamber of Commerce Bldg., Los Angeles 15, Calif.

522 First National Bank Bldg., Atlanta 3, Ga.

1105 Huntington Bank Bldg., Columbus 15, Ohio

111 W. Washington St., Chicago 2, Ill.

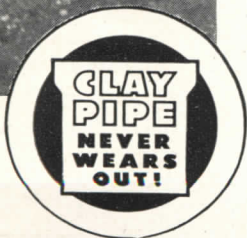

CLAY PIPE

C-447-1

ANEMOSTAT...



a name
you can proudly
add to yours

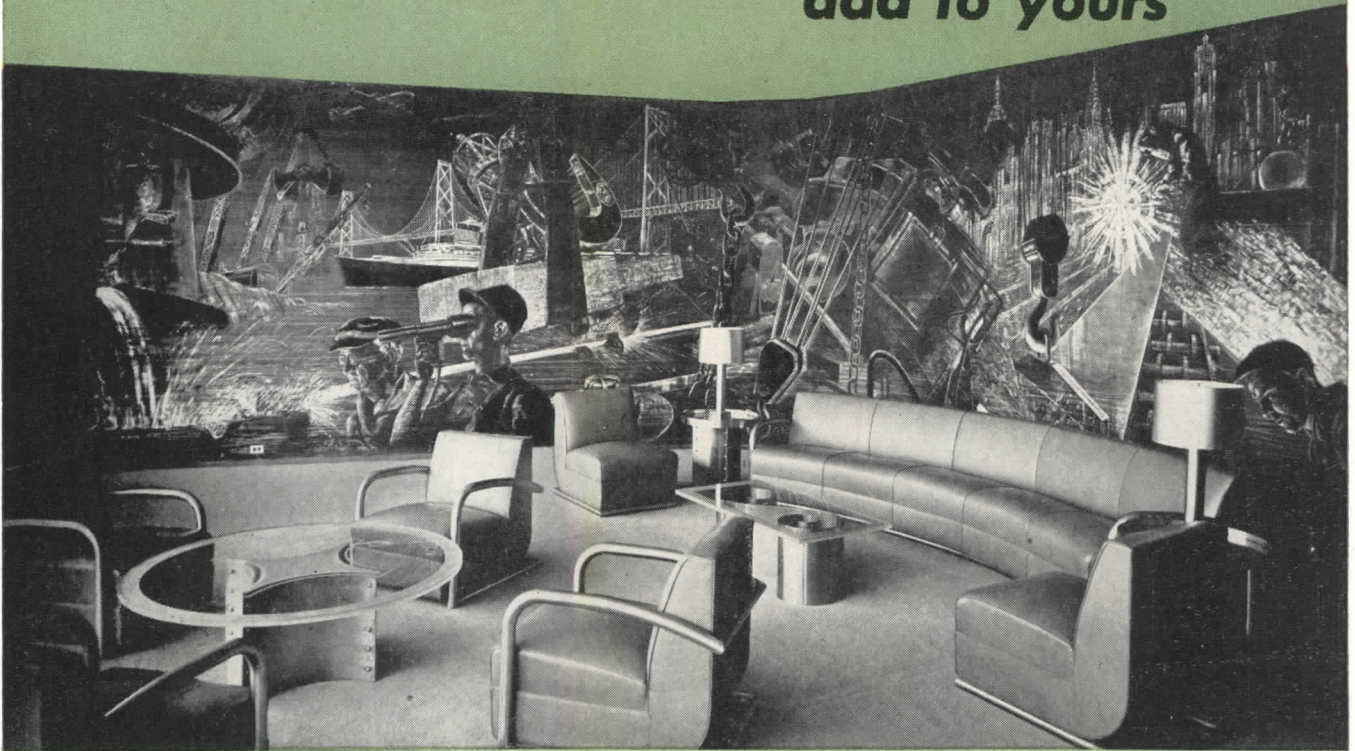

Anemostat is an air-conditioning name which every architect, engineer or contractor can proudly associate with his own. For Anemostat air-diffusion successfully completes the actual purpose of air-conditioning — true air-comfort . . . and does it with a beauty of functional design that reflects the high reputation of the device.

Cooled or heated air blown through outmoded grilles or plaques, usually does not result in successful air-conditioning. Instead, such air-distribution results in erratic air currents and drafts which bring about discomfort — if not, indeed, unhealthful conditions.

The patented Anemostat (readily installed in any existing or contemplated air-conditioning system) is a scientifically designed air-diffuser. It thoroughly changes and evenly distributes conditioned air. It prevents drafts, stratifica-

tion, dead air pockets. It closely equalizes room temperature and relative humidity. It handles any duct air-velocity and permits a greater temperature differential between supply air and that of the room. Hence, it permits the use of smaller ducts and simplifies duct layouts — which lowers installation and operating costs.

In short, Anemostat fully meets the five air-conditioning tests which you must of necessity apply — Comfort, Health, Fine Appearance, Long Life, Trouble-Free Operation. Yes, Anemostat is a name you can proudly add to yours!

Include Anemostat air-diffusion in all of your future air-conditioning plans — you'll be proud of the results! Complete details gladly sent on request — and there's no obligation.

**"NO AIR-CONDITIONING SYSTEM IS
BETTER THAN ITS AIR DISTRIBUTION"**

ANEMOSTAT

REG. U. S. PAT. OFF.

ANEMOSTAT CORPORATION OF AMERICA
10 East 39th Street, New York 16, N. Y.

REPRESENTATIVES IN PRINCIPAL CITIES

AC-1116



15 OUT OF **16**
NEW MANHATTAN APARTMENT
BUILDINGS will have

HONEYWELL

PERSONALIZED HEATING CONTROL

IT'S pretty conclusive proof that a product has something important to offer when it gains such a degree of acceptance. And that's the record established by Honeywell Personalized Heating Control among the new apartment building construction projects now under way in Manhattan. Fifteen modern elevator-type structures to be P. H. C. equipped—15 out of 16!

Personalized Heating Controls give apartment dwellers the ultimate in heating comfort. With one or more Honeywell thermostats installed in every suite, each tenant is able to select his own temperature at all times. From an operating standpoint, P. H. C. systems are saving fuel at an average rate of 20%. That's a benefit property owners are quick to appreciate.

You can specify P. H. C. systems for existing buildings, too. By an ingenious method developed by Honeywell, installation is handled as simply as installing a telephone. Get the facts now about this newest system of heat control for apartment buildings—both large and small. Minneapolis-Honeywell Regulator Co., 2600 Fourth Ave. So., Minneapolis 8, Minnesota. Canadian Plant: Toronto 12, Ontario.

MINNEAPOLIS
Honeywell
CONTROL SYSTEMS

COORDINATING THE COORDINATORS

ONE of the functions of the architect, (assumed to be a function of any architect) is that of "coordinator" of the building project. How valid, how realistic is his assumption? Is "the general direction and supervision" of the project a function which is and should be delegated to and assumed by the architect in order to obtain the best possible result for all parties concerned? And if so, what is or should be done to insure professional competence in performing this function? What ability, training and experience are necessary for this role? Where and how does he get them — or did you?

In one sense the (or an) architect is the coordinator — for in his designs, his drawings and specifications, his services, are incorporated the desires and needs of the owner, the basis for the computation and judgment of the financiers, the complex systems and calculations of the engineers, the selection of the manufacturers' products, the precise instructions to contractors and trades, and the law-imposed requirements of society at large. But this is coordination in terms of design rather than execution.

In a more usual and widely accepted sense, "coordination" of a building project connotes responsibility in administration and executive control. This is the client's natural understanding of the term, and the one on which he frequently bases his evaluation of the architect. Coordination in this sense implies dealing with people rather than with things and ideas. It involves both persuasion and forcefulness, both tact and command, sound judgment based on technical knowledge, and the power of convincing expression. It involves efficiency in organization, thoroughness in detail and timing, as well as personal loyalties and integrity and sincerity.

While it is true that ability as coordinator in this sense seems to stem from inherent personal character and early-acquired characteristics, "doing what comes naturally," it is also true that such ability can be cultivated. It is heartening to learn that some of the architectural schools are paying more attention to this most important phase of training for full, well-rounded architectural competence. Others, however, omit it with the feeling that time is too short for anything but Design and its handmaiden Construction. They know from long experience that the major interest of the majority of students is Design, and that Design is the essence of Architecture. But to make creative design effective, the architect must demonstrate competence as coordinator in *both* connotations of the word. The sooner this is realized by the embryo architect, the better, and the early years of architectural school are none too soon. Too rarely, perhaps, executive and administrative ability is coupled with creative design ability in the same person.

It would seem to be the function of the schools to train both talents, for architecture as practiced today demands both, either as teams or firms, or more rarely in the one-man office. The effective practice of architecture demands the integration, in one responsible organization, of the three prime functions — Design, Engineering and Administration. Such coordination in the architectural office itself is essential if the architect is to be in truth "coordinator" of the work.

Kenneth K. Stowell

EDITOR



DRAMATIC PRESENTATION OF SOUND

Display Rooms for RCA Victor Division, Radio Corporation of America, Camden, N. J.

Carroll, Grisdale and Van Alen, Architects

In designing a showroom for an internationally famous producer of sound equipment, the architects have had a triple assignment to meet. Technically, their installation must be exemplary. Good merchandising must be achieved for the manufacturer and sound methods must be demonstrated in turn to visiting distributors of his products. And, finally, to make an adequate impression, in a rapidly developing field which daily witnesses fresh miracles, the display must be dramatic.

In drama, in particular, the architects have succeeded admirably. In a room so small as the theater (frontispiece), which is less than 24 feet square, there is rarely achieved so vigorous a unity of impression. There is not one bit of that timidity in handling sound control, in a small area, which has characterized the work of those who are unsure. By its vigor the RCA company proclaims its confidence in its own technical expedients. The room may serve as an example for those needing small theaters in countless other contexts.

(It may well be added, parenthetically, that the photographer has achieved a faithful equivalent of this room, reproducing the excitement which the design generates, but that there is also in the room that friendliness of texture and that repose which are necessary for long-term comfort and acceptance.)

The theater in its corner (see plan, overleaf) is the dramatic climax of a careful plan sequence. The entrance serves not only the display rooms but the multi-story building in which these are found. Since a good many visitors are expected in the building, an information desk is prominently and conveniently located in this lobby.

The reception lounge, off to the right, is properly arranged out of the way of traffic but open to the entrance making it easy for new arrivals to see and be seen.

The large main room is occupied by equipment produced by the manufacturer. It is under control of an executive who occupies an alcove directly off the entrance to it.

Diagonally across from the executive's alcove is an exemplary installation of a central sound control system, connected to the theater and to a small "announce" room as well as to the room of the program director.

This installation is glass-enclosed and, by special illumination, is high-lighted so as to become the main



Ben Schnall Photos.

Glass and metal entrance to the main display room makes it visible to all visitors in the building, not only to customers.

center of attention. The photographs show how flexible is the vocabulary of illumination, using not only ceiling-recessed down lights, indirect incandescent lighting, and fluorescent lights in coves, but also — and most striking — the newer expedient of the scintillating "egg-crate."

The mutual relationship between the control room, the "announce" room, the theater and the director's office is very closely considered, even though to the visitor the impression given is one of casual ease. Of great importance to the company is the result seen in the very last picture of our series (bottom of page 94) that there is a clear view from the control room into both the "announce" room and the theater, but there is *no* direct access between any of the three. All traffic has to go through the vestibule.

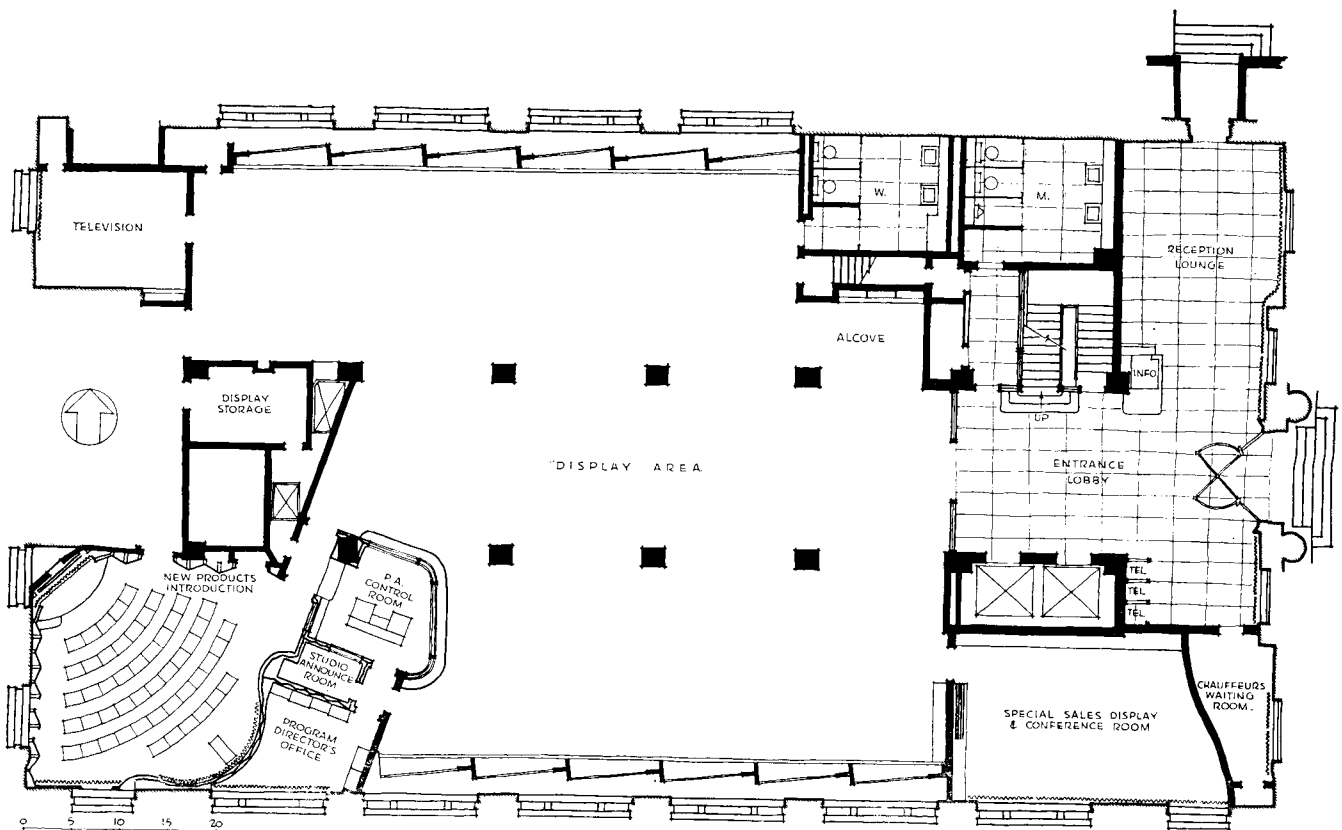
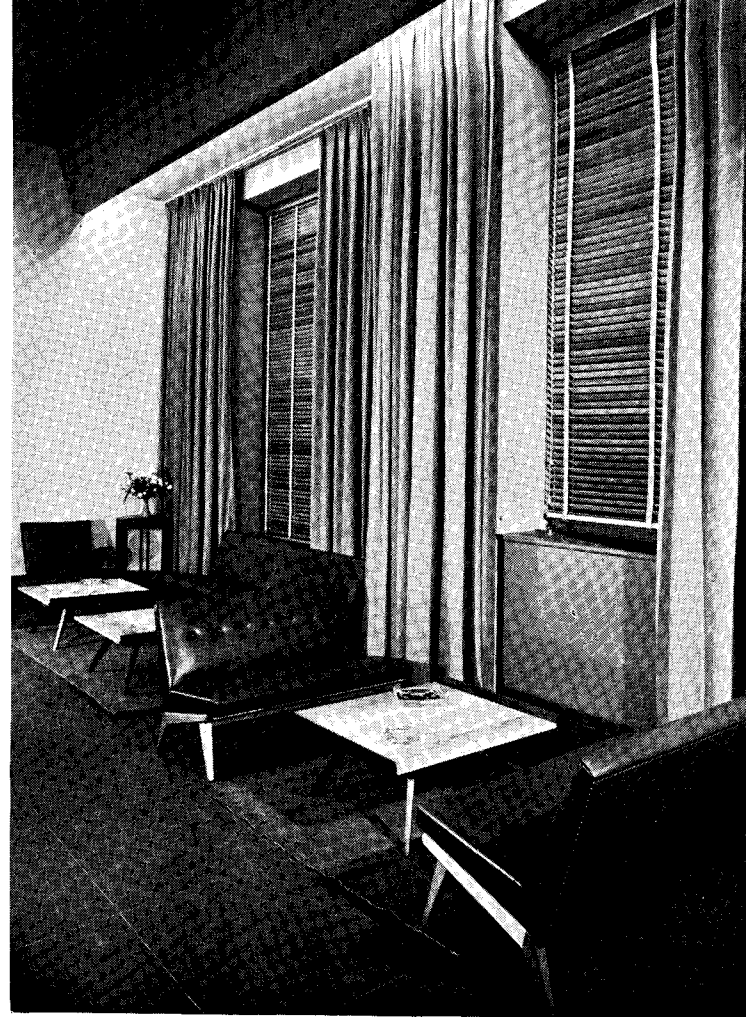
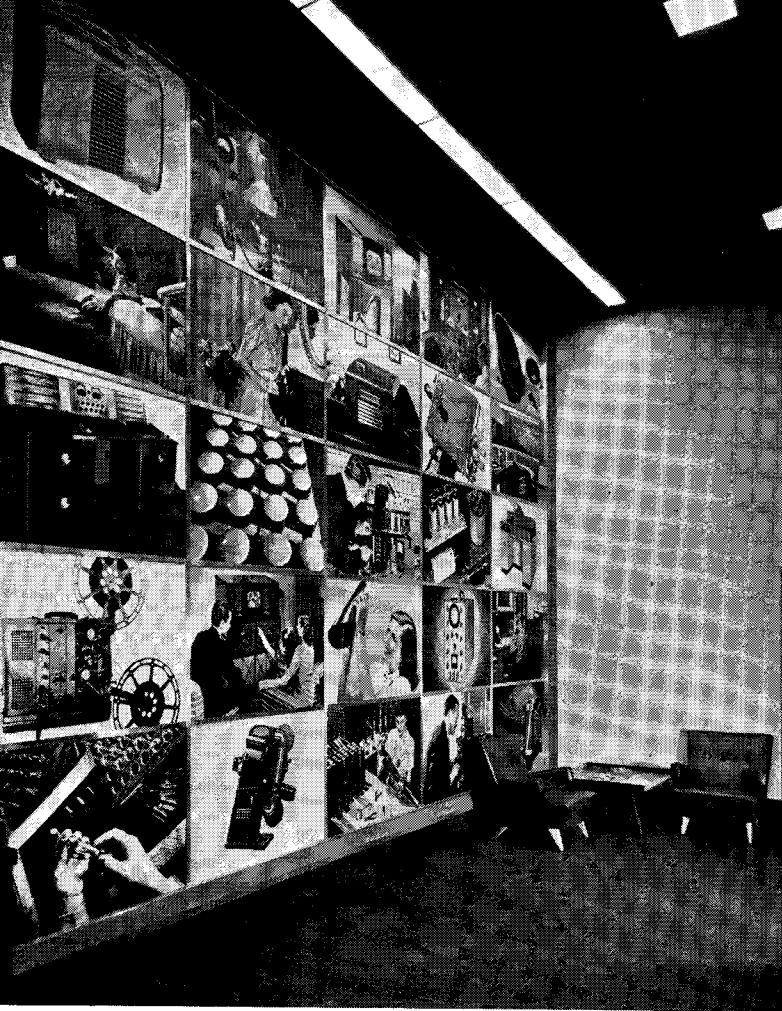

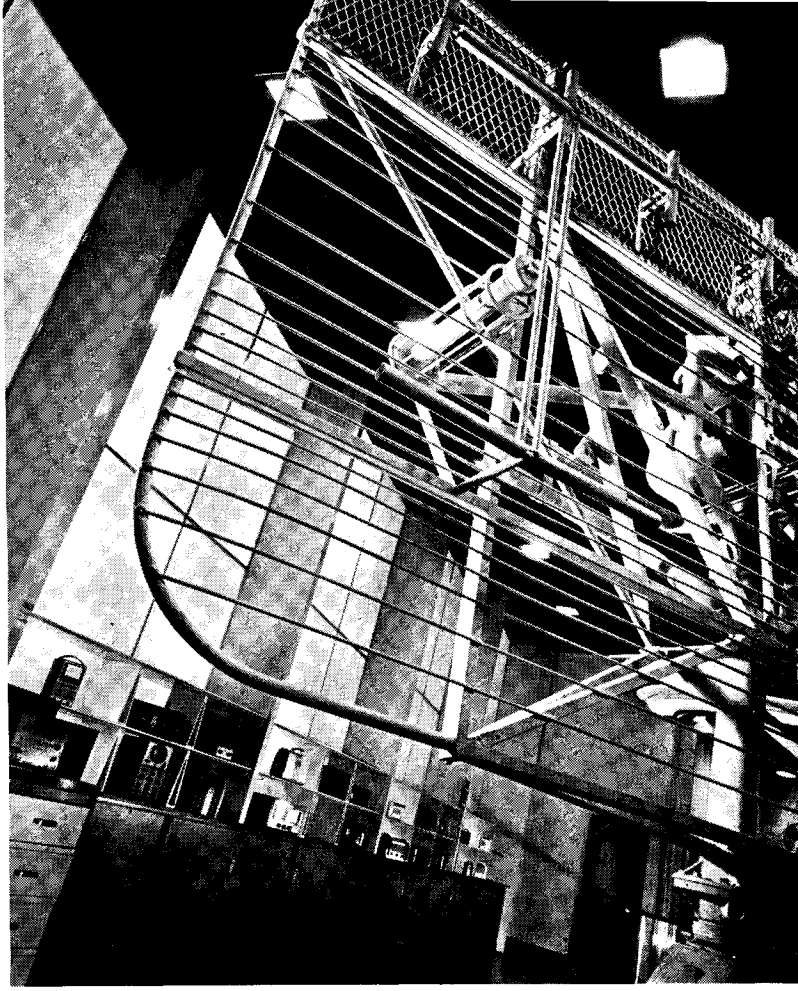

OPPOSITE PAGE, top, two views in reception room. Photomontage lit by continuous flush down lights. Ceiling, deep green acoustic tile, carries through into main display room. Walls and curtains gray, furniture natural birch, floor black.

THIS PAGE: Top left, entrance to conference room; top right, view through a piece of radar equipment into the main display room. General illumination, recessed flush incandescent down lights; cold-cathode tubes above metal egg-crate louvers hung from air conditioning ducts; display light from recessed spots. Glass is sand-blasted plate. General colors same as entrance foyer, accents from materials on display, mainly free-standing on floor

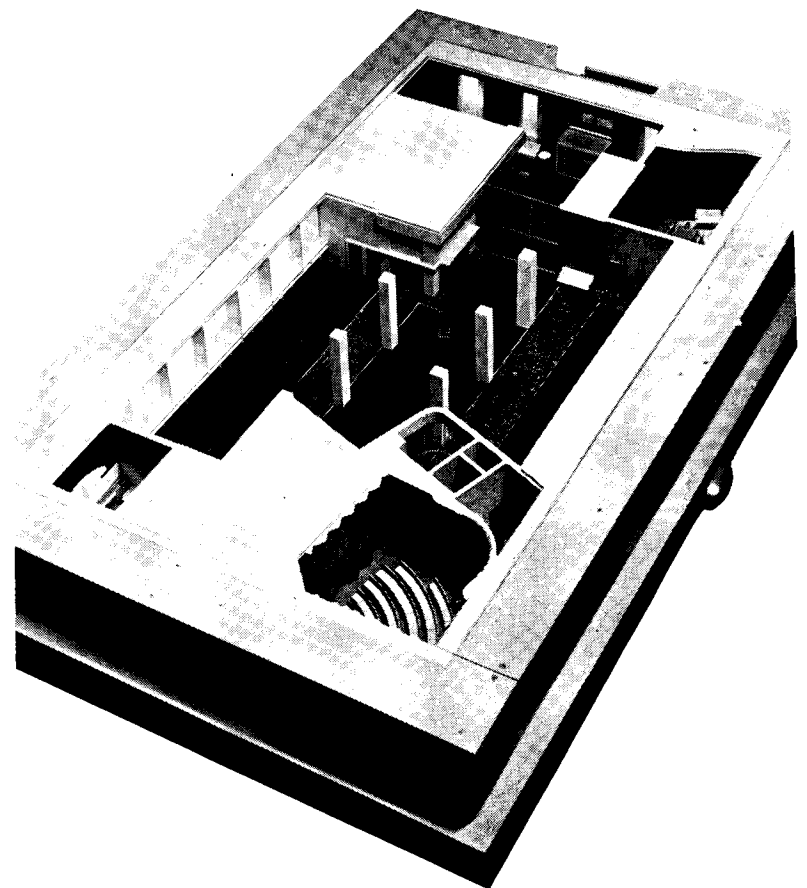

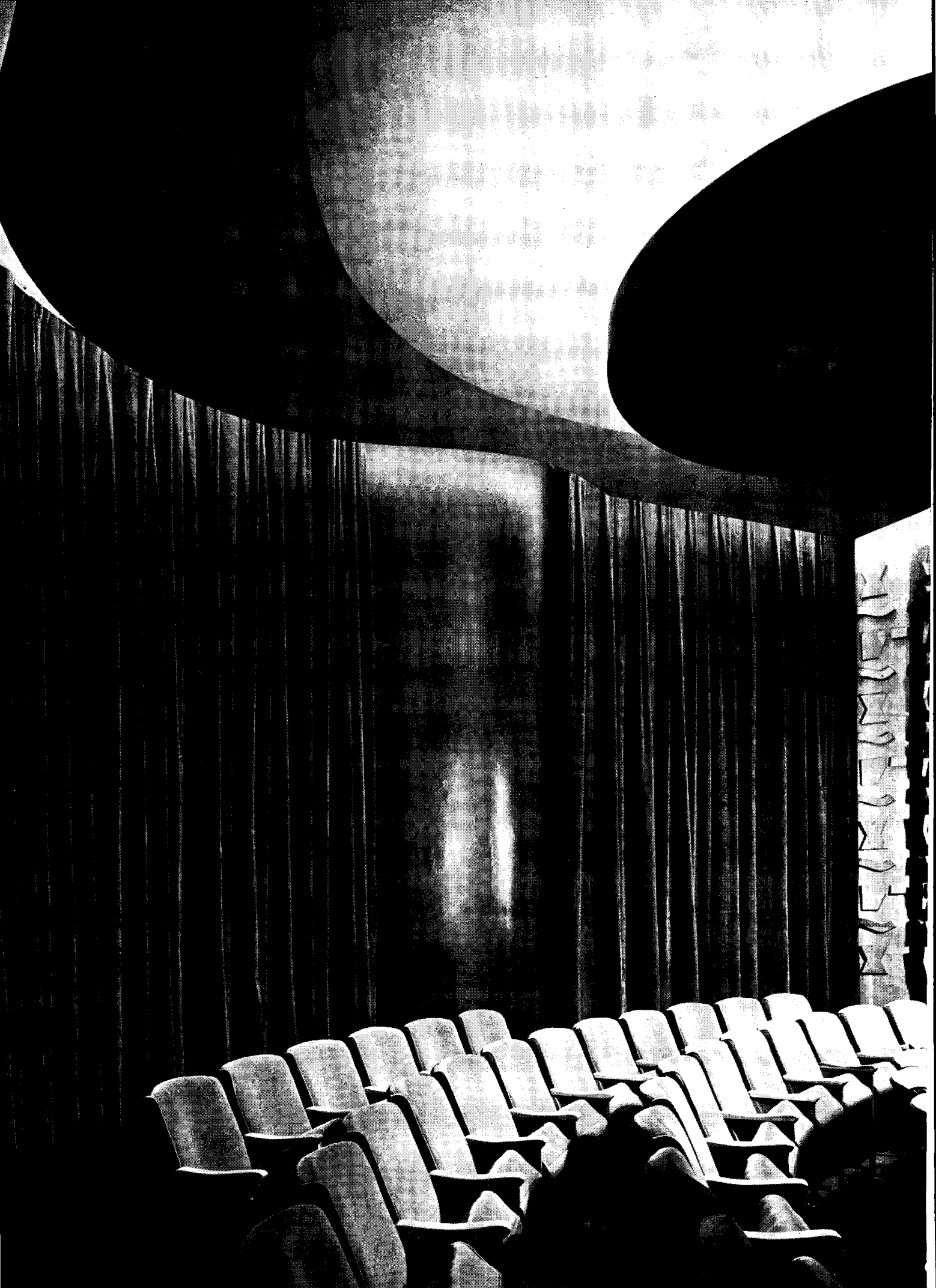

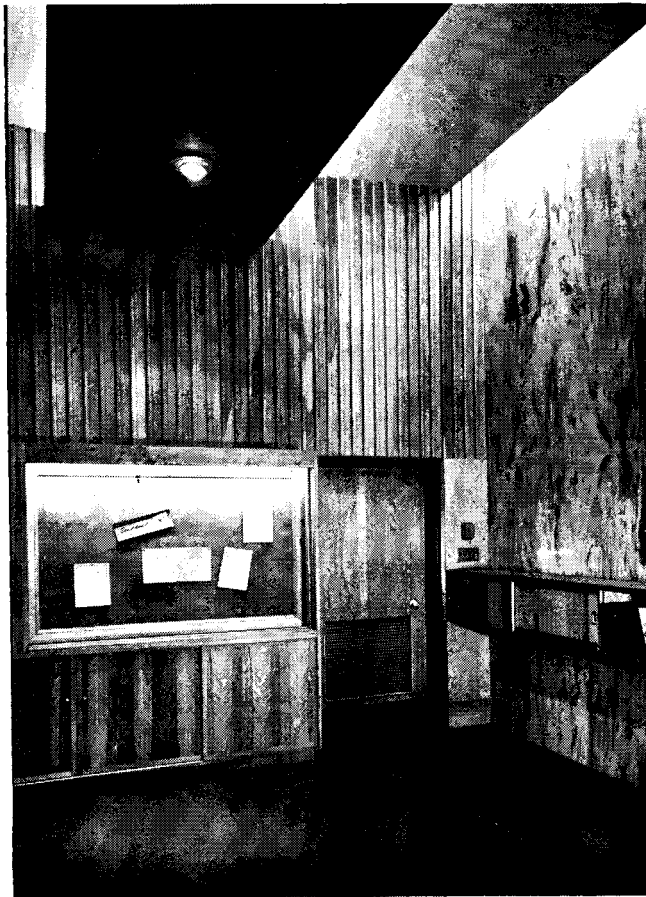
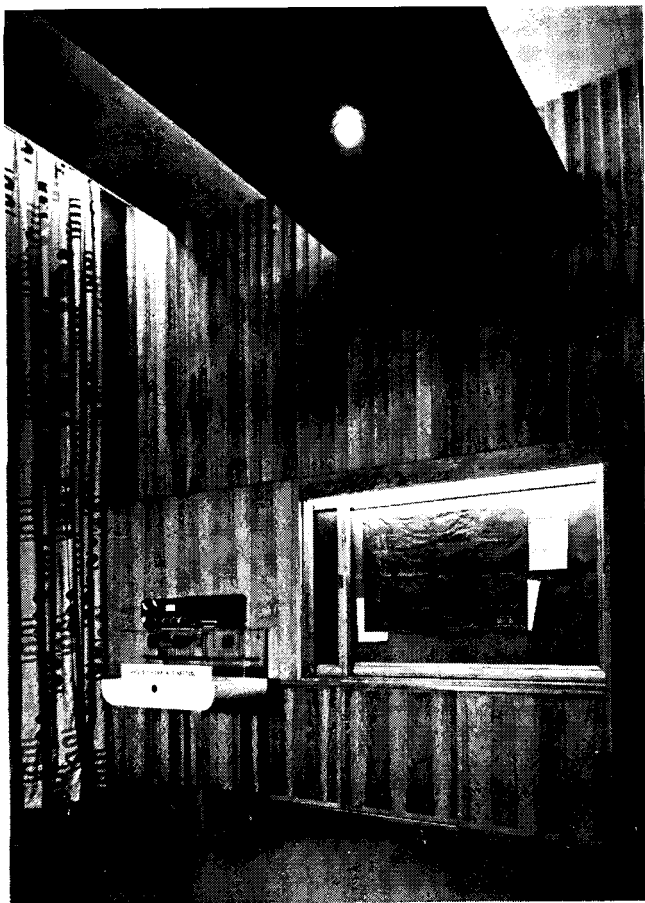

THEATER (or "New Products Introduction Room"), opposite page, has a rear wall with concave surfaces covered by traversing curtains, convex surfaces uncovered. The ceiling is of plaster and there is a sound-absorbent panel above the stage. Floor carpet and walls are deep green, ceiling green and deep grayish pink; seats are covered by light green upholstery. (Curtains behind stage are brilliant red.) The combination of hard plaster rear wall and soft curtain gives control over brilliance or softness of sound in various registers

THIS PAGE, top Two views in conference room. West wall is in birch paneling, north wall pink marble, east wall deep blue-gray painted plaster. south wall curtained. Light is from cold cathode tubes in ceiling troughs and incandescent down light in the central hanging soffit

RIGHT. Sales executive's off-entrance alcove

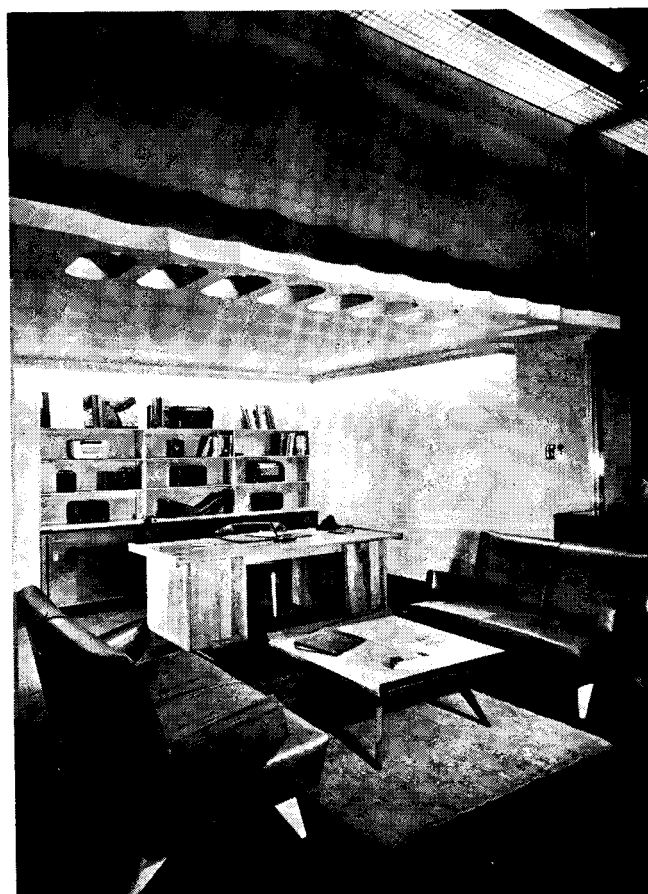

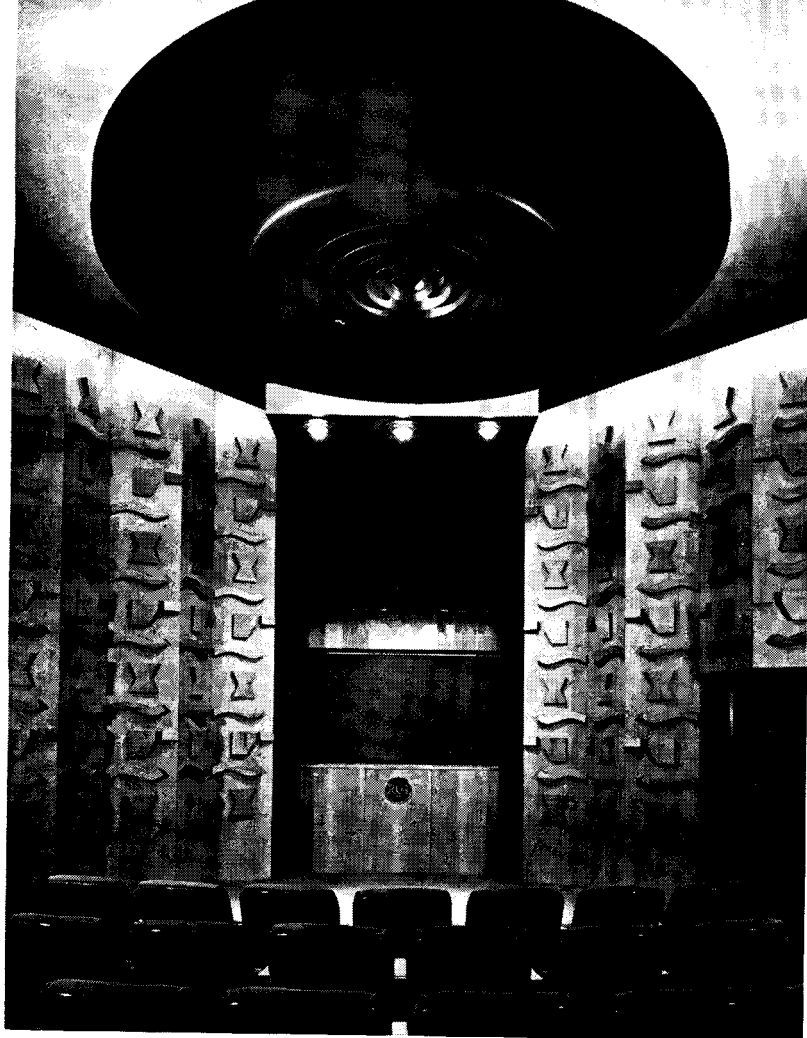

LEFT: Front of theater has a stage that more often presents equipment rather than people. Sound-absorbent dropped panel above stage carries spotlights; general indirect light by incandescent bulbs on hung soffit is controlled by electronic dimmer. RCA emblem conceals 10-in. loudspeaker which connects with sound-film projector at rear for theatric programs

RIGHT: Natural birch paneling arranged in zig-zag patterns breaks up sound reflections, aided by the large-scale applied figures, also in the same birch finish.

Photograph gives a good impression of the light drifting down this textured surface from the hung soffit; still further light comes from above the dramatic central ceiling anemostat

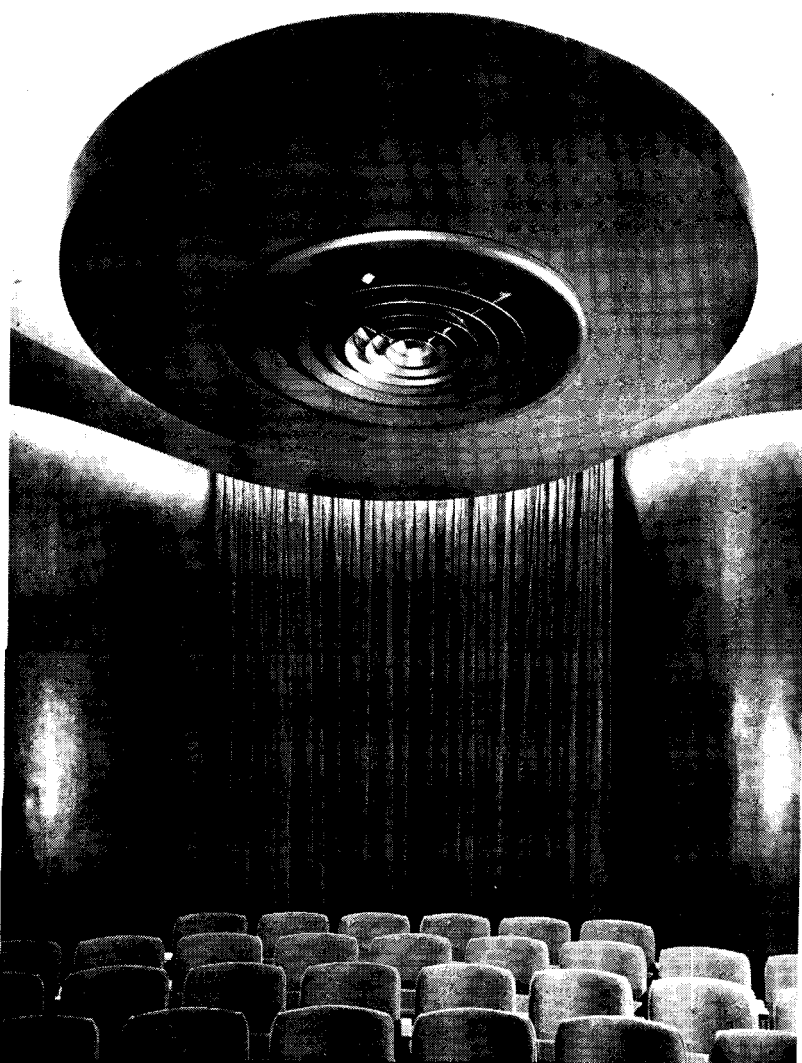

LEFT: Rear of theater stands in effective contrast to the stage. The plush curtain provides acoustical correction for the concave wall



Windows of this sound control room are quarter-inch plate mounted in aluminum frame and set in mastic felt and rubber.

The console thus enthroned controls distribution of sound and inter-plant broadcasting to 92 areas in 19 buildings, some of them several miles from the plant. Equipment racks in same control room are through-wall mounted to provide easy access from front and rear

Of high importance in the planning of sound control facilities is this through-vision (below, right) from control room into both theater and "announce" room (sound-proof glass) but physical access is only through an intermediate vestibule



DESIGN FOR DEMONSTRATING DESIGN

Offices and Laboratory for Walter Dorwin Teague, New York City

Ben Schnall Photos

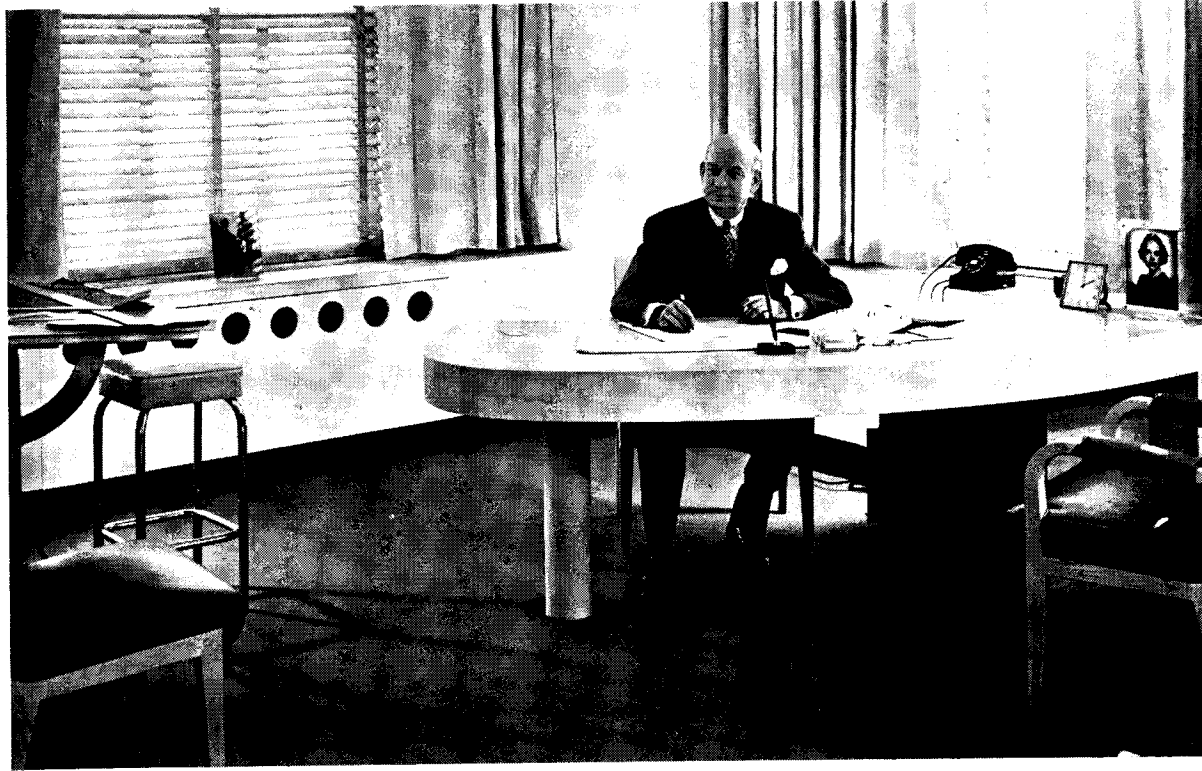

SINCE design is never static, but must follow the ever-changing dictates of function, it seems perfectly logical to expect that a professional designer would find his own offices calling for his services, as expansion and new activities affect their functioning.

The photographs show a recent rearrangement of the offices of Walter Dorwin Teague. The alterations principally provide better quarters for Mr. Teague and his partner, Robert J. Harper, director of design, on the 29th floor at 444 Madison Ave., New York. The firm also occupies the 41st floor, and half of the 23rd in the same building, with a shop and laboratory floor at another location. Such separations are typical of spaces in crowded New York offices, and not infrequently introduce complications in functional arrangement. Here expansion of the executive suite necessitated the moving of the accounting department and much of the stenographic and filing services to other floors.

Mr. Teague's office is designed for multiple use. A large curved desk, with comfortable armchairs facing it on both sides serves for the usual discussions with members of the staff and with individual visitors. The drawing board is conveniently located adjacent to the

desk. A conference table seating eight is provided for discussions with clients. In one corner a built-in couch, lounge chair and low coffee table make a comfortable setting for less formal occasions.

The ceiling of this room is hung below the beams and faced with smooth acoustic material. Two fluorescent fixtures running the long way of the room provide a high level of illumination, and there are additional concealed lights over the cork wall and the couch. The floor is carpeted over a heavy pad, and the combination of carpet with acoustical ceiling and draperies makes for maximum acoustical comfort.

The couch and chairs are upholstered in vermilion and off-white, rawhide Fabrikoid. The coffee table has a double top, the upper being of heavy plate glass, with shells used decoratively under the glass.

The desk, conference table and coffee table were built in the woodworking division of the Walter Dorwin Teague Development Laboratory, 245 W. 55th St. The chairs and couch were constructed from Teague designs by Artek-Pascoe.

Mr. Teague's drawing board was especially designed and constructed with a framework of aluminum.

New office and conference room of Walter Dorwin Teague, a former founder and president of the Society of Industrial Designers. His new office is part of a major alteration to the headquarters office

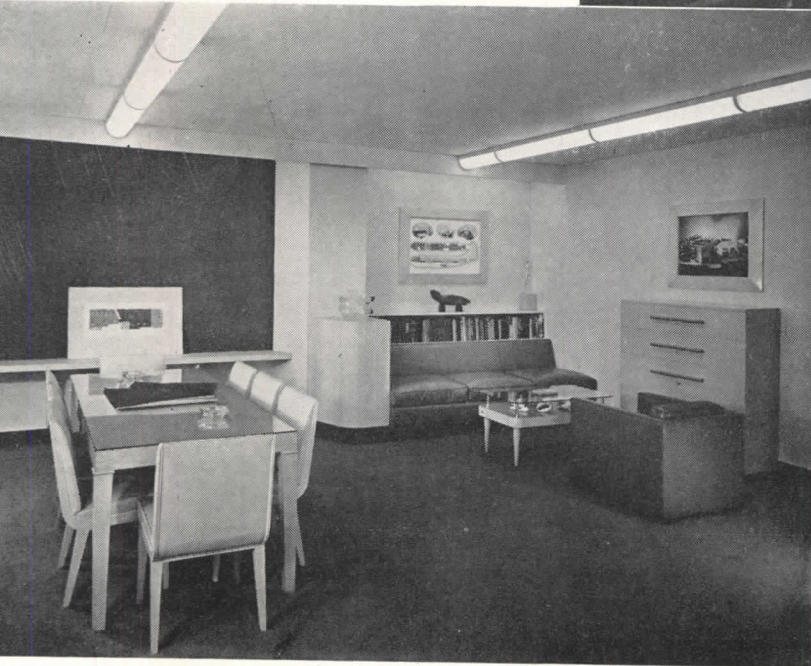
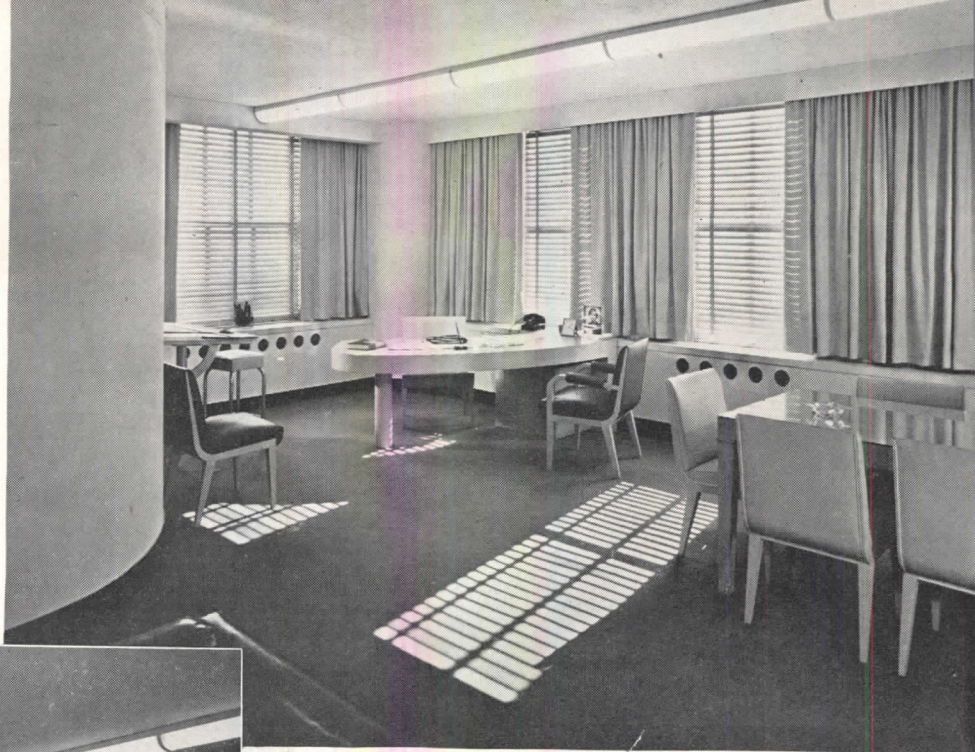

All furniture in Mr. Teague's office is of bleached rift oak except a cabinet against the wall, which is lacquered gray with gold fittings. The bleached oak is used throughout the floor, with vermillion and rawhide upholstery. Floor of lobby and offices black linoleum

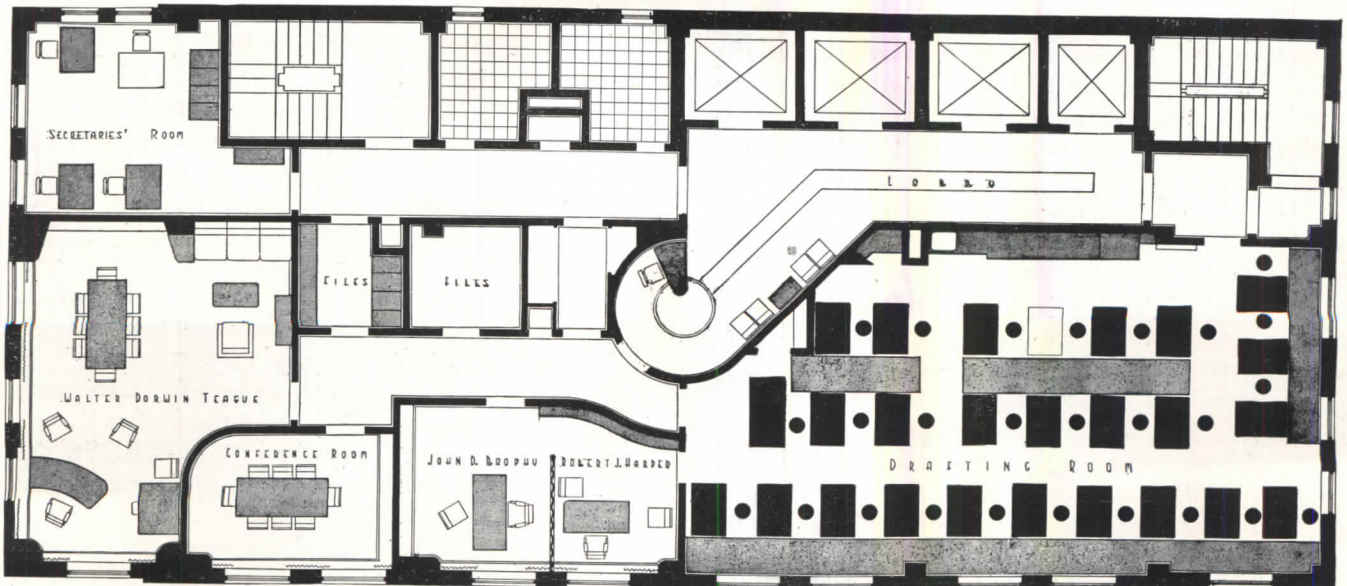

TWENTY-NINTH FLOOR



A free-flowing wall, in Mr. Harper's office, with free-flowing bookshelves, is photogenic and intriguing, but is more functional than whimsical. The rounded reception lobby put a twist into the interior corridor leading to the drafting room, the curve necessarily being taken out of the office space (see plan on opposite page). Mr. Harper, director of design, has his own door directly to the drafting room (background in photo). Below: the drafting overflows onto the 41st floor. The accounting department was moved here to permit alteration on 29

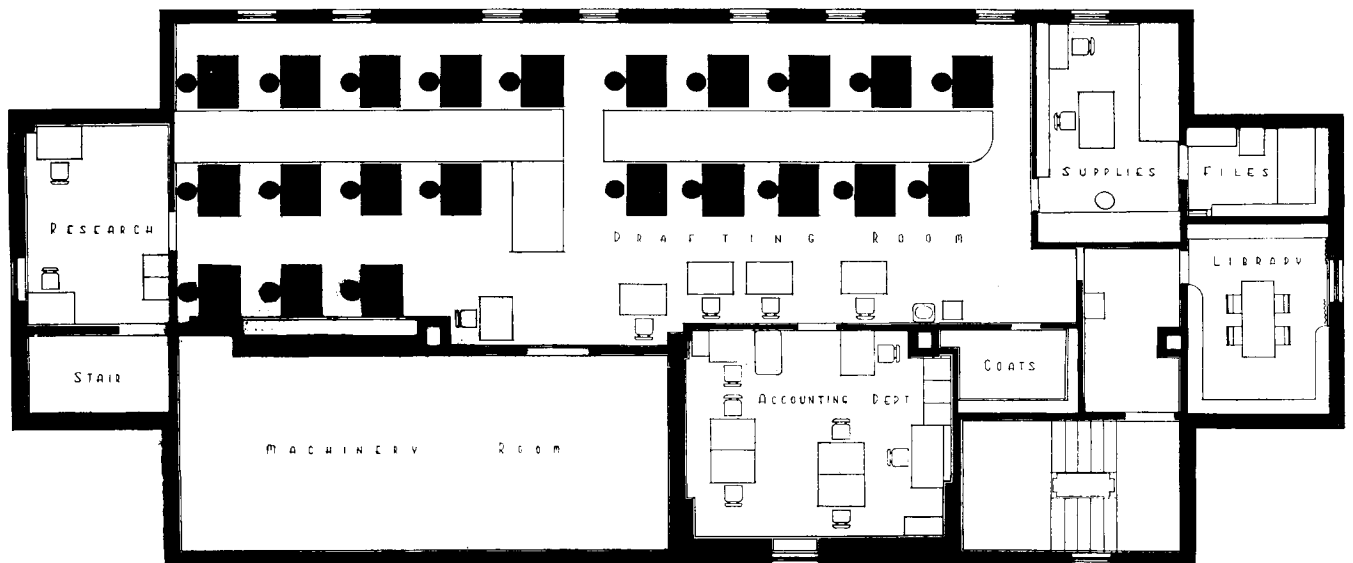

FORTY - FIRST FLOOR



Above and below: Ben Schnall Photos

Above: a discussion of product design in the conference room on the 29th floor. Right: two views of the Teague Development Laboratories; these are in a separate building, at 245 W. 55th St. Below: view of the drafting room on the 29th floor; there is another on the 41st

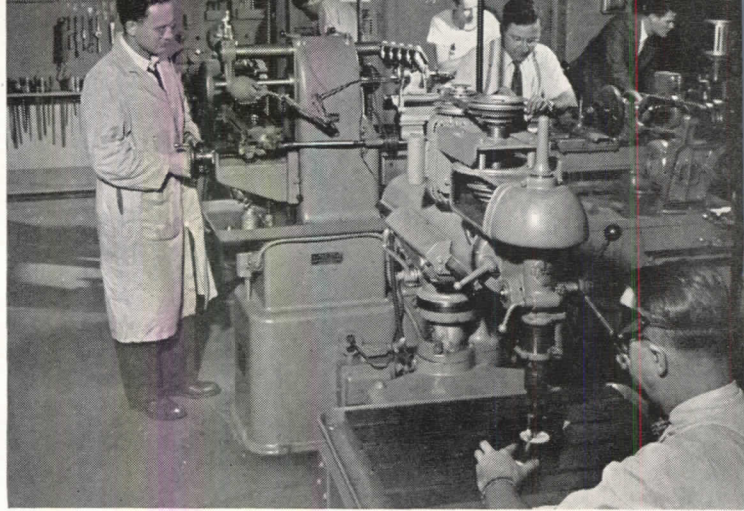

Robert Elliot Photo

Below and right: Richard Garrison Photos

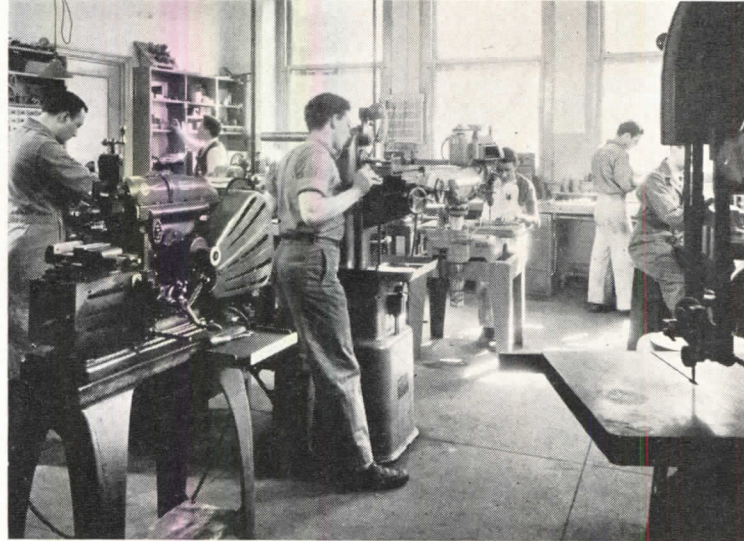

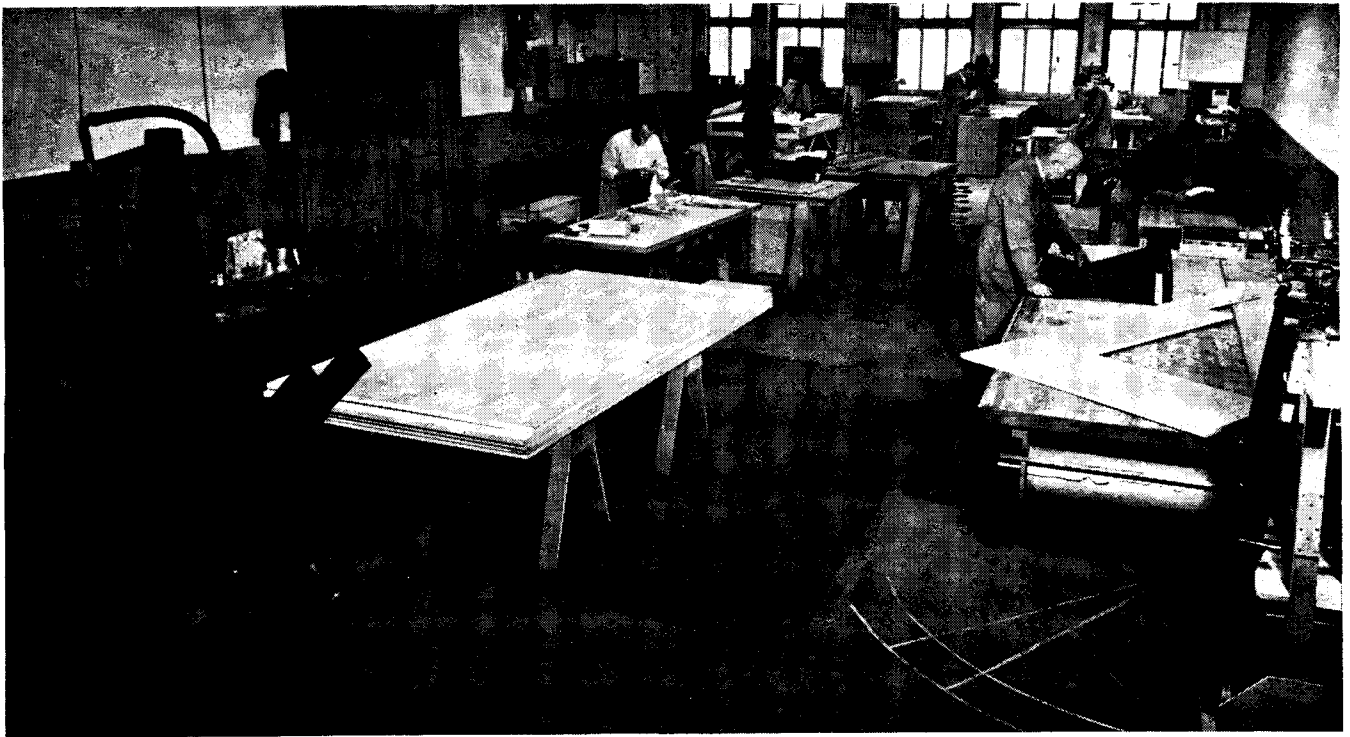

The model shop of the Teague Development Laboratory is equipped with all necessary woodworking machinery, including a spray finishing booth. The laboratory occupies 5400 sq. ft. at 245 W. 55th St., New York, and contains also a machine shop, model shop, electronics laboratory, drafting and conference rooms. Here the imaginative theories of the design staff get their first test in visual and working models. Here also tests can be made of the effect of function on design and vice versa. The laboratory is staffed by a combination of test engineers and development engineers and skilled mechanics, to aid, and also challenge, the design staff

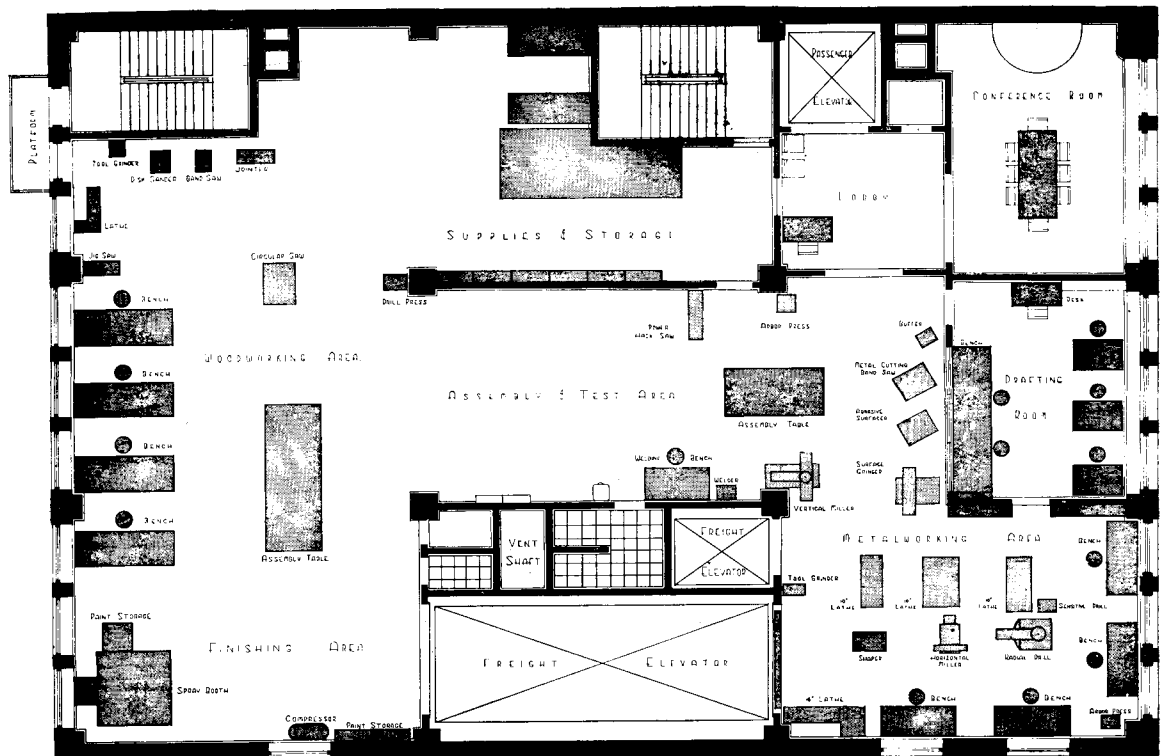

PLAN OF DEVELOPMENT LABORATORY
FOURTH-FLOOR PLAN OF 245 WEST 55 STREET

DESIGN FOR DEMONSTRATING PLASTICS

Quarters for Industrial Design Staff, General Electric Plastics Division

WHEN William B. Petzold designed quarters for himself and the design staff for plastics, he naturally leaned toward glamorizing both the office and the product, while making use of a trapezoidal remainder of space. The color scheme is a manipulation of blue-gray, walnut, gray and a redwood tone on a rough-textured wall, with transparent plastic accessories. Furniture in-

cludes a sofa of foam rubber construction, covered with black Vinylite. Lucite appears in the door pulls, fashioned in the occupant's initials, in the conical clock knobs, switch plates and so on. Plexiglas makes the door to the outer secretarial office. The desk unit has work surfaces of G-E laminated plastic; the tubular supports of the desk are of the same material.

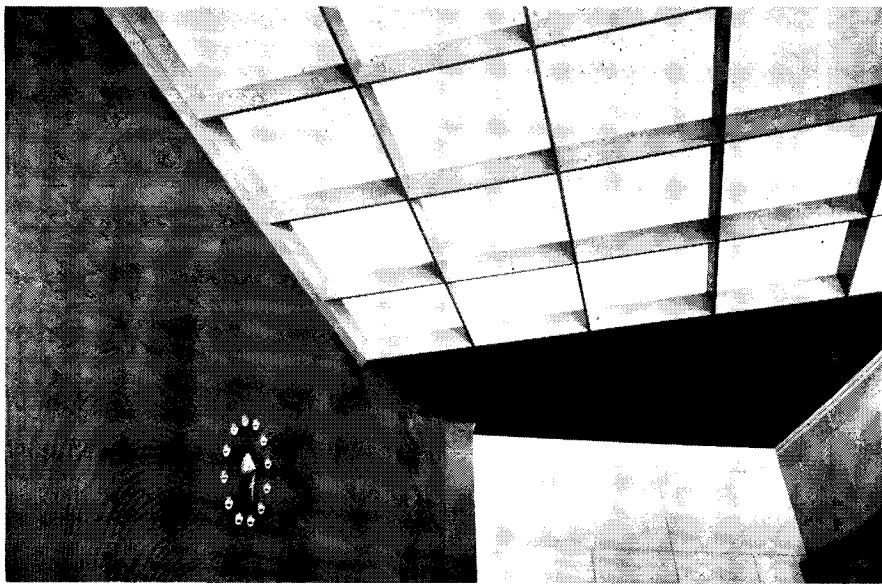

A novel use of the egg-crate with fluorescent lighting -- a covered egg-crate dropped 2 ft. below the ceiling. Each 24-in. module is covered with a panel of translucent laminated plastic, giving uniform distribution of light without glare



The plastics demonstration continues in the space occupied by the design staff. The drafting-desk units have the plastic top, and translucent plastics form the fixtures for fluorescent lighting, also the egg-crates incorporated in fixtures

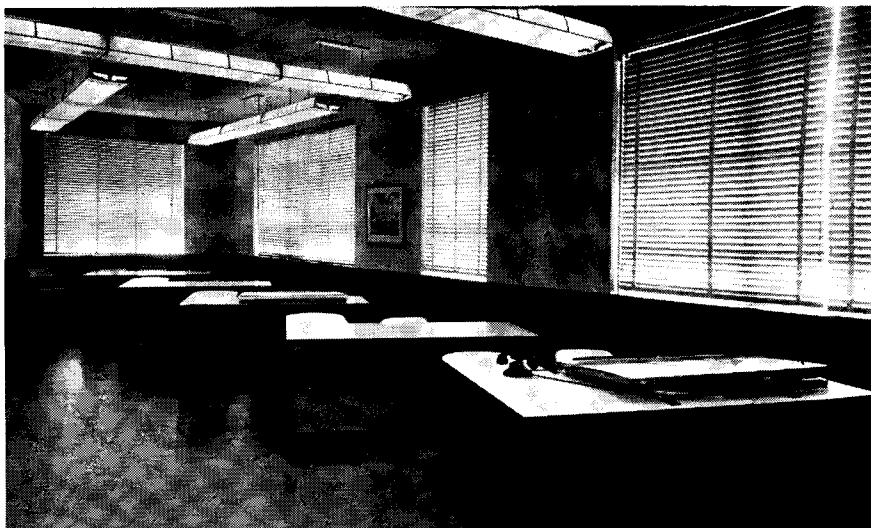

Desk is part of a single unit incorporating built-in storage cabinets and drawers. Drawer pulls, fabricated of Lucite, are mounted on adjoining ends of drawers, to present a decorative unbroken line from top to bottom of the drawer assembly



The secretary's desk takes its form, also its materials, from the designs for the boss's. The fluorescent fixture above is a dramatic touch in an office devoted to plastics design. Partition and wide door (seen in open position) are of Plexiglas

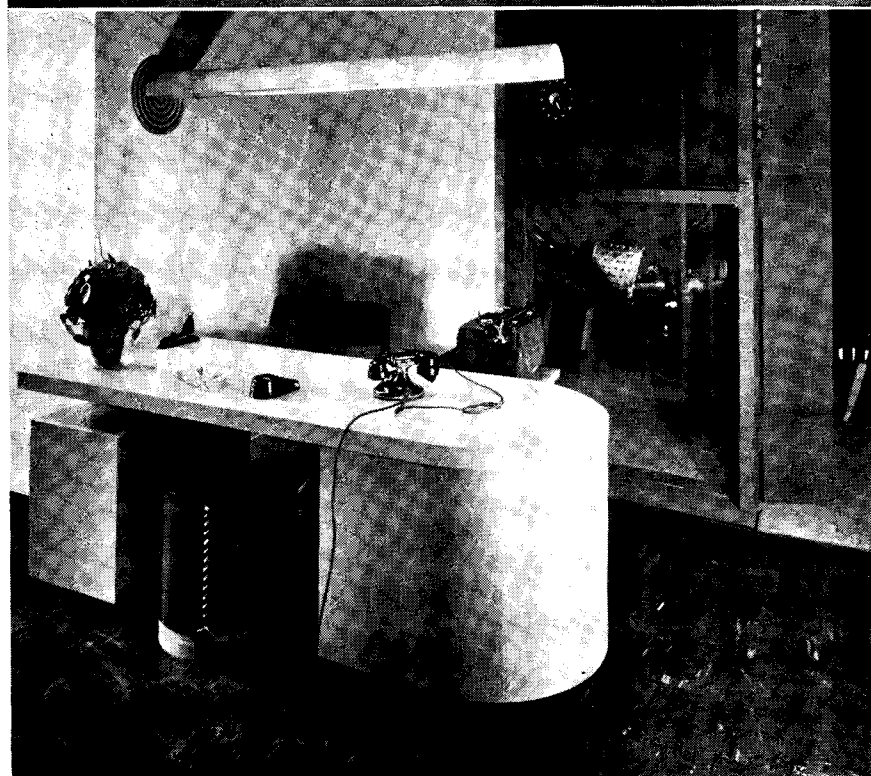



FRONT OF GOLD WITH DUAL MEANING

EDDY HARTH'S, BEVERLY HILLS, CALIF.

Paul Laszlo, Designer

GOLD-FILAMENT glass in these windows, says the designer, serves a double purpose, giving a soft aureate hue to the merchandise and, further, a measure of protection against too much sunlight. Other materials in the façade are travertine, bronze, and black structural glass. Also, three different types of neon light are used on the front for name-display attraction from various angles.

Inside, display cases are arranged to be visible from the street as integral parts of the whole, and to give, at the same time, an impression of distinct "sales units." Note also, in the plan, how the arrangement gives each unit its own dressing rooms. Mirrors are hinged to cases for adjustment by customers. Above the 8-ft. open screen subdividing the "full-dress" unit at back are corrugated glass panels, behind which is the mezzanine work and alteration room.



Julius Schulman Photos

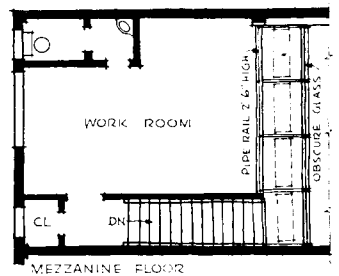
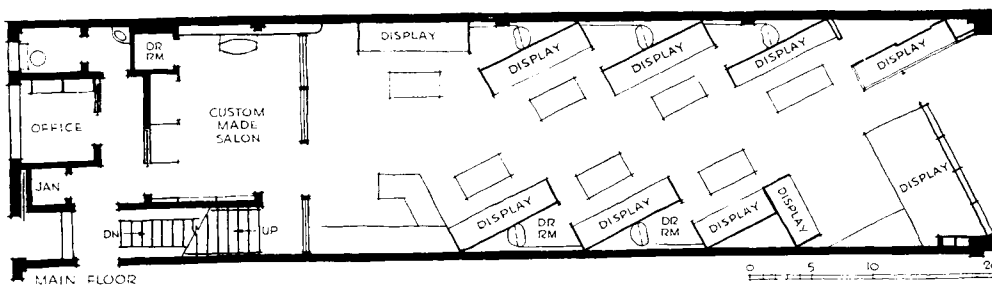
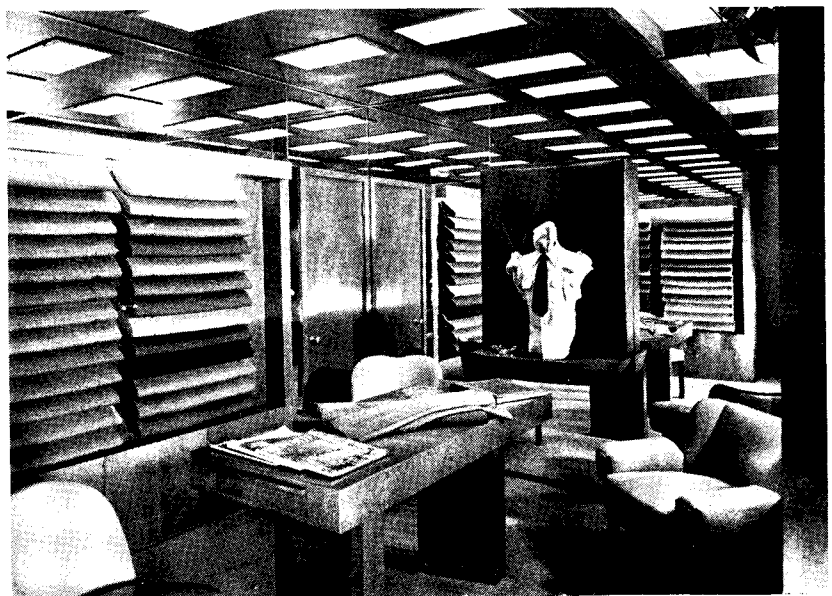
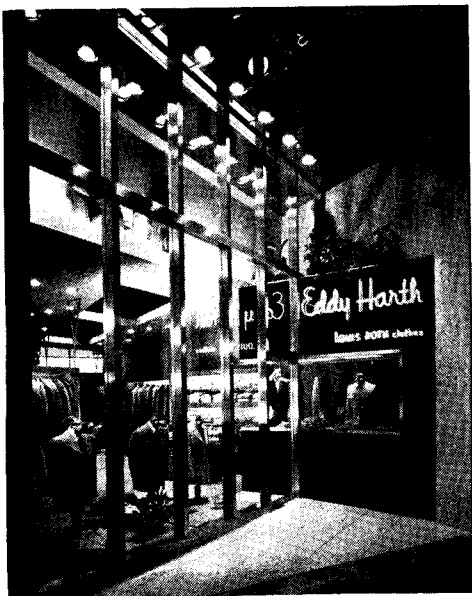

Door of corridor entrance to yarn showroom is also of oak. To right may be seen one end of a long display window, bordered in corrugated plywood. This continues the product story related in a preceding window by carpet receptionist's desk (see p. 104). Door knob and name letters are bronze. Large window to left discloses yarn reception area display

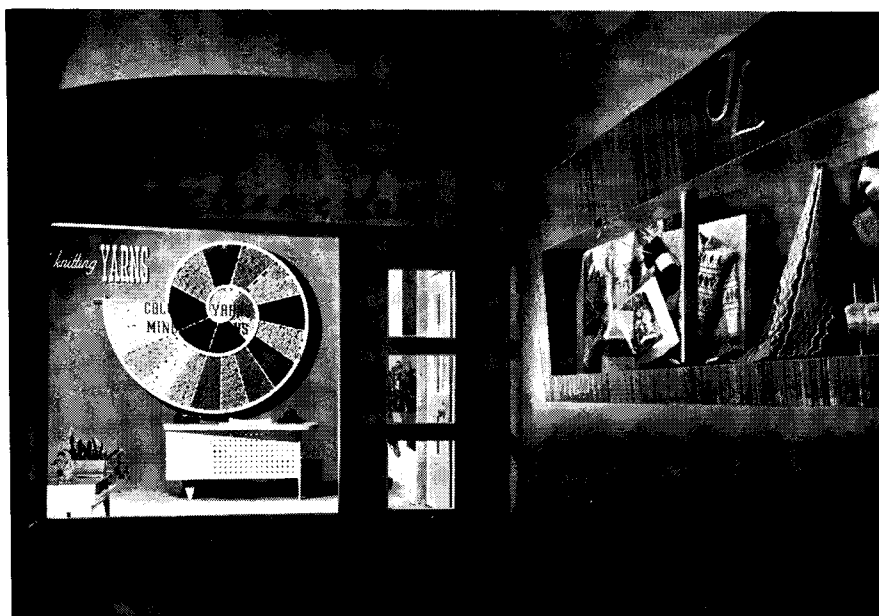

Left: yarn and carpet showrooms are interconnected by oak doors. Large dividing glass to right, supplemented with terracotta colored flower boxes and green plants, contributes clear demarcation and at the same time, an open invitational effect between the two main divisions. Pinwheel display contains balls of yarn in spectrum colors; wall is deep brick red

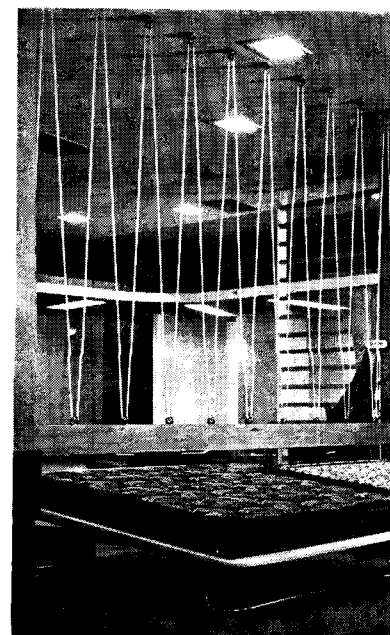



Directly above: general view of carpet showroom from point in outside corridor. Foreground area is devoted to Axminster carpets; Velvets and Wiltons are beyond partitions of white cording. Above (top): close-up of Velvet section shows special textured wall covering by Katzenbach and Warren; bar partition sets off "roomette" display. Left panel at rear is of deep-green muslin

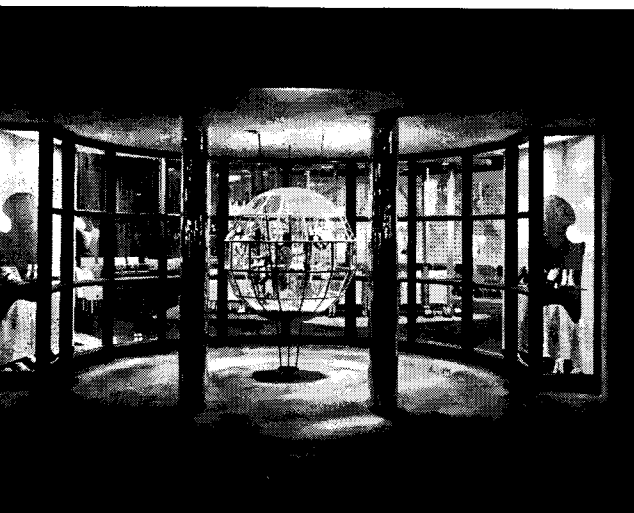

ANSONIA SHOES

Morris Lapidus

Architect

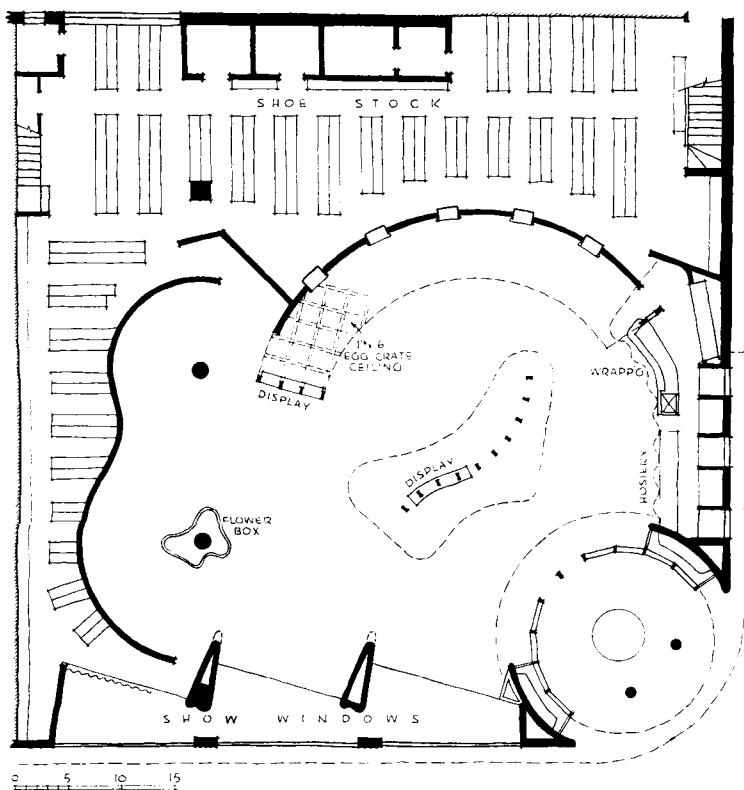

THE architect personally likes this job "because it was possible to become rather playful, to carry out the feelings of fun and frolic with which most people come to Miami."

Exterior show windows were sealed down "for intimate display," and to curtail spoliative effects of flooding sunlight. Spherical entrance display case is metal, plastic and glass. Color scheme of exterior walls is gray, yellow and deep blue.

Squat buttresses discernible to left in photo directly above are divisions between show windows, which open also into the store interior. They have no backgrounds for shoe display except "exotic foliage" set along the inside window ledges, giving in addition "a touch of the outdoors to the interior." Irregular piercings in the buttress walls are also used for spot shoe display. Note in the plan the substantial allowance given to stock, with convenient access from all selling points.



Moser & Son Photos

IN A FLORIDA SETTING

Above, left: wall of oak batten flooring forms selling background, conceals the stock behind. Wall-papered portion of screen wall is varicolored pastels; display niches contain bright Parakeets. Directly above: wrapper and floor cases are quilted in lime-yellow leather; drawers behind wrapper are for shoe ornaments. Below: island selling unit doubles as a display feature. Lime-yellow canvas forms a "nautical" background for chairs. Furniture throughout is chartreuse, forest green, lime yellow. Carpet for defining selling areas is rose; elsewhere, forest green

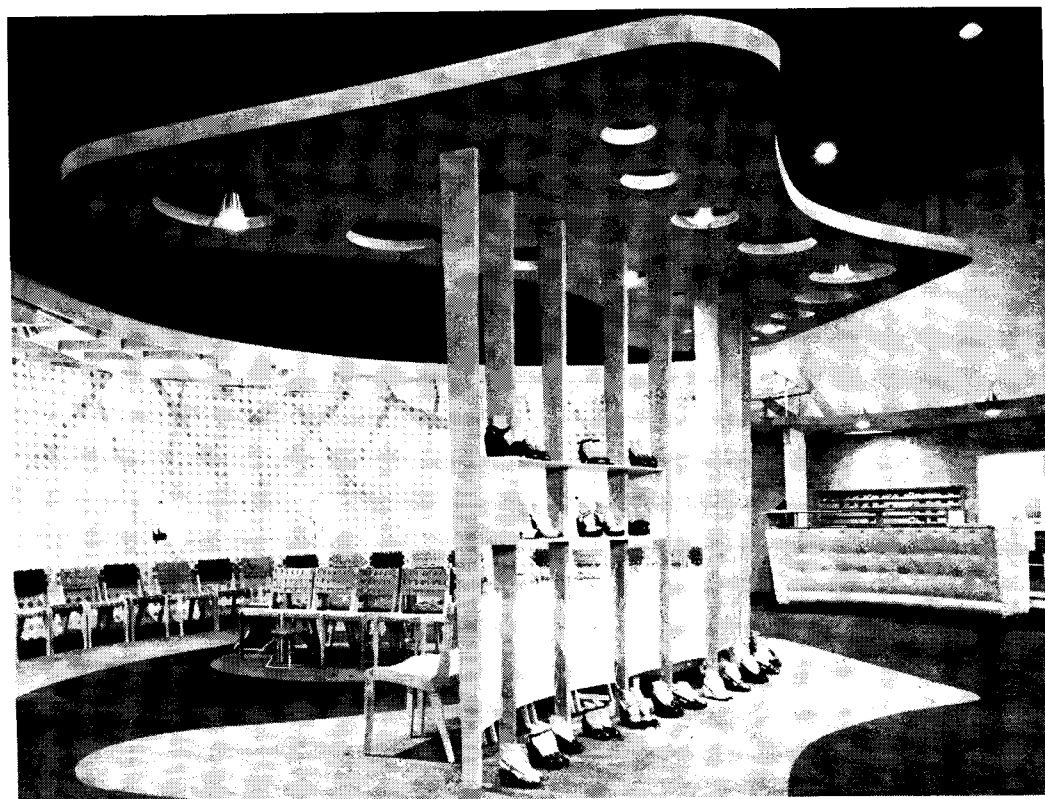



Exterior is of black structural glass, white window frames, stainless steel canopy; awnings are blue and white. Holes over entrance and window bays are 4-ft. in diameter, admit daylight; angle of display windows helps prevent veiling glare



Ben Schnell Photos

CARPET SHOWPLACE FOR BUGGY TRADE

CARPET MART, HEMPSTEAD, N. Y.

Herman H. Siegel, Architect; Ernest D. Rapp, Designer

SOLUTION of an unusual site problem, for this retail carpet and linoleum showroom, created a by-product of substantial advantage and inducement to suburban shoppers furnishing motive power to baby carriages. The site slopes abruptly; in addition, there was an existing foundation wall, 4 ft. high, across the present ramp's upper point of termination (see plan, over page). Rather than reduce it at pointless extra cost, the designers capitalized this condition by extending the building front

and introducing the ramp to selling levels. The buggies roll up effortlessly, providing huge diversion. In addition, the effect is that of a store front within a front: customers are afforded a mounting view of street window displays from the inside, and of other merchandise through the wire glass screens along the store side of the ramp. Thomas Smith Kelly was lighting engineer; Dominic Milone and Jack Stone were the general contractors.

Egg crate ceiling is deep blue. Wood fins are red and blue. Major areas elsewhere are painted yellow and gray. Floors of ramp and window areas are linoleum

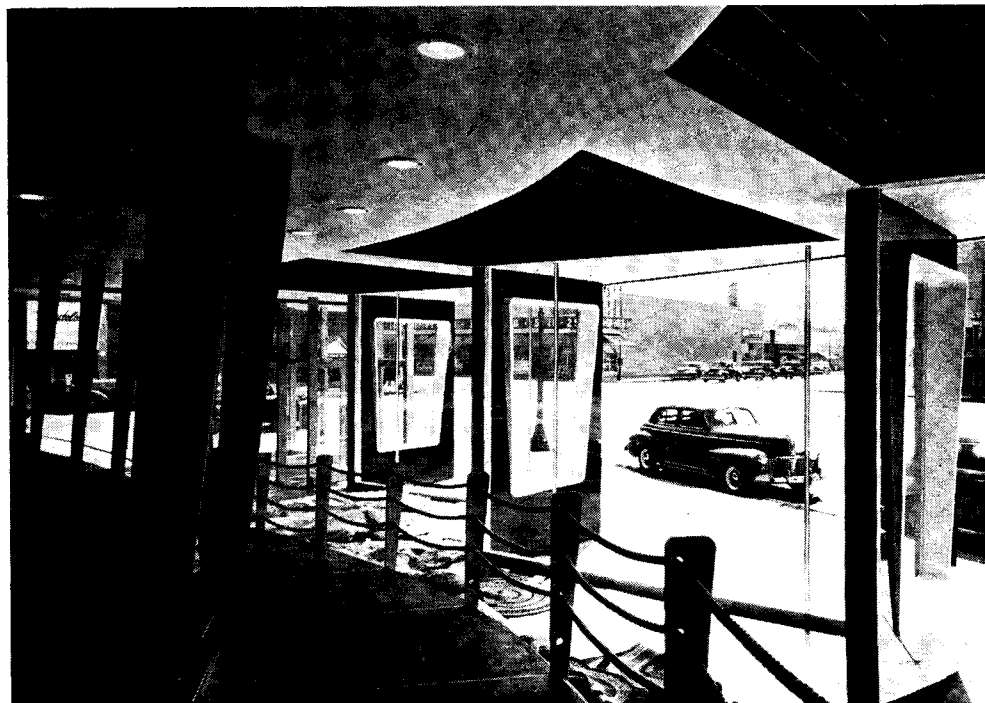
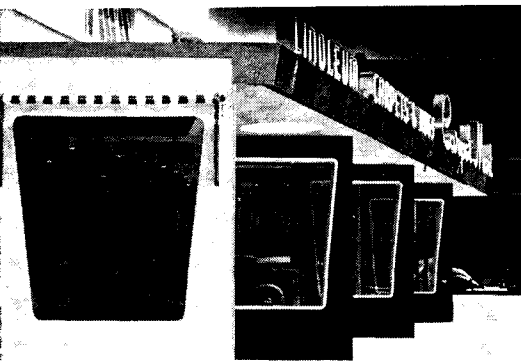

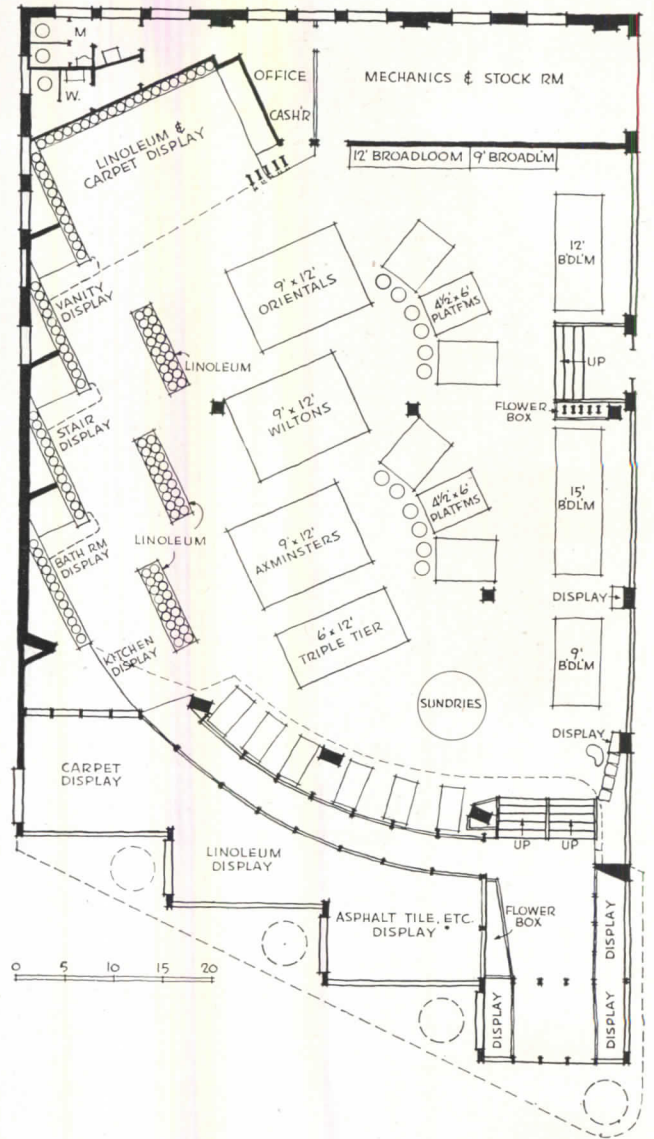
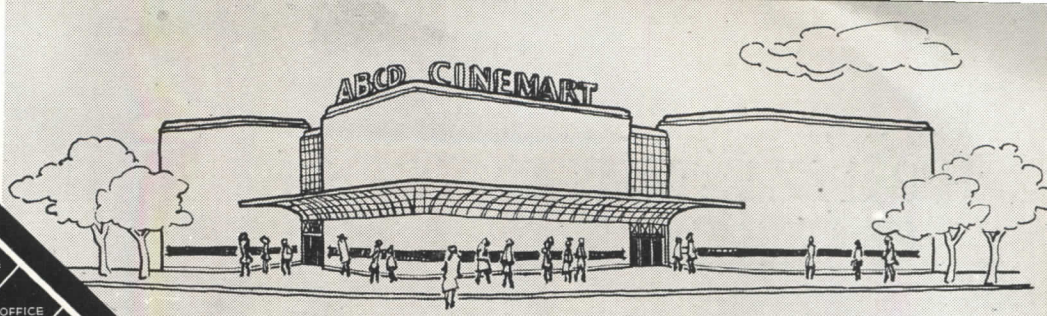
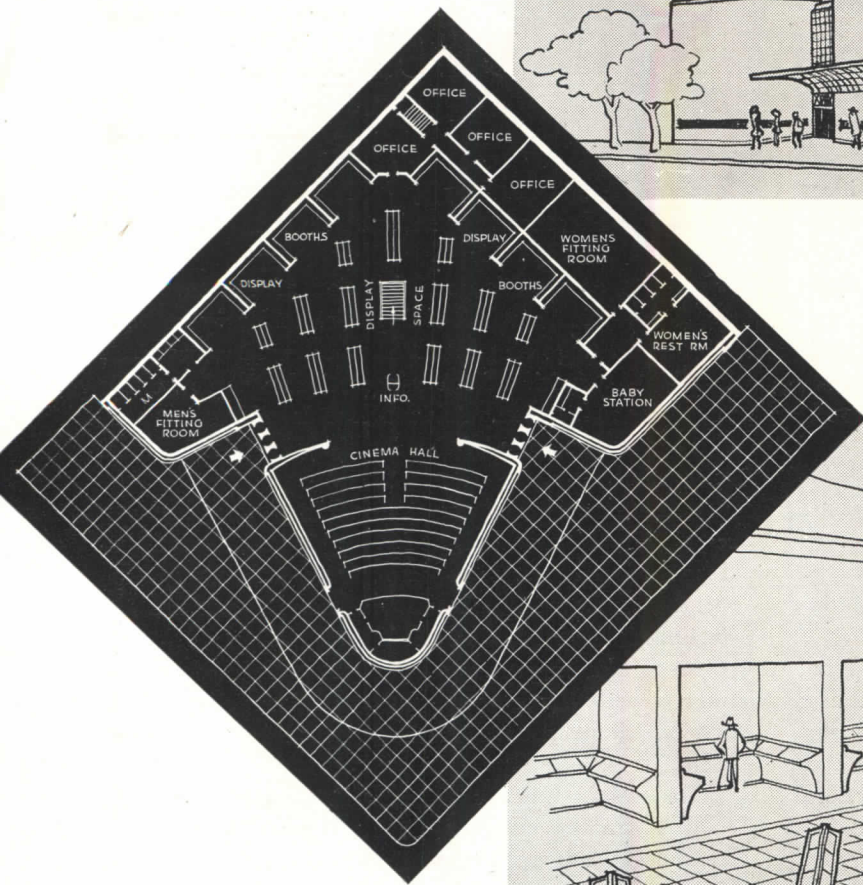

Photo above: recessed "high-hat" incandescent fixtures and cove lighting furnish special effects to linoleum section, and supplement general lighting scheme of the more open main sales area



Left: stairs provide direct access to selling level for patrons unimpeded by perambulators; carpeting is gray. Adjustable spot lights focalize special merchandise display and "compulsion" effects



0 10 20 30 40 50

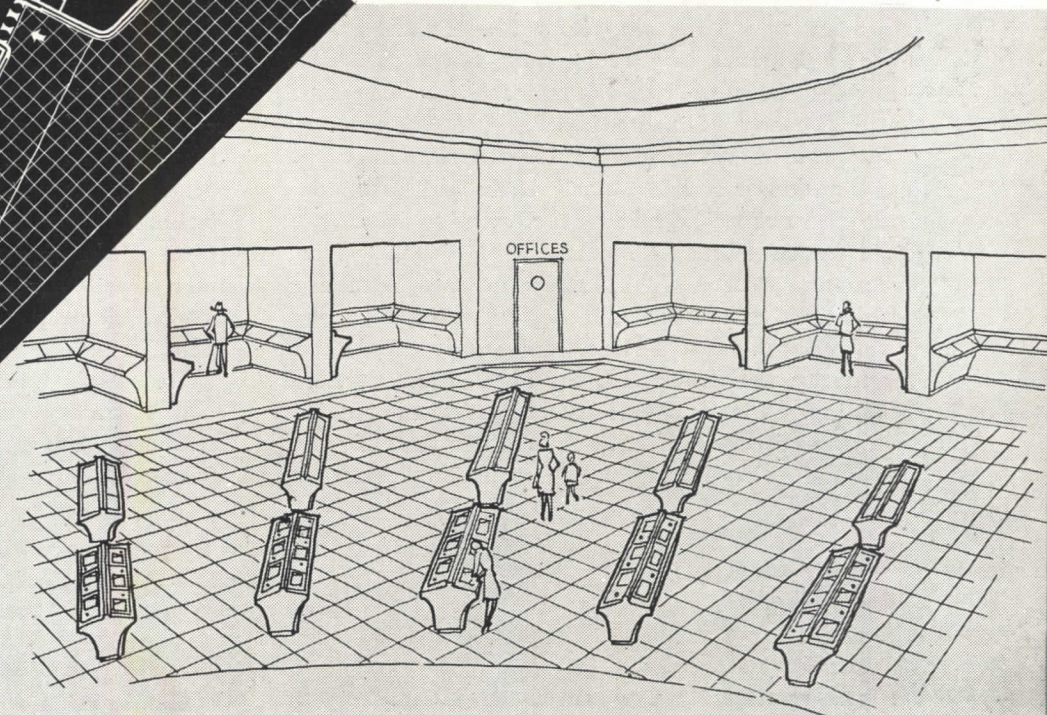

Facade contemplates "slot" show windows for Kodachrome presentations of merchandise. Basement will be leased to local or national distributor of minor merchandise not suitable for photo presentation

MERCHANDISING TWIST FOR ATOM ERA

CINEMART: A Proposal by Roderick Seidenberg, Architect

THE proponent says: "Recent technological developments are the basic argument for Cinemart — radio, sound movies, technicolor, microfilm, Kodachrome, television. Furthermore, it is justified by certain unmistakable consumer trends. There is a definite leveling of taste and conformity of standards between rural, suburban and urban communities — not incompatible with a general rise in taste (witness the new Montgomery-Ward catalogs). That the consumer expects the market to follow him into his ever more decentralized habitat is thus substantiated: during the last 15 years, large department store business increased about two per cent; that of mail-order houses and chain stores by some 200! Finally, such phenomena as increasing department-store branch locations; sales promotion of

cigarettes through mobile movie projectors; Montgomery-Ward's 2500 'Catalog Stores' throughout the country; all add up to some such combined and focussed scheme of marketing, through latest technological media, as here indicated."

The procedure contemplates a far-flung spread of Cinemarts (eventually international) designed to exhibit merchandise chiefly through the means suggested above, and supplemented by such actual samples of fabrics and materials as are feasible. Opportunities for collateral education in manufacturing processes and services such as air, rail and sea travel will be considerable. The proposal envisions hitherto unexampled facilities for centralized and comparative shopping; immense varieties and ranges of merchandise.

PRIZE-WINNING CHURCH DESIGNS

A WIDE variety of interesting current planning ideas and architectural forms was submitted in the recent competition which was sponsored by *Church Property Administration* and conducted by the Beaux-Arts Institute of Design.

There were two commendable objectives on the part of the sponsor of the competition: first, to stimulate interest in the problems of church design among young architects; and second, to inform administrators of churches of trends in contemporary church design by publishing the drawings in the national magazine, *Church Property Administration*.

The problem was to design a 300-seat church for any denomination or sect in a small community of the designer's own choosing, relating the edifice to the chosen site. Of special interest in the designs submitted are perhaps the variety of fenestration for non-distracting natural lighting and the emphasis on dramatic lighting of the chancel. Most designs were cleanly simple and structurally straightforward, devoid of ornamentation, depending on the use of materials, contrasts and studied proportions for their effects. Points of weakness of some of the non-prize-winning designs submitted were, as

in the Report of the Jury by Jedd S. Reisner:

"1. The entrance to the church itself in many cases was cramped and indirect.

"2. The composition and location of bell towers in relation to the church building were arbitrary and not placed with a sense of usefulness as much as with an idea of composition from one particular angle mostly in straight elevation. This resulted in an unfortunate placement of towers of the church when viewed from other sides.

"3. In many problems the solutions were hard to read because it was difficult for the jury to follow directions from perspective to plan and to determine where certain elements in plan were located in elevation. The jury has neither the time nor the opportunity to study involved planning during a judgment. It is always to the student's advantage to present a clean, simple solution which may be easily read in all its component parts."

The judges were architects E. James Gambaro, John T. Haneman, John C. B. Moore, Viggo F. E. Rambusch, Oliver Reagan, Robert J. Reiley, Jedd S. Reisner, Kenneth K. Stowell and Otto J. Tegen.

Awarded First Prize of \$150.00. Design by H. C. Stevens, Princeton University

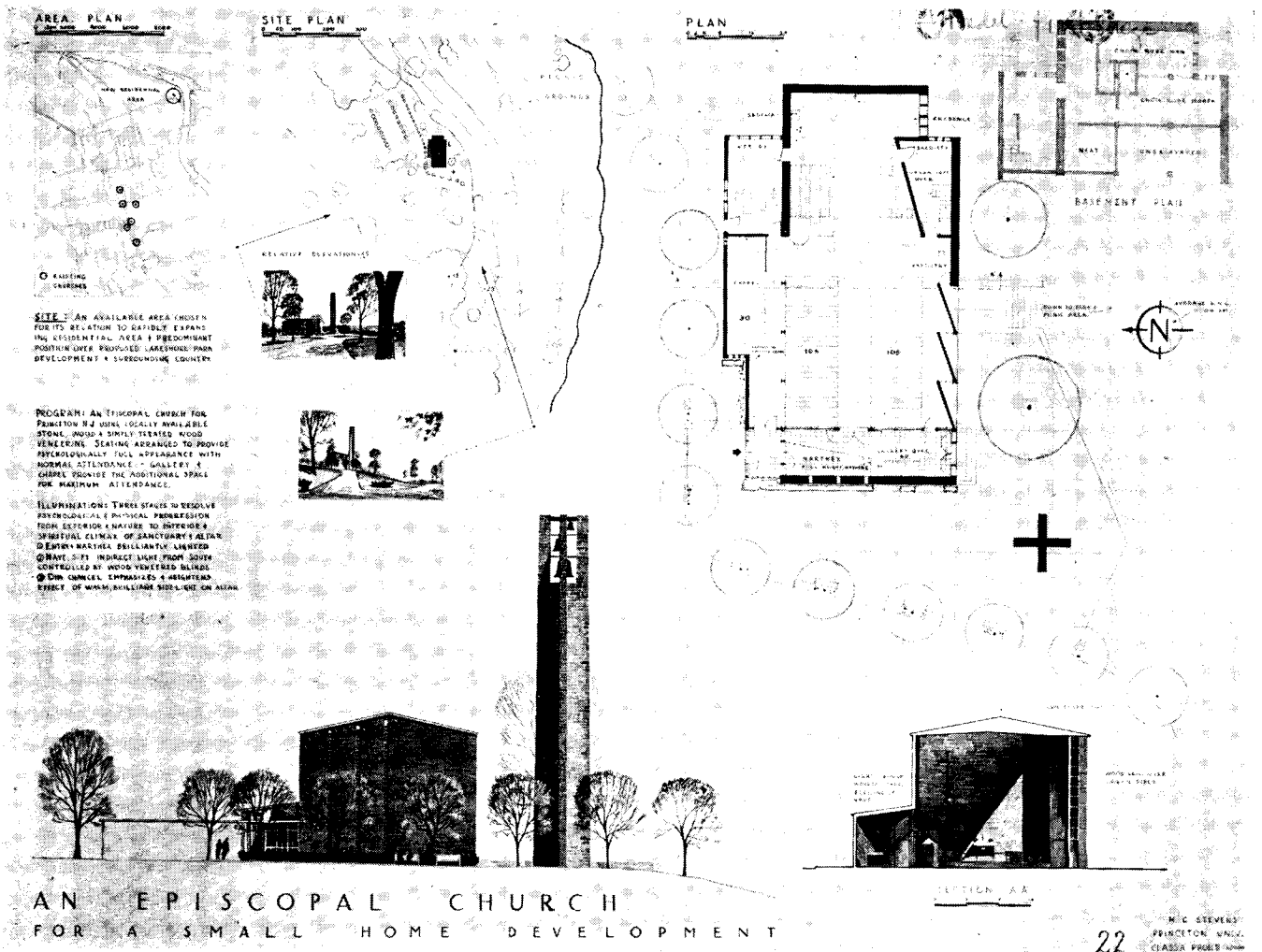

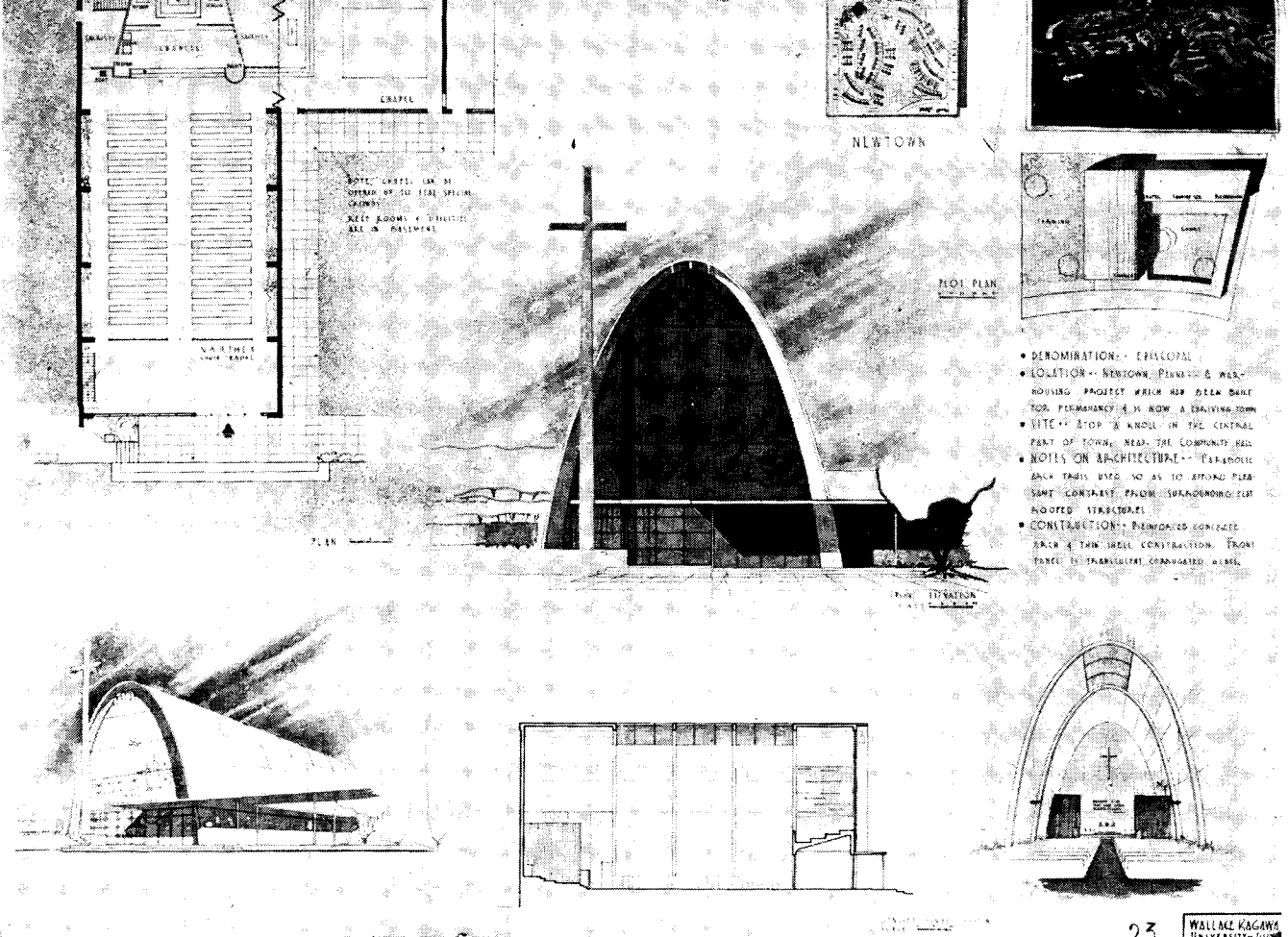

- DENOMINATION - EPISCOPAL
- LOCATION - NEWTOWN, PENNSYLVANIA & WELLS HOUSING PROJECT WHICH HAS BEEN BUILT FOR PERMANENCY IS NOW A TRAINING TOWN
- SITE - STOP & KNOW IN THE CENTRAL PART OF TOWN, NEAR THE COMMUNITY HALL
- NOTES ON ARCHITECTURE - PARABOLIC ARCH TUBES USED AS TO EXPLORE PLEASANT CONTRAST FROM SUPRACONCRETE/SLIST MOODS
- CONSTRUCTION - REINFORCED CONCRETE

Awarded Second Prize of \$100.00. Design by W. K. Kagawa, University of Illinois

Awarded Third Prize of \$75.00. Design by R. J. Smith, University of Illinois

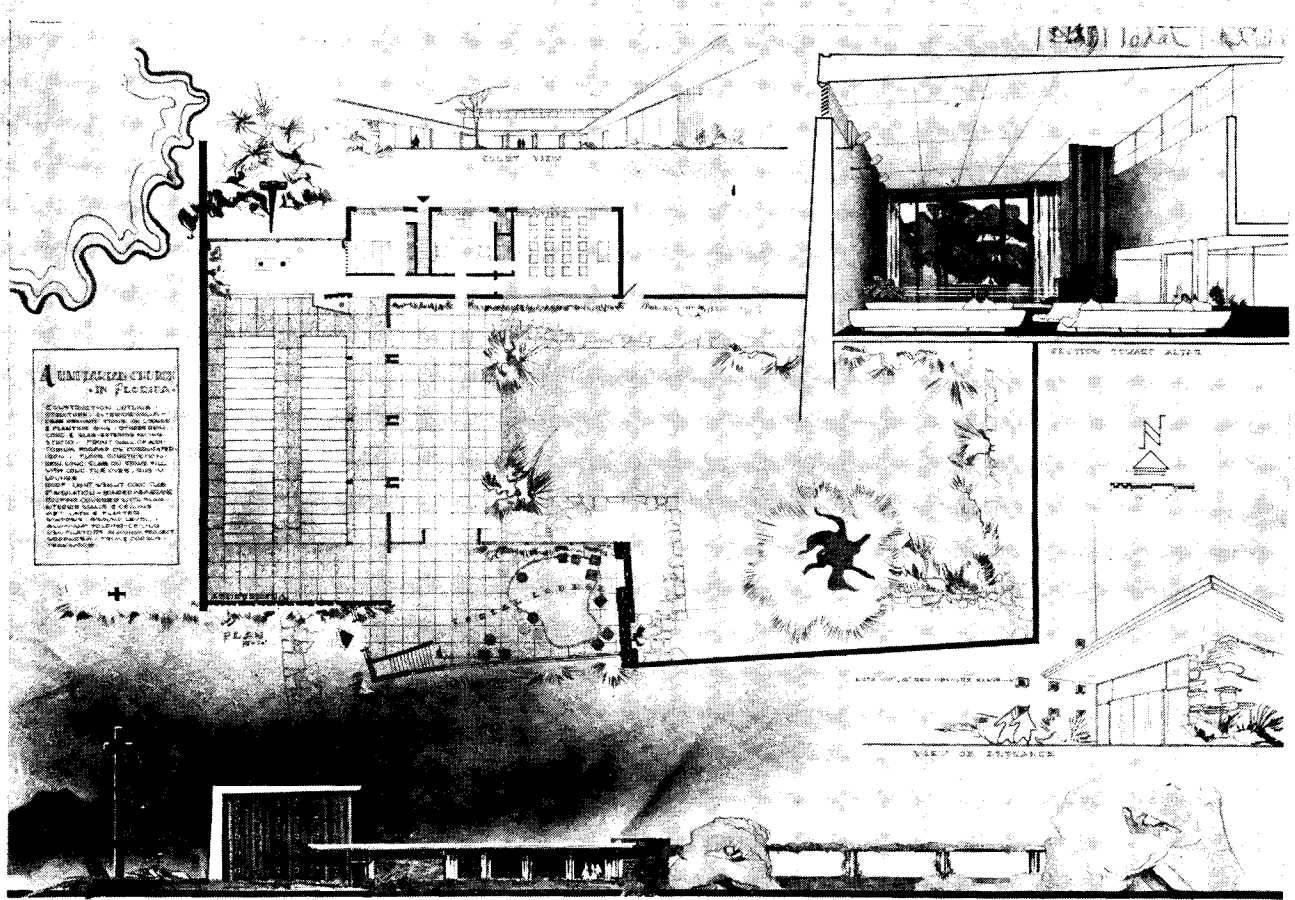

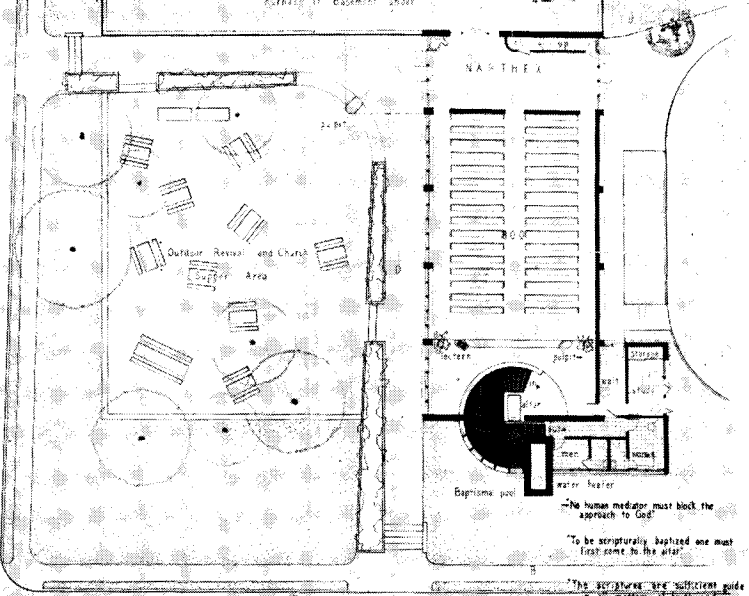
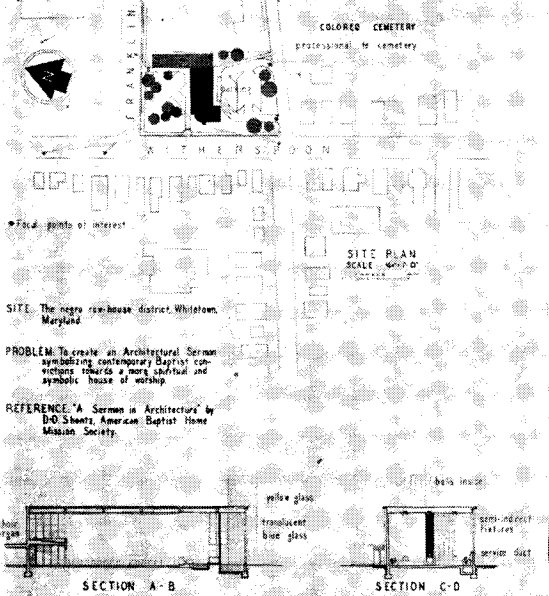

A NEGRO BAPTIST CHURCH 25 CARL MAPLES PRINCETON UNIV CLASS A PROJ PUBLIC FOR PROJ.

Awarded Third Prize of \$75.00. Design by C. F. Maples, Princeton University

Awarded Fourth Prize of \$50.00. Design by E. Jettmar, Catholic University of America

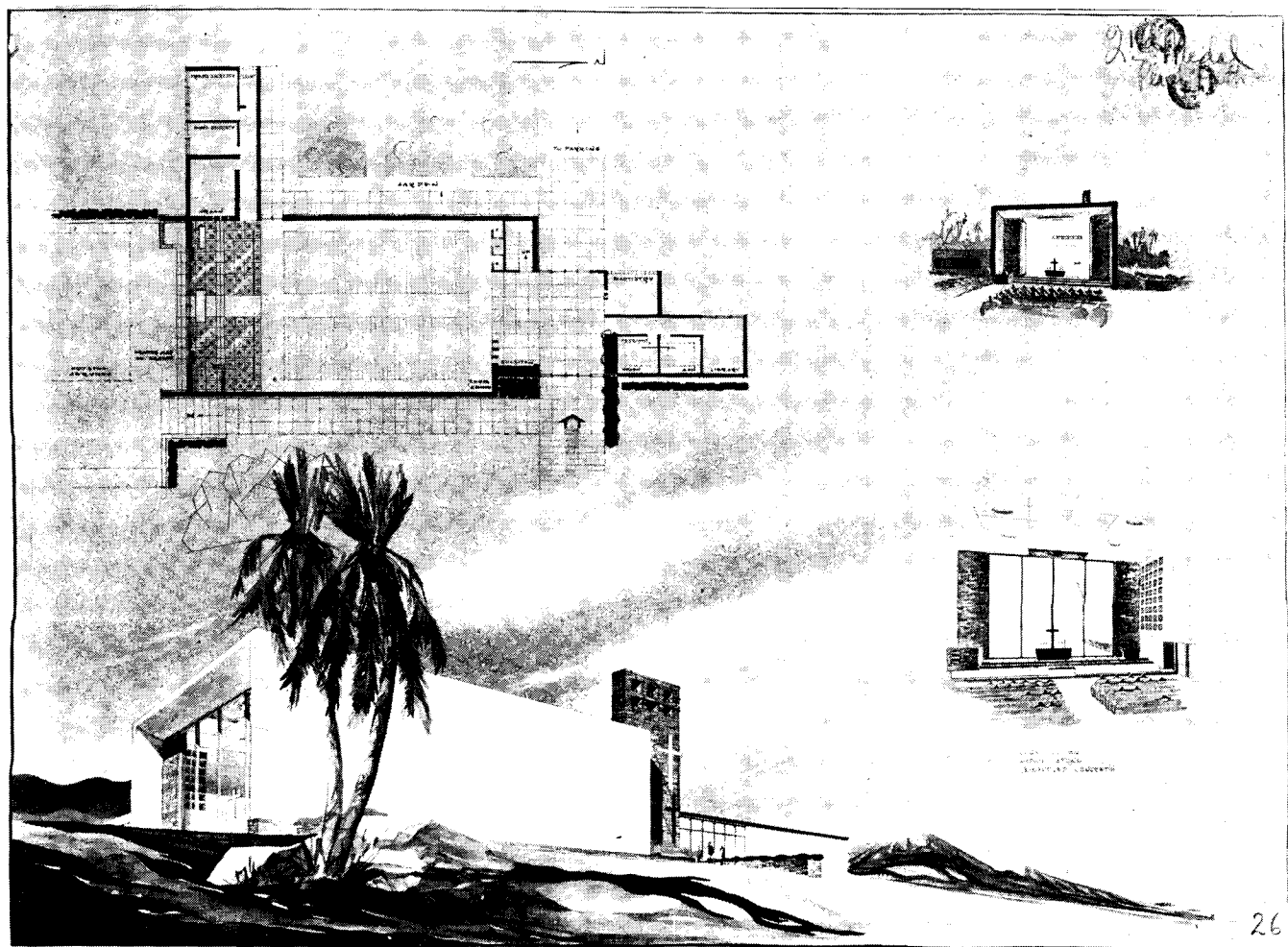

IN THIS SPECULATIVE SMALL HOMES
COMMUNITY THE PURPOSE OF A CHURCH
IS TO PROVIDE NOT ONLY A PLACE
OF WORSHIP AND A SYMBOL OF THE DEFORMA-
TION IT SERVES, BUT ALSO TO GIVE
ARCHITECTURAL EXPRESSION TO MAN'S SEARCH
FOR SOMETHING ABOVE THE BANAL REGRENTA-
TION OF HIS MANMADE SURROUNDINGS.

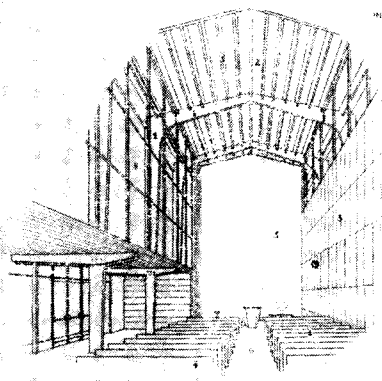
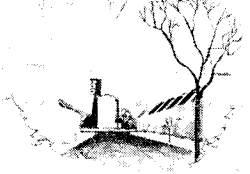
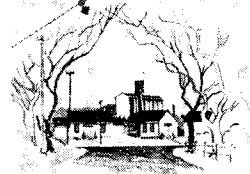
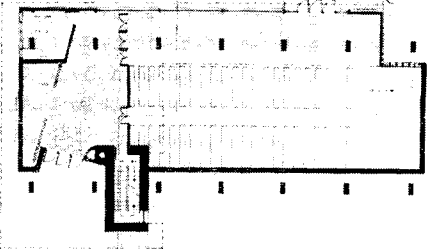
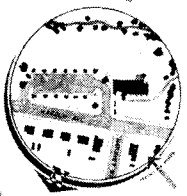
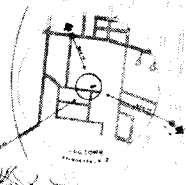

INTERIOR COLOR SCHEME

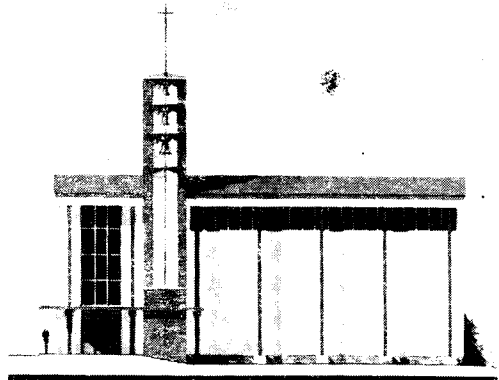
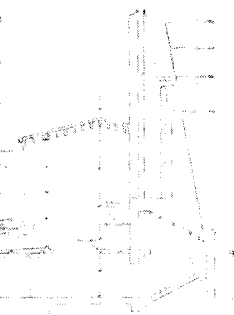

PRESBYTERIAN CHURCH FOR THE NEW DEVELOPMENT IN JUGTOWN

Awarded Fourth Prize of \$50.00. Design by W. D. Wilson, Princeton University

Design by Robert Hackner, University of Pennsylvania, which arrived after official judging, but which was highly commended

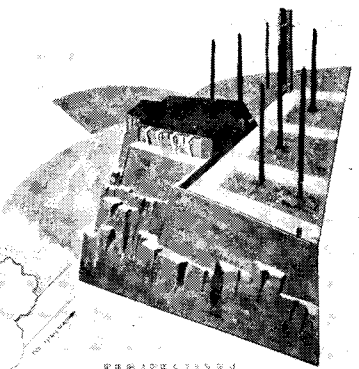
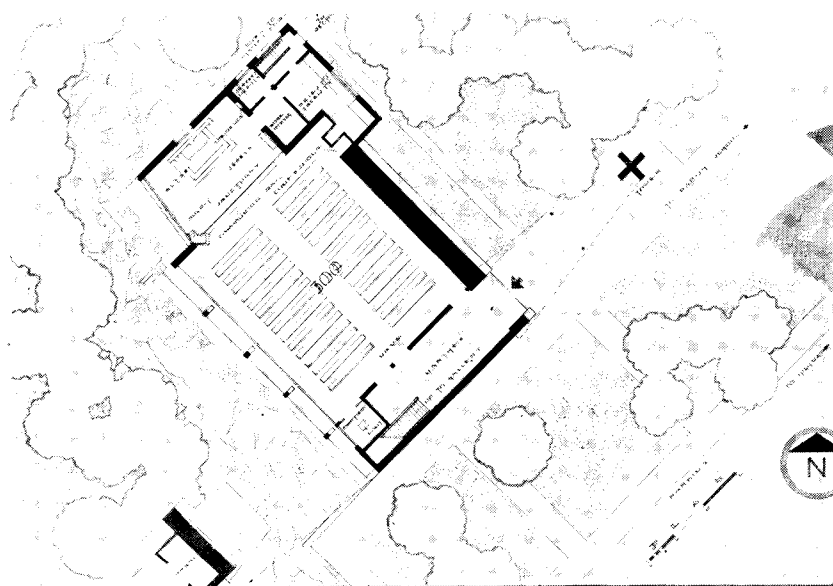

USE THESE PLANS ONLY
IN THE PRESENCE OF
SPECIFICALLY MADE
FOR THE BUILDING SERVICE

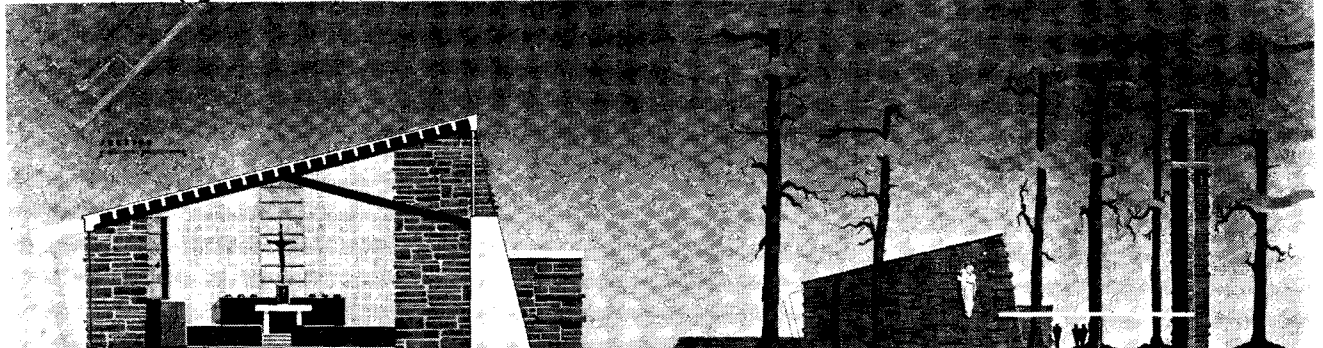

A CATHOLIC CHURCH FOR A RURAL COMMUNITY

EDDIE G. HALLNER
U OF PENNSYLVANIA
CLASS '38 PRO-2
A CHURCH

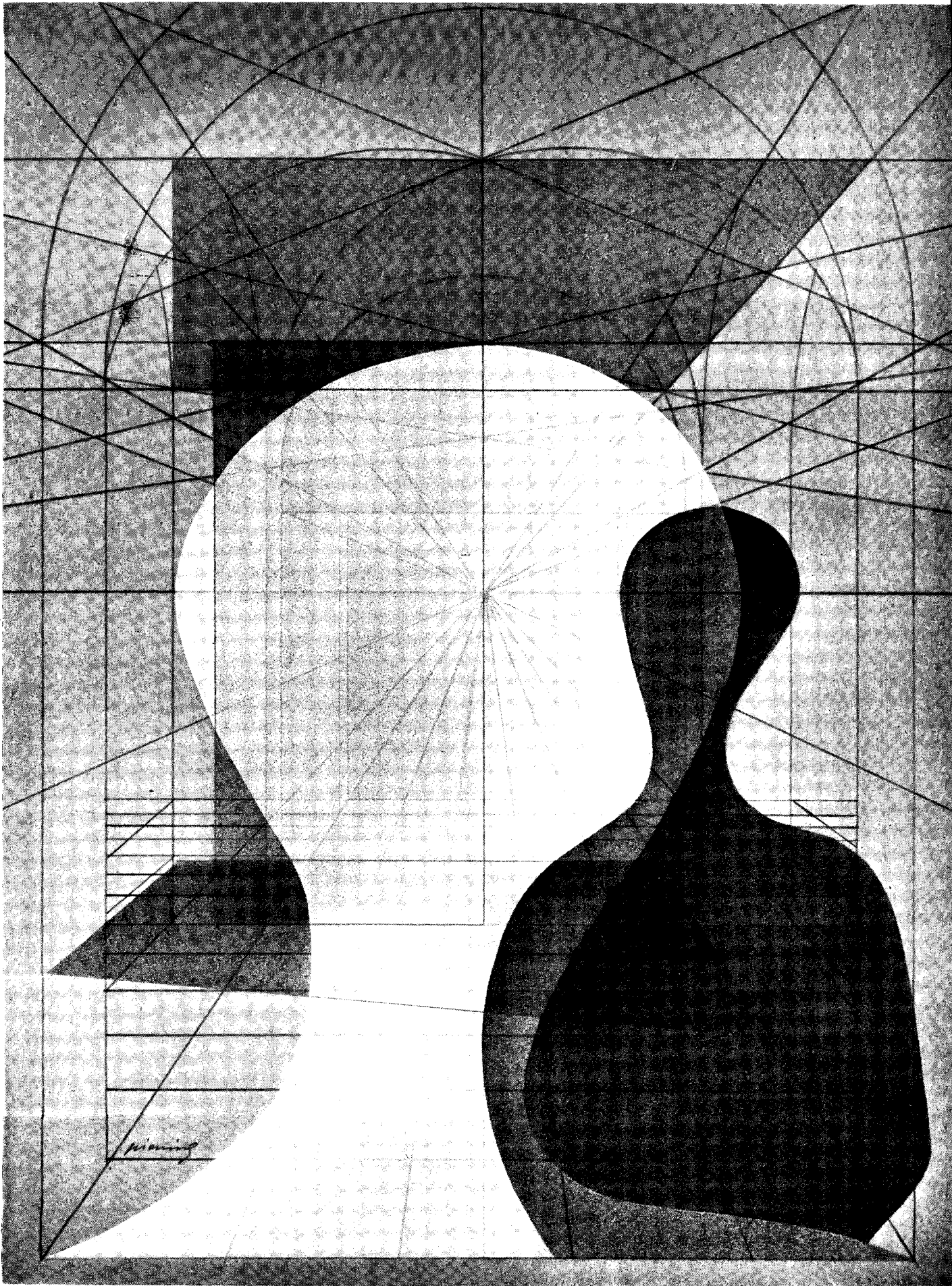

H O U S E S

ARCHITECTURAL RECORD'S BUILDING TYPES STUDY NO. 125

H O U S E S A R E F O R H U M A N S

THIS statement is, of course, axiomatic, even though it may be lost sight of by a designer who becomes intrigued with architecture for architecture's sake, or with ornamentation for virtuosity's sake, or with peculiar forms for originality's sake, for architects are humans too.

The fact that humans are such peculiar and varied creatures with so many prejudices, preconceived ideas about what they think they want and need in their houses, makes domestic architecture the fascinating study it has always been.

We, as architects, sometimes forget that our clients are human, with all that that implies of human frailties and perversities, and forget that prospective owners' desires are emotionally rather than rationally conditioned. Long association with certain architectural forms often have produced in their minds rather definite ideas of what their homes should be and look like.

"All know the influence of early home-teachings, youthful reminiscences and associations; if these were always of the simple, the beautiful and the reasonable in the home itself; if the very building never arose before the memory without confirming by its ever-speaking testimony the advantage of embodiment of these principles, and the harmony and loveliness of the result; how better armed to resist the temptations of a false and tricky taste, and to carry on the advocacy of the nobly true, the inventive mind of the artist and the appreciation of the amateur would be!"

A further analysis of our clients' motives seems indicated if we are to be successful in influencing their thinking to the extent of being able to produce designs which we feel our contemporary professionals will approve. *Pride* is one of the strongest underlying motives of most clients. Their houses are to them an evidence of their social position and their business success. They naturally want something they can show off to their neighbors, to show how smart and up-to-date they are. For this reason they are usually terrifically "style conscious" — style, that is, in the sense of fashion rather than "style" in a purist esthetic sense. In this lies the hope of the thoughtful creative architect, the modern architect, for as time goes on and the social and financial leaders in the community become more and more convinced that "it is smart to be modern," by just so much does the

sincere architect's task become easier in developing advanced designs.

On the other hand, the client's proclivity to be one of the herd, to follow the leader, may be the *bête noir* of the architect, frustrating his attempts to produce a more rational design, when the pace-setters seek social prestige and established security by harking back to feudal forms or to assumed ancestral homes.

This client gregariousness accounts for the fact that neighborhoods grow predominantly Colonial, Spanish, or Ye Olde English, for a client often will put up with both inconvenience and exorbitant expense in order to be in the style swim of the social group which he aspires to emulate. "Style," or rather "fashion," seeps downward, which, of course, accounts for row after row of pseudo-English or pseudo-Colonial small houses.

The hope for the future of domestic architecture is this very potent motivating force, the emulation of those who are looked up to as leaders in the community. The desire on the part of these leaders to assert their leadership by being different and advanced is another hopeful factor, for this desire to set the pace, to establish the fashion, gives the architect his greatest opportunity for creating houses nearer to his heart's desire. *"The pertinacity with which every newly built house, if in any respect out of the common way, is discussed, the curiosity shown by the strollers around it during the progress of the works, and very speedily the avidity with which any scrap or morsel of peculiar detail is seized upon and copied, are proofs of the awakened interest it excites."*

The public is being conditioned to new concepts of architecture, or to new emphasis at least on certain aspects of domestic architecture, through the printed word and the public press. Only a few years ago the consumer home magazines were highly critical of — and even ridiculed — the early efforts to create a more rational architecture. Today they vie with one another to show with adulation, though not always with discrimination, the latest works of the most advanced designers. As this popular movement grows, we believe that there will be more critical analysis of these houses, more help to the prospective client in separating the wheat from the chaff, more encouragement to the innovations and ideas that will prove sound.

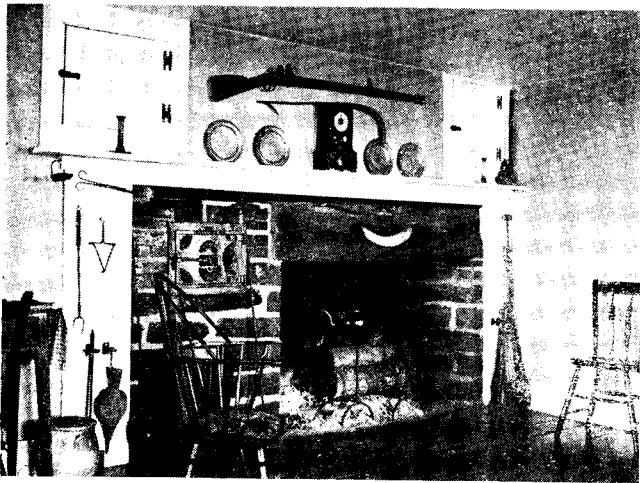

Photo Courtesy of Metropolitan Museum

Client predilections are based on a complex of emotional conditioning,

"The analytical sentiment of this age will, before very long, lead it to reject all that has not a purpose and a use -- a purpose of utility, a use in aiding harmony of effect; beauty only will be valued -- it will only be considered as such when so produced, and out of this sturdy determination to throw aside all not marking a meaning and intention, will result a grand, united, all-pervading influence, which at no very distant time will develop itself into a form and style. How -- the Giver of Genius best can show! But it will come, depend upon it; nor will silly, tricksied imitations, and obstinate adherence to unmeaning forms long delay it."

What will prove sound -- useful, economical, convenient, pleasing -- in the long run, time alone will tell. For judgments on the part of protagonist or public may be prejudiced by intellectual over-emphasis on one hand or by conditioned emotional responses on the other. Reason and emotion both enter into judgments and both must be taken into account.

Now we are in an age of especially active experimen-

tation, of efforts to improve our personal environment, of trial and error, and our judgments change with the times. Our developing contemporary style may well follow the course suggested by Pope for something quite different --

*... is a monster of so frightful mien,
As to be hated needs but be seen;
Yet seen too oft, familiar with her face,
We first endure, then pity, then embrace.*

What shall we embrace in house design? What are the criteria in judging a house? For a house can be judged from many points of view depending largely on the judge -- and on the times. The home owner himself, or herself, may judge on different bases at different times and under different circumstances. He may judge the house as a home -- an environment conducive to the happiness of the family. He may judge it as a financial investment, or as a badge of social standing. He may praise it for its convenient plan, condemn it for its costly upkeep

Home designs may stem from mistaken imitation of bygone styles, from



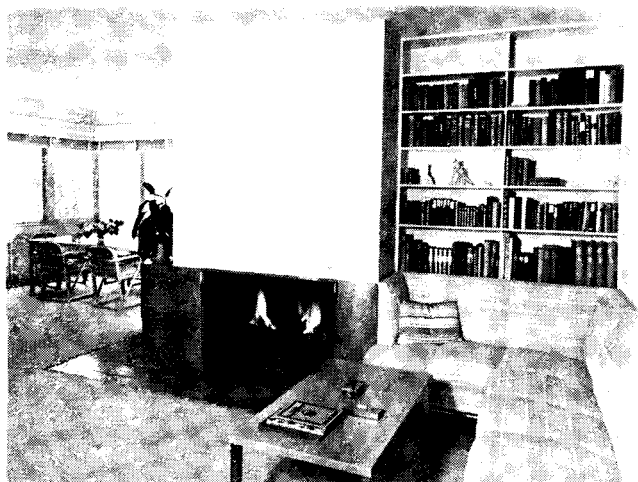

J. R. Davidson, Architect; Julius Shulman Photo

various social urges, and rational considerations of their ways of life

and repair. The engineer might judge it on structural and mechanical soundness or economy of means-to-ends; the banker, on quick and high resale value; the architect — depending on his age, training and previous condition of servitude — on its organic functioning, or on the refinement of its period detail. Nor are all architects entirely free from a tendency to confuse stylistic forms with efficient functioning. Non-functional planning, inconvenient or wasteful space arrangement, can be given the outward forms of functional architecture. This is especially true as "Modern" becomes a style and its forms can be imitated without understanding the philosophy and logic which gave rise to these forms. Unfortunately, it is easier to copy a cliché than to think a problem through.

To return to the possibility of establishing criteria for judging a house — or houses for humans — of establishing standards of comparative judgment (albeit those standards must be raised as advances are inevitably made) it might be well to list again the functions of the

ostentatious misplaced virtuosity, or from rational creative planning



G. F. Keck, Architect; Hedrich-Blessing Photo

house, thus to provide a scorecard of facilities, provisions, or characteristics that are essential or desirable.

The house should be designed to provide — efficiently, economically and attractively — adequate enclosed, semi-enclosed and open space so planned as to accommodate the persons and paraphernalia involved in all the activities of the family, individually and collectively. This includes:

1. Protection from the elements — from rain, storm, wind, fire, dust and changes in temperature.
2. Safety of persons and personal property from harm or loss by persons, animals or insects.
3. Privacy from intrusion by unwanted persons, sights or sounds. Individual privacy for each person.
4. Convenience in space arrangement, furnishing and equipment, for ease in use and to save time, steps, work; minimizing costs of operation and repair.
5. Flexibility. Adaptability to changing needs and uses.
6. Abundance of air, light (natural and artificial) and sunshine, with devices for their selective control.
7. Temperature and humidity control.
8. Sound control.
9. Complete sanitary facilities.
10. Facilities for rest, recreation, exercise, and cultural and social activities.
11. Facilities for food preservation, storage, preparation and consumption.
12. Means of dirt, dust, and refuse elimination.
13. Means of communication within and without.
14. Esthetic appeal — that elusive, hard-to-define character (beauty, if you will) that produces in the beholder and user a spiritual lift, a sense of well-being, of appropriateness of form, color and materials to their purposes.

Let our judgment of houses for humans be based on these 14 points.

"Constructive skill in building and ingenious adaptation of mechanical contrivances to meet the wants of domestic life, are the grand distinctive excellencies of this age; in no period of artistic history have we evidences of construction being so well understood, or of the use of materials so various and so scientifically adapted to their several purposes, as at the present time. It is the knowledge of the principles of design — the art of architecture — that seems wanting. . . . Yet we have construction superiority on our side; we have better tools to work with; more varied materials; scientific and reliable calculations upon which to base their proportions for purposes of strength and resistance, and the examples of by-gone beauty to work upon — surely, with all these advantages it cannot be that the dawn of a better intelligence will be long withheld!"

Strange as it may seem, the quoted paragraphs in italics were not written today — they were written by Gervase Wheeler, architect, in *RURAL HOMES*, published by Charles Scribner in 1852. It may be that from time immemorial houses have been for humans.

A SIMPLIFIED SMALL HOUSE

By Victor Civkin, A.I.A.

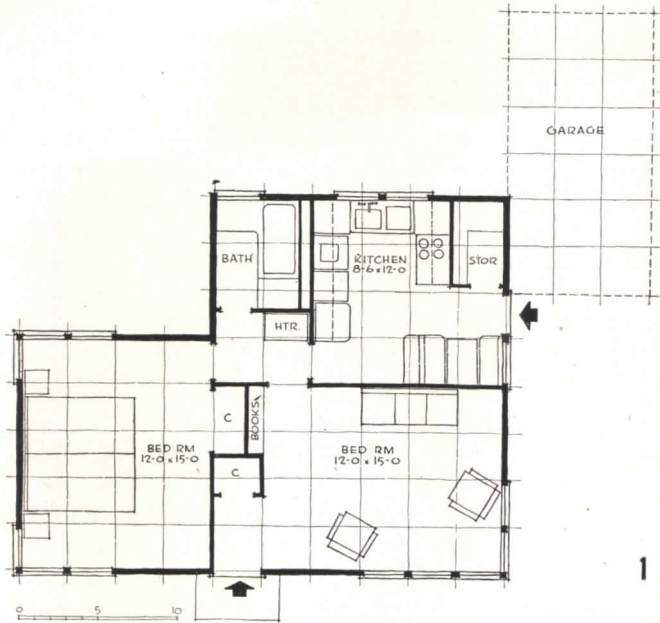

1

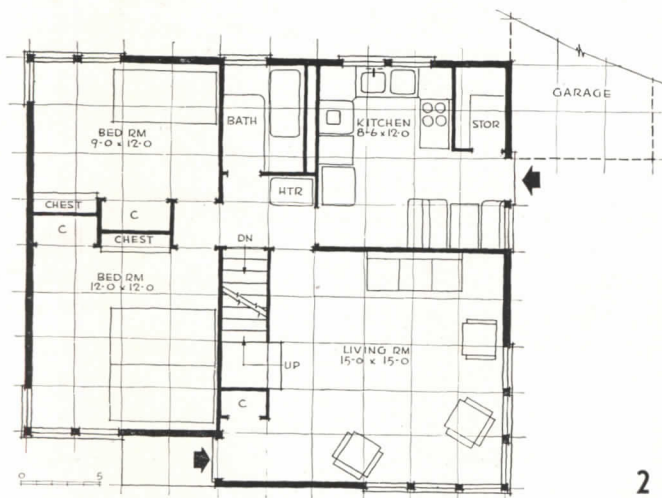

2

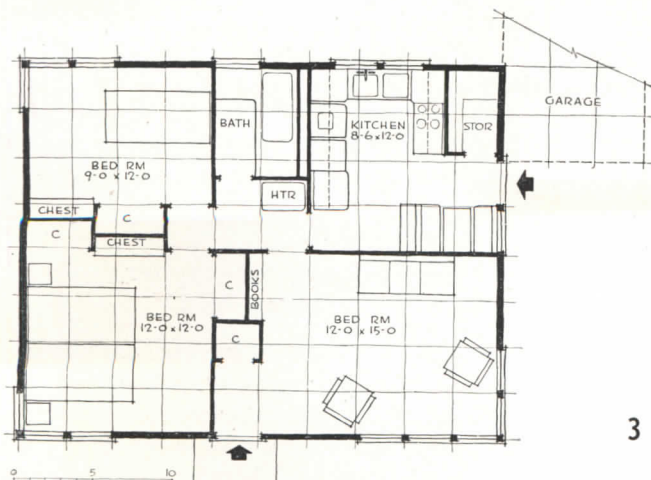

3

THE main idea of this study was to develop some kind of a system of small house planning which could be flexible enough to supply the client with desired variations and still have correlated designs. This system could be used by the designing architect engaged in developing communities of houses for sale or rent. The architect, using some system like this, could afford to supply the builder with variation of plans without excessive drafting, thus removing the builder's temptation to design the variations by himself.

The modulus can be of 36 in. or 39 in. or 4 ft. 0 in. Houses with one bedroom, two bedrooms, or three bedrooms on one floor are shown. They can be designed with or without a basement. Provision for additional bedrooms on the second floor can be made, and garages would be optional. In all variations, the kitchens and the bathrooms are identical. It seems to me that there is no reason whatsoever why small houses in this class should have variation in kitchens, bathrooms, or heating.

The plans are of different houses and should not be misconstrued as showing or recommending making additions to the house after it is built.

STANDARD PLANS WITH STANDARD VARIATIONS

1. The minimum one-bedroom house showing standardized room elements and possible garage location
2. A two-bedroom house having the standard bath, kitchen, and storage elements, but a living room enlarged by one module. Stairs lead up to additional bedrooms and down to basement storage or recreation rooms. Standardized chest and wardrobe units separate the bedrooms
3. A two-bedroom house with smaller living room, without attic or cellar
4. Opposite page: a three-bedroom house with living room similar to that of No. 2 and with standard variations of prefabricated chest and closet units

PLANNING SYSTEM

Closets, particularly in plastered houses, may cost as much as a room itself. There is no reason why a closet has to have 5½ in. walls plastered on both sides and trimmed with a base and casing around the doors, so this particular system contemplates factory-made closets of standardized size and shape comprising chest and mirror elements (A), hanging and shelf space (B), and linen or coat element (L), independent of the house structure. Sketch of a model for a three-unit prefabricated bathroom suitable for standardized houses is shown at the left.

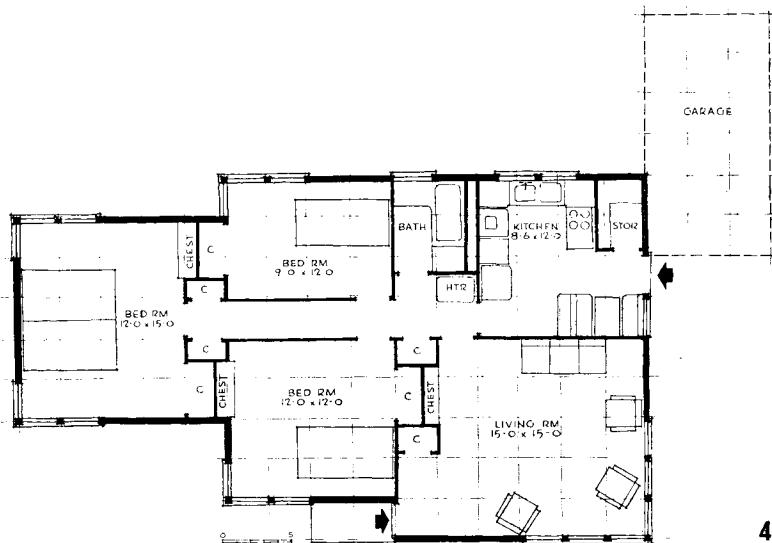
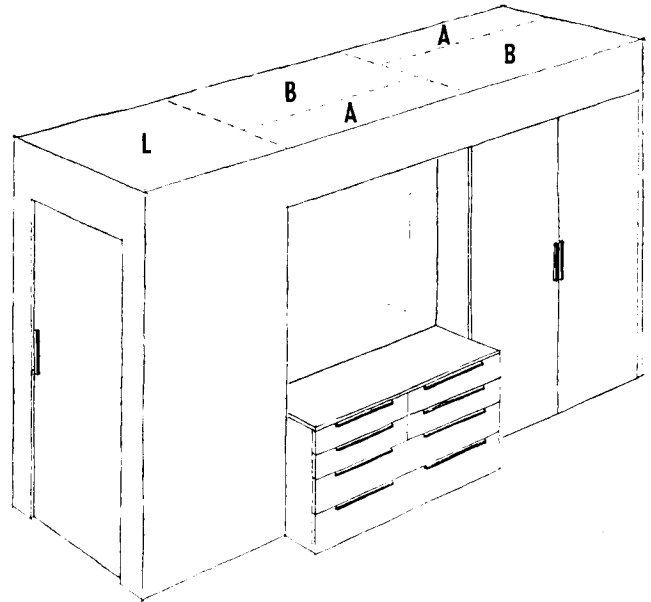
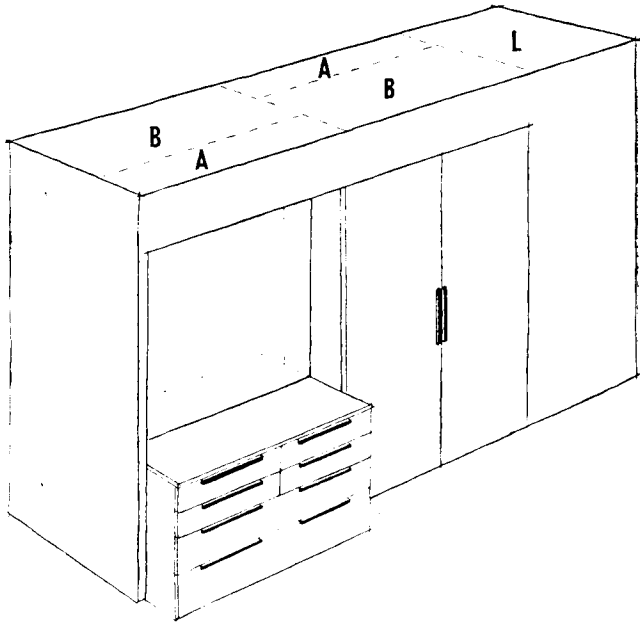
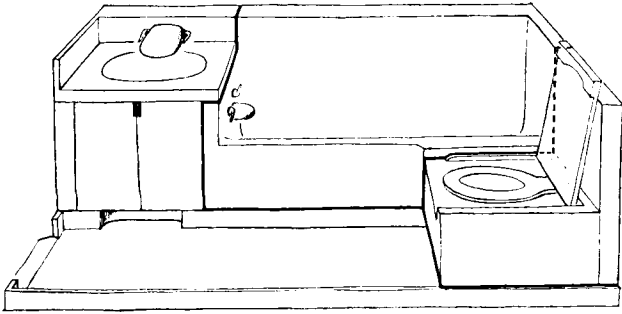

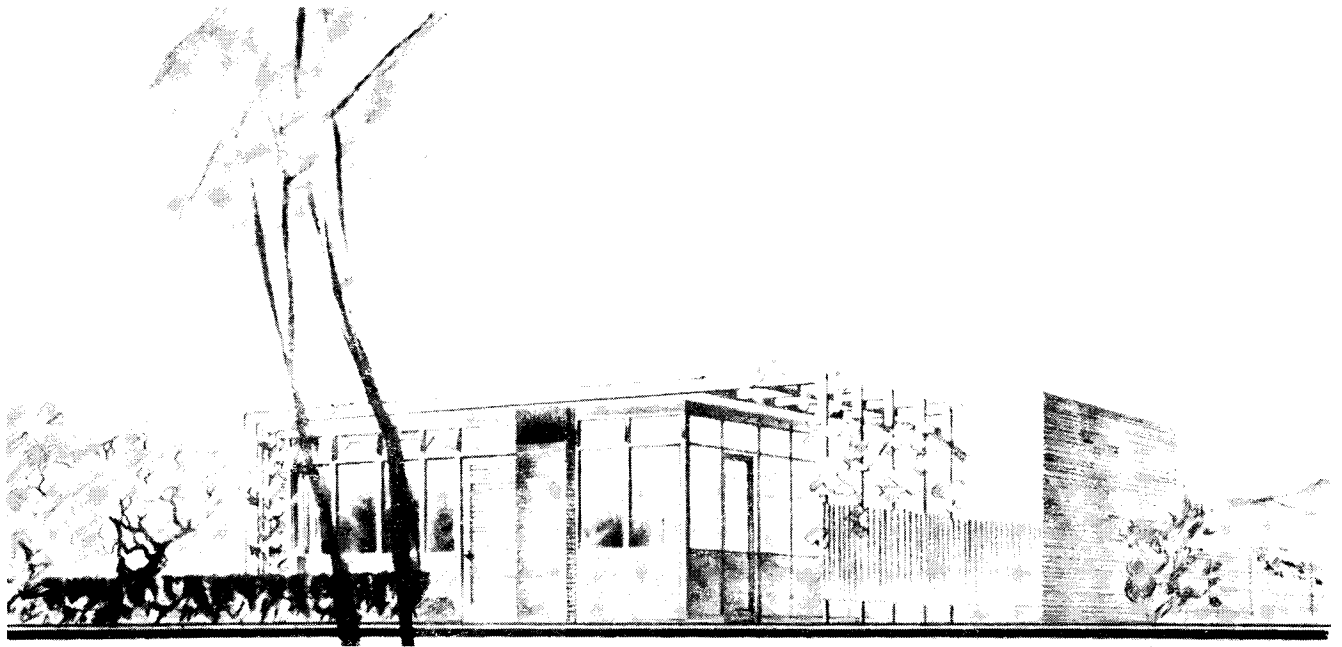

HOUSES FOR AN ARIZONA COMMUNITY

"EL SIGLO APARTMENTS," TUCSON, ARIZONA

William Wilde, Architect

John M. Harlow & James F. Hosteller, Landscape Architects; William and Sylvia Wilde, Design Consultants

An apartment might be defined as a dwelling unit on one floor, and while we usually envision the apartment house as a many-storied structure with similar apartments one over the other on successive floors, there is no reason why apartments can't be adjacent to one another on ground level. In any event, that is the reasoning of the owners of "El Siglo Apartments," the Oshrin Building and Development Co., and their designers. These standardized dwelling units, houses, or apartments, as you will, are designed for rent. The units, having one, two, or three bedrooms, are planned for convenient and economical living, making the maximum use of space and providing flexibility for varied activities within the space limitations. An unusual number of built-in features makes these units livable with a minimum of furniture, as the details on page 127 so clearly show. (The owners plan to rent these units furnished.) Wardrobe and closet space are arranged with special care. Designing has been on a modular grid pattern of 2 ft. 8 in. squares, for brick and panel construction. The floor is a concrete slab, reinforced with wire mesh, over a gravel base. Wooden roof panels are supported by walls or steel girders, and are

covered with insulation board and built-up roofing.

The designers' objective has been to develop a plan which would lend itself to the standardization of all or many of its component parts so that the units could be built either entirely or partially by prefabrication methods. A processing chart has been worked out which indicates the possibility of completing a house in 14 days of site work if parts are there on schedule.

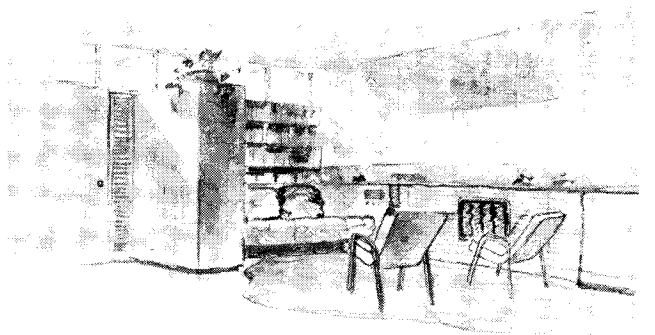

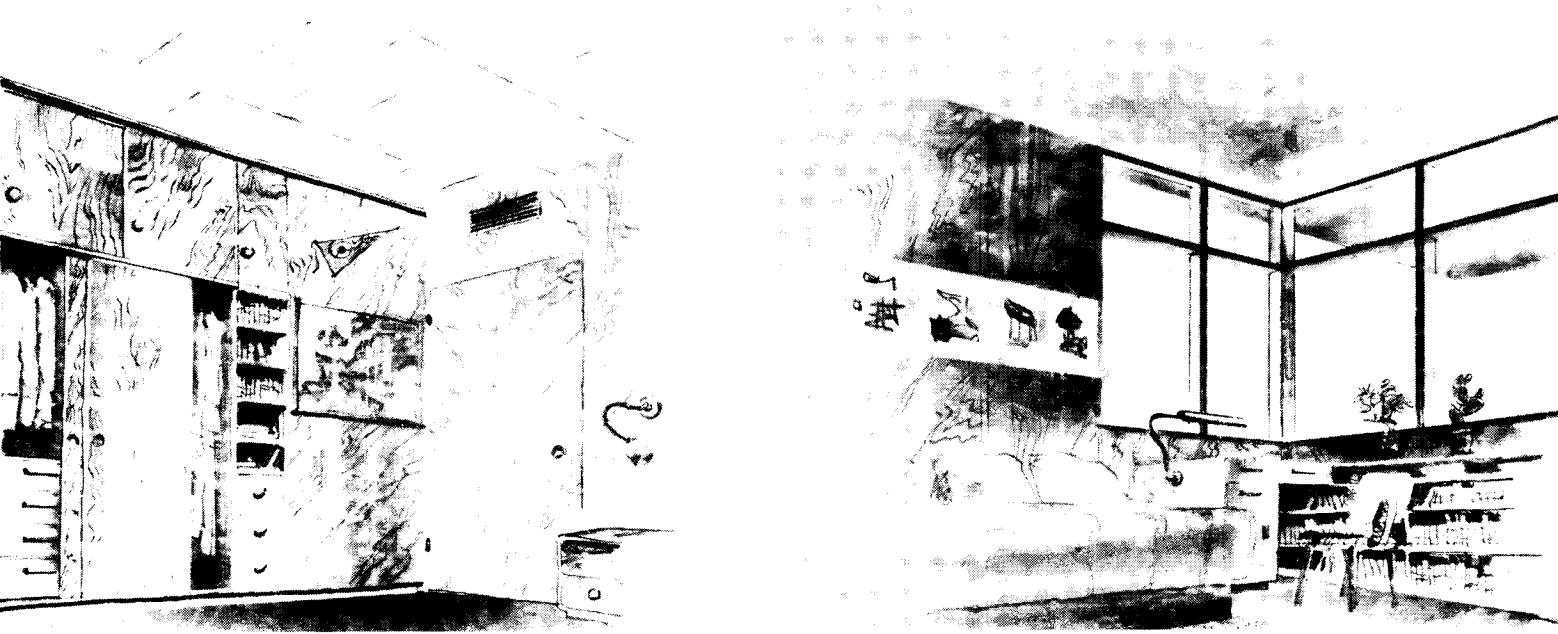

Perspectives of children's bedrooms showing wardrobe walls, bed, desk and bookcases



Above: perspective of a three-bedroom unit. Below: plan of a basic three-bedroom unit. Right: perspective of bedroom. Opposite page: sketch of living room showing electric radiant heater

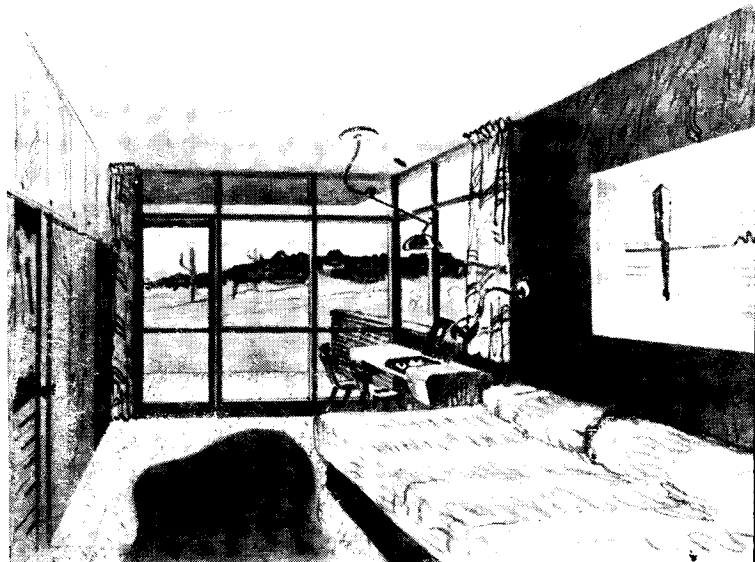
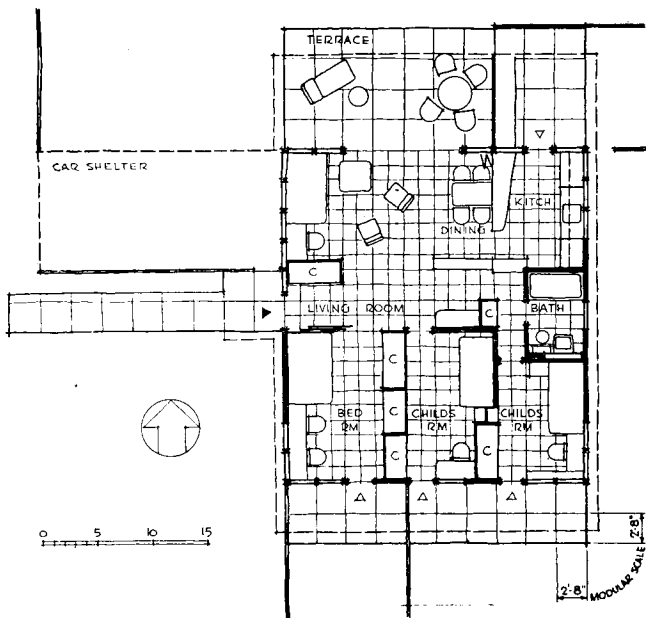

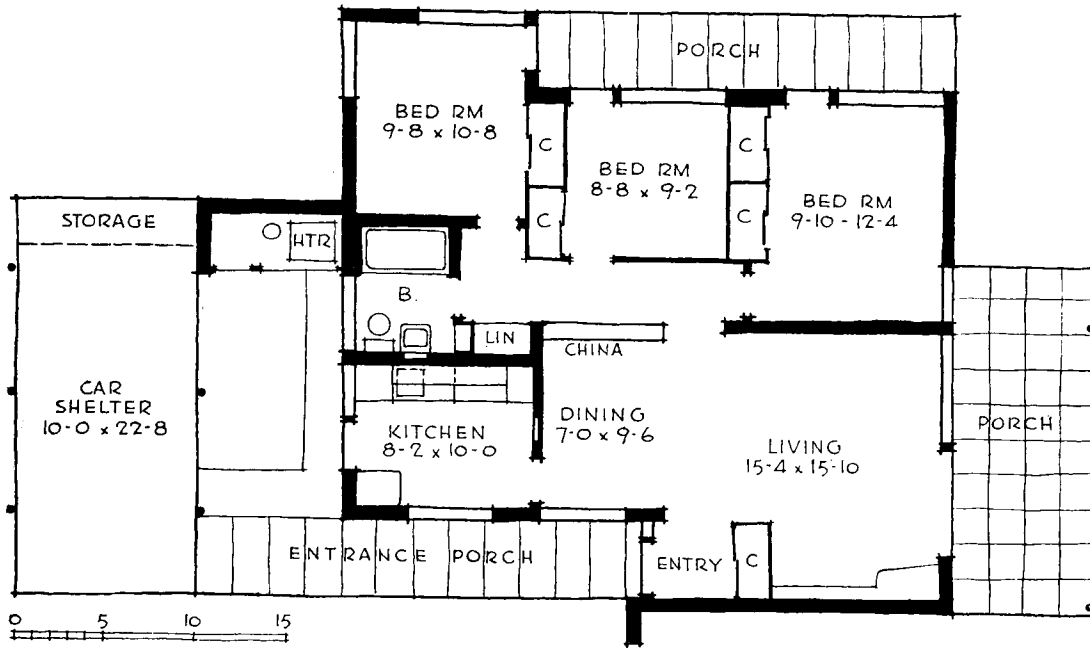

Above: revised plan of a three-bedroom unit designed to meet FHA requirements. Below: preliminary landscape plan showing possibilities of staggered units to avoid monotony

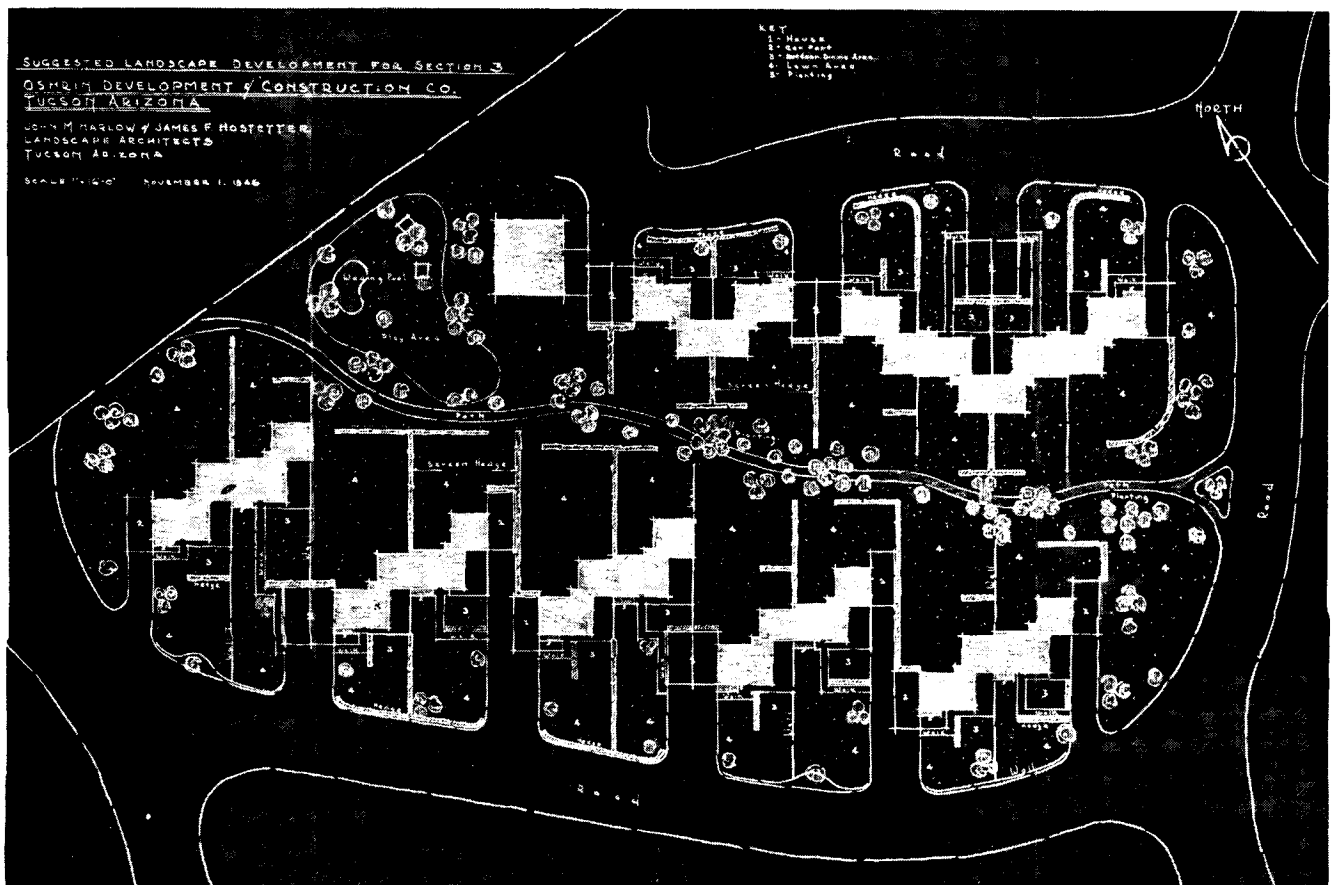

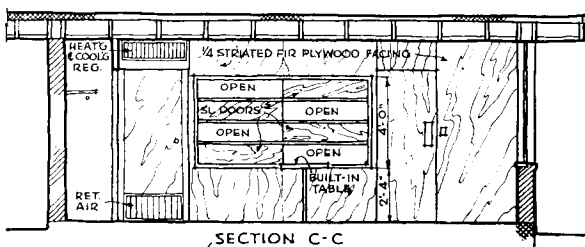
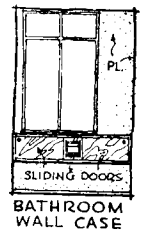
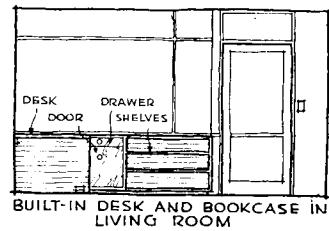
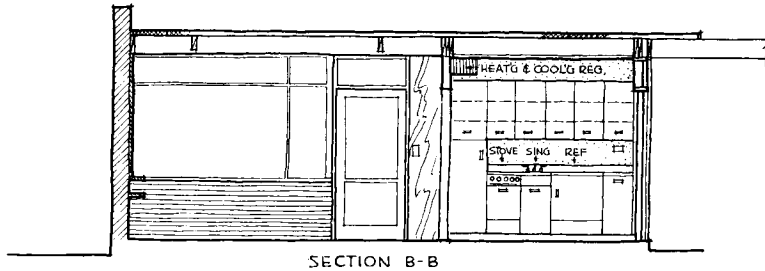
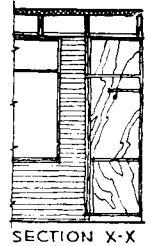
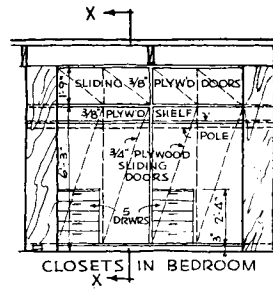
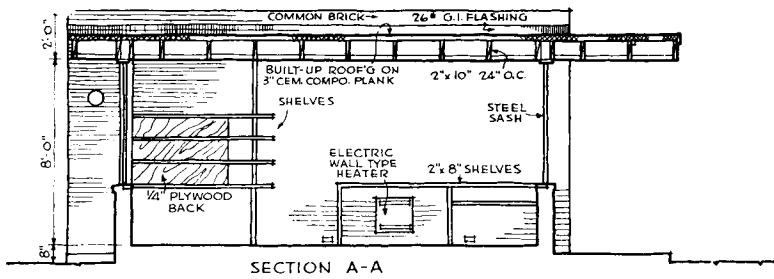
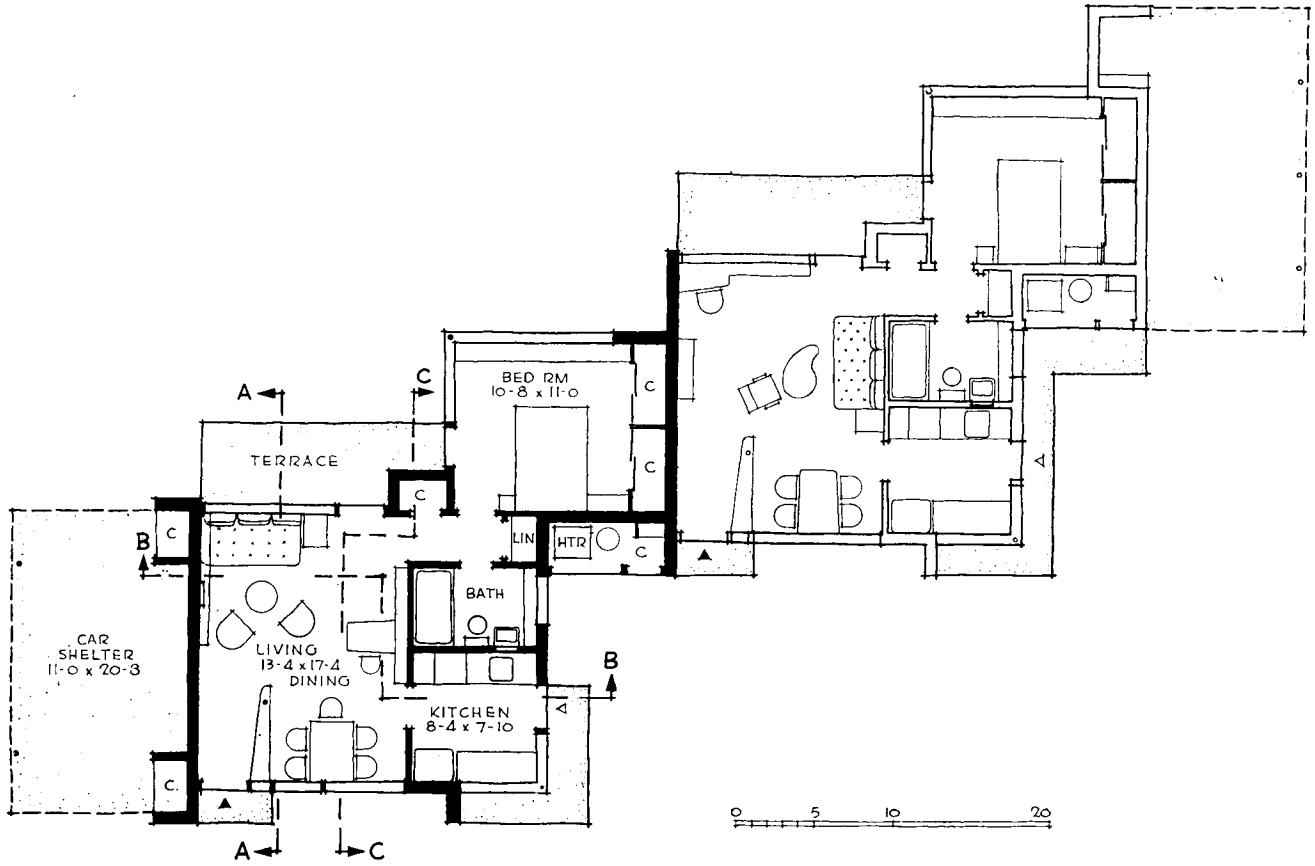

Plans and details of one-bedroom units showing placing of furniture and the many unusual built-in features, wall closets, bookshelves, cabinets, table, heater, and kitchen and bath cases



COMPACT PLAN FOR THE NORTH, IN TWO VERSIONS

Sargent-Webster-Crenshaw & Folley, Architects

CONVINCED that they had something in this contemporary version of the compactness required for economy in the Syracuse climate and a high-cost era, two members of this firm of architects used the plan for their own houses, and then found its merits endorsed with a prize in the New York State Architects' Convention.

Unique and satisfactory features, they believe, are the foundations and heating systems. Concrete slabs, 8-in. thick, float on gravel fill, carefully drained by tile around the exterior. Top of slab is foil insulated; oak flooring is laid over 2 by 2-in. sleepers. Baseboards at exterior walls are slotted to permit air return beneath the flooring to a center trench, thence up into heater for recirculation from high-level registers. "After six years, the floors remain very comfortable and show no signs of frost movement."

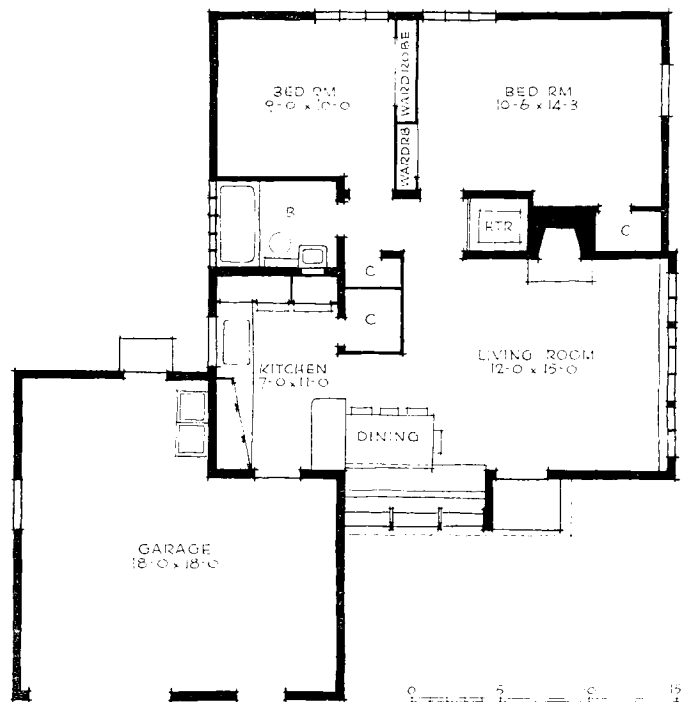
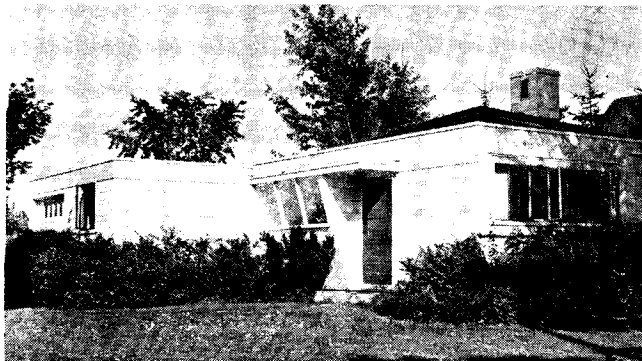

Left the Folley house has white horizontal siding; the exterior of Mr. Crenshaw's is similar, but with stained battens. In plan the major differences are an additional window and alternate location of the minor entrance to Mr. Crenshaw's garage

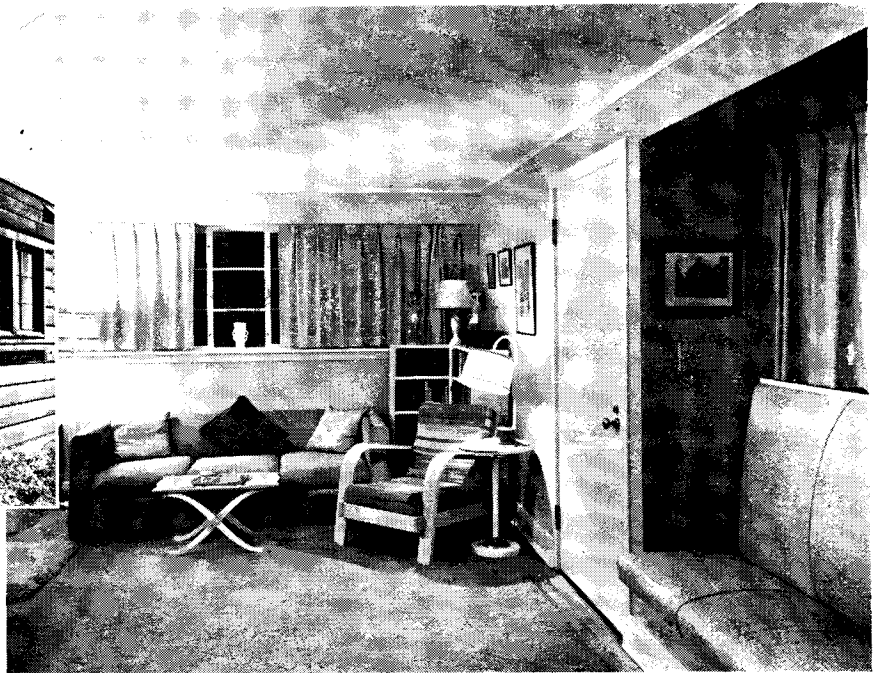
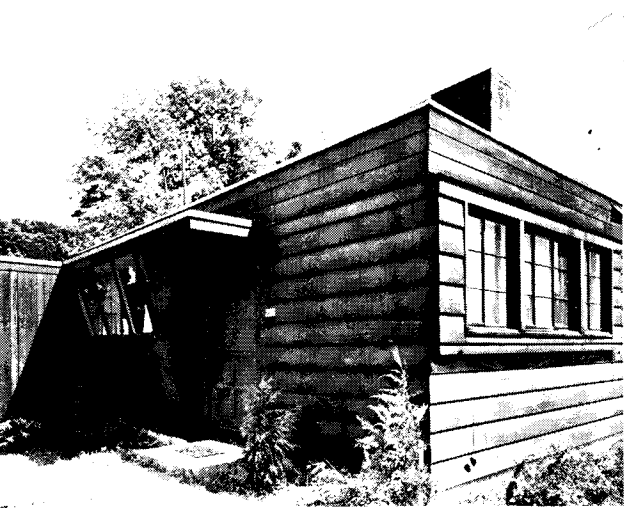

Robert Ask Photos

Above and right: note how window seat bridges living room and dining area. Folding panel sets up formality or abolishes it with a shove for open convenience

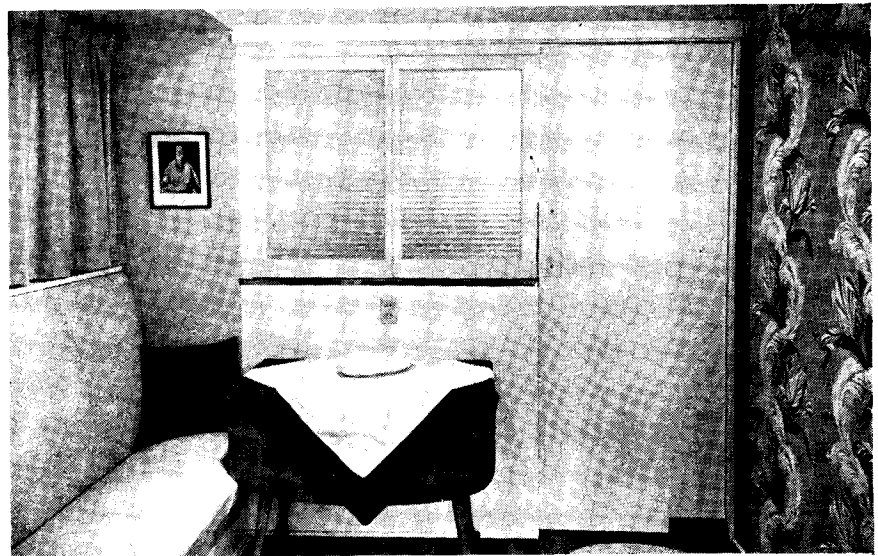
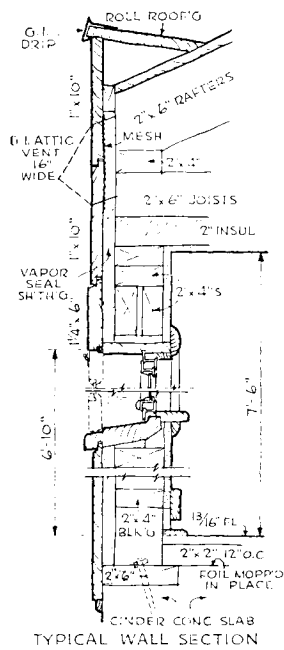

Note in the section above the space at baseboard and arrangement of plate and blocking to permit return of air between sleepers to central trench and heater

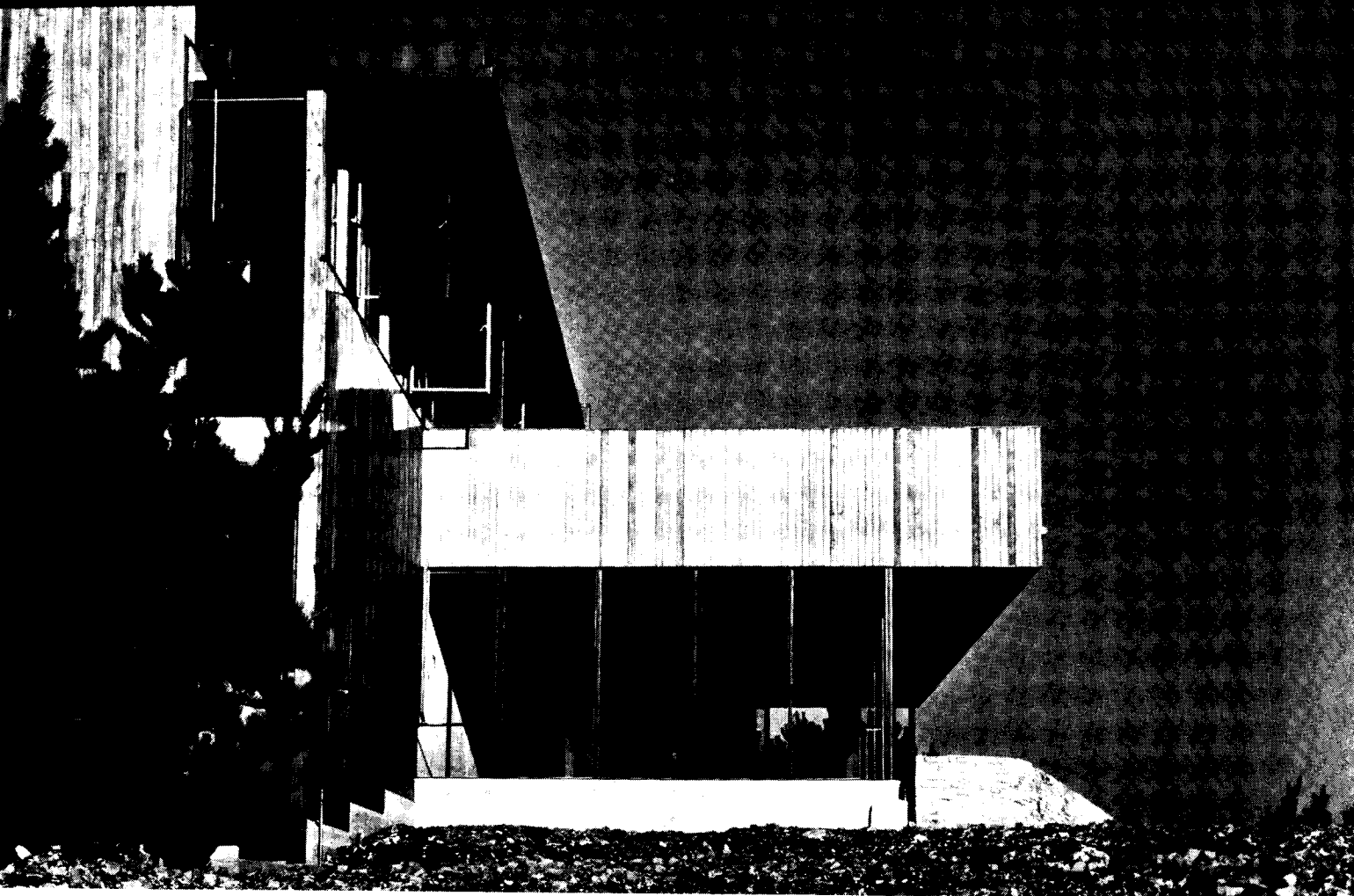

Luckhaus Studio Photos

CALIFORNIA HOUSE WITH AND WITHOUT A VIEW

Residence for Mr. and Mrs. William Davey, Monterey Peninsula, California

Richard J. Neutra, Architect

TOPPING a site of several pine-studded acres on the Monterey peninsula, this house embraces, and at the same time rejects, one of California's supercolossal views. Living and sleeping areas have the Neutra full-glass walls oriented to view and winter sunshine, but work rooms, the studio and writing study, resolutely turn their backs to this distracting enchantment.

The exterior is of naturally treated redwood with steel sash, metal gutters and downspouts in dark red oil paint. The patio wall and paving are of random-size Monterey flagstone. All interiors are finished in enamel-coated wall fabric, and floored with eggplant colored battleship linoleum, except for the living room, which is carpeted.

Panoramic view includes Point Lobos, west, fishing harbor of Monterey Bay, north, a wooded ridge, south.

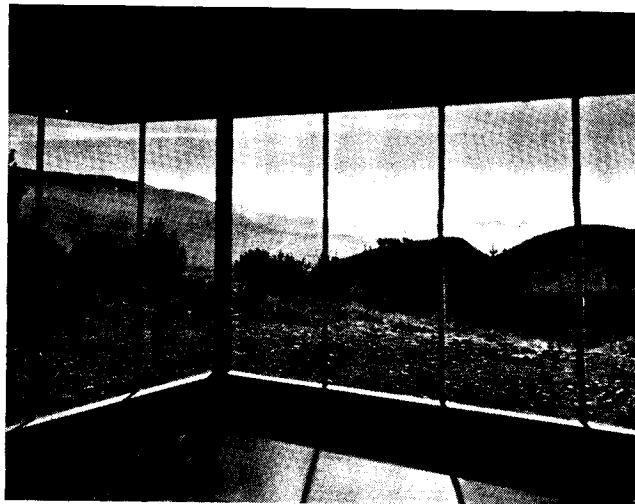

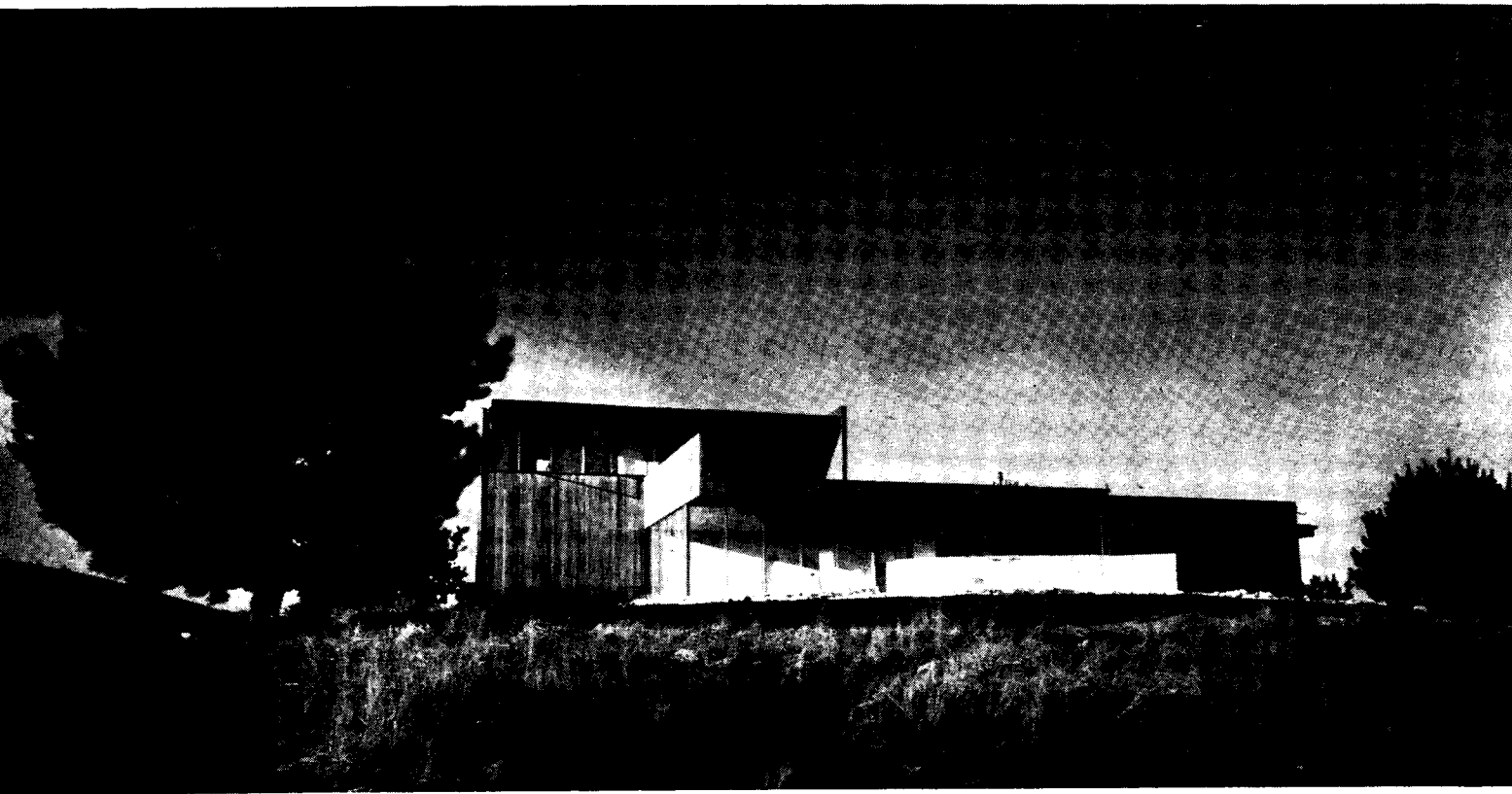

Bedrooms and bathrooms (second floor plan omitted) are arranged in two suites, which include dressing facilities. An open deck, accessible to both, has been placed on the upper level, behind a wind screen. The gallery connecting separate units has soffit lighting

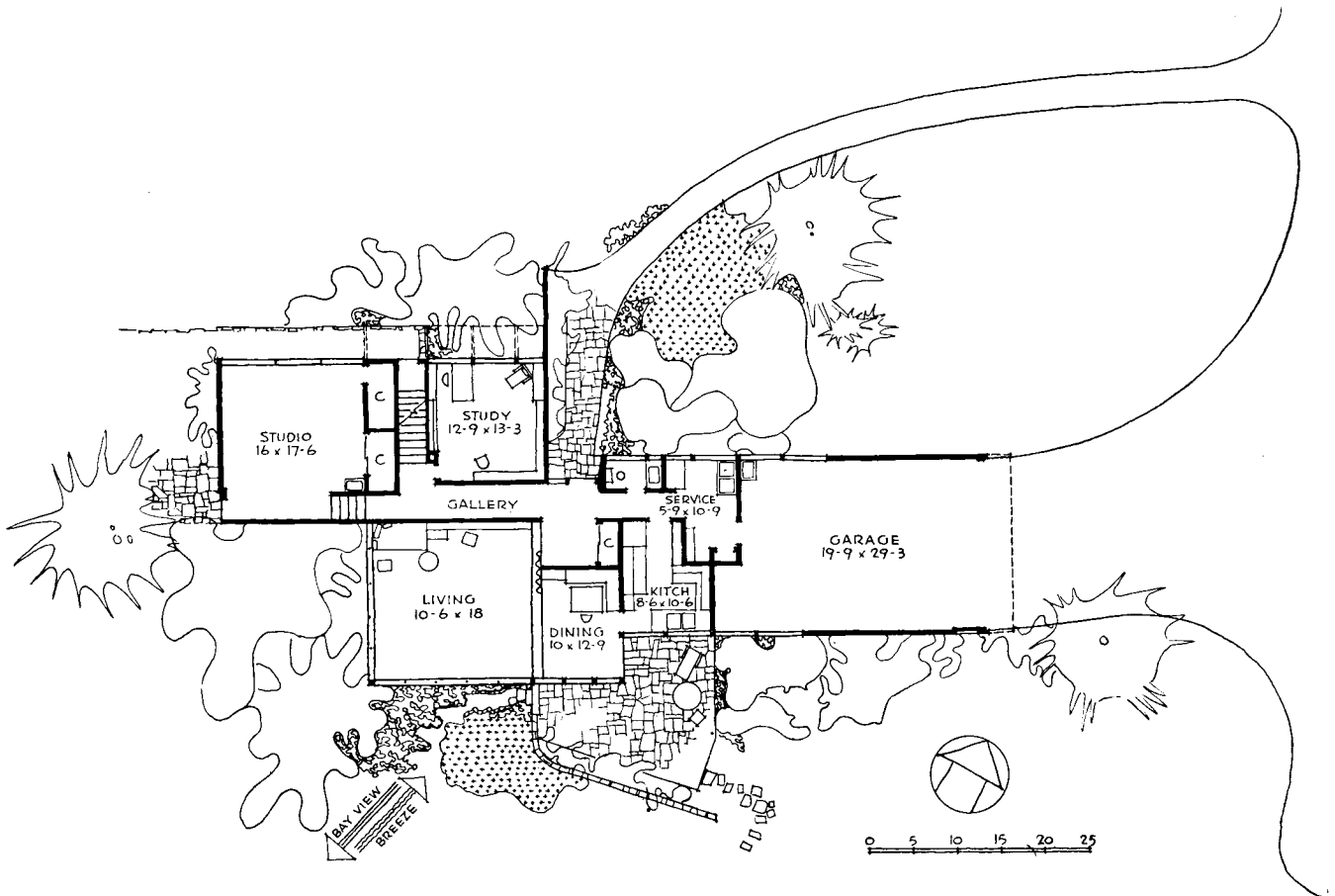



STRAIGHT LINES OR

HOUSE FOR DR. AND MRS. IRVING I. COWAN

Fox Point, Milwaukee, Wisconsin

George Fred Keck, William Keck, Architects

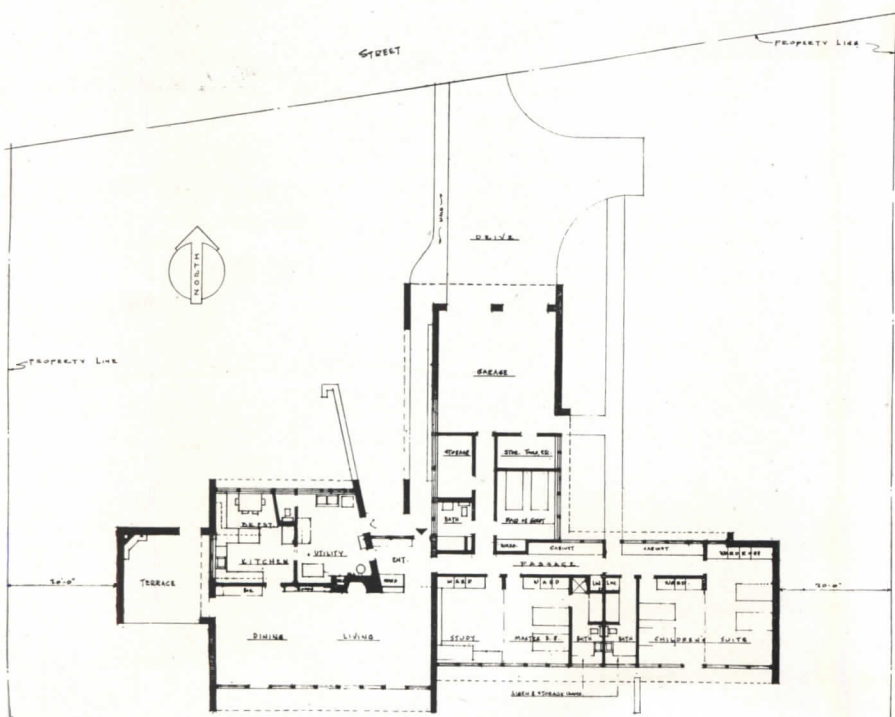

NOBODY would need to be told the name of the architect for this house. You have seen these straight lines, these solar arrangements, these straightforward solutions frequently from the Keck boards. But never one more logical in plan dispositions. The children's suite is easily the feature here, and this is a feature with a future. For the early years it is a huge playroom or a pair of bedrooms at will. In the future it can become a separate apartment for a possible family off-shoot or in-law unit. A kitchenette installation in one of the wardrobe spaces would easily convert it into a really private apartment. It is worth noting that this wardrobe space could easily be spared. Rarely does a plan show such considerate attention to the storage needs of an active family.

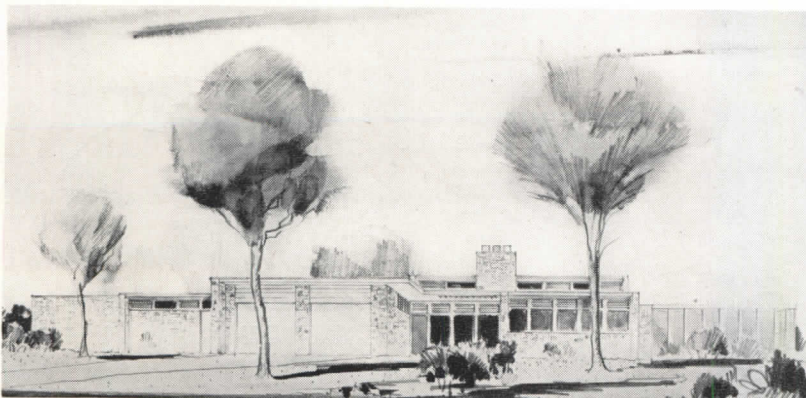



PANORAMIC CURVES

HOUSE FOR MR. AND MRS. JERROLD T. KELLY

Barrington, Illinois

George Fred Keck, William Keck, Architects

WHEN we talked with Keck about this plan we asked him a leading question — how would he describe its functional aspects. "I wouldn't describe it primarily in those terms," he shot back. "I drew it that way because I liked it, and what's more the clients liked it too!" Having got that straight, we could sit back to admire the forthright way he had developed the view toward the "Lake of the Woods," which is just beyond the lower contour line on the plan. All living, family and guest areas enjoy the lake view, with service areas completing a graceful and by no means whimsical curve. The orientation of the curve, by the way, is just as happy for the southwest winter sunshine. The flying screens add a feeling of privacy and functional separation to the façade.

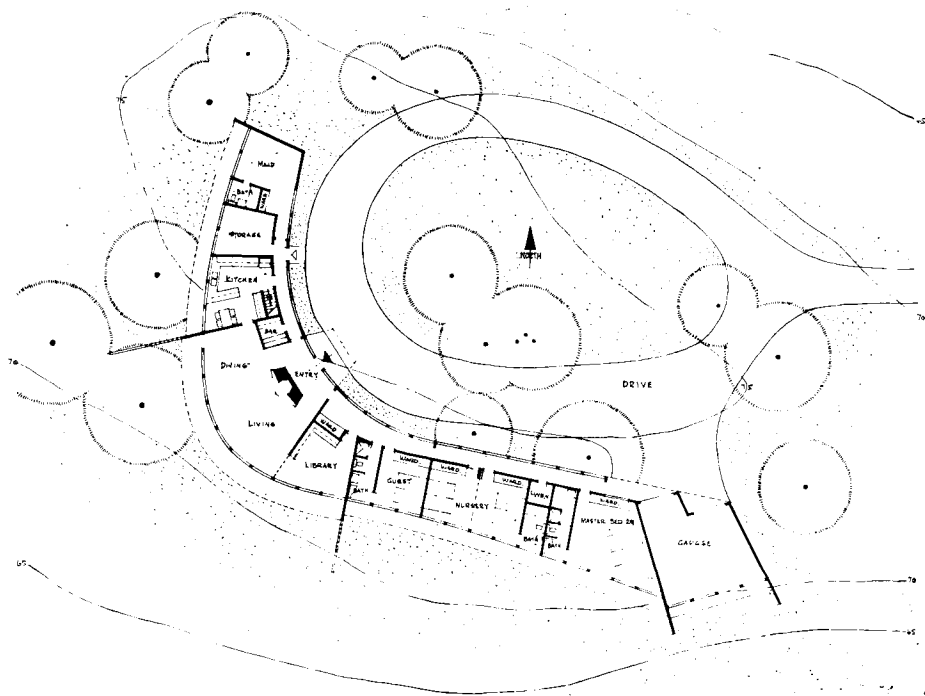

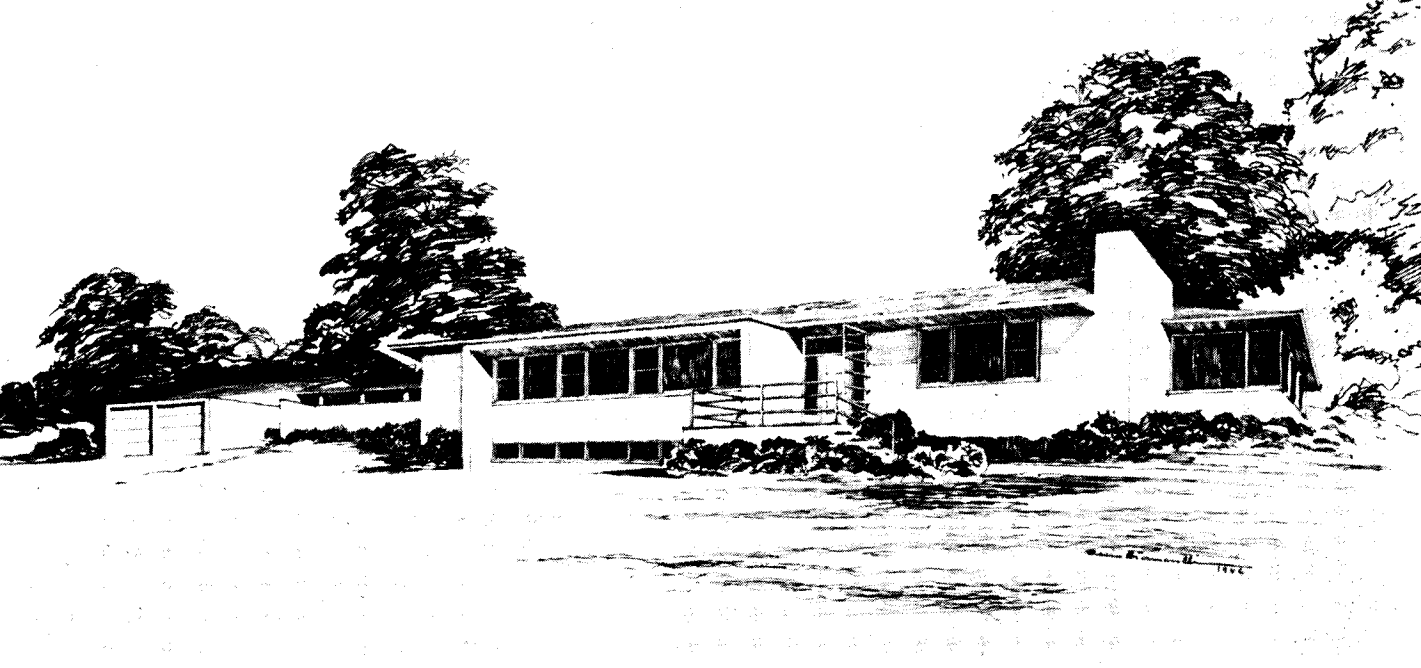

A THREE-PART HOUSE FOR CHATTANOOGA

Gill and Bianculi, Architects

TO MEET requirements of a family comprising the owner, his wife, "a favorite relative, and a son of marrying age," the architects developed this plan which is described as "not tricky, but comfortable and spacious, and appropriate to the owner's stipulations and mode of life." The latter, in turn, declares himself very well pleased with the plans and prospects.

The basement plan, not shown, contains a large recreation room. The architects contemplate either electricity or gas for heating. "The open areas have been made very accessible, and care was taken throughout to insure privacy for various occupancy interests."

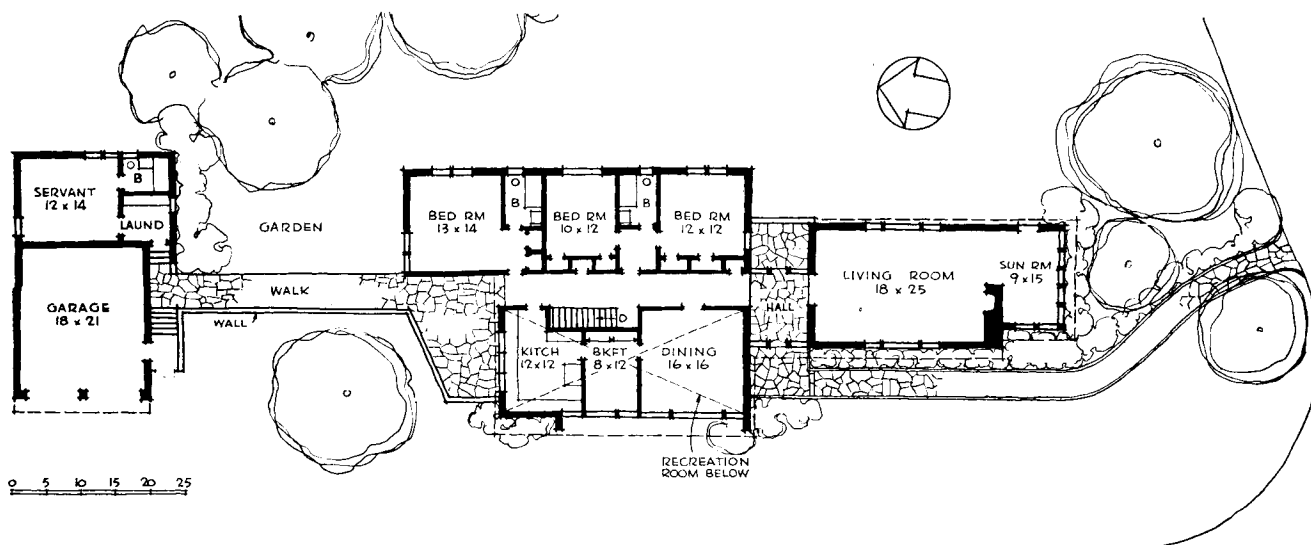
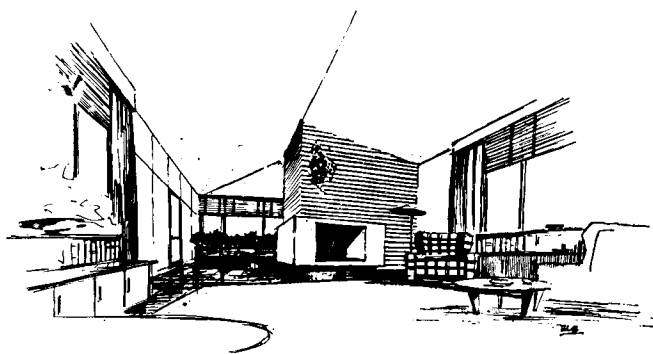

ARCHITECTURAL ENGINEERING

TECHNICAL NEWS AND RESEARCH

ADVANCES IN HOUSE HEATING

By Clifford Strock*

AT A heating conference a few years ago an engineer listed the requirements of the ideal house heating system as one with features which ran somewhat as follows: first cost, very low; fuel cost, exceptionally low; cleanliness, practically 100 per cent; attention required, none; and so on — including a floor-to-ceiling temperature difference of less than one degree. There are combinations of fuels and equipment which will meet some of these specifications; there is, obviously, none which meets them all, and an annoying feature of the whole situation is that the closer one approaches the ideal in physical respects, the higher becomes either first cost or operating cost, or both.

On the other hand, the present outlook is far from discouraging. The predictions of wonders to come in the post-war world have actually materialized in heating to a more than fair extent.

FUELS

There is almost an infinite variety of combinations of fuel-burning or energy-consuming devices, methods of distribution and types of controls available to the house heating designer to the point where the overall subject is difficult to classify for purposes of discussion and appraisal. A logical beginning is with the fuel or energy sources employed, and we will examine this matter first, but return to it later as the occasion arises.

The fuel situation changed sharply during the war and the relative situation among the various fuels is quite different in 1947 than it was in 1940. Coal, due to the increase in price caused largely by higher wages for the miners and to a lesser extent to freight rate rises, is now in a somewhat less advantageous position as a house heating fuel than formerly. It is probable that within the next year or so gas will be more expensive than today, as one after another of the utility companies obtains permis-

sion from public service commissions to advance rates. The picture is even more confused with respect to oil, since there is no general agreement about its future availability and price. An oil shortage has been predicted year after year since the first world war, but has never materialized due to the discovery of new sources. Oil men claim that this is still the case, but some independent experts argue that now there is real cause for alarm. If this is true and we do become an oil importing nation, it would seem inevitable that oil costs would increase, but since there is as yet no conclusive proof of either argument there simply isn't any conclusion to be reached.

COAL

In the meantime two developments seem to hold considerable promise for the future. In Alabama the Bureau of Mines is conducting an experiment in burning coal in the mine so as to produce gas which can be utilized locally or piped to the point of consumption. The Russians previously had done work along this line and apparently with reasonable success. Since there is no argument that

our coal reserves are enormous, and since gas is a clean and efficient fuel to handle, there is much to be gained from this research.

Still more recently the Pittsburgh Consolidation Coal Company announced that a \$120,000,000 project had been started near Pittsburgh in cooperation with Standard Oil to convert coal at the mine into gas and oil by elaborate chemical processes.

The principal traditional advantage of coal as a house heating fuel has been its low price. Its disadvantages have been the dirt involved, including the ashes, and its bulk and space consumption in storage. In many areas coal still enjoys a price advantage and where this is the case and where the income of the home owner is limited, a hand- or stoker-fired installation is still very much in the picture. In addition, a frequently overlooked advantage of coal is the heat available when the fire is banked, which is very often sufficient to reduce what would otherwise be a damp condition in the basement. Modern coal cleaning and treating methods, the high degree of automatic operation of the modern stoker,

Stoker-fed furnace. Automatic firing results not merely in labor savings and greater cleanliness, but also in better utilization of fuel. Coal and air supply are coordinated and adjusted for most efficient combustion under automatic thermostatic control

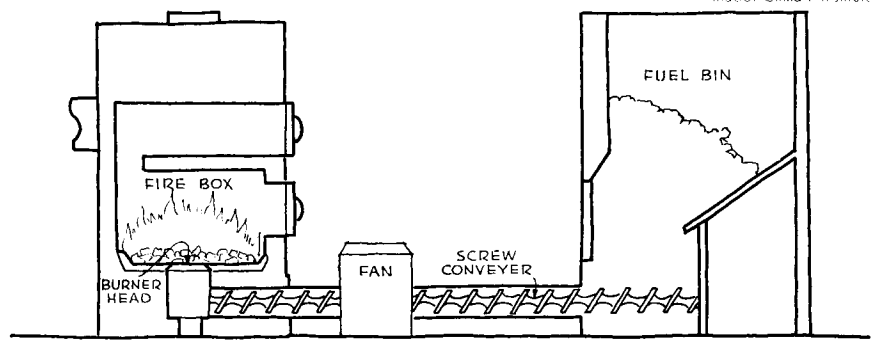

* Editor, Heating and Ventilating.

- A = Combustion Chamber
- B = Spiral Heat Exchanger
- C = To Flue
- D = Warm-Air Outlets
- E = Electric Eye for Flame Safety Control
- F = Motor
- G = Fuel Pump
- H = Blower

Jet-Heat, Inc.

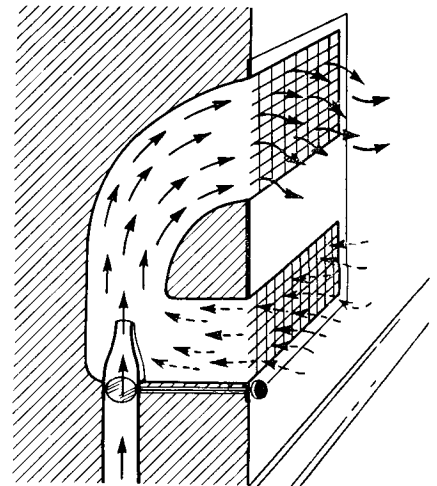
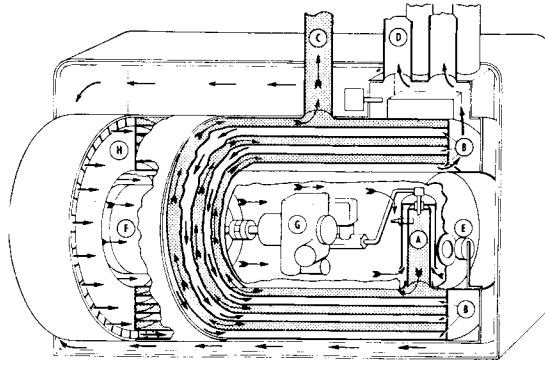

Above. Compact furnace provides warm-air heating for medium-size house by means of high-pressure atomizing oil burner and small flexible tubes to room outlets. Right: Heated air is distributed at high velocity to specially designed registers, into which room air is drawn to reduce velocity and lower incoming air temperature

including the bin-feed feature and ash removal equipment, are such that coal is still the principal house heating fuel.

OIL

The present day oil burner is the result of experience over a period of 25 years and is giving a high degree of satisfaction in several million installations. War-born experience in corollary arts is now being applied further to improve the thermal efficiency of oil burners. Two developments especially are worth noting.

The first is the application of research on jet propulsion to oil-burning problems. The important feature of a device first shown at the recent heating and ventilating show is the burning of oil under high pressure in a 2½- by 5-in. combustion chamber. The fuel is said to be completely burned with a considerable supply of excess air without noise by a properly controlled turbulent mixing of the air and oil. High velocities of the products of combustion in the heat exchanger are claimed to account for high efficiencies and smallness of size of the unit, the efficiencies reported being from 93 to 95 per cent. The complete system has an additional feature not related specifically to the fuel but of great interest, namely the use of small diameter flexible ducts for the distribution of warm air to the rooms at high velocities. Prior to entering the room, room air is induced into the air stream, cooling it from 300° to 150° F., and slowing it from 1500 to 300 ft. per minute. The flexible ducts, of glass fiber and bonded with rubber, should simplify installation.

The second development consists of units designed originally for the heating of airplanes during the war, and which burn gasoline at high efficiency in a small alloy-steel combustion chamber. Such units may have certain important applications in house heating although

it is problematical that the high-cost fuel can be employed competitively with heating oil in spite of a high efficiency. Perhaps more important is the adaptation of the general idea to a gas-burning (manufactured, natural, mixed or bottled) unit of small size — about that of a suitcase — placed at the baseboard and discharging air into the room and intended to heat that room and perhaps also a small adjacent room. Small pipes discharge products of combustion to the outside. Advantages include the absence of piping in the basement.

GAS

Gas more nearly approaches the ideal fuel than either oil or coal in many respects, but it is not without disadvantages. The cost in natural-gas regions is not high, but heavy demands in these regions on cold days have caused some anxious periods this past winter. Manufactured gas, although high in cost, is

not necessarily the highest in overall cost. The lack of moving parts reduces servicing which sometimes annually totals appreciable sums with some fuels. In connection with overall costs, the fuel cost estimate for a given project must take into account all uses of gas. For example, if gas is to be used for cooking, that must be included in the estimate, for the cooking gas will be obtained at a low rate if gas is used for house heating, but at a high rate if not. This, together with consideration of servicing costs, may alter the relative cost setup in favor of gas.

On the other hand, estimates based on present rate schedules may be dangerous. A pertinent question to ask is whether the gas utility has made or contemplates making a rate revision. The heavy demand for gas during the past two years has forced certain utilities to refuse house heating loads from new customers in certain areas. Therefore,

Left: This gas-burning unit is a separate small furnace that can be hidden away in each zone of the house to heat that particular zone, with thermostatic control and modulated flow of heat. Exhaust gases are vented by small pipes to outside the house. Right: Cross-section of heat exchanger and sealed combustion chamber

Stewart-Warner Corp.

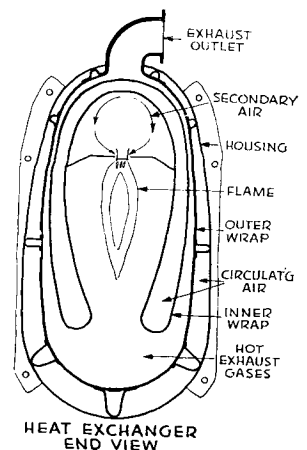
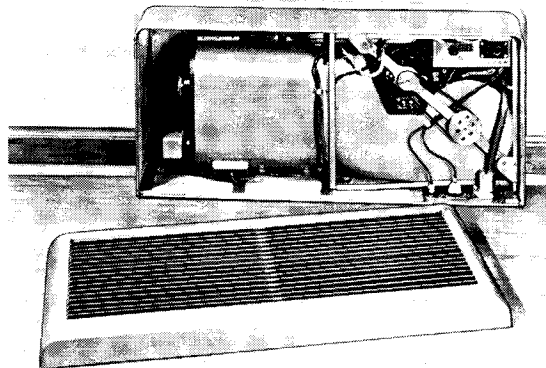

determine whether the project is on an already heavily loaded line and if so what prospects are for additional gas producing facilities.

ELECTRICITY

The ideal source of energy for house heating would be electricity if it were available at reasonable cost. For the vast majority of projects and in most areas it is not yet so available. It is available in certain areas where government-built hydro-electric projects have been developed, such as in the Bonneville region in the Pacific Northwest and in the TVA region in the South. There are two special cases, however, where electric energy for house heating can be considered in other regions: the first is where year round air conditioning is contemplated, the second where off-peak rates are available for thermal storage. To the writer's knowledge, there are no private utility-served areas with such rates, but this is mentioned because of future possibilities. The former is already a reality with the heat pump.

HEAT PUMP

The heat pump was for many years an engineering curiosity. Almost a century ago it was demonstrated that a refrigerating machine could be used as a source of heat, with the heat extracted from the condenser and with the evaporator drawing heat from the air, ground or water at a low temperature. The machine would raise the potential of the heat, or pump it to a higher level—hence its name. To put the matter into more understandable terms, there is heat in the ground even at 15° F. An evaporator placed in the ground thus taps a quantity of heat which is made available at the condenser and since the latter is all that is actually paid for, the heat pump can produce from three to five times as much heat at the condenser as was put into the system in the form of electric energy. This is equivalent to a rate from one fifth to one third that which would occur if the same rate were applied to resistance heating.

A refrigerating machine is a reasonably costly piece of equipment, and even with the aforementioned advantage would not be economical in first cost from a strictly heating standpoint. However, where a refrigerating machine is needed for summer air conditioning then the dual purpose makes year-round use of the machine economically feasible.

Advantages of a heat pump include:

- (1) compactness, since the combination of heating and cooling in one system results in a minimum use of space;
- (2) flexibility of arrangement, since the location of the equipment is not fixed and it can be located on the roof, in the basement or in any part of the house; and
- (3) concentration of utility service by combining heating and cooling require-

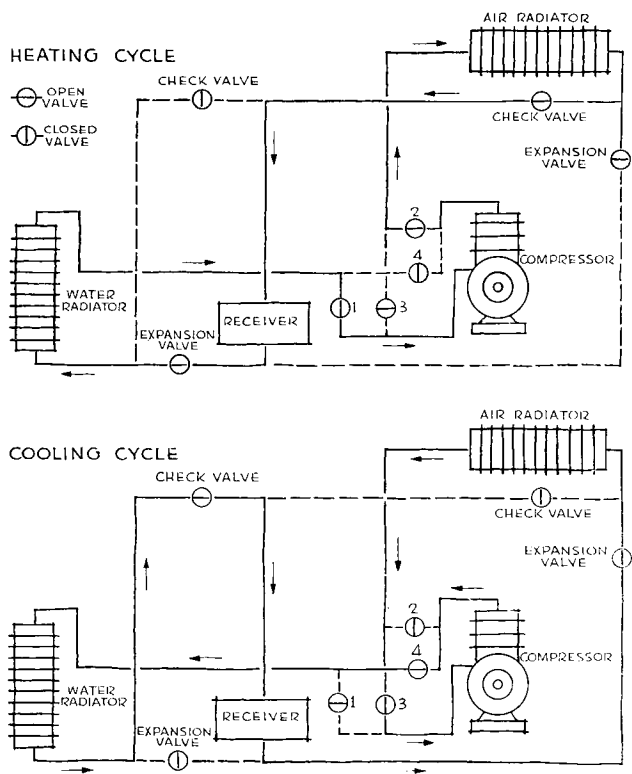

Above: Schematic diagram of one arrangement of water-to-air heat pump with four solenoid valves (positions reversed when season changes). Well water is source of heat.
Below: Comparative costs of various methods of heating, including heat pumps of various coefficients of performance (C.P.); 60 per cent efficiency assumed for oil, coal, and gas.

Chart by E. R. Ambrose

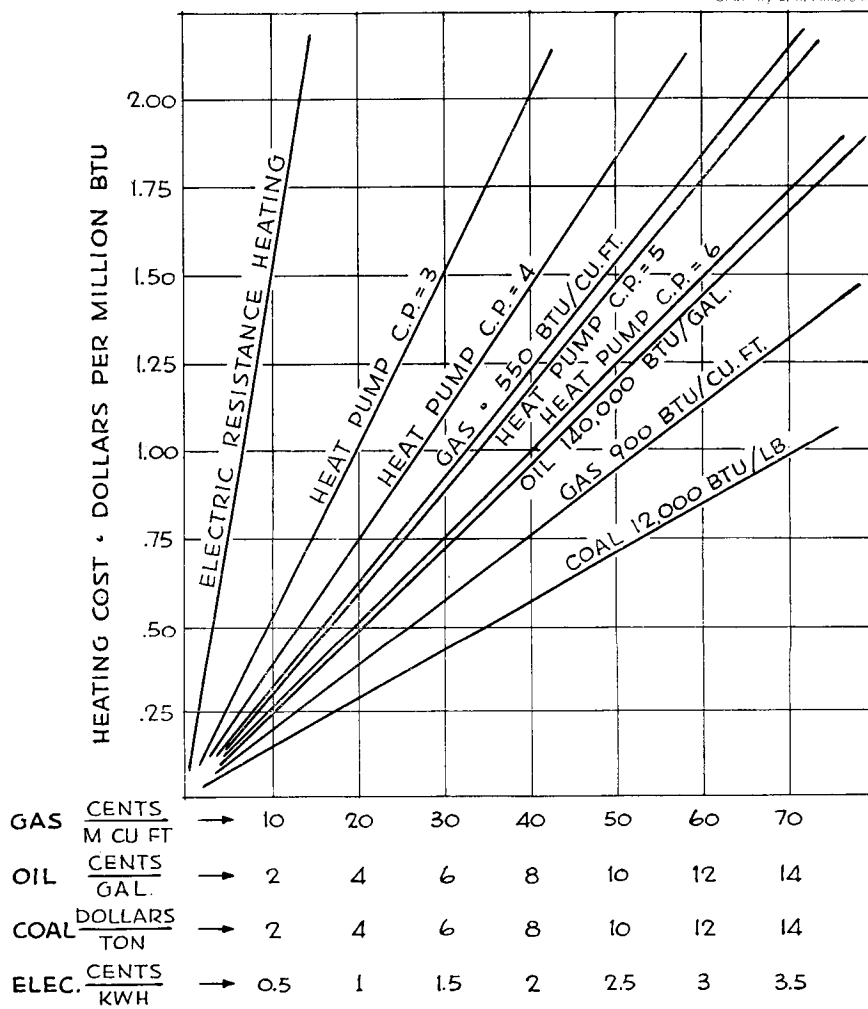

ments into a year-round system arranged to operate on a single electric utility service. Thus the need for any other fuel is eliminated.

The heat pump is past the theory stage and has been actually applied in fair numbers, some as many as 15 years ago. Two manufacturers are in production, and a third expects to be in production by fall. Research is quite active, with several universities and foundations investigating various phases of the matter, including that of the best source of heat and the means of tapping it.

Load factor is always a problem of any public utility, and with any function having a low annual load factor, such as heating, the load is not looked on with too much enthusiasm by the utility company. For this reason, probably more than any other, electric utilities have never done too much about the house heating business. Electrothermal storage does have possibilities in correcting this situation. Most utilities have considerable excess capacity at night, and if the electric energy generated during those hours can be stored for use during the day, the daily load factor of the utility is improved. One method of storing the energy is to heat water in large, highly insulated tanks under pressure. One installation involves pressures of 200 lb. and temperatures of slightly under 400°. During the day, the water is released and the heat in the water at the lower pressure converts the water into steam, which is then passed through a heat exchanger. Many variations of this basic idea are possible, and it is reasonably safe to assume that low off-peak rates will be developed to make this method attractive to home owners.

Electricity has no monopoly, however, on the year-round air conditioning of houses. Where this kind of air conditioning is contemplated the absorption type refrigeration machine has some important advantages. The absorption cycle employs a solvent having affinity for the refrigerant vapor in the absorber. This vessel corresponds to the suction side of the compressor in a mechanical system. The solution of refrigerant and solvent is then pumped to another vessel known as the generator where heat drives the refrigerant vapor out of solution at the higher pressure. This corresponds to the discharge side of a compressor. Thus the energy needed is heat, rather than a motor or turbine. This system is used in the gas refrigerator, and has been applied in a modified form to air conditioning.

Two systems are available. One uses *lithium bromide* as the solvent and water as the refrigerant; the second, *dimethyl ether of tetraethylene glycol* at the solvent and *methylene chloride* as the re-

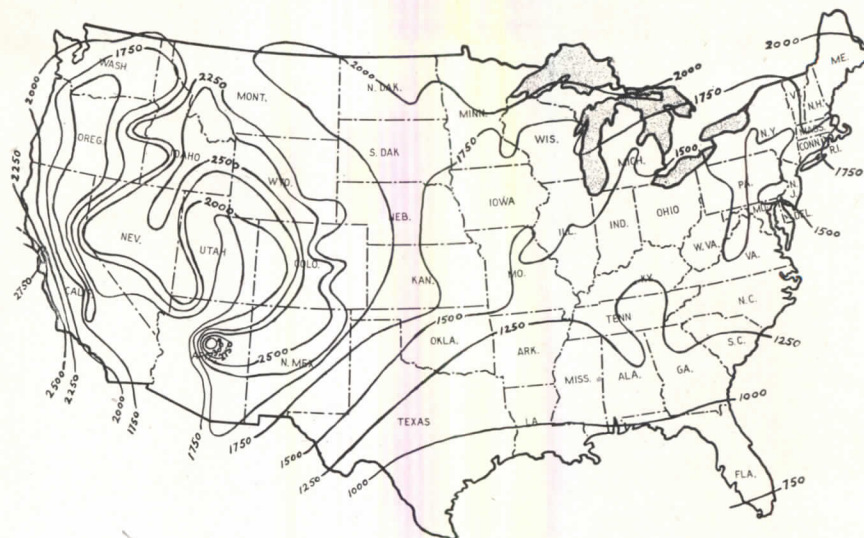

Approximate number of sunny hours during heating season. Dark days in the North are offset by longer season — days when normal mean temperature is 65° F. or below

frigerant. The former is available in gas-burning units, the latter in either oil or gas, but in larger sizes. In both cases a simple heat exchanger is employed for winter heating using the same burner.

Advantages of year-round gas air conditioning are as follows: (1) use of the same prime energy source for both summer and winter seasons; (2) ease of changing from heating to cooling and back again, daily if necessary; (3) quietness of operation and freedom from vibration, features which allow the architect or engineer to locate the equipment in areas otherwise unsuitable; (4) few moving parts, a factor conducive to low maintenance cost and long life; (5) utilization of a dependable, readily available, efficient and clean fuel which lends itself to simple and positive control; (6) in absorption refrigeration units, the possibility of using a safe and inexpensive refrigerant (such as water), conforming to code requirements for air-conditioning

system and operating at a vacuum, thereby minimizing the loss of refrigerant; and (7) efficiencies which afford reasonable operating cost.

Along with these physical advantages, there are economic considerations. For example, the summer air-conditioning load normally occurs during the valley period of gas sendout, but in many cases is directly on the peak of the electric distribution systems. In the first case, there is surplus distribution capacity available, while in the latter, added investment in transmission (and in some cases, generating) facilities is required. This may influence the future relative cost of gas and electric energy for air conditioning services. Yet, even at present, gas equipment may be operated at lower cost in many areas.

In the past many building owners have felt justified in paying a premium for gas as fuel for winter heating on the basis of the stated advantages. Costs fre-

Heat trap developed at University of Colorado. Short waves pass through the clear glass and heat the opaque, re-radiating long waves to which clear glass is not transparent

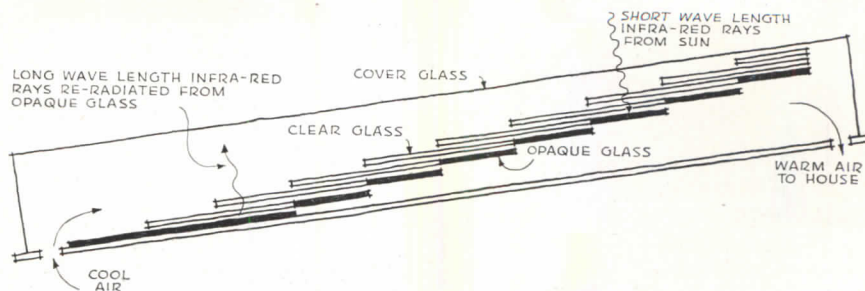

quently were higher than may be expected for the future, because they reflected a good deal of "learning costs" and inexperience in the field as well as expensive hand production at the factory. It is reasonable to believe that, as organized field procedures with trained personnel take the place of inexperience, and mass production replaces handmade methods, substantial reductions in investment costs will be effected.

SOLAR ENERGY

There are a great many ways of utilizing the energy from the sun and most of them have not been explored to any extent at all. During recent years, however, considerable headway has been made along certain lines in determining the results to be expected with certain methods of solar heat utilization, including notable work done at Purdue University, University of Colorado, and Massachusetts Institute of Technology. At the last named institution, an experimental house has a south wall filled with a heat-absorbing liquid in cans. This is a directly opposite type of attack upon the problem from that used in solar houses having wide expanses of glass windows on the south wall shaded from the summer sun by eaves but allowing the sun's rays to enter in the winter. At Purdue, where the latter method is being investigated, two houses, side-by-side and identical except for the ratio of glass to wall area in the south wall, are under test. In the conventional house the ratio is 12 per cent, in the solar house 22½ per cent. The first report of results from these tests showed an average reduction of 9 per cent in degree hours (and consequently 9 per cent in fuel consumption) recorded for the solar as compared with the conventional house.

Still another approach is being made at the University of Colorado, where a heat trap was built on the south roof of

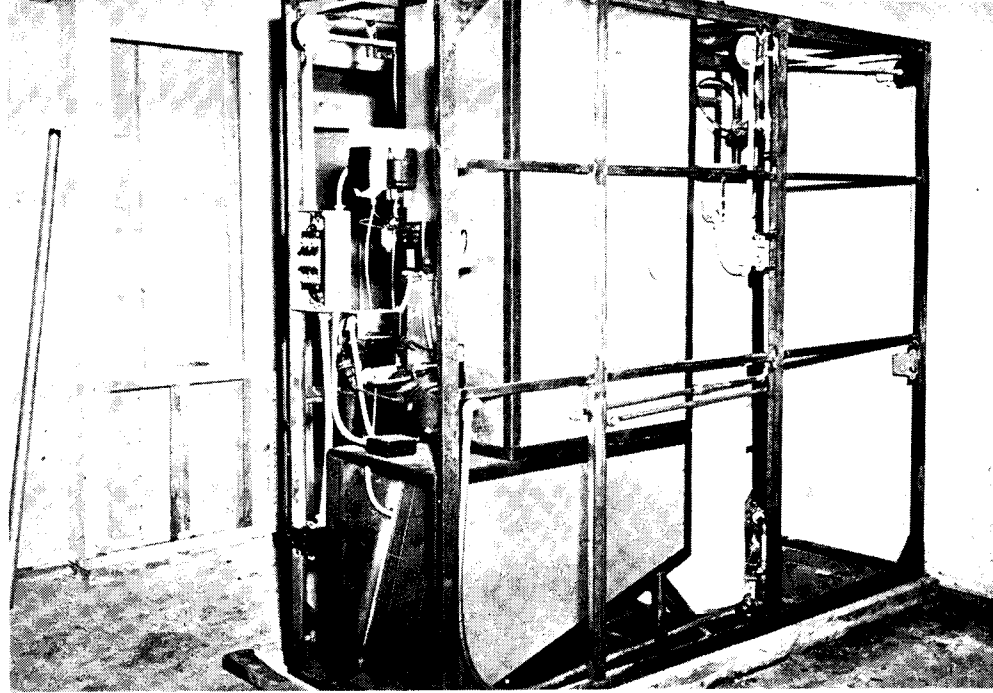

Ingersoll Steel Div., Borg-Warner Corp.

Furnace end of utility core which combines facilities for heating and plumbing

a house. The sun's rays shine on the trap made of window glass which is transparent to short infra-red rays coming from the sun. After passing through the glass, the energy is absorbed by surfaces below which become warmed and emit radiant energy but of a long wave length to which the glass is not transparent. The glass absorbs the energy, becomes warmed, and heats air passed over it, which then is used to heat the building. The air is heated to as much as 200° F. and has actually heated the house to 70° F. in sub-zero weather. A conventional heating system must be used when the sun does not shine, but fuel savings of up to 20 per cent are reported.

As for any problems encountered as a result of snow, it was found that the angle at which the trap was placed would cause the snow to slide off. Hail constituted a different problem, however,

which was overcome by placing a screen over the entire trap. A means of preventing the breakage of glass due to expansion from the heat is being studied.

At the present time, therefore, solar energy can be utilized, not with the idea of replacing the heating system but only as an auxiliary source and a means of reducing fuel consumption.

The accompanying map shows an approximation of the number of hours during which the sun shines during the heating season. The lack of sun during extreme winter days in the north is balanced by the longer length of heating season in that region as compared with the south.

The method of storing electric energy previously described, by which water under pressure is used to store the heat, has an especially interesting feature in connection with the high temperatures

One method of controlling hot-water radiant heating system. Depending upon weather, mixing valve blends return water and hot water from boiler. Mixing valve is adjusted by hand or thermostat

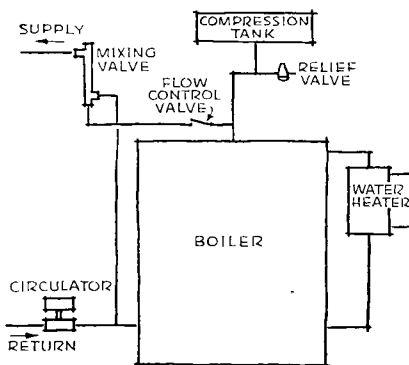

Electric panel heating by means of special heating cable, secured by insulated staples and ready for plastering. About 300 houses in the Seattle area are so heated

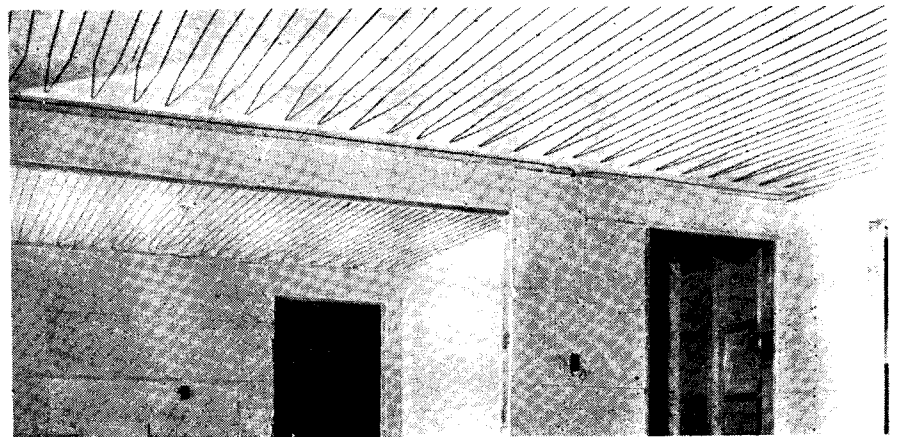

I. N. Roberson Co.

(nearly 400° F.) employed. With such temperatures, the water on flashing to steam could be used to supply pressure cookers and possibly even to operate an absorption refrigeration cycle. The disadvantage is that water at this temperature is at high pressure — a disadvantage in a house from a safety standpoint.

This disadvantage could be overcome by units proposed but not yet available. One would use Dowtherm (instead of water) which has a boiling point of around 500° F. at atmospheric pressures. A single unit would contain heating, hot water, and cooking facilities for a house. Another development, using a patented compound with a boiling point of around 800° F., would fill the same functions and perhaps even that of power generation in isolated houses. Such a fluid could also operate summer cooling and refrigeration.

The single unit idea for mechanical equipment has taken another form in a so-called utility core first announced commercially a year ago. It consists of a prefabricated arrangement which combines space heating and water heating, plumbing, refrigeration, kitchen and bathroom facilities. The heating unit is a steel furnace with gas or oil burner.

RADIANT PANEL HEATING

Perhaps the most discussed subject today in the whole field of heating is radiant or panel heating, in which wall, floor or ceiling surfaces are heated to relatively low temperatures and thus themselves become "radiators" in the true sense of the word. While even before the war there were several thousand of such installations in England and Europe, the first installation of importance in this country in 1930 was followed by only a few others until the late 1930's. Off to a slow start, this method almost overnight became immensely popular and captured the fancy of the layman perhaps as no other method has done.

The most widely employed medium in panel heating is hot water. More recently warm air has gained ground, and in the Northwest electric cable is being used in the walls, floor or ceiling simply

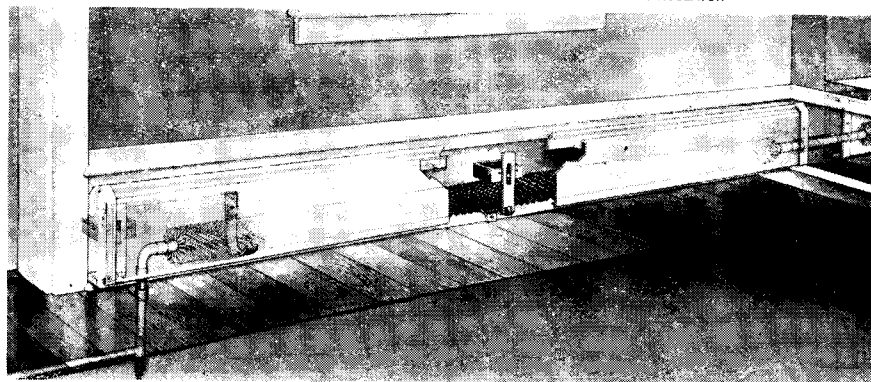
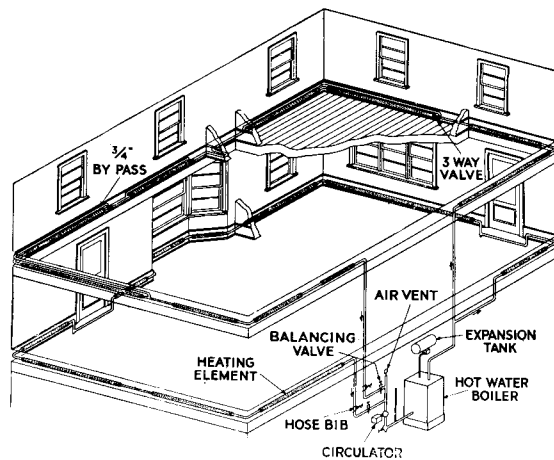
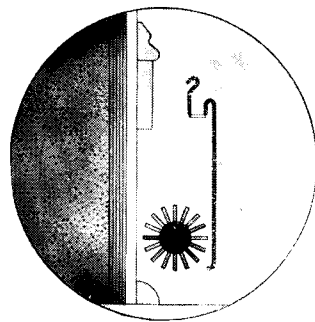

Warren Webster & Co.

In this system of baseboard heating, the heating elements are installed in continuous loops, one to each floor of the house. Where reduced heat may be desired, hot water can be diverted around the heating element by a hand valve. Heating element is 3/4-in. copper tubing with 2 1/4-in. diam. fins. Air enters at floor line, passes over convector element and out the top. Floor-to-ceiling temperatures vary less than 2° F.

being plastered in or otherwise covered. A cable commercially on the market for this purpose has a maximum continuous temperature of 167° F., installation being made on a basis of 1 1/2 watts capacity per cu. ft. of space in large rooms and 2 watts per cu. ft. in small rooms. The desirability of using this method is, of course, closely related to the cost of electric energy. Experiments are also being made using thin aluminum foil strips on ceilings.

At the present time most floor installations seem to be of ferrous pipe while copper tubing is used in most ceiling

jobs. Either is satisfactory for floor or ceiling installation and either a floor or ceiling installation will give satisfaction where properly designed and installed.

With warm air, a dropped plaster ceiling which acts as the radiating surface (about 2 1/2 in.) provides space in which warm air circulates. Somewhat more energy is required for the fan than for a corresponding pump with a hot water system, but this is offset by the argument that a leak in the warm air space would be no consequence.

Just what are the advantages which radiant heating offers and which have

Two types of hollow cast-iron radiant baseboards. Left: Front and rear views of standard baseboard with a rating of 1.25 sq. ft. per linear ft. Right: Similar views of a higher capacity type with extended surface and a rating of 2.08 sq. ft. per linear ft.

Burnham Boiler Corp.

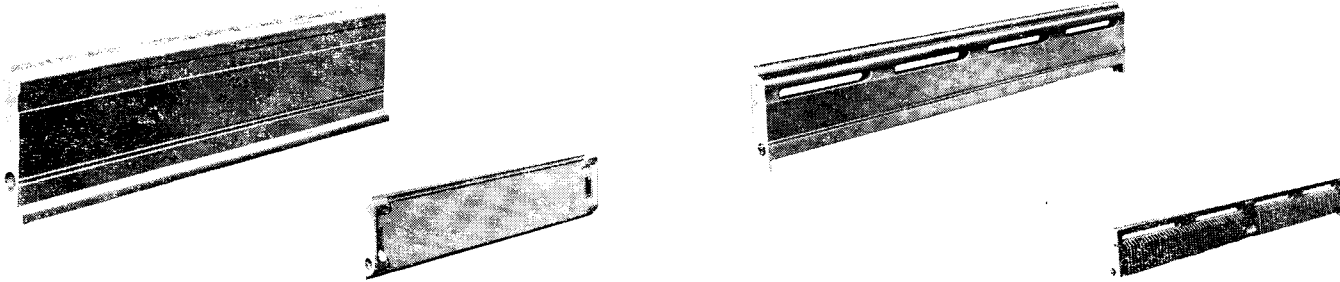

caused so much interest in it? The first and indisputable one is that there is no visible heating equipment to mar the decorative scheme or occupy floor space. From that point on, the advantages of radiant as compared with convection heating become more and more a matter of opinion. Proponents of panel heating claim substantial fuel savings, but this is always a difficult point to establish. They point to a feeling of greater comfort, but since comfort is subjective, it is hard to prove. The cost is a little easier to determine and so far, in most cases, panel heating is somewhat more expensive to install than a corresponding convector job. It is possible that this is a temporary situation due to the unfamiliarity of contractors with this work.

The preceding summary appears to be a very inconclusive argument for radiant heating; in many respects this is due to the nature of heating. In heating there are so many variables that even years of research may not yield a conclusive positive yes-or-no answer to a given question. For example, can anyone prove that, by engineering evidence, warm air is preferable to hot water for house heating — or vice-versa? The writer believes not; so much personal opinion and personal experience enter into such questions. Not only these factors, but also specific requirements, such as location, architects' and owners' preferences, and climatic conditions, are variables.

However, the fact that proof for some of the claims for radiant heating can't be completely established doesn't mean that these advantages do not exist. This method of heating has been developed to a reasonably high degree. There is much to be said for it. There is also much to be said for convection heating (whether with convectors, radiators or circulating warm air). As a result the writer concludes that as time goes on it will be found that each method has its own particular field of application and all will be widely used.

Baseboard heating is one of the new variants of radiant heating. There are two distinctly different forms of baseboard heaters available, one being a more or less flat cast iron chamber which replaces the conventional baseboard and through which hot water is circulated. The other is a combination radiator and convector; in one make it consists of a copper tube with copper fins running in a continuous loop around the exposed walls of a house, a separate loop for each floor, and concealed by a metal baseboard. Space at the bottom and at a molding in the top permits air to flow through and become heated by convection. Radiation is from the front of the baseboard. Another design is of cast iron with vertical fins.

Results obtained with these units indicate an exceptionally low floor to ceil-

ing temperature differential, and, as with the radiant heating, the absence of visible heating equipment is an esthetic advantage. Additional advantages include the accessibility and simplification of piping, since usually only one riser and one return are ordinarily required for each floor. In the case of the convector type, the baseboard can be removed for cleaning, although this is required only once a year or so, since the low air velocities do not carry dirt over the heating element in quantity. In rooms of exceptionally high heat loss, due to high ceilings, severe exposures, poor construction or extreme climate, the baseboard may not give the necessary capacity. Conservative manufacturers prefer to consider baseboard heaters as a specialty and be consulted on each installation so as to be assured that heating satisfaction results.

In house heating today, steam or vapor enters the picture whenever the project becomes large enough so that the power requirements of a fan or pump become a consideration. One experienced engineer sets the dividing line at about 1000 sq. ft. of radiator surface. Above this point steam should be included for consideration, below it steam is probably noncompetitive.

Gravity hot water is today practically dropped from consideration. There is considerable design detail involved in a good gravity system and few designers are interested in making the lengthy and unprofitable calculations involved in a residential project. Forced hot water systems are simple to design and have additional advantages which make it well worth while. Use of a circulator overcomes the sluggishness of a gravity hot water system and thus prevents overshooting of temperature, with the

result that it saves fuel. The power requirements are small.

So far not much attention has been paid to the more conventional equipment and systems; instead the emphasis has been on the new and more or less exciting developments. The architect has been through the mill with the older methods and systems and knows them, as he knows old friends, with an understanding of their good points and their weaknesses. The convector is an example: it is now approximately 20 years old, has proved itself, and the proof of its acceptance is reflected in the gains it has made on the cast iron direct radiator. When recessed or concealed it is not entirely invisible, but in a great many cases is practically unnoticeable.

TEMPERATURE CONTROLS

Control of hot water — or steam — has reached a high stage of development. One well known method is to use a mix-

Oil or gas floor furnaces in packaged units can be installed beneath floors inexpensively and simply, without ducts

Colman Co., Inc.

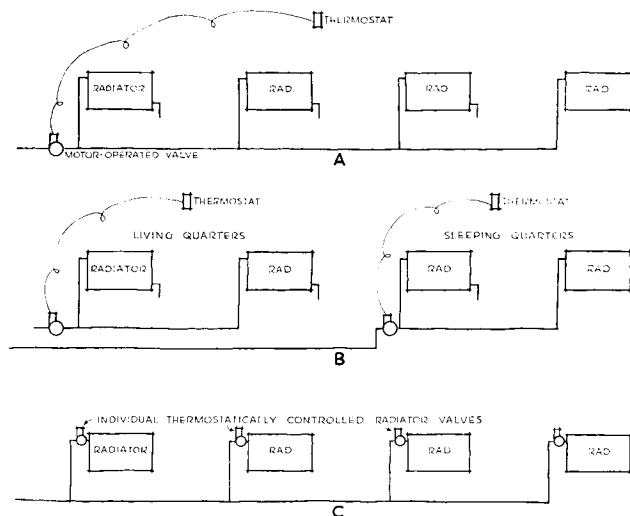
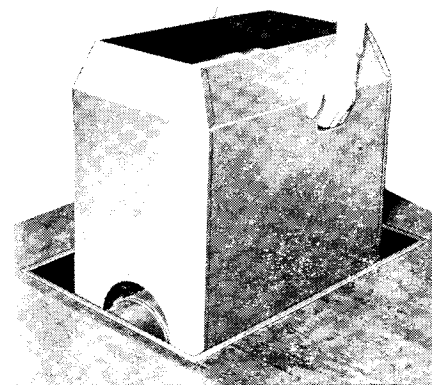

Various applications of motor-operated control valves to water or steam systems: (A) all units controlled by single thermostat (steam or water at boiler controlled by limit switch operating the burner); (B) house divided into zones determined by room exposures or occupancy requirements; and (C) radiators individually controlled. For warm-air systems, motor-operated dampers can be similarly applied

ing valve in which hot water from the boiler is blended with cooler water from the return line and with the ratio automatically adjusted by a thermostat located outdoors, so that the lower the outside temperature the higher the ratio of hot water to the total handled by the circulator.

There is considerably more awareness today of the desirability of varying heating output or distribution to occupancy requirements. A busy housewife in the kitchen, with a stove in operation, has a sharply different demand for heating than she does a few hours later in her living room, and both of these rooms have occupancy requirements different from the bedrooms. To add to the confusion, the rooms on the north on a sunny day have greatly different demand from those on the south.

One approach to such a problem is to have individual thermostatically-controlled valves on every radiator. More frequently, however, the building is zoned, making a separate zone of each portion of the house with similar heating requirements. The hot water or steam main to each zone is then valved, with a thermostat in each controlling the operation of the valve serving that zone. The valve can be one which is either totally open or totally closed, or of the modulating type, the opening being in proportion to the heat demand.

The mixing, or three-way valve principle, can also be applied to the warm air system, in which case interconnected dampers mix return and heated air. Similarly, the zoning idea is also applicable to warm air, with open-and-shut or modulating dampers operated by a motor serving each zone.

AIR CLEANING

One of the important advancements in heating systems in recent years is that of the electrostatic air cleaner, now available for use with warm air furnaces. Appreciation of this device will be greatest, probably, in soft coal burning regions where curtains and draperies need recleaning every few weeks. Removal of dirt from the air on each passage through the heating system enormously reduces the soiling effect. These devices, naturally are still comparatively expensive. In many communities where the air is not especially dirty the conventional replaceable filter will do an adequate job.

Just as gravity hot water systems have more and more dropped out of sight, so has the gravity warm air system declined somewhat in popularity in larger houses. The warm air system operated by gravity does not have the inertia of a hot water system without a pump, but it has its own peculiar disad-

vantage, that of its inability to supply the warm air to the windward side of the house in too many cases.

One additional accessory to the warm air system is an ultra-violet air sterilizer. This device is currently being tested in a number of school rooms, and its eventual application in houses seems only a question of time.

Throughout this article an attempt has been made to evaluate or appraise the possibilities of some of the newer developments in house heating. Some of these comments have been qualified, some not. At any rate it should be emphasized that there seem to be very few cases where an unqualified flat statement can be made about the advantages, disadvantages, strength or weaknesses of any combination of fuel and system. The reason for this is that so much depends on the circumstances, objectives, client's income and so on. For example, it is possible to heat a small house comfortably with a warm air furnace with only one outlet and with no fan. The result may be some overheating in certain areas, perhaps underheating in others, and there would almost certainly be a high temperature differential between floor and ceiling. In spite of all these facts, such an installation is desirable for a certain type of small house where economy in first cost is an extremely important consideration. If the climate is mild, then the number of possible applications of such units might be greatly increased.

Similarly, smokeless coal-burning space heaters have recently made their appearance, and can be expected to be used in large numbers, for they fill a real need in the small house field.

The point is, then, that appraisal and evaluation require a basis of comparison and there isn't any single basis of comparison to use.

The list which follows is a partial check list of some of the more important points to be considered in appraising heating systems. These points are not necessarily in the order of their importance, although some of the items of lesser importance are placed toward the end.

1. Cost of installation, ready to operate, and operating cost, including not only fuel or energy costs but maintenance, servicing and repair.

2. Reliability of manufacturer and installer. Both should be financially responsible and with a good reputation.

3. Capacity of unit or system. Will proposed arrangement meet 70° F. requirement on coldest day? This includes not only the unit or system itself but ability of the source of fuel or energy to deliver under extreme conditions.

4. Dependability of the unit or system. This is exceptionally important, and includes investigating evidence from other users if method is new.

5. Degree of automatic operation and control.

6. Floor-to-ceiling temperature differential. This affects economy of operation but also comfort; a 70° F. temperature at the breathing line may meet the contract but if the floor is at 60° F. the owner will be less than happy.

7. Horizontal temperature difference. Is the desired temperature maintained throughout? It may be 70° F. at the living room breathing line and 65° F. at the dining room breathing line.

8. Occupancy requirements. Design should meet as far as possible the requirements of the family and of the type of room.

9. Space occupied by the heating system, including fuel and ash storage facilities, if any, in basement and the various rooms.

10. Cleanliness, including odors.

11. Noise. Consider possibility of transmission to rooms.

12. Harmony with decorative scheme.

The architect and his clients today have available for their selection the most comprehensive and versatile equipments for heating ever known. The only fly in the ointment is that the very completeness of these lines creates confusion and may result in bewilderment when the final decision is to be reached. This is a low price to pay, however, for the richness of the array.

Electrostatic air cleaner is designed to remove 85 to 90 per cent of airborne dust particles, when connected with warm-air furnace or as part of an air-conditioning or air-circulating system

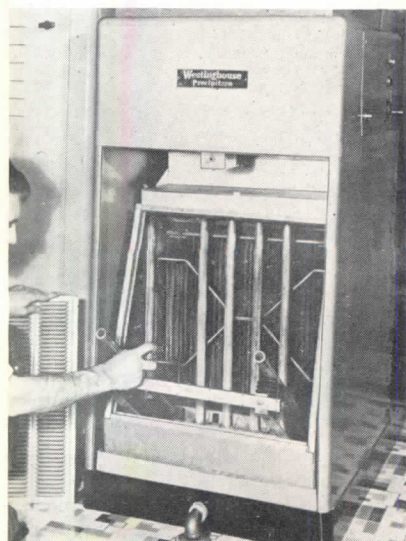

Westinghouse

THE SCHINDLER FRAME

R. M. Schindler

Architect



PROBLEM

Material and construction are an integral part of the conception of a building.

The standard system of wood frame construction is not suitable for the execution of the contemporary dwelling. The balloon frame presupposes a box-shaped building and cubicle rooms, with large wall areas and small openings, solid partitions, a superimposed sloping roof with small projection of decorative character only.

The space architect thinks in terms of articulated space forms. Large openings

reduce walls to a minimum. Ceiling heights vary without disturbing the rambling low-to-the-ground and open-to-the-sky character of the building. Careful orientation of rooms makes clearstory windows and large shady overhangs mandatory.

SOLUTION

My struggles with tradition-bound carpenters finally developed the "Schindler Frame," which eliminates a multitude of structural makeshift details which the balloon frame forces on the contemporary building. In building a contemporary house, the "Schindler Frame"

utilizes ordinary framing lumber and established framing techniques. Although some of the features shown are based on California building regulations and conditions, only slight alteration should be necessary for use in other climates.

FLOOR FRAMING

Basements, with all their expensive problems of moisture, drainage, ventilation, light supply, sanitation, and access stairs, are eliminated. Consequently the desired more intimate connection with the out-of-doors may bring the floor of the house close to the ground.

The standard floor construction, built

Julius Schuiman Photo

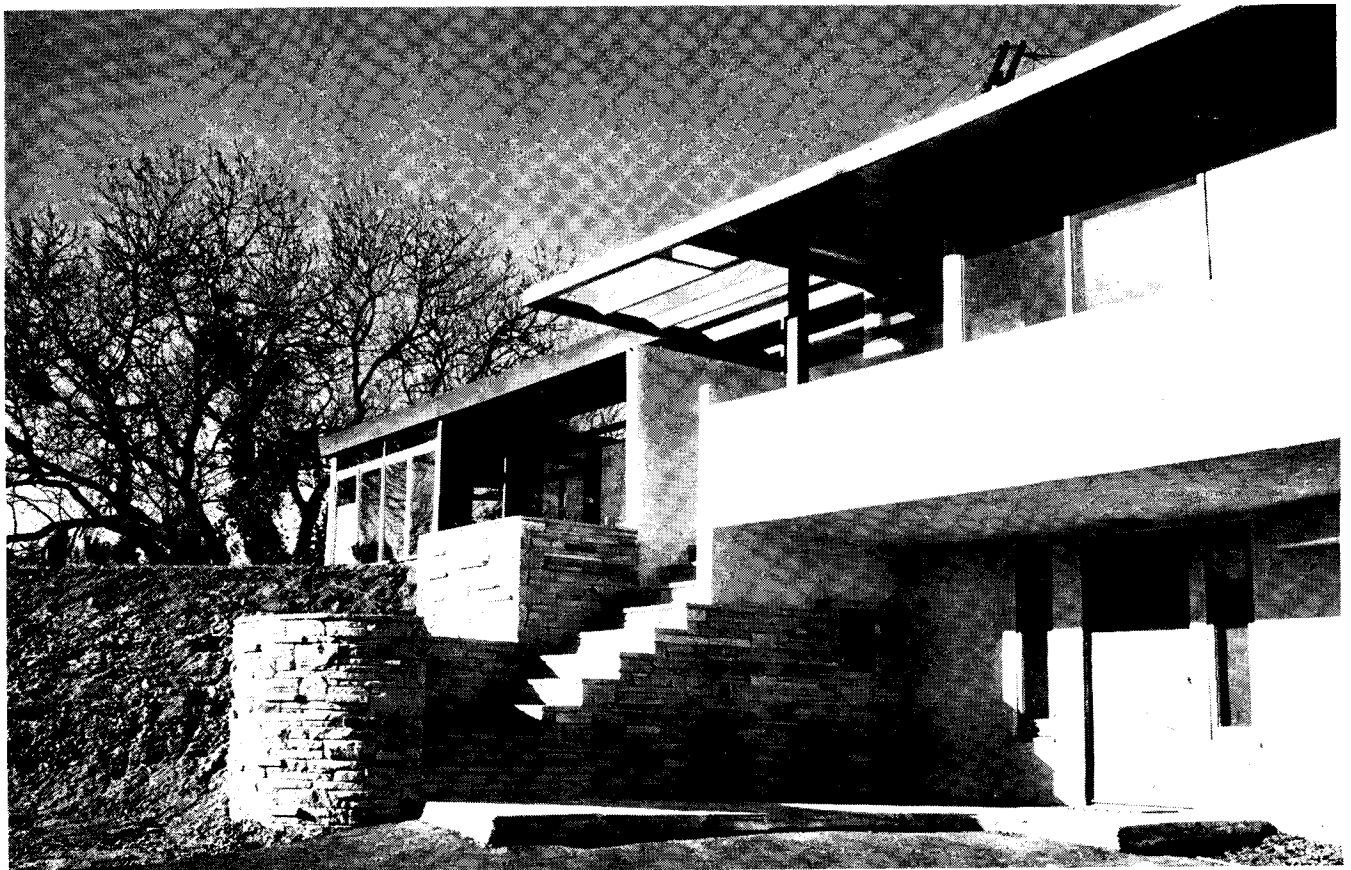

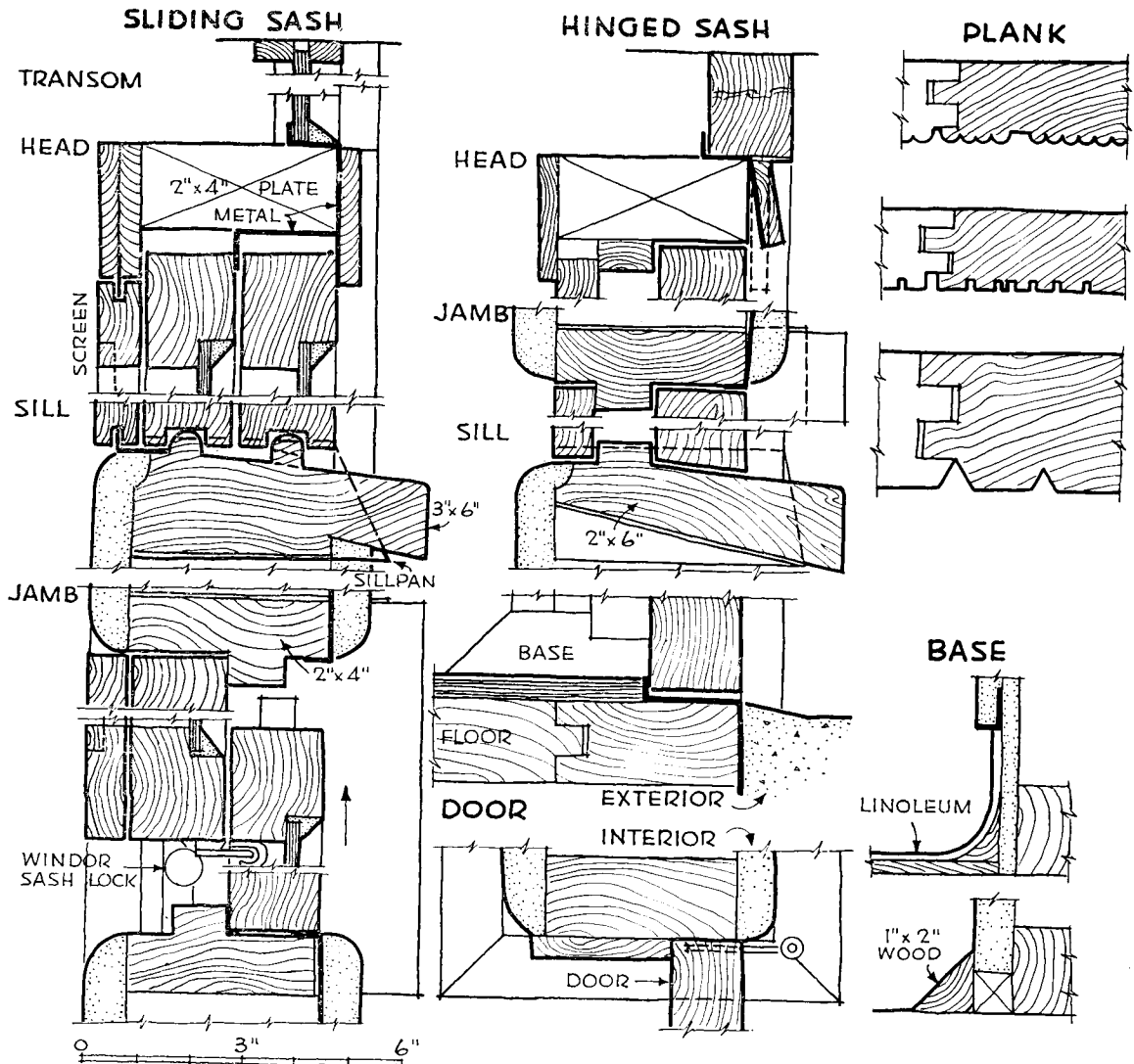
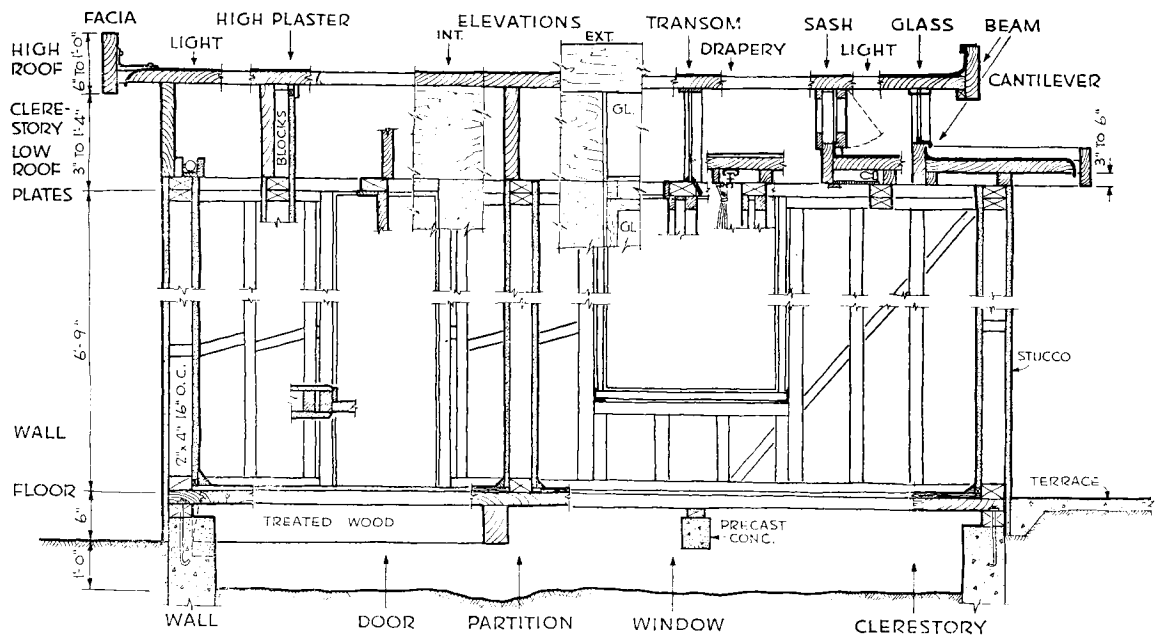

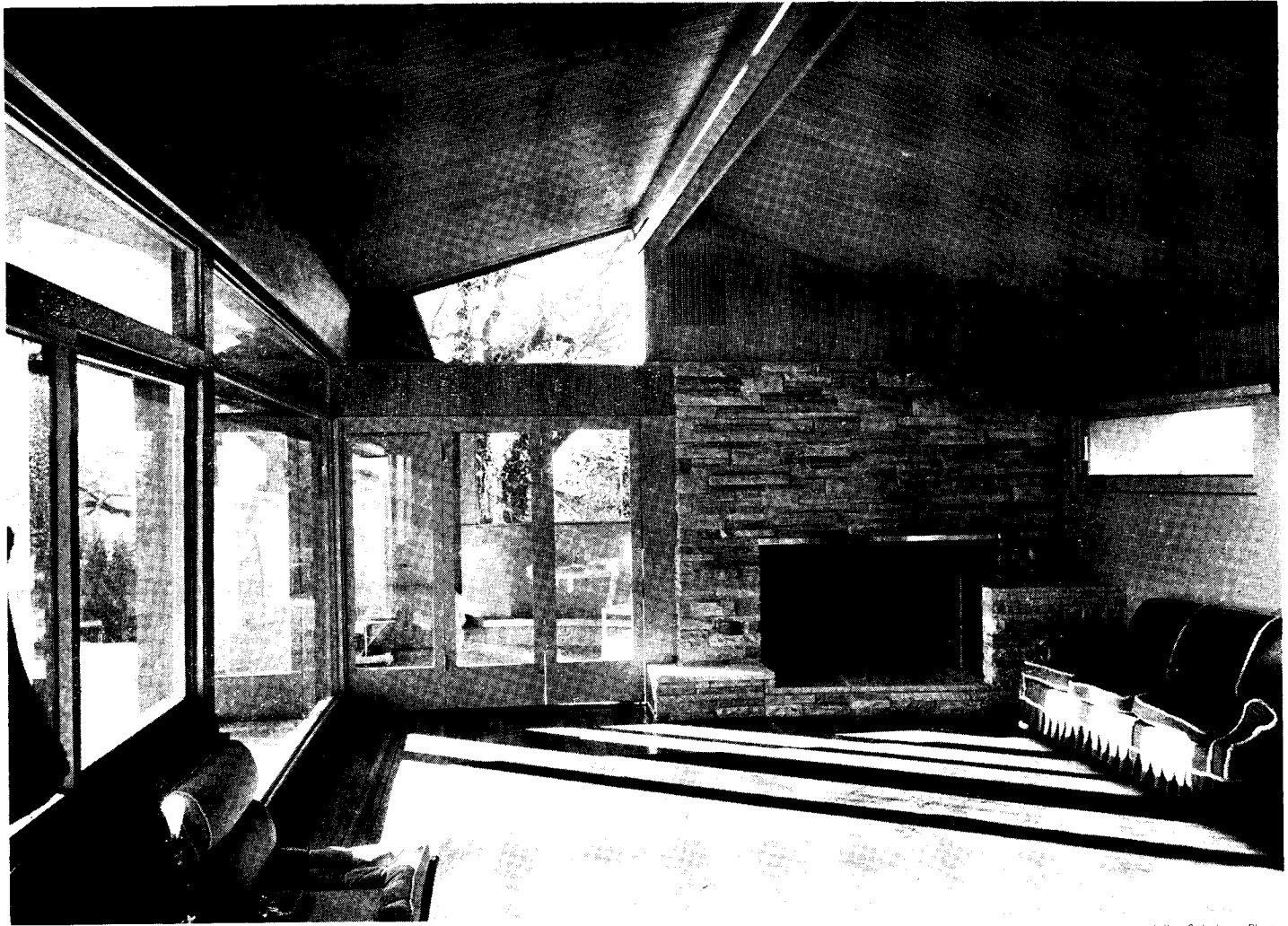

Julius Schuman Photo

up of beams and joists, requires expensive treated lumber, and, because of its thickness, deep excavations. The proposed tongued and grooved planking of the "Schindler Frame" is simpler to install, reduces treated lumber to a minimum, and gives a warmer floor. Carpeting may be applied without any additional finish flooring. The possible wide floor spans make the use of termite-proof prefabricated concrete beams economical for house construction.

WALL FRAMING

The traditional stud is cut to wall height and provides for a double plate at ceiling. In a space house, ceiling heights vary repeatedly. This makes it difficult for the carpenter to ascertain and locate the various stud lengths required. It also interrupts the top plates wherever ceiling heights change, thereby weakening the important horizontal tie these plates should provide for the building.

The "Schindler Frame" eliminates all these difficulties by cutting *all studs*

throughout the house to door height, and thus provides a *continuous* belt of plates at this height. The horizontal continuity of the design becomes a structural reality and does not have to be attained by a repetition of abstract measurements.

DOORS AND WINDOWS

Door and window frames are set in below and above these wall plates, which give a horizontal guide for their heights.

The standard double-hung or casement window is not suitable nor structurally feasible for the large unbroken openings to be provided. Therefore, wide openings are equipped with sliding sashes, which remain evenly supported whether open or closed. Their size is limited only by their inertia, which, if excessive, would make operation difficult. No complicated wall pockets to hide them are contemplated, since the wall areas are seldom large enough to receive them. In case of windows which extend above the height of the main plate, it is usually sufficient to operate

the section below it, and the portion above may become a simple stationary transom. Narrow hinged sash and exterior doors always open out. This feels better, is more sanitary, saves room space, and avoids complication with drapes. Flyscreens are preferably inside, protected against the dirt and weather.

Space architecture has to give special consideration to windowheads, which may interfere with the continuity between two adjoining space units. The ideal condition would be to carry the adjoining ceilings through without any header to emphasize the separating wall. The elimination of such headers becomes a very complicated problem in the standard frame. The "Schindler Frame" simply cuts out the bottom plate and uses the remaining plate as the head member of the frame for both doors and windows. This member thereby becomes small and unobtrusive, and does not interrupt the continuity between adjoining space units, especially between the room and the out-of-doors.



CLEARSTORY COURSE

On top of the plate course rests a horizontal band consisting of timbers and glass, which raises the ceiling to the required height. These timbers are generally from 3 to 16 in. high, and serve at the same time as headers to bridge openings, as roof beams, and cantilevers for overhangs. If higher than 16 in., a built-up truss may be substituted.

Julius Schulman Photos



Clearstory windows are inserted without difficulties, and the roof levels stepped at any place regardless of partitions and walls below, giving the space architect complete freedom to shape the rooms. Overhangs are carried by means of cantilevers which are easily and deeply anchored into the structure.

ROOF CONSTRUCTION

The standard roof construction with rafters, sheathing, ceiling joists, and plaster, is complicated and so thick that clearstory windows between different roof levels necessitate excessive ceiling heights.

The "Schindler Frame" eliminates all rafters in favor of a tongued and grooved plank flooring, which forms roof and ceiling at the same time. Since the composition roof used may spill at all edges, roof slopes may be eliminated completely or reduced to a minimum to help drainage. The composition top sheet should be laid without laps, and a heat-reflecting surface is advisable. The plank may just as easily be used for hip and shed roofs. Its acoustical properties are superior to ordinary plaster and may be further improved by proper detailing.

The efficiency of the plank roof compares favorably with standard constructions. It cuts labor costs without adding material. A thickness of $1\frac{5}{8}$ in. will span 10 ft., which can usually be made the maximum span due to flexibility of

the clearstory course. It eliminates *rafter-cuts* and plaster, since it may be treated to form a finished wooden ceiling, doing away with the usual plaster cracks. Space continuity is maintained, since ceiling and overhangs are of the same material. The plank may be run with various profiles to suppress joints, checks and defects.

As far as insulation is concerned, the 2 in. plank is superior to the usual attic, and its efficiency may be improved by increasing its thickness, which will also strengthen it. This is less expensive than the application of insulating materials (fiberboard, etc.) since these require extra labor for an additional operation. If the planks are $2\frac{5}{8}$ in. or more thick, they are considered to be one-hour fire resistant.

By treating the ceiling and the clearstory course in wood, the wall treatment (plaster, etc.) stops uniformly on the level of the top plates, thereby eliminating scaffolding and emphasizing the screen quality of the wall. The same considerations recommend the use of glass gables in case the roof is sloping.

The roof edge is protected by means of a fascia which also serves as a supporting beam between cantilevers and to span clearstory openings.

It is obvious that, as soon as our technique permits, the tongued and grooved plank may profitably be replaced by a prefabricated cellular slab.

UTILITIES

The elimination of the attic space has no disadvantage as far as utility service is concerned. Distribution is made below the floor. No electric outlets are necessary above plate level, either for direct or indirect lighting. By keeping the direct light sources at door height, near eye level and facing down, they are never seen squarely, thus assuring maximum effect without glare.

The "low roof" serves efficiently to shade the windows, and receives Venetian blind pockets and curtain tracks as an organic part of the structure.

EXECUTION

Anyone who has ever supervised the building of a contemporary house will realize the relief of being able to give the carpenters one uniform stud-length, and to eliminate all notches for cantilevers, ties, and rafters. Although the "Schindler Frame" unavoidably repeats certain characteristic details, it allows such freedom in the use of the more *important features* of space architecture that it should prove a boon in developing it, and might well help to give contemporary houses what the past called "style."

PRODUCTS for Better Building

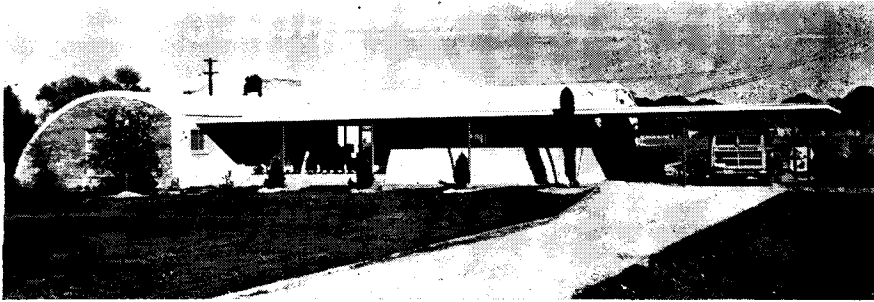

Quonset-type framing units have been developed for low-cost houses, 20 to 24 ft. in width

ARCH-RIB STEEL FRAME

Steel *Arch-Rib Framing Units* for low-cost Quonset-type houses have recently been announced by Stran-Steel. Houses of this type, containing five rooms, reportedly can be built to sell within a \$4000 to \$6000 price range. The framing units, for 20-ft. and 24-ft. wide houses, are individual curved I-shaped members with a flange width of 2 in. and a depth of 3 $\frac{5}{8}$ in., cold formed from 16 gauge steel and joined together so as to provide a nailing groove. Straight Stran-Steel studs are used where vertical side or end walls are desired. Exterior covering consists of shop-curved or straight corrugated steel sheet. Interior finish is of conventional materials applied over wood or steel furring members. Floors and partitions are conventional and site constructed. Stran-Steel Div., Great Lakes Steel Corp., Penobscot Bldg., Detroit, Mich.

SOUND SYSTEMS FOR HOUSES

The *Soundcraft Radio System* is especially designed for built-in installation in houses, and consists of a portable tuner, amplifier, record player, and one or more speakers, plus the antenna and necessary wiring. The portable tuner, about the size of a cradle telephone, is the only part of the system that appears in the rooms. Different speaker types and combinations can be selected to suit the particular house. Data sheets, showing wiring, installation diagrams, and dimensional details are provided so that the system can be installed by an electrician. Initial production provides for standard AM reception only, but an FM tuner will be provided later for converting to FM operation. Reeves Sound Studios, 10 E. 52nd St., New York, N. Y.

INCINERATOR

For reducing garbage and refuse to a fine ash, the *Waste-King* residential incinerator is installed flush with the wall in the base of the house chimney. In this way, advantage can be taken of a strong natural draft. A gas burner is built into the unit for use when needed to dispose of exceptionally wet loads. Grates and front are of cast iron; and case is of one-piece welded construction. A built-in mesh traps escaping fly ash. Where the wall-style incinerator is impractical, a floor unit which connects with the chimney may be used. Incinerator Products Co., 657 S. Post Ave., Detroit 17, Mich.

ALUMINUM WIRING

A new type of rubber insulation with increased heat resistance has been developed for use on aluminum wiring to replace copper wiring during the current acute copper shortage. The National Electric Code has long recognized and approved aluminum for electrical conductors, but until recently the higher current capacity of copper as compared with that of aluminum has restricted its general use for insulated wire and cable. With the development of a Type RH heat-resisting insulation, rated at 75° C. instead of the usual 60° C., there is no longer a safety requirement to increase the conductor area of aluminum to compensate for its lower conductivity (84 per cent that of copper). The corresponding power loss, of course, remains unchanged.

Aluminum wiring is available in all sizes up to 1,000,000 CM, starting at size 12, and is made with standard strandings. Dimensions and finishes remain the same as for ordinary building wire. Hazard Div., Okonite Co., Passaic, N. J.

FINNED RADIATION

Type W1 Extended Surface Radiation has been added to the list of Webster products for heating systems. It is completely nonferrous, being made of specially annealed copper tubing, aluminum fins, and brass couplings. Tubing is 1 $\frac{1}{8}$ in. outside diam., .035 in. wall thickness, and good for saturated steam pressures up to 100 lb. per sq. in. and temperatures up to 350° F. Fins are 3-in. squares, rib-reinforced, and made of .020-in. aluminum. Standardization is obtained through use of only one tube diameter and one fin size. Units are available in 5 lengths from 2 ft. to 6 ft., incl. for steam and hot water heating in places where floor or wall space is limited. Also manufactured are brackets, offset adapters, and covers. Warren Webster and Co., Camden, N. J.

SEALING COMPOUND

Para-Plastic, the hot-poured rubber seal for concrete expansion joints, is now manufactured in the following colors: green, red, gray, cream, yellow, and black. Serviced Products Corp., 6051 W. 65th St., Chicago 38, Ill.

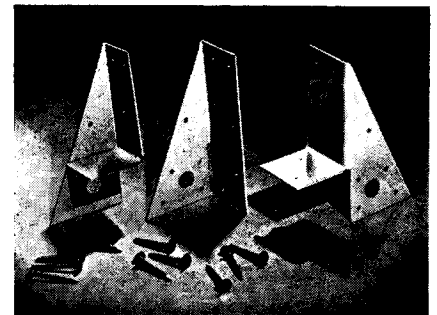

Timber connectors for increased rigidity

FRAMING ANCHORS

Timber connectors, known as *Trip-L-Grip* framing anchors, have been developed to increase the rigidity around window and door openings and increase the strength of floor and wall framing in house construction. The anchors are made of 18-gauge zinc-coated sheet steel and are joined to the wood with non-splitting nails. Laboratory tests at Georgia Tech are reported to have demonstrated their effectiveness for joining joists to beams, beams to posts, studs to sills, rafters to plates, studs to girts, and for making other house framing connections. The anchors are said to fit naturally into at least 90 per cent of house framing joints. If connections are at angles, flanges can be bent accordingly. Timber Engineering Co., 1319 18th St., N.W., Washington 6, D. C.

(Continued on page 168)

ADVANCES IN HOUSE LIGHTING

By E. W. Commery, General Electric Company

A LABORATORY for the study and presentation of latest techniques in residential lighting has been created at Horizon House in Nela Park, Cleveland. From earliest planning stages to completion, the architectural, decorative and lighting schemes were developed together in the hope of reaching new heights of correlated development. It is not a "model home" but a practical laboratory which we hope will lift design horizons for future use of light as a brilliant decorative medium and as a functional competitor of daylight.

The design, furnishings, and lighting have certain simply stated goals:

1. To fuse measured illumination with lighting qualities that aim to provide the greatest physical and emotional comfort. (The actual quantitative values are in accordance with the recommended practice of the Illuminating Engineering Society.)

2. To blend the mechanics of lighting equipment into the completed interior, combining function and esthetics.

3. To employ a number of new light sources, both fluorescent and incandescent, in ways that provide new effects and improved performance.

4. To demonstrate more fully the great range of possibilities for effective use of light and lighting in residential interiors.

In developing answers to objective (1), over 100 footcandles of light have been attained at several places in the living-dining room where close visual work might be carried on. Actually this degree of illumination can be supplied over limited areas beneath any one of the ceiling downlights by using 150-watt projector-spot lamps. For a broader spread of lighting, the 150-watt projector-flood lamp may be used; its use reduces the illumination to about one-third. To fuse local lighting with general lighting and to assure proper brightness contrasts, cove lighting and a perimeter ceiling band have been used. The cove light alone supplies an average of 10 footcandles from 8 Slimline fluorescent lamps, each 64 in. long. Floor and table lamps also supply a general distribution of light to reduce brightness-ratios, which high local illumination values create. Any of these systems may be used alone.

Freedom from obtrusive hardware, fastenings, and other mechanical elements is obtained through careful at-



Living-dining room of Horizon House, designed to test and demonstrate the effectiveness of latest residential lighting techniques. Room designs by M. L. Gormley

tention to details. (See page 151). The cove lights, perimeter wall lights, and ceiling downlights may all be opened and closed for cleaning and lamp renewal without fear of disfiguring the ceiling, wall, or woodwork finishes.

Fluorescent lighting has been developed to illuminate the room completely for both "effect" lighting and functional lighting. Fluorescent lighting enters into every room of the house with a graciousness that is actually surprising.

Of first importance is the wall color, derived from the color one sees on the inner layers of birch bark. Results show that completely successful rooms can be created when all selections of color

for an exacting interior are made in compartments illuminated with incandescent and fluorescent lamps.

At present, fluorescent lamps (White 3500° K) are used for all general distributions of light. For some of the more localized areas such as alcoves and niches, 1500° K lamps are used.

It was not many months ago that small-diameter fluorescent lamps were made available. Their applicability to many types of lighting problems that have always been awkward to handle makes for ease of design and installation, especially in structural types of work. The circular fluorescent lamp also adds immeasurably to the designer's tools.

(Continued on page 151)

Careful selection of colors was made for best results under fluorescent lighting

Description of Principal Colors	Munsell* Color Notation
Wall paint—pale grayed yellow-red.....	8YR 8/4
Carpet—sage.....	5B 6/1 to 5B 7/1
Painted tops of desk, fireplace, cabinets—horizon blue.....	5BG 7/3
Wood—fireplace, cabinets, dining table, desk, large coffee table—burled maple.	
Davenport—ice blue.....	5BG 7/4
Pair of fireside chairs—grayed blue.....	7BG 5/2
Love seat, desk chair, large wing lounge chair—flamingo red.....	4R 5/9
Lounge chair in front of desk—citron.....	10Y 8/5
Leather dining chairs—citron.....	9Y 7/6
Drapery background—citron.....	10Y 8/6

*Munsell Book of Color: A Revision and Extension of the Atlas of the Munsell Color System, Standard Edition of 1929.

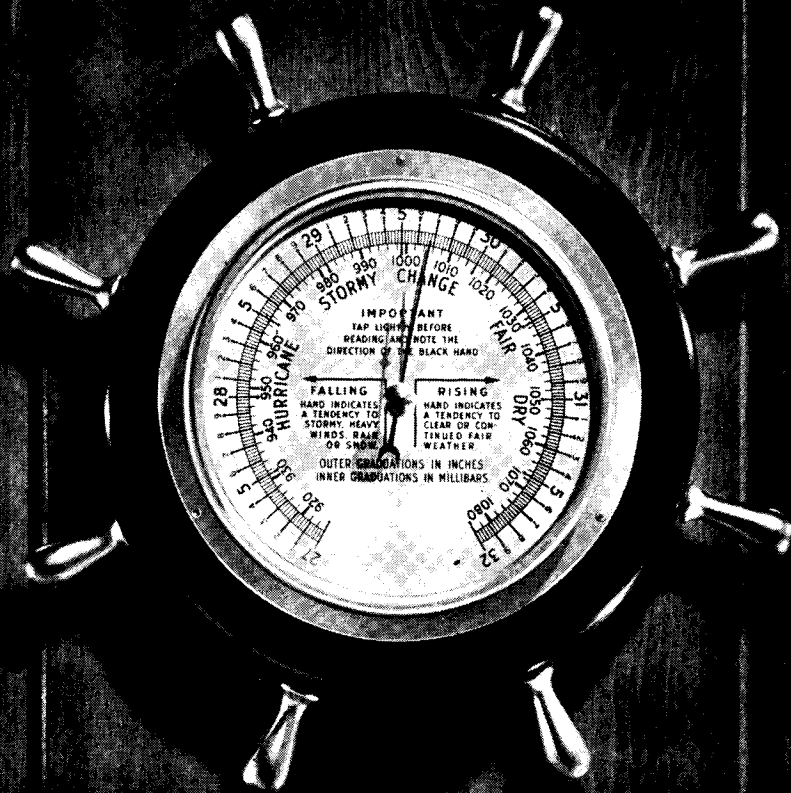

It's what's inside that Counts!

QUALITY in a barometer shows up in the accuracy of its readings. And this accuracy depends on delicately adjusted mechanisms *inside* the instrument.

With building products, too, quality of performance is determined by what's *inside*. Your eye seldom sees the values that make the important difference.

That's why building-wise people insist on Celotex Building and Insulating Products. They know the raw materials which go into Celotex products are the finest that nature can grow and man can refine.

They know, too, that rigid production controls all along the line *guarantee* the uniformly high quality of every product bearing the Celotex name.

Tireless laboratory research perfects materials and methods still *more* . . . helps to maintain Celotex leadership year after year.

These, plus more than a quarter of a century of

building materials "know-how," are the invaluable ingredients in every Celotex Product.

They make a big difference in performance . . . in long life and low cost maintenance. A difference that has proved its value on hundreds of thousands of building jobs of every kind.

* * *

There aren't enough of these famous Celotex products to go around *now*—but our plants throughout the country are working day and night to increase production. Everything possible is being done to speed the time when we can supply you with all the Celotex products you need.

Building Board
Interior Finish Boards
Celo-Siding
Rock Wool Insulation

Celo-Rok Wallboard
Celo-Rok Anchor Lath and Plaster
Cemesto Flexcell
Triple Sealed Shingles

CELOTEX
REG. U.S. PAT. OFF.
BUILDING PRODUCTS

THE CELOTEX CORPORATION • CHICAGO 3, ILLINOIS

VIZ-AID...

22" Knockouts

*on every chassis...
How easy to
install!*

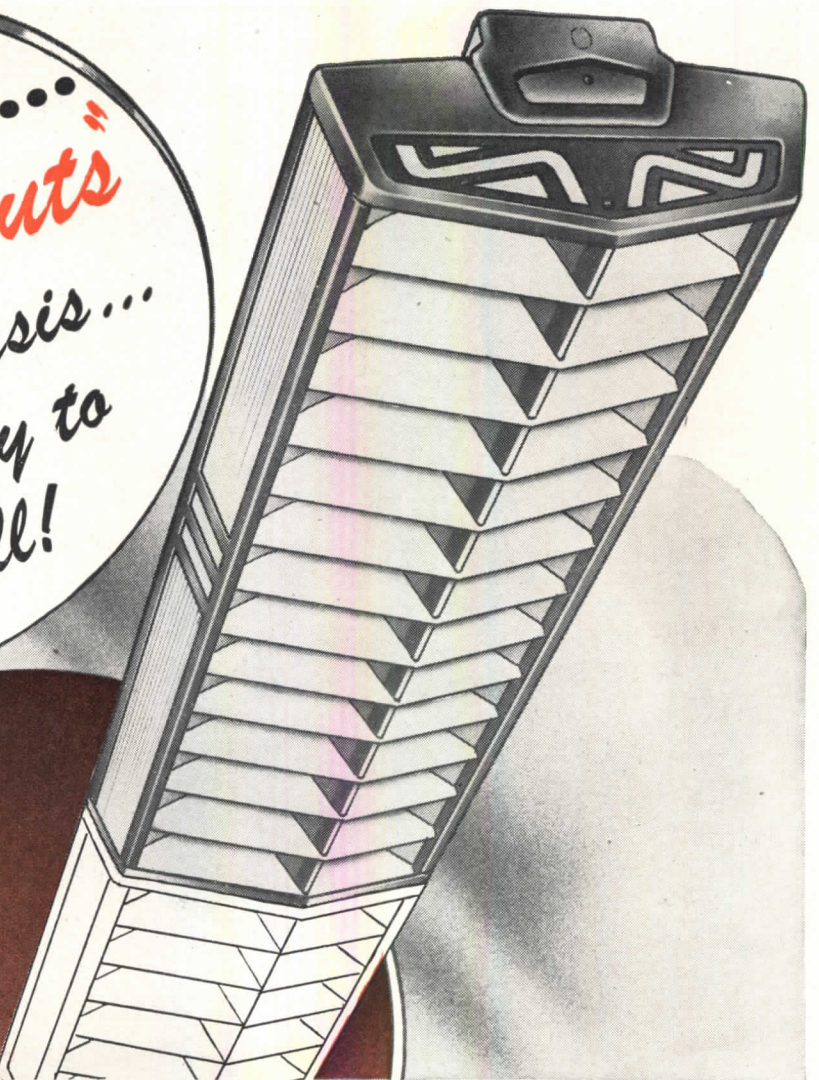

You'll find one wherever you need it . . . and all wire feeds are ready-bushed. All holes and knockouts are die-stamped in one operation for perfect alignment.

VIZ-AID commercial fixtures . . . for continuous or unit mounting . . . surface or suspension . . . two 40- or two 100-watt lamps. U. S. Patent Nos. D-138990, D-143641 and 2411952. Request Bulletin 10-B-1 for complete details.

Day-Brite Lighting, Inc., 5465 Bulwer Ave., St. Louis 7, Mo.
Nationally distributed through leading electrical supply houses.

In Canada: address all inquiries to Amalgamated Electric Corp. Ltd., Toronto 6, Ontario.



IT'S EASY TO SEE WHEN IT'S

DAY-BRITE

Lighting

HOUSE LIGHTING TECHNIQUES

Photos and drawings from "Horizon House,"
General Electric Co., Nela Park, Cleveland

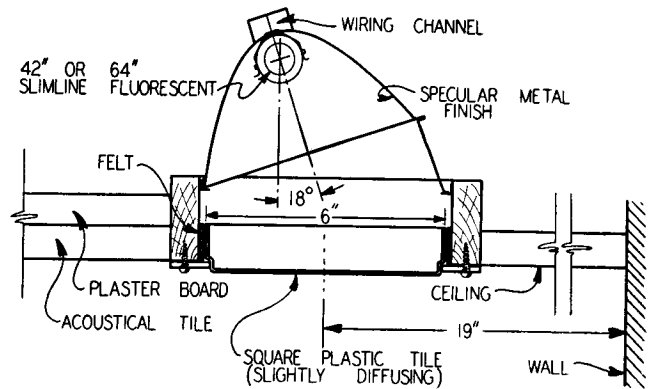

Ceiling Slot Lighting

Narrow luminaire slot in ceiling, fitted with crystal-etched plastic tile, furnishes diffused light upon nearby wall

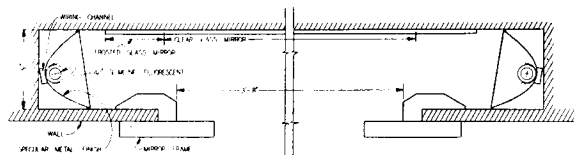
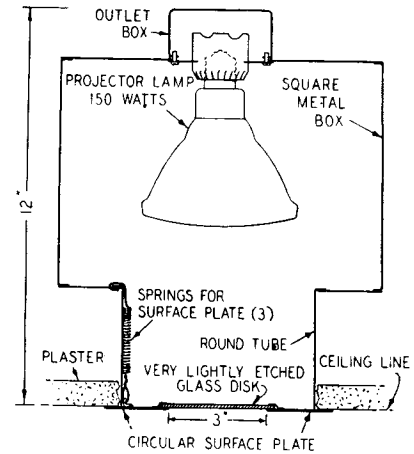

(Above) Spot Lighting
(Left) Cross Lighting

Projector lamps for dramatic effect and supplemental lighting; recessed tubes for brilliant cross-lighting of mirror

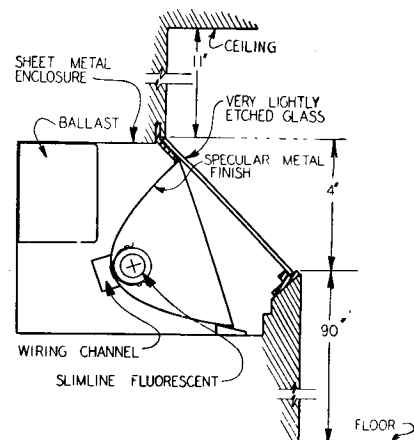

Cove Lighting

Offset design for cove lighting gives even wall brightness above and below cove. Note absence of "hot spots"

(Continued on page 153)

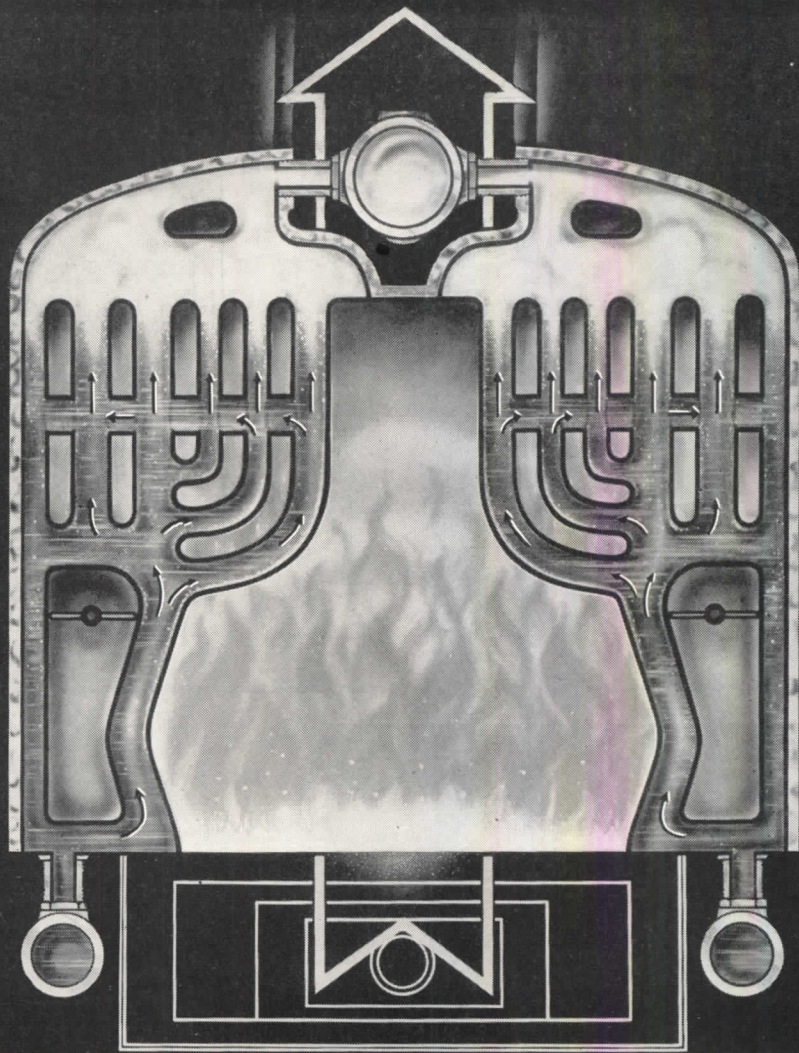

No. 44 Mills Water Tube Boiler

Everything's on the up and up!

When water gets hot it wants to go *up*, and it naturally takes the easy way up — the vertical way — if given a chance. That's why H. B. Smith Cast-Iron Boilers are designed with *vertical* water tubes, for faster water circulation, faster steaming.

There's another important reason for this vertical construction . . . soot just won't cling to a smooth, vertical surface. So H. B. Smith sections are practically self-

cleaning; the soot-free heating surface takes maximum heat out of the hot flue gases. And within the *vertical* water tubes, any foreign deposits flow freely to the return drums from which they are easily flushed.

That's the vertical story. For more important reasons why professionals recommend H. B. Smith Cast-Iron Boilers for industrial, institutional, commercial and residential heating, write for your free catalog.

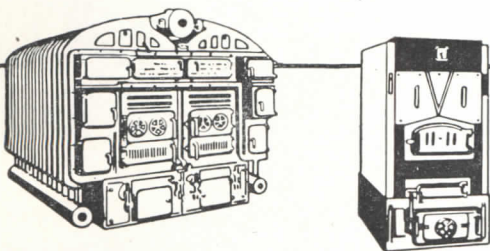

H.B.
Smith
CAST IRON BOILERS

THE H. B. SMITH CO., INC., 62 Main Street, Westfield, Mass. Offices and Representatives in Principal Cities

HOUSE LIGHTING TECHNIQUES

(Continued from page 151)

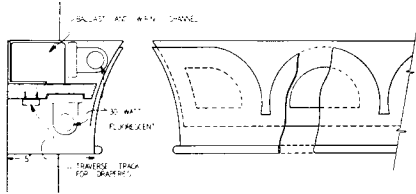

Valance Lighting

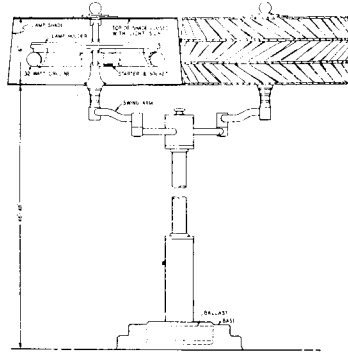

Twin Desk-Chair Lamp

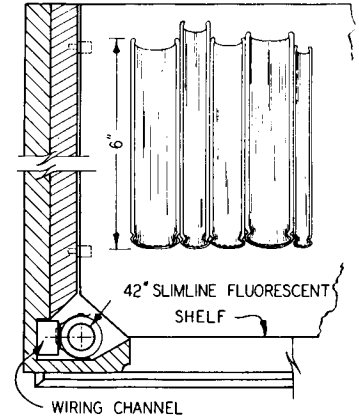

Bookcase Lighting

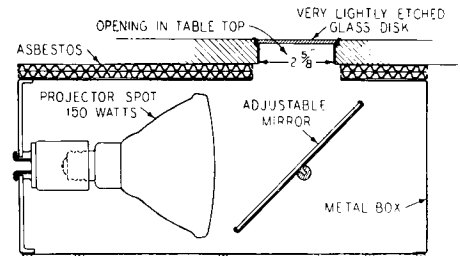

Reflected Downlighting

Dining table with built-in light box (sketch) which directs light upward to ceiling mirror for diffused downlighting

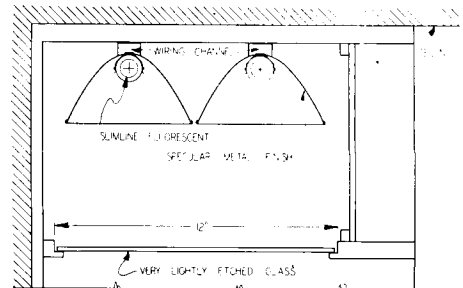
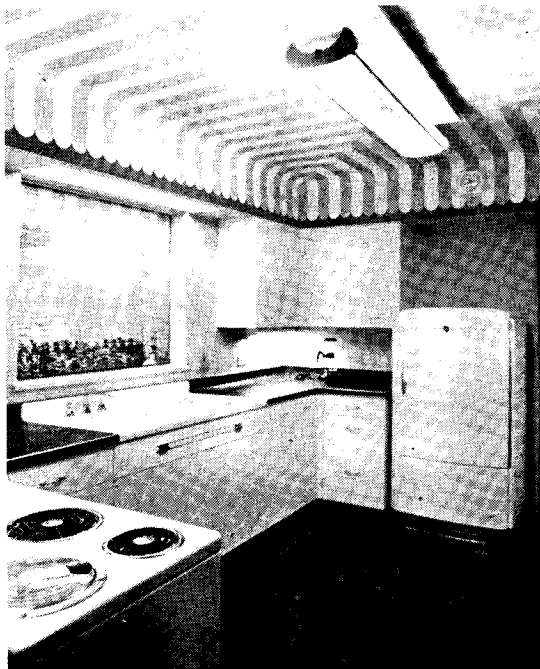

Ceiling Panel Lighting

Double row of fluorescent tubes above etched glass panel, for double or single use. Left: Kitchen. Right: Living room.



MANUFACTURERS' LITERATURE

CELLAR USES

How to Make the Most of Your Cellar. Descriptive booklet on the uses to which a basement can be put in addition to such utility uses as storage, heating and laundry. Suggestions include: hobby or work shop; gymnasium; shooting range; recreation room; playroom; "theater" for home movies; "cold cellar" for storing fruit, vegetables, preserves and wine. Advantages of an outside entrance to the cellar, construction features of the Bilco outside cellar door and cellar stair units. 20 pp., illus. The Bilco Co., 164 Hallock Ave., New Haven 6, Conn.* 10 cents.

DRAWING AID

(1) **A Short Cut to Perspectives with the Pomeroy Stereograph;** (2) **What the Sensational Pomeroy Stereograph Will Do for You.** Description of a new drawing instrument said to produce perspectives to hair-line accuracy without vanishing points, grids, outriggings or other accessories. Folders explain operation of the machine, illustrate how it works. 4 and 20 pp., illus. Pomeroy Stereograph Co., Inc., 315 Ferguson Bldg., Cleveland 14, Ohio.

ELECTRICITY

Bulldog Feeder and Plug-in Bus-tribution Duct for Bus Duct Electrical Distribution (Bulletin 462). Bulletin on a decentralized, prefabricated secondary electrical distribution system, its features, installation, units and fittings; typical installations. 24 pp., illus. Bulldog Electric Products Co., 7610 Jos. Campau Ave., Detroit 32, Mich.*

FLOORING

Tile-Text Asphalt Tile: Floors that Endure. Specifications and general information on a line of asphalt tile flooring for home, office and industrial use, and plastic asbestos wall tile, plastic tile flooring. Preparation of foundations, maintenance data, colors and patterns. 16 pp., illus. The Tile-Text Co., Inc., Chicago Heights, Ill.*

GLASS, PAINTS, METALS

Pittsburgh Data Sheet Handbook. Looseleaf folder containing individual sections on the various glass, paint and metal products of the Pittsburgh Plate Glass Co. and Pittsburgh Corning Corp. All factual information concerning the products condensed in ready reference form. Installation procedures include a

number of actual details. Open specification for glass and glazing, and basic specifications for painting are included. Pittsburgh Plate Glass Co., 632 Duquesne Way, Pittsburgh 22, Penn.*

HEATING

Panelaire Radiant Panel Heating. A consumer booklet describing the advantages of radiant panel heating, how it works, what equipment is needed and how it is installed. General information on heating principles and humidity; a 24-hour humidity and temperature graph taken in a Panelaire-heated home. 20 pp., illus. International Heater Co., Utica 2, N. Y. 25 cents.

Rittling Magna-Fin Convectector (Catalog MFC-CI). Complete information on convectors combining copper or steel tubing and aluminum or steel fins. Where used, advantages claimed, sizes, suggestions for piping connections, steam and hot water ratings tables, engineering data. 8 pp., illus. The Rittling Corp., 1292 Niagara St., Buffalo 13, N. Y.

There'll Come a Day — and that Day is Tomorrow! A humorous account in verse of the difficulties a manufacturer of heating controls met with in getting raw materials. 20 pp., illus. Minneapolis-Honeywell Regulator Co., Minneapolis 8, Minn.*

INSULATION

(1) **Ferro-Therm Steel Insulation;** (2) **Ferro-Therm Steel Insulation — Shield of Protection for the Modern Building;** (3) **Ferro-Therm Steel Insulation for Refrigerated Construction.** Three pamphlets describing the properties and uses of steel insulation. Charts showing its effectiveness; report on tests; installation information; advantages claimed. 16, 4 and 12 pp., illus. American Flange & Mfg. Co., Inc., 30 Rockefeller Plaza, New York 20, N. Y.*

"It's NO Joke, Son." The story of Cellulite cotton insulation as whimsically told by Senator Claghorn of radio fame. Gives general information about insulation, advantages claimed for Cellulite, installation data, etc. 16 pp., illus. The Gilman Brothers Co., Gilman, Conn.*

LIGHTING

Guth Lighting Catalog 44-A. Current line of fluorescent and incandescent lighting equipment. Includes general fluorescent data, complete specifica-

tions for each unit in the line, engineering information, maintenance and mounting data, general lighting design information including a room index table classifying rooms according to their proportions, and giving a formula for the determination of lumens required. 44 pp., illus. Edwin F. Guth Co., 2615 Washington Ave., St. Louis 3, Mo.

PAINTS

Architects Condensed Painting Guide. Folio containing in condensed form descriptions of the finishes required for various surfaces, materials and conditions, and other pertinent data on paint and painting. 4 pp., illus. M. J. Merkin Paint Co., Inc., 1441 Broadway, New York 18, N. Y.

PLANNING IDEAS

Room of the Month Ideas — March. First in a series of folders featuring original room designs: designs for a bathroom with a locker-type storage compartment for soap, tissues and cleansers, a built-in cabinet for drying small articles of clothing, an angle bath and matching lavatory, etc. 4 pp., illus. American Radiator & Standard Sanitary Corp., P.O. Box 1226, Pittsburgh 30, Penn.*

REFRIGERATION

Ice and Frost (Bulletin 147-B). A brief catalog of Frick freezing systems, giving general information, sections and plans, and a chart showing moisture-carrying capacity of air at low temperatures. 10 pp., illus. Frick Co., Waynesboro, Penn.

ROOFING, SIDING

Flintkote Building Materials: Roofing, Siding, Insulation. Bulletin on a line of asphalt strip and individual asphalt shingles, asbestos-cement shingles and sidings, insulated sidings, built-up roofing, roll roofings and sidings, decorative insulation board, structural insulation board and insulating wool. Specifications table for each product in the line, general information, advantages claimed. 14 pp., illus. The Flintkote Co., 30 Rockefeller Plaza, New York 20.*

STEEL DECK

Mahon Steel Deck for Roofs, Sidewalls, Partitions, Ceilings, Floors. Catalog giving full information and specifications, installation instructions, recommended applications, features. 16 pp., illus. The R. C. Mahon Co., Detroit 11, Mich.*

THERMOMETERS

Thermometers and Pressure Gauges (Catalog No. 6707). Description of a line of vapor, gas and mercury actuated thermometers and pressure gauges. Cutaway illustration

(Continued on page 178)

* Other product information in Sweet's File, 1946.

26 standard sizes

Simplify Specifications

...mean Quick Delivery

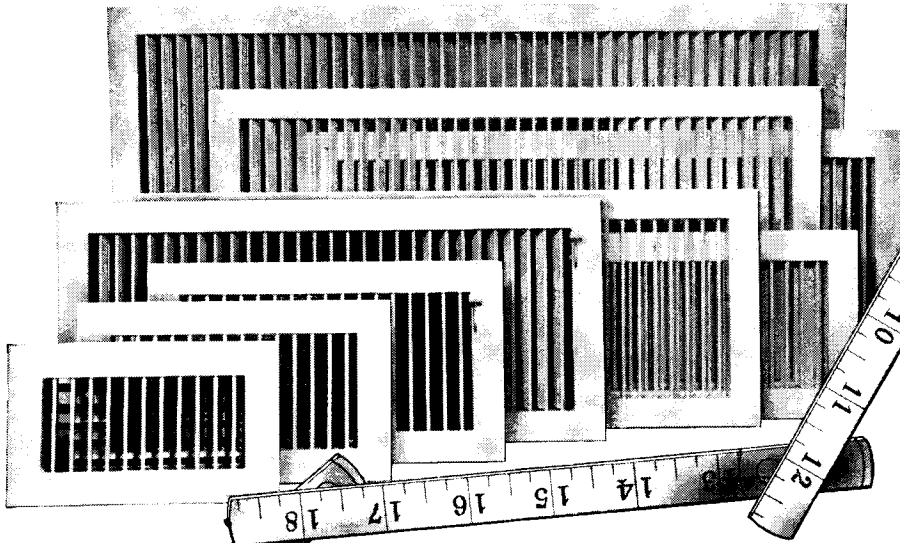

Tri-Flex

GRILLES and REGISTERS

USE Tri-Flex...
IN THE 26 STANDARD SIZES*

- 8 x 4
- 10 x 4
- 10 x 6
- 12 x 4
- 12 x 5
- 12 x 6
- 14 x 4
- 14 x 5
- 14 x 6
- 16 x 5
- 16 x 6
- 20 x 5
- 20 x 6
- 20 x 8
- 24 x 5
- 24 x 6
- 24 x 8
- 24 x 10
- 24 x 12
- 30 x 6
- 30 x 8
- 30 x 10
- 30 x 12
- 36 x 8
- 36 x 10
- 36 x 12

*for non-standard sizes, write Factory

Size standardization of Tuttle & Bailey TRI-FLEX Grilles and Registers not only results in quicker, easier specifying . . . but more economical production methods mean speeded-up deliveries, cost savings for your client. Surveys indicate that air conditioning Architects, Engineers and those responsible for the installation of air conditioning systems agree that the twenty-six sizes listed as standard for TRI-FLEX will meet requirements of the majority of commercial, industrial and institutional applications.

The TRI-FLEX line, made up of various combinations of three flexible units — grille, deflector blades, multi-shutter damper — provides really effective control of air distribution *at the vital point of air delivery.*

For performance, attractive appearance, economy, availability . . . be sure to specify TRI-FLEX for your next air conditioning job. Your client will appreciate the choice. WRITE TODAY for a copy of Bulletin No. 47TF . . . full description of all TRI-FLEX units, detailed engineering data, list prices, complete information for specifying and installing.



NEW BRITAIN, CONNECTICUT

40

PAGES OF REFERENCE ON

DOORS FOR EVERY NEED.

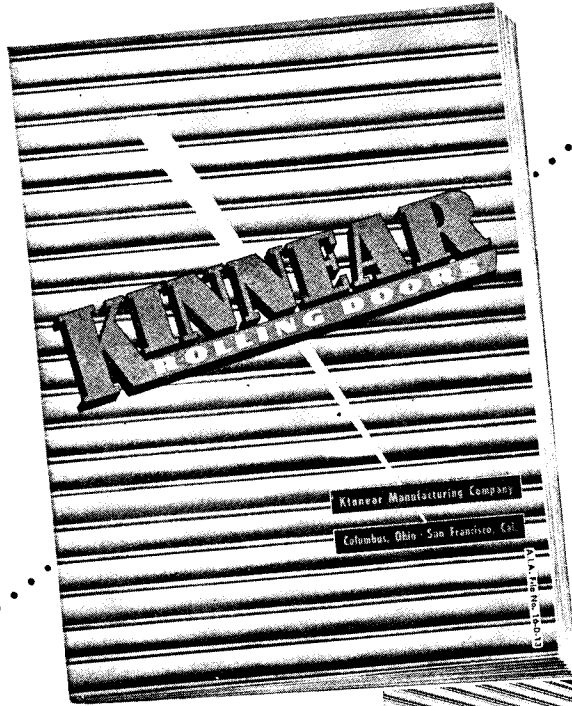

Concise, handy data to have on tap . . .

Get yours today!

This helpful new book will give you latest comprehensive details on a complete range of upward-acting doors for every type of building, old or new—famous Kinneear Steel Rolling Doors with motor or manual operation, Rolling Fire Doors, sectional-type doors, and protective rolling grilles. Send for your free copy of this new Kinneear Catalog today!

THE KINNEEAR MANUFACTURING CO.

Factories:
 1860-80 Fields Ave. • Columbus 16, Ohio
 1742 Yosemite Ave. • San Francisco 24, Calif.

Saving Ways in Doorways
KINNEEAR
 ROLLING DOORS

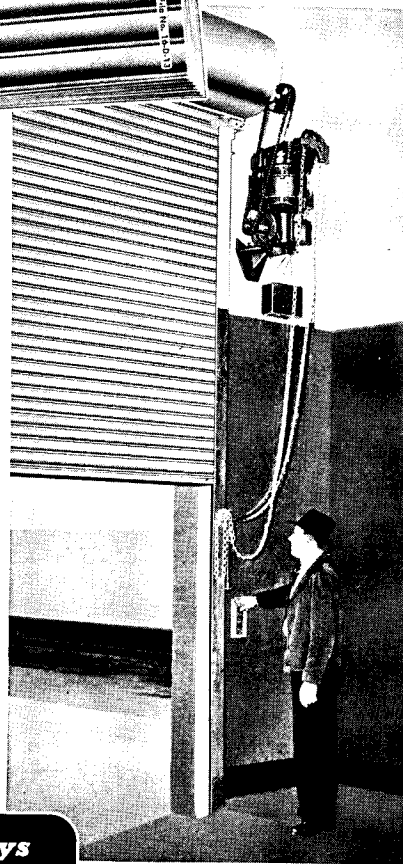

Offices and Agents in all
 Principal Cities

THE RECORD REPORTS

(Continued from page 16)

thermore, predict these four groups, at least \$705 million will be expended on all types of construction and public improvements in the Greater Miami area by the end of 1951.

By far the biggest item on the construction list is housing. The three counties of Dade, Broward and Palm Beach will build approximately 73,000 dwelling units within the five-year period at a cost of nearly a half billion dollars.

IOWA STUDIES CODES

Recently passed by both houses of the Iowa General Assembly and signed by Governor Robert D. Blue is a bill creating a Building Code Council to prepare a uniform state building code for Iowa. The proposed code is to be submitted to the 53rd General Assembly when it convenes in 1949.

In accordance with the provisions of the bill, Gov. Blue will appoint a 10-member council consisting of two engineers, two general contractors, two architects and four laymen at least two of whom shall be members of the General Assembly. A technical secretary will be employed by the Council to have general charge of the work.

The bill was passed following three years of consistent effort on the part of the sponsoring groups. Frank Kerekes, president of the Iowa Engineering Society is chairman of the State Building Code Central Committee, composed of representatives of 34 organizations including the Iowa sections of the A.I.A., the American Institute of Electrical Engineers, the American Society of Civil Engineers, the American Society of Heating & Ventilating Engineers, the American Society of Mechanical Engineers, the Associated General Contractors of Iowa, the FHA, the State Department of Health, the State Board of Education, etc.

ON THE CALENDAR

May 6-8: The President's Conference on Fire Prevention, Federal Works Bldg., Washington 25, D.C.

May 6-10: 2nd National Plastics Exposition and Annual Convention, The Society of the Plastics Industry, Coliseum, Chicago.

June 2-4: Semi-annual Meeting, American Society of Heating and Ventilating Engineers, Hotel del Coronado, Coronado, Calif.

June 12-22: 2nd annual Construction Industries Exposition and Home Show, Pan-Pacific Auditorium, Los Angeles.

June 16-19: Semi-annual Meeting,
 (Continued on page 158)

RIGHT ACROSS THE BOARDS

far-sighted
architects
are depend-
ing upon

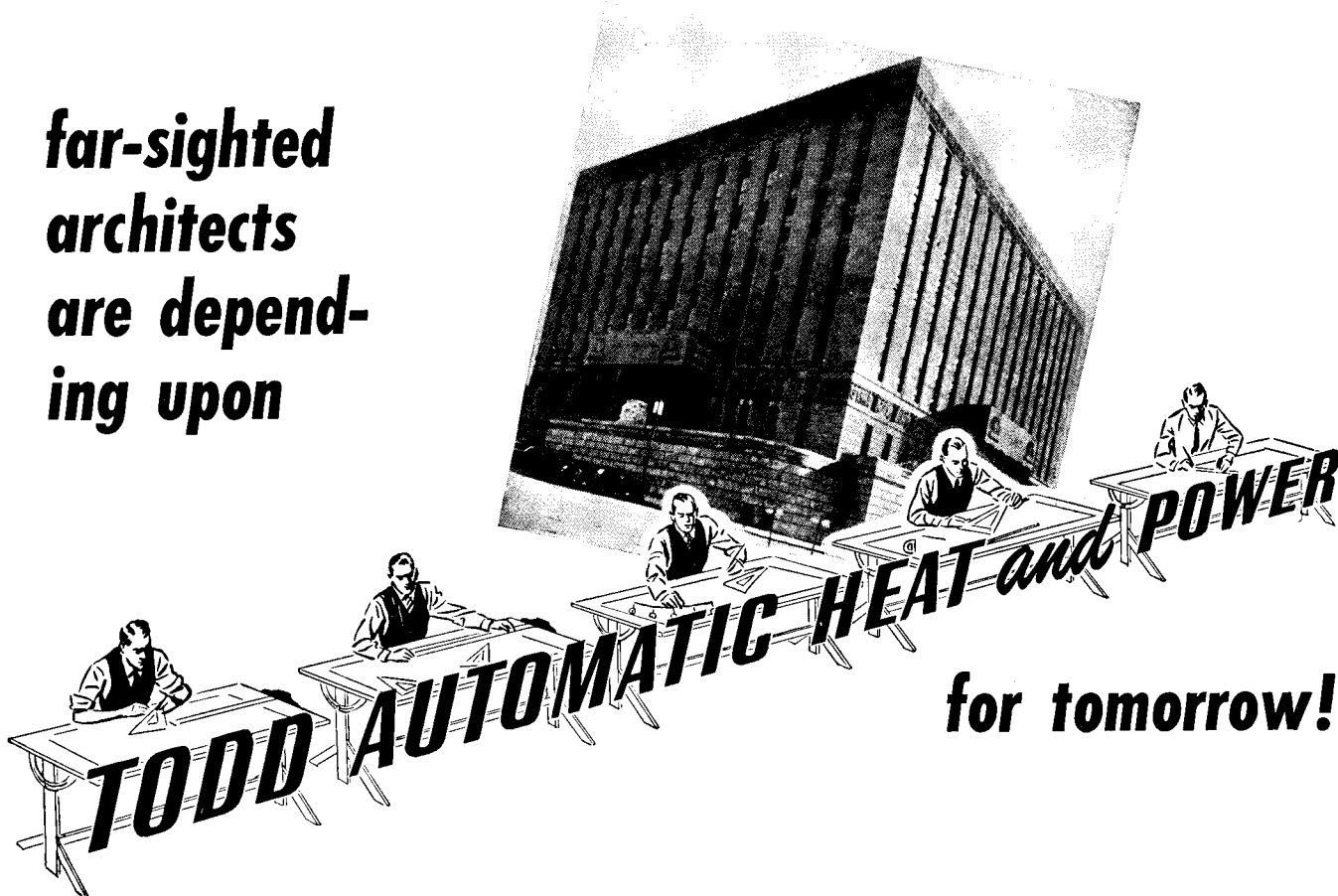

for tomorrow!

... maximum heat and power
with minimum fuel consumption

EVERYWHERE today the blue-prints of America's architects and engineers reflect keen recognition of the decisive role cheaper power and heat play in fixing tomorrow's price structures.

Many are finding Todd Automatic Oil and Gas Burners the most practical answer to boiler plant economy—for *three* reasons.

First, because Todd has developed combustion equipment which produces maximum power with

minimum fuel consumption. *Second*, because Todd provides trouble-free operation with exceedingly low maintenance costs. *Third*, because Todd manufactures a complete line of oil and gas burning equipment, tailored to meet any requirement.

Whether you are concerned primarily with new commercial, industrial or institutional structures, or with modernizations, call in a Todd engineer for consultation. He will cooperate with you in every way in meeting the individual needs of your client's power plants.

COMBUSTION EQUIPMENT DIVISION TODD SHIPYARDS CORPORATION

81-16 45th Avenue, Elmhurst, Queens, N. Y.

NEW YORK, BROOKLYN, ROCHESTER, HOBOKEN, NEWARK, PHILADELPHIA,
CHARLESTON, S. C., CHICAGO, BOSTON, SPRINGFIELD, MASS., BALTIMORE, WASHINGTON,
DETROIT, GRAND RAPIDS, TAMPA, GALVESTON, MOBILE, NEW ORLEANS, LOS ANGELES,
SAN FRANCISCO, SEATTLE, MONTREAL, TORONTO, BARRANQUILLA, BUENOS AIRES, LONDON

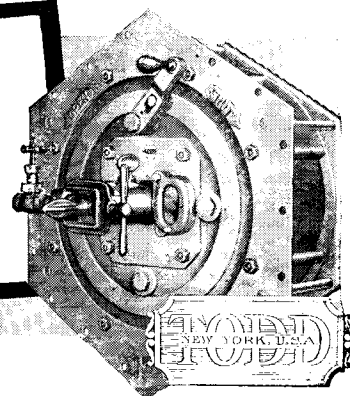

Don't Overlook

MICHAELS PRODUCTS in Your Building Plans

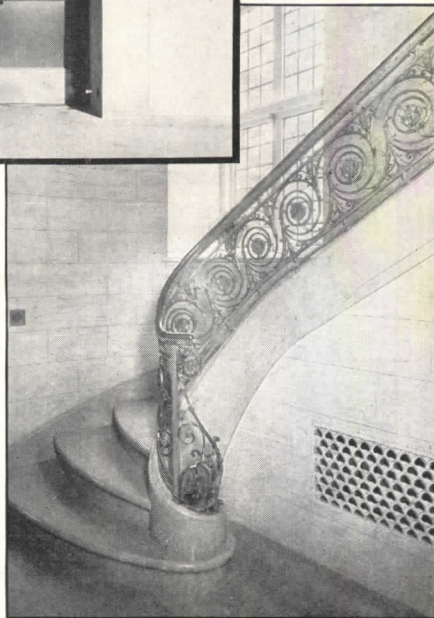
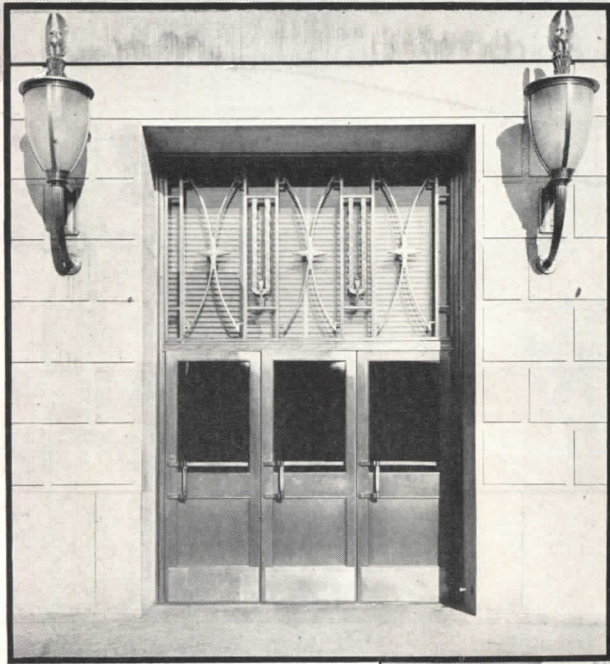

The manufacture of ferrous and nonferrous metal building products has always been a major part of our business. And now that restrictions are lifted, and materials obtainable, we offer to architects and builders a variety of bronze, aluminum and non-ferrous metal products. For specific requirements Michaels craftsmen will faithfully reproduce in metal the most intricate architectural designs. If your plans include metal products, write us.

MICHAELS PRODUCTS

Fixtures for Banks and Offices
Welded Bronze Doors
Elevator Doors
Elevator Enclosures
Check Desks (standing and wall)
Lamp Standards
Marquise
Tablets and Signs
Name Plates
Railings (cast and wrought)
Building Directories
Bulletin Boards

Stamped and Cast Radiator Grilles
Grilles and Wickets
Kick and Push Plates
Push Bars
Wrought Iron and Bronze Lighting Fixtures
Wire Work
Cast Thresholds
Extruded Thresholds
Extruded Casements and Store Front Sash
Bronze and Iron Store Fronts
Bronze Double Hung Windows
Bronze Casement Windows

THE MICHAELS ART BRONZE CO., Inc., 234 Scott St., Covington, Kentucky

Manufacturers since 1870 of many products in Bronze,
Aluminum and other metals

THE RECORD REPORTS

(Continued from page 156)

American Society of Mechanical Engineers, Stevens Hotel, Chicago.

July 7-13: 1st Annual Store Modernization Show, Grand Central Palace, New York City.

Sept. 1-4: Fall Meeting, American Society of Mechanical Engineers, Hotel Utah, Salt Lake City, Utah.

Nov. 3-7: 2nd International Lighting Exposition and Conference, Stevens Hotel, Chicago.

Dec. 2-5: Annual Meeting, American Society of Mechanical Engineers, New York or Atlantic City.

COMPETITION ANNOUNCED

An architectural competition of nation-wide artistic and historic significance has been announced by the Jefferson National Expansion Memorial Association, sponsors. Prizes totaling \$125,000 are offered to secure a design for a \$30,000,000 federal memorial to Thomas Jefferson and the pioneers of the western expansion of the United States. Site of the memorial is 80 acres now cleared in the downtown center of the St. Louis riverfront. George Howe, F.A.I.A., has been retained as professional adviser.

The competition is to be held in two stages. Participation in the first will be open to all architects who are citizens of the United States. Participation in the second stage will be limited to five finalists named by the Jury of Award; each of the five will receive \$10,000. Grand prizes at the end of the second stage will be awarded as follows: first, \$40,000; second, \$20,000; third, \$10,000; and two honorarium awards of \$2500 each.

Application blanks and complete information may be had from George Howe, Professional Adviser, The Jefferson National Expansion Memorial Competition, Old Courthouse, 415 Market St., St. Louis 2, Mo.

WITH THE A.I.A.

U.N. Committee Appointed

The A.I.A. has appointed a special committee to confer with officials of the United Nations regarding the U.N.'s urgent architectural problems. Members appointed, following a conference with Trygve Lie, secretary general of the U.N., are: Eric Gugler, chairman; Ralph Walker, and Edgar I. Williams, all of New York City.

Apprentice Training Endorsed

The A.I.A. has endorsed the federal government's efforts to expand the apprentice training program in the building trades as a means of preventing a short-

(Continued on page 160)

Products of
BORG-WARNER

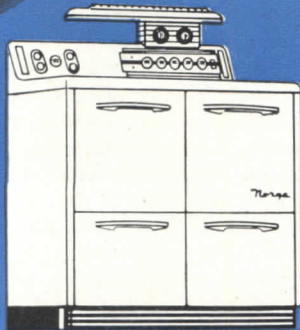

ELECTRIC RANGES

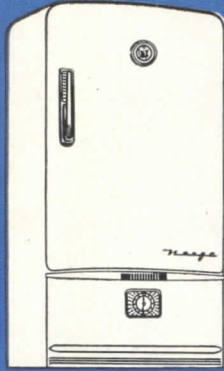

"ROLLATOR" REFRIGERATORS

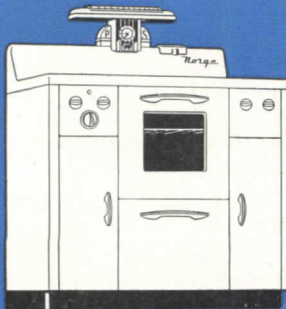

GAS RANGES



"RO-TA-TOR" WASHERS

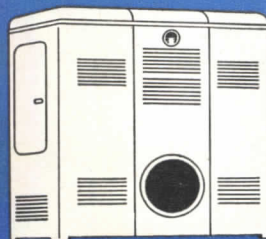

HOME HEATERS

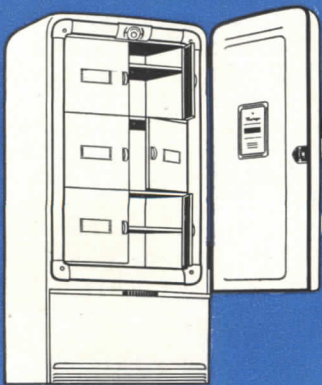

HOME AND FARM FREEZERS

CLEAN DESIGN

You, like the designers and engineers at Norge, know that "clean design" entails functional efficiency as well as symmetry of line and surface. Clean design characterizes all Norge products.

SEE
NORGE
BEFORE YOU BUY

Norge is the trade-mark of Norge Division, Borg-Warner Corporation, Detroit 26, Michigan. In Canada: Addison Industries, Ltd., Toronto, Ont.

**DUNHAM TEAMWORK
GIVES YOU
ACCURATE CONTROL
OF TEMPERATURES**



Like a baseball pitcher with a good "change of pace," the Dunham System provides variations in pressure, temperature and volume of steam — to maintain comfortable inside temperatures — as rapidly as changing weather conditions may require. This system operates automatically, with the efficiency of a smooth-working team, to assure you of heating that is highly satisfactory, economical and trouble-free. Bulletin 631 with complete details will be sent you upon request. C. A. DUNHAM COMPANY, 450 East Ohio Street, Chicago 11, Ill.

D547 2/3 E

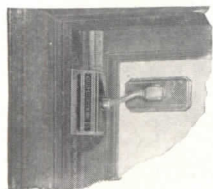

SELECTOR

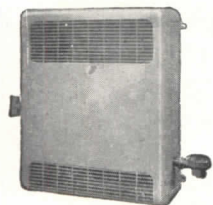

HEAT BALANCER



CONTROL PANEL

RESISTANCE THERMOMETER

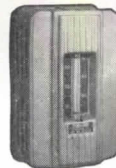

CONTROL VALVE

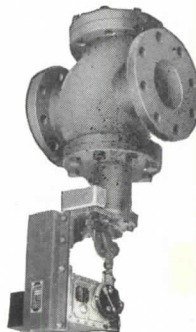

DUNHAM
HEATING MEANS BETTER HEATING

THE RECORD REPORTS

(Continued from page 158)

age of skilled construction workers. In a letter sent to members of sub-committees of the Senate and House Appropriations Committees which will pass on funds for apprentice training, the Institute said in part:

"We consider that the Apprentice Training Service of the Department of Labor has rendered and is rendering an invaluable service to the country in setting the pattern for, and assisting the augmentation of, apprentice training in the building trades. We also believe that the program of the Department in this respect represents a real accomplishment. It is our request that this Apprentice Training Service be continued — for the public good — and that the work so well done be recognized."

New W-E-T Bill Approved

The Taft-Ellender-Wagner housing bill has been given qualified approval by the Urban Planning Committee of the American Institute of Architects in a statement to the Senate Committee on Banking and Currency, according to an announcement by Louis Justement, chairman of the committee.

In endorsing the purpose of the bill, Mr. Justement stated that federal participation in housing is needed because neither private enterprise nor the municipalities can solve urban housing and redevelopment problems without financial assistance from the federal government. The statement approved the establishment of a National Housing Commission to coordinate government agencies having to do with housing, but suggested that the commission could function more effectively if it consists of five members rather than as set up in Title II.

The committee also suggested elimination of the section of the bill setting up new terms for financing housing for low-income families, on the grounds that they were contrary to sound mortgage practice.

FIRE SAFEGUARDS

Recommendations designed to minimize loss of life in hotel fires have been made public by the executive committee of the Building Officials Conference of America, Inc., following review of findings and conclusions of the Conference's committee on inquiries into disasters based on an investigation of the Wine-coff Hotel fire in Atlanta in December.

The Conference recommends, among other things: (1) the elimination or sealing of transoms in hotel guest rooms; (2) the protection of all floors by supervised watchmen's services, in lieu of adequate fire protection equipment provided with

(Continued on page 162)

ASBESTOS IN ACTION

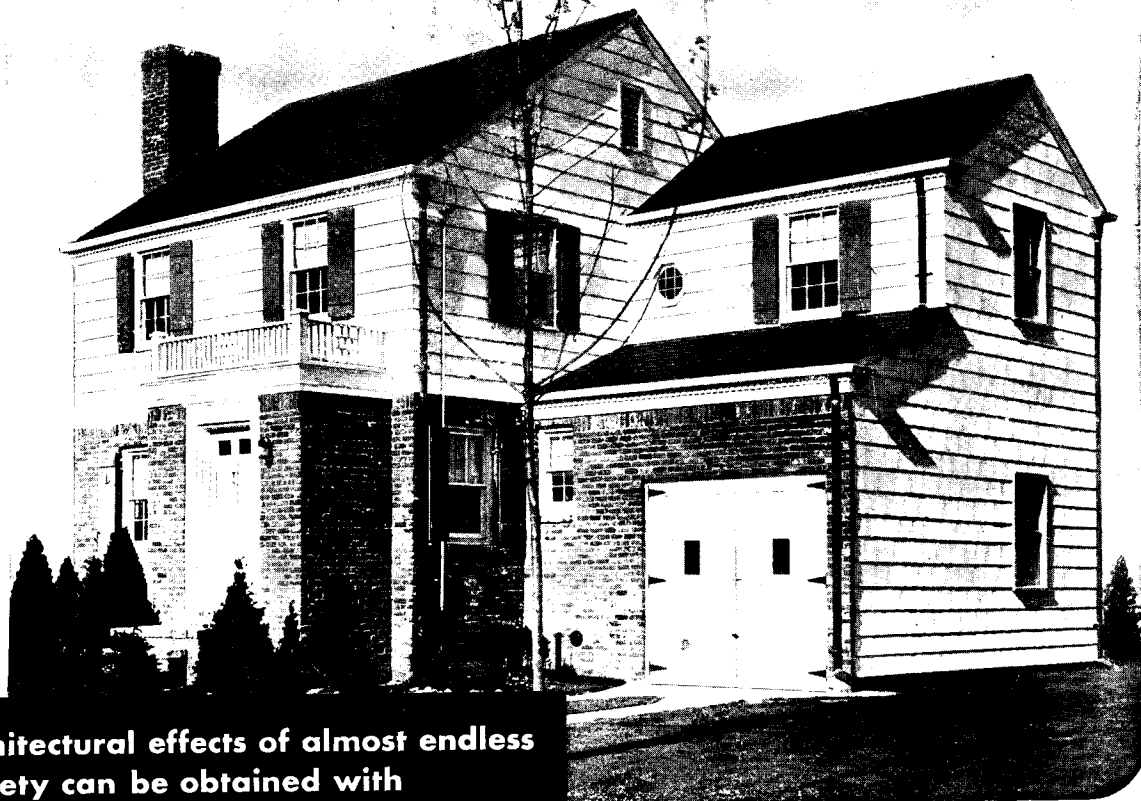

Architectural effects of almost endless variety can be obtained with

K & M "Century" ASBESTOS-CEMENT SIDING

• An interesting combination of brick and K&M "Century" Siding Shingles.

More and more architects are discovering that these attractive, time-resisting shingles are the most versatile and adaptable of all siding materials. For the number of interesting architectural effects is practically without limit.

Yet beauty and adaptability are but two of many factors that have made K&M "Century" Siding Shingles so popular among architects. Neither rain, hail, snow nor temperature extremes adversely affect them. They are proof against fire, rot, rodents, termites and other destroyers.

They require no protective paint and no maintenance. Being made of asbestos fibres and portland cement, they actually grow harder with age.

K&M "Century" Siding Shingles are supplied in color-fast shell white and gray tone... in quickly-applied 24" widths with straight or wavy butt line styles.

Write for full particulars regarding these and other K&M Asbestos-Cement products... K&M "Century" Roofing Shingles, K&M "Century" APAC sheet material.

* * * * *
*Original manufacturers of Asbestos-Cement
Roofing Shingles in this country*

KEASBEY & MATTISON
COMPANY • AMBLER • PENNSYLVANIA



automatic transmission of alarm to the fire department; (3) and the installation of fire vent flues and ducts to conduct superheated air and gases to a point of dissipation outside buildings.

AT THE COLLEGES

Fontainebleau Schedule

The Fontainebleau School of Fine Arts, Fontainebleau, France, has announced that its 1947 Summer School

for Advanced American Students in the Visual Arts will be held from July 1 to September 1. Under the direction of Jules Formigé and Jean Labatut, the summer session will include courses in architecture, painting, mural painting and fresco, sculpture and applied arts. Jean Labatut will serve as professor, and Georges Legendre as assistant professor of architecture.

Requests for further information and applications for admission should be

addressed to the New York office: Fontainebleau School of Fine Arts, 206 E. 62nd St., New York 21, N. Y.

Junior A.I.A.'s at Pratt

Thirty-three junior and senior students of the Department of Architecture, Pratt Institute, Brooklyn, N. Y., were inducted as members of the newly organized Student Associate Branch, Brooklyn Chapter, The American Institute of Architects, in the course of the Chapter's first joint meeting with the students held on February 25th.

The student group was organized by the A.I.A. chapter for fostering of fellowship and promoting cooperation and a spirit of unity between students of architecture and practicing architects, and to provide a means of intercourse between active members of the chapter and the students. Activities planned include inspection trips to new building projects, aid in finding employment under the mentor system, and discourses on architectural subjects by distinguished members of the profession. Membership in the student association is open to all junior and senior students who attend recognized schools of architecture in Brooklyn or who are residents of Brooklyn. Draftsman students of architecture who either reside in or are employed in Brooklyn are also eligible. Students who are interested in joining the group should communicate with Allan G. McTaggart, 26 St. James Pl., Brooklyn 5, N. Y.

Plastics Research

The College of Engineering of the University of Illinois and the Plastics Division of Monsanto Chemical Company have announced renewal for the third year of a contract wherein Monsanto provides funds for a fundamental research program on the dynamic fatigue characteristics of plastics. The research, under the direction of Prof. William N. Findley of the Department of Theoretical and Applied Mechanics, is intended to provide a better knowledge of the behavior of plastic materials under cyclic stresses, and to aid in choosing the best test methods for use in studying the fatigue properties of these important materials.

Lumber Yard Training

A reduction in the cost of building and better service to builders and buyers of homes and other new construction will result from the special training courses for employees of retail lumber yards which are being conducted at 13 leading colleges and universities. The four-week courses are sponsored by the Producers' Council and the National Retail Lumber Dealers Association, and are open to present and prospective employees of retail building materials concerns and to

(Continued on page 164)

KITCHEN PLAN NO. 42:

Forty-second of a series of successful mass-feeding plans.

The new 650-bed George Washington Memorial Hospital, Washington, D. C. is "Specialized Cooking Tool" equipped, not alone to furnish efficient food production, but also to promote cleaning-ease and fatigue-elimination.

**KEEP FOR
HANDY
REFERENCE!**

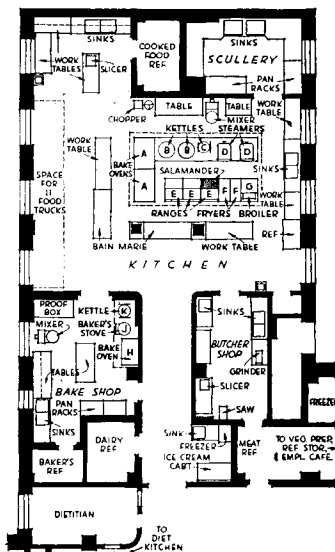

COOKING EQUIPMENT USED:

Main Kitchen:

- (a) 2 No. 959 BLODGETT GAS-FIRED ROASTING OVENS
- (b) 2 Stock Kettles
- (c) 1 Trunnion Kettle
- (d) 2 Vegetable Steamers
- (e) 3 Open Top Gas-fired Ranges, with one Gas-fired Ceramic Salamander
- (f) 2 Gas-fired Deep Fat Fryers
- (g) 1 Gas-fired Broiler

Bake Shop:

- (h) 1 No. 982 BLODGETT GAS-FIRED BAKE OVEN
- (j) 1 Gas-fired Confectionery Stove
- (k) 1 Trunnion Kettle

Installed by W. F. Dougherty & Sons, Philadelphia, Pa.

Efficient production of food, the highest standards of sanitation, the easiest working conditions, result from the use of Specialized Cooking Tools. In this plan the two No. 959 Blodgett Ovens in the cooking bank provide 55.8 square feet of meat and vegetable capacity — equal to 13 sections of ranges. The bake shop is equipped with Blodgett's flexible, 8-pan, 2 section oven with four decks. The No. 959's are used for meat and vegetable preparation — an increasingly popular oven adaptation



The G. S. BLODGETT CO., Inc.

50 Lakeside Avenue

Burlington, Vermont

Send for your copy of the new, deluxe edition of Case Histories of Successful Mass-Feeding Installations Now!

What - ALL THIS IN A SMALL HOME ??

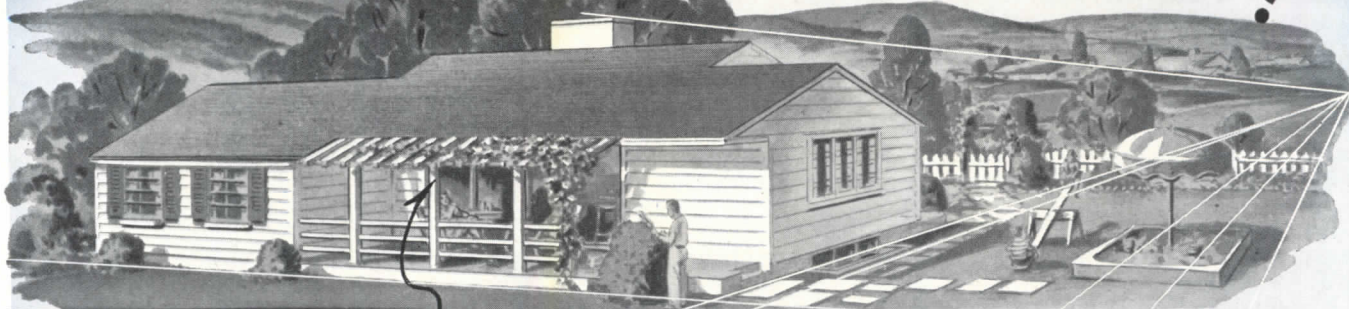

the HOUSE

Terrace, vine-roofed in summer, open for solar warmth in winter.

Snack bar with cupboards on kitchen side, bar stool space opposite. Collapsible curtain on track in ceiling separates living areas from kitchen when desired.

Right! This compact little "castle" has all the "modern living" advantages of a larger home — it's easy to look at, easy to live in and easy to build. And because every foot of space has been put to use, this home can be built on a small lot!

The designer of this house put a lot of smart ideas into it — and none is shrewder than the provision made for coal heating. This foresight allows the owner at the outset to heat by any fuel he chooses — but prevents his home from being "cut adrift" should he want to convert to coal later, when stoker developments, cost differentials or scarcity of other fuels convince him of the advantages of Bituminous coal. This little home has a chimney with a flue capacity sufficient to burn coal efficiently, and sufficient space for immediate or eventual stoker installation and coal storage. When the owner makes this installation and uses coal — Fuel Satisfaction — he has not "painted himself into a corner!"

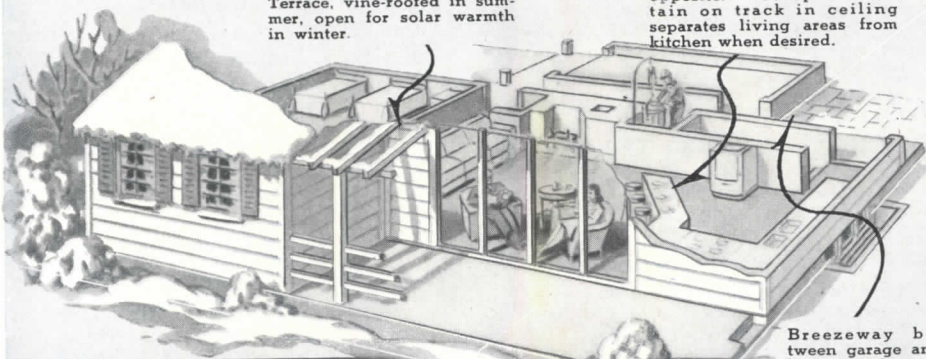

the LIVING AREA

Chimney with flue capacity for efficient coal burning.

Breezeway between garage and living section.

Ash hoist — a "twist of the wrist" lifts ashes to the breezeway.

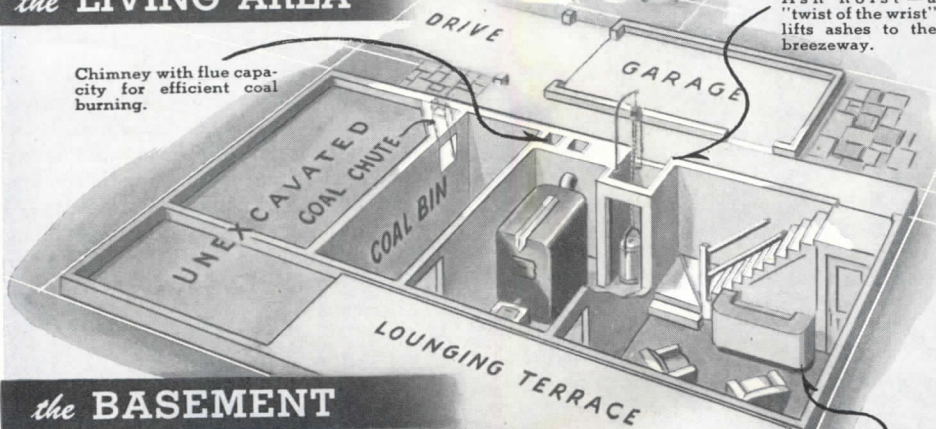

the BASEMENT

BUILT FOR FUEL SATISFACTION

Fuel Satisfaction is the superior, all-purpose Bituminous coal mined along the N. & W. It is economical, clean and abundant in supply.

Initial Cost Economy. A hand-fired coal furnace costs less than any other method.

Automatic Heat. Coal stoker cost is low.

Automatic Heating. Over a period of time, the cost of stoker heating is no greater than any other automatic plan. Economy of fuel is the difference.

Clean, smokeless fuel. Coal is sized, cleaned and dust-proofed at the mine.

Other fuels may become scarce—but there is coal to last 3,000 years!

Norfolk and Western Railway

CARRIER OF FUEL SATISFACTION

employees of concerns manufacturing and wholesaling materials.

The curriculum includes study of individual materials and their uses in construction, blueprint reading, estimating, site construction, purchasing, etc.

The courses have been approved by the Veterans' Administration for the training of veterans under the G.I. Bill of Rights. They call for 30 hours of classroom instruction per week, with field trips. Institutions giving the instruction

are: University of Illinois, Urbana, Ill.; Massachusetts State College, Amherst, Mass.; Michigan State College, East Lansing, Mich.; New York State College of Forestry, Syracuse University, Syracuse, N. Y.; Ohio State University, Columbus, Ohio; Purdue University, West Lafayette, Ind.; University of Washington, Seattle 5, Wash.; University of Wisconsin, Madison, Wis.; Southern Methodist University, Dallas, Tex.; Louisiana State University, Baton

Rouge, La.; Georgia Tech, Atlanta, Ga.; City College of New York, New York 19, N. Y.; and College of the Pacific, Stockton, Calif.

HOME DRIVE ON

A nation-wide drive to erect a large number of low- and moderate-priced rental housing projects for veterans was started on March 31 with the first of a series of meetings in which builders with outstanding records in rental construction will advise local home builders on the best methods of planning, financing and constructing rental projects. More than 100 local home building associations affiliated with the National Association of Home Builders are pledging support of the rental housing drive.

AWARDS ANNOUNCED

Results have been announced of the store design competition sponsored by the New York Chapter of the American Designers' Institute in cooperation with Garrison's Magazine: \$1000 first prize to Paul Canin, industrial design student at Pratt Institute; \$100 prizes to Anna Ruth Bonk, Paul Wrablich and Pamela Dohmer, George H. Fitzsimonds and Max C. Hanenstein, Harry David Gutmaker, Weston Anderson. The prize winning designs will be shown throughout the country.

GUIDE TO BUILDING

The Walker Art Center of Minneapolis is assembling material for a comprehensive Guide to Modern Building in the North Central States (Illinois, Iowa, Wisconsin, Minnesota, Nebraska, North and South Dakota). Publication is planned for 1948. Information on any modern building in the area — residential, industrial, commercial or civic — would be appreciated. Address William M. Friedman, Assistant Director, Walker Art Center, 1710 Lyndale Ave. S., Minneapolis 5, Minn.

OFFICE NOTES

Offices Opened, Reopened

Brother Cajetan J. B. Baumann, O.F.M., A.I.A., has opened an office doing architectural work for the Franciscan Order at 44 Whitehall St., New York 4, N. Y.

Richard E. Bishop, Architect and Planner, has opened an office at 401 Board of Trade Bldg., Indianapolis 4, Ind.

George J. Cavaliere, A.I.A., formerly chief architect, FHA, has resigned from government service to resume the general practice of architecture in association with Anthony M. DeRose, A.I.A., under the firm name of DeRose & Cavaliere, Architects. Address, 370 E. 119th St., New York 55, N. Y.

(Continued on page 166)

HOW TO MEET THE DEMAND FOR SEPARATE SHOWER BATHS

Surveys show more than half the families planning to build want separate shower baths.

You can meet this rapidly growing demand by specifying Weisway Cabinet Showers.

Precision-built, leakproof Weisways are made in models suitable for homes in every price class.



Weisway

CABINET SHOWERS

Product of the pioneer manufacturer in this field, Weisways offer a thoroughly satisfactory answer to the insistent demand for separate shower baths. Quality-proved and service-tested through years of actual use, Weisways insure the owner's satisfaction, protect your reputation . . . you specify Weisways with assurance. Write now for detailed information about Weisway features, including the vitreous porcelain receptor with exclusive "foot-grip, no-slip" floor.

HENRY WEIS MFG. CO., INC., 503 OAK ST., ELKHART, IND.

Q. What is the effective technique for insulating the narrow spaces around windows and air ducts?

A. See Balsam-Wool Application Data Sheet Section C, No. 1.

Q. What are the thermal resistance values of various building materials?

A. See Balsam-Wool Data Sheet Section A, No. 1.

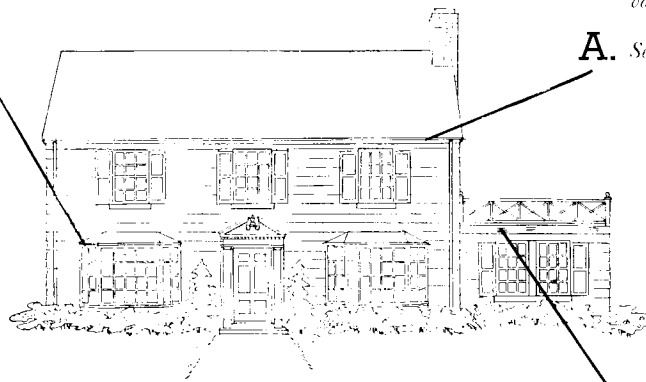

Q. What methods can be used to ventilate flat-roofed construction effectively?

A. See Balsam-Wool Data Sheet Section B, No. 5.

Quick Facts for Busy Architects . . . Balsam-Wool Data Sheets

Through its twenty-five years of experience, Wood Conversion Company has collected a wealth of valuable information on applying insulation. This information is embodied in a series of Balsam-Wool Application Data Sheets. These sheets are offered to you without cost or obligation. Mail the coupon for your set!

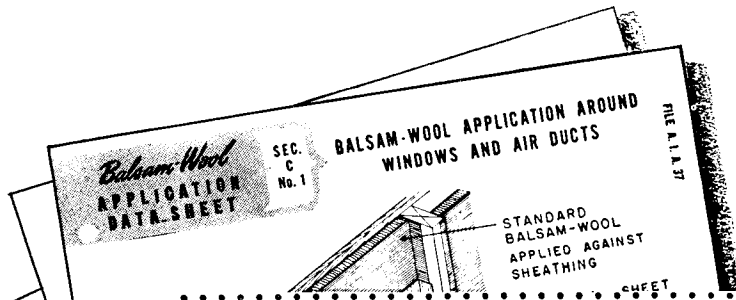

Balsam-Wool

SEALED INSULATION

BALSAM-WOOL • Products of Weyerhaeuser • NU-WOOD

VAPOR B
OVER SIX
WEIGHT
POCKET

Wood Conversion Company
Dept. 115-57 First National Bank Building
St. Paul 1, Minnesota

Please send me set of Balsam-Wool Application Data Sheets.

Name

Address

City State

FIBER
CLE

Ethelbert E. Furlong, Landscape Architect and Site Consultant, has reopened his office in the practice of land planning and site engineering at 93 Baldwin St., Glen Ridge, N. J.

Gordon Obrig Associates, Inc., 7 E. 48th St., New York 17, N. Y., have announced a complete design and detail service for commercial, industrial and home fields.

Leo H. Rich, associated with the Walter Dorwin Teague industrial design

firm from 1942 to 1946, has announced the organization of his own company, Leo H. Rich Incorporated, with offices at 1 Wall St., New York 5, N. Y. The new firm will offer business clients a three-point "package program" of correlated economic and marketing research, industrial design and public relations.

Zeb Rike, A.I.A., has announced the opening of an office for the practice of architecture in the Nelson Bldg., McAllen, Texas.

STEEL JOISTS AND STUDS YOU CAN NAIL INTO LIKE WOOD

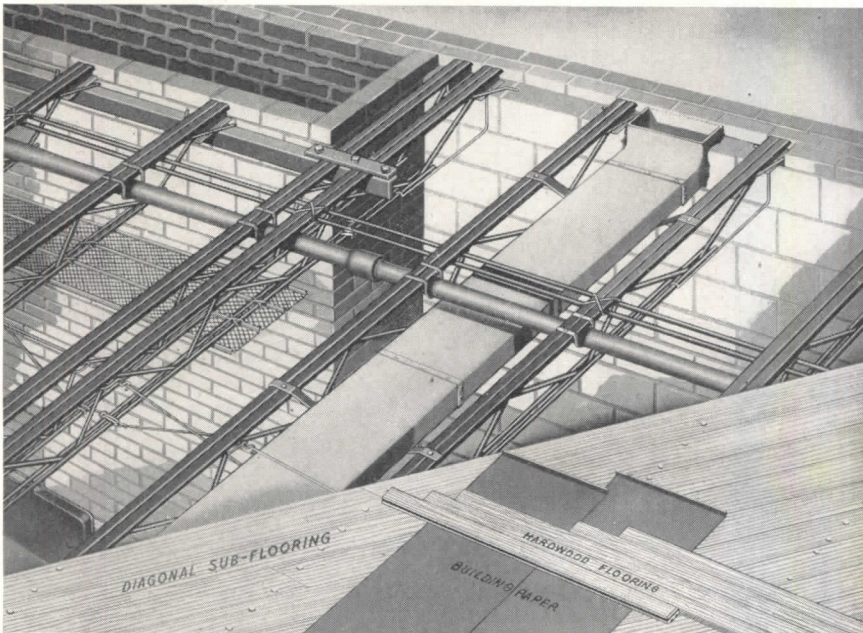

PATENTS PENDING

Builders everywhere have welcomed these improved steel sections. Adding NAILABILITY to the original Macomber Bar Joist now gives designers and builders one steel joist of universal application.

Shown above is the Macomber V-Type Bar Joist in a typical dwelling installation. Flooring is nailed directly to joists. More room is provided for pipe and duct work. Sizes are determined from standard Steel Joist Institute Loading Table. Made in Joist, Purlin and Stud sections.

Further information upon request. See our catalog in Sweet's 1947.



MACOMBER
CANTON • OHIO
MEMBER OF THE STEEL JOIST INSTITUTE

New Addresses

The following new addresses have been announced:

Jo Sinel, Design for Industry, 561 Clay St., San Francisco 11, Calif.

Lyle Swiger, Architect, 307 First National Bank Bldg., Newport News, Va.

Firm Changes

Walter Baermann, industrial designer, and Marc Peter, Jr., architect, have resigned from Norman Bel Geddes and Co. to form the new industrial design firm of Baermann and Peter. Address, 317 E. 51st St., New York 22, N. Y.

Joseph Norman Hettell has announced the formation of a partnership with Wm. Kendall Albert for the practice of architecture under the firm name of Joseph Norman Hettell and Wm. Kendall Albert, Architects, with offices at 501 Cooper St., Camden, N. J.

Sylvester Leroy Smith, Architect, and Judson F. Vogdes, Jr., Engineer, have taken offices for general practice at 315 Broad St. Station, Philadelphia 2, Penn. Mr. Smith has discontinued his office at 250 North 15th St.

ELECTIONS

New officers of the California Council of Architects are: *president*, Vincent Palmer; *vice president*, Andrew Hass; *secretary-treasurer*, A. C. Martin, Jr.

The Asphalt Tile Institute has announced the election of the following officers: *president*, H. Dorn Stewart, Armstrong Cork Co.; *vice president*, J. O. Heppes, The Tile-Tex Co.; *secretary-treasurer*, C. A. Neumann, David E. Kennedy, Inc.

The Westchester Chapter, A.I.A., has elected the following officers: *president*, Edward Fleagle; *vice president*, Oscar A. deBogdan; *secretary*, Lusby Simpson; *treasurer*, John M. Paul.

APPOINTMENT

Carroll J. Peirce, Jr., chief of aerodynamics for the Boeing Airplane Co., Wichita, Kansas, has been appointed director of the Ohio State University School of Aviation.

ADDENDUM

Otto Vogt should have been credited as structural engineer for the Valley Avenue Apartments, Berla & Abel, Architects, appearing in the March ARCHITECTURAL RECORD, pp. 100-101.

ERRATUM

In the article, "Comparative Costs in Apartment Heating" in the March RECORD the footnote on page 109 should have read: "The original 'Metro' system was developed for Parkchester Apartments, Bronx, N. Y.; installed under direction of Henry C. Meyer, Jr., of Meyer, Strong, and Jones, Inc.; patent held by Henry G. Schaefer."

TWO KINDS OF HEAT IN ONE GREAT MODERN BLEND!

- that's what Modine Convectors offer you!



RADIANT HEATING

Mild, radiant heat in just enough quantity to offset heat loss from window areas — that's what those arrows represent, coming from the Modine Convector Panel below the window. To this we add . . .



CONVECTION HEATING

Warmed air circulated by Convection Heating. Hot water or steam passes through copper heating unit which draws cooler, floor-line air into bottom of convector where it's warmed, rises and then passes out through grille.

Result: A modern, blended heating system for modern winter comfort — whether it's school, hospital, home or apartment! A heating system that gives you individual room control . . . gentle, draft-free air circulation without the use of moving parts that wear out! Yes, the dependable heating comfort, distinctive charm, space saving, cleanliness, and long service life of Modine Convector Radiation is recommended for all types of residential and institutional heating needs. Look for Modine's representative in the "Where to Buy it" section of your phone book. Write for complete information and free descriptive literature. MODINE MANUFACTURING CO., 1773 Racine St., Racine, Wis.

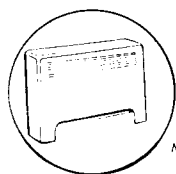

MODERN
BEAUTY

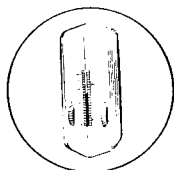

CLOSE TEMP-
ERATURE CONTROL



EASY TO
INSTALL

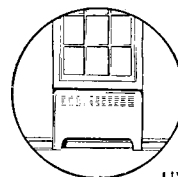

ADDS TO
LIVING SPACE

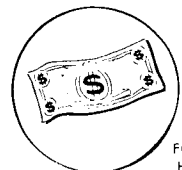

PRICED
FOR TODAY'S
HOMES AND
APARTMENTS

Modine
CONVECTOR RADIATION
The Modern "proved by use" heating method

(Continued from page 147)

SLIDING DOOR UNIT

A new type of sliding door unit, known as the *Glidaway*, works without rollers and is designed for 4-in. walls and for both single- and double-pocket openings. Any design of door, either flush or paneled, may be adapted to the frame provided thickness is not more than 1 3/8 in. Frames are available in a range of stock sizes to fit various door widths and heights. U. S. Plywood Corp., 55 W. 44th St., New York 18, N. Y.

PLASTICS

The New York sales-engineering and executive offices of Bakelite Corporation have been remodeled to show to best advantage the many uses of Bakelite and Vinylite plastics for room interiors. Throughout the offices these plastics appear in the form of decorative laminates with wood veneer surfacings, resin-bonded plywood, molded floor tiles, resin-fortified wood lacquers, flexible film and sheeting for draperies, and

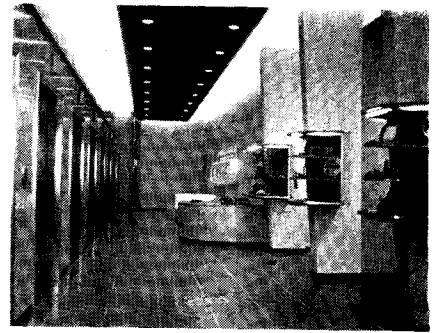

Plastics featured in remodeled offices

resin-coated fabrics for chair and wall coverings. The rooms, designed by Walter Dorwin Teague, consist of a display lobby, conference rooms, and a number of offices, each stressing the different color combinations and varying treatment possible with these plastics, which reportedly offer advantages of enduring finish, resistance to water and wear, and fire resistance. Bakelite Corp., 300 Madison Ave., New York 17, N. Y.

UNIT HEATERS

Electric unit heaters are used to carry the entire heating load at a large flour mill in Chattanooga, Tenn., where power rates are comparatively low. The mill is heated 24 hours a day, seven days a week, during the winter months. Located strategically throughout the plant are 50 *Electromode* heaters ranging in capacity from 7.5 to 20 kw. and equipped with thermostatic controls. The connected load for the mill's 598,650 cu. ft. is 655.5 kw. Complete protection against fire and explosion hazards is claimed because of the patented enclosed construction of the heating element. There are no exposed glowing wires since the resistor is insulated and encased in a tubular sheath, which in turn is embedded in a one-piece finned aluminum casting. Electromode Corp., 45 Crouch St., Rochester 3, N. Y.

ROOF VENTILATOR

A new attic or under-roof space ventilator is designed for hip or 4-sided roofs. It is all-steel and welded into the shape of a graceful curve. Lower part of the ventilator opening is equipped with a baffle to exclude weather, and the 36-in. free area is covered with an insect screen. Integral flashing is said to permit weather-tight installation. The Swartwout Co., Cleveland, Ohio.

ALUMINUM WINDOW

The *Winco Ventilating Window* can be opened in the conventional way by raising the sash, or it can be placed in the ventilating position by tilting the lower section inward like a transom. A metal

(Continued on page 170)

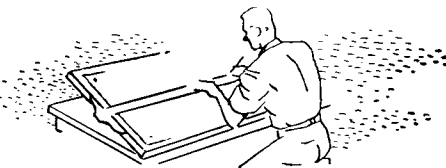

Beautiful kitchen in the home of George Leikert, Detroit, Michigan, illustrates the modern beauty and utility of Marlite panels and Marsh mouldings.

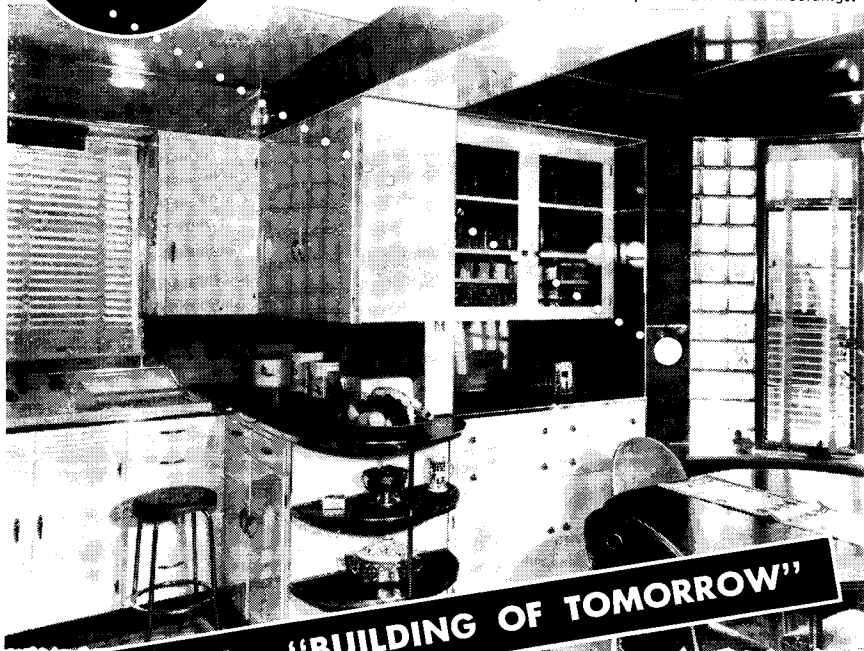

Appealing beauty and economical utility are characteristics of the "Building of Tomorrow," designed for better living.

Versatile Marlite plastic-finished wall and ceiling panels, adaptable to every type of construction, provide colorful interiors that are at once pleasing and serviceable. Marlite seals in beauty, seals out dirt and grime, is quickly installed, easy to keep clean. Plan now to make the most of Marlite, designed for the "Building of Tomorrow." Marsh Wall Products, Inc., 505 Main Street, Dover, Ohio.

*For Creating
Beautiful Interiors*



Marlite
REG. U. S. PAT. OFF.
PLASTIC-FINISHED
WALL PANELS

STAINLESS STEEL



and now -
SCREENS

Another outside job has been taken over by the metal that has given permanent beauty to everything from kitchen sinks to building trim. Home owners are installing stainless steel screens for their windows, doors, and porches. They've found that the stainless-steel screens do not stain any painted surface beneath them, though many times soaked by rain. And they resist denting and tearing, too. If you would like to keep informed about the many other uses for stainless steel in the home, ask to receive our monthly publication ELECTROMET REVIEW. Write to Department A-5.

ELECTRO METALLURGICAL COMPANY

Unit of Union Carbide and Carbon Corporation
30 East 42nd Street  New York 17, N. Y.

PRODUCERS OF ALLOYS THAT MAKE STEEL STAINLESS

Beautiful Enduring Strong Tough

(Continued from page 168)

screen, hinged to swing outward, is provided, and can be interchanged with an aluminum storm sash. The window frame and sash are made entirely of aluminum, and weigh 14 lb. Finish is etched and coated with clear lacquer. The window comes as a packaged unit, complete with brick stops, necessary hardware, locks and lifts, weather-stripping, stainless steel wings, and glass in the lower sash set in a rubber extrusion. Watco Engineering Inc., Cleveland 13.

CABINET INSERTS

The *Dual Purpose Shelf* is a slotted insert for medicine cabinets, designed for compact storage of toilet articles, shaving equipment, and other items that customarily clutter bathroom shelves. Inserts are installed by adjusting for shelf width and sliding within the cabinets where they are held in place by rubber cushion ends. The Modernwise Cabinet Co., 5404 Fourth St., N. W., Washington 11, D. C.

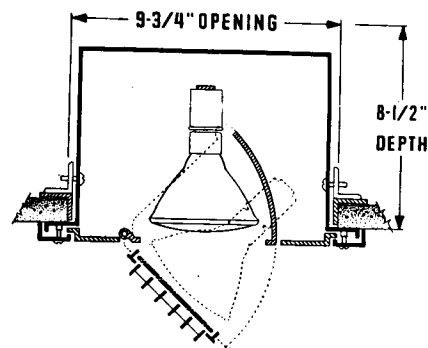

Lamp housing permits directed lighting

DIRECTED LIGHTING

Rotobeam, a touch-directed lighting aid, is designed to afford new freedom in display lighting. A PAR spot or floodlight is provided in an adjustable housing of cast aluminum and steel for recessed installation in walls, ceilings, or floors. Direction of the beam can be changed by rotating the disc and by tilting the housing on its concealed pivot hinge at any angle up to 45°. General Lighting Co., 32 Union Square, New York 3, N. Y.

DAMPPROOFING

Recently announced was *Barriercoat*, a new moisture-, vapor-, and corrosion-resistant coating for wood, metal, and concrete. It has a bituminous gum base carried in a petroleum solvent, and is applied by brushing, spraying, or troweling. No heating is required. After application, the solvent evaporates, leaving a resilient base coating. *Barriercoat* is usually supplied in black, but may also be obtained in maroon, green, or aluminum color. Carbozite Protective Coatings, Inc., Greensburg, Penn.

ALUMINUM BUILDING PRODUCTS

Reflective insulation is said to be provided to a high degree by aluminum siding and shingles. Clapboard siding is available in 12-ft. lengths, either plain or textured, and weighs about 5 lb. The siding is .032 in. thick, formed with a butt thickness of 13/16 in., which gives a heavy shadow line. Accessories are starter strip, butt joint, outside corner caps, and inside and outside corner posts. The aluminum shingles are designed to provide an air space between their under surface and the sheathing for better insulation; and their sides interlock to provide a weathertight seal. There are no exposed nails. The bungalow-size shingle measures 5 1/2 by 18 1/2 in.; the master-size, 8 by 14 1/2 in. Both shingles and siding may be painted if desired. Reynolds Metal Co., Building Products Div., Louisville 1, Ky.

(Continued on page 172)

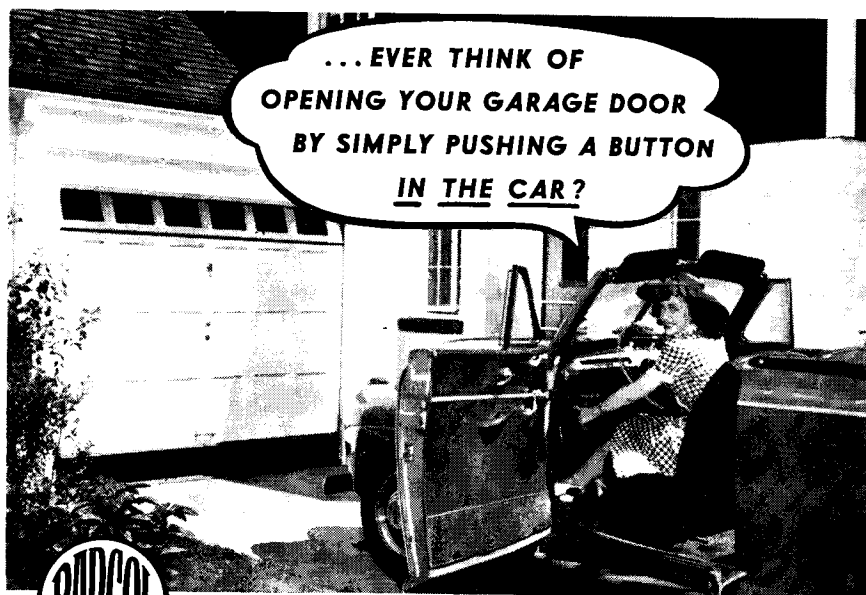

BARBER-COLMAN RADIO CONTROL for GARAGE DOOR OPERATORS

The elegant Mrs. Giltrox has a button to buzz for her butler, and the wealthy Mr. Giltrox has a battery of them for his staff of glamorous secretaries — but here is a button that plain Mrs. Bill Jones (and thousands of other Mrs. Joneses and Smiths and Browns) can have. It will bring these charming, hard-working, family-raising folks a sensational service and convenience — and at surprising low cost. It is the button in their car that they push to open the garage doors!

TIME-PROVED — DEPENDABLE

Barber-Colman developed the original model of the Radio Control for Garage Doors over twenty years ago. Through an important period of redesign, simplification, and improvement, the current Model C was evolved and introduced about ten years ago. Hundreds of satisfactory installations have been made, and further refinements

added from time to time. Today you can buy this reliable, time-proved, trouble-free unit and count on it to perform properly and accurately for you through many years of satisfactory service.

UNDIVIDED RESPONSIBILITY — SINGLE SOURCE FOR DOORS AND OPERATORS

Another important feature — Barber-Colman makes not only the Radio Control, but also the doors (Barcol OVERdoors) and the Electric Door Operators. So, when planning a garage installation, you can get all the necessary elements from a single source. This means that one well-established firm will assume responsibility for proper construction, installation, operation, and service — a vital factor in the solution of today's home-building problems.

See our Catalog in Sweet's.

FACTORY-TRAINED SALES and SERVICE REPRESENTATIVES IN PRINCIPAL CITIES

BARBER-COLMAN COMPANY

102 MILL ST. • ROCKFORD, ILL.

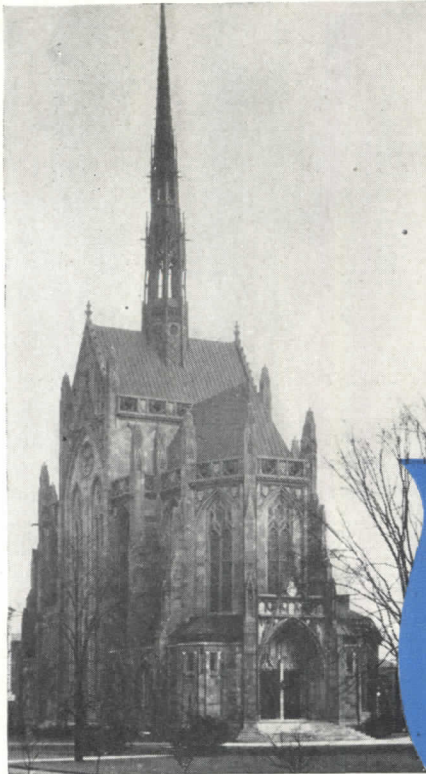

Heinz Memorial Chapel

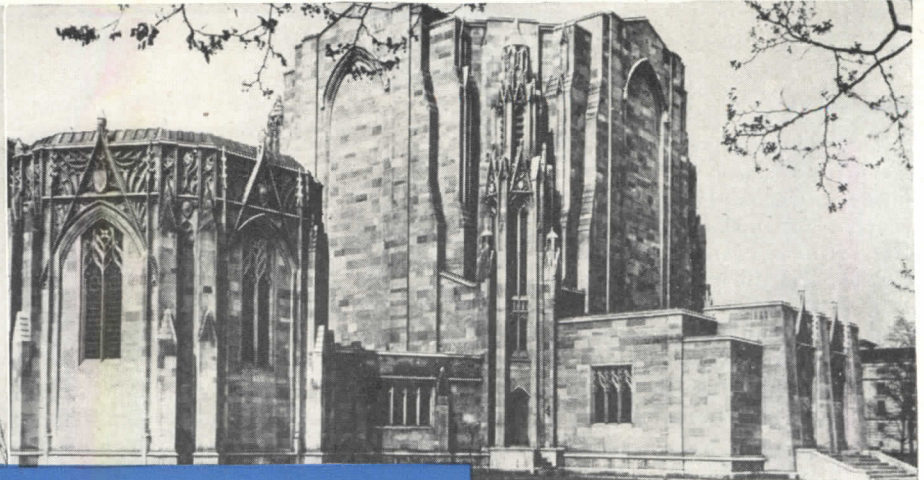

Stephen Foster Memorial

HANDSOME IS
as
HANDSOME DOES



Mellon Institute



Cathedral of Learning

District Heating simplifies building design, provides more usable space at lower operating and maintenance costs

No ugly stacks mar the beauty of this group of buildings at the University of Pittsburgh. Unhampered by the necessity of allotting space for heating units, fuel delivery and storage, and ash removal, designers enjoyed full freedom of line for beauty, while providing maximum utility for every foot of space in these fully functional structures.

District heating made it possible. Distribution is currently being extended to include a large

group of hospital buildings. The system also effects savings in fuel consumption, reduction in required maintenance personnel, and greater protection from fire and explosion. Because it eliminates the production of smoke and soot in the area, cleanliness and lasting beauty are assured for every building in the group.

In this instance, as in hundreds of other major central heating systems, Ric-wil conduit provides efficient, economical heat distribution.

RIC-WIL INSULATED PIPE CONDUIT SYSTEMS
THE RIC-WIL COMPANY • CLEVELAND, OHIO

AGENTS IN PRINCIPAL CITIES

(Continued from page 170)

PANEL SYSTEM

The patented system of *Thermo-Namel* porcelain enameled steel panels filled with *Thermo-Con* expanded cellular concrete, originally developed for the Higgins prefabricated house, can soon be employed in other house construction. Under the marketing scheme under study, an architect can design a house and through the contractor order *Thermo-Namel* panels from the Higgins dealer in his community. When the

interior and exterior panels have been set in place upon the foundations, *Thermo-Con* is then poured between, where it expands and hardens to form a monolithic structure. Higgins, Inc., New Orleans, La.

CONVECTORS AND RADIATORS

Magna-Fin convectors and radiators, though comparatively light in weight, are designed for heavy duty performance, operating on steam or hot water.

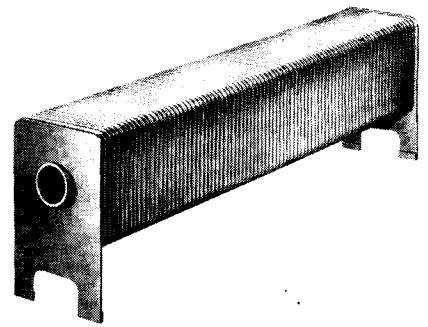

Finned radiator conserves floor space

The convectors are made of either steel or copper tubing with steel or aluminum fins tightly secured to the tube without solder or brazing. Steel fins are .036 in. thick and aluminum fins, .032 in. The tube wall reportedly will withstand pressures up to 200 lb. Convector units are furnished in six standard lengths: 2, 4, 6, 8, 10, and 12 ft. The radiator is of all-steel construction and features high-heating capacity, light weight, and compactness. Fins are fabricated of heavy-gauge steel, .048 in. thick. Space requirements are small: a radiator of 30 E.D.R. capacity is 8 in. high, 5 1/8 in. wide, and 54 3/4 in. long. Radiators are manufactured for 5 capacities: 10, 13, 17, 20, and 30 E.D.R. The Rittling Corp., 1292-1298 Niagara St., Buffalo 13, N. Y.

STEEL WINDOWS

Two new types of steel windows are now being manufactured for commercial and general utility buildings. The utility window, 3 ft. 6 5/8 in. high and 2 ft. 8 7/8 in. wide, is constructed with a horizontal top section that opens inward. A spring-locking device with a wire-pull rail attachment is said to simplify its opening and insure weather-tight closing. The commercial projected steel window has a ventilator section that swings outward from the bottom and downward from the top. The absence of projections into the building allows free passage next to the windows. When installed in tandem, a mullion, 3 in. wide, provides positive anchorage without sacrificing light. The window is available in six sizes. Copeo Steel and Engineering Co., 11035 Grand River Ave., Detroit 27, Mich.

FLUORESCENT HOLDERS

Recently announced are improvements in fluorescent lampholder design to eliminate the danger of cracked sockets, faulty contact, and falling lamps. A spring-action plug holds the lamp so that it cannot be released without the application of pressure; guides prevent the incorrect insertion of lamps and breakage of sockets; and new

(Continued on page 171)

IMPLEMENT OF ARCHITECTURE



All the natural beauty of the solid metals of Schlage Locks is brought forth by Schlage's carefully controlled finishing techniques. Since Schlage brass, bronze and aluminum finishes are part of the base metals (not plated), durability is assured. There are many finishes from which to choose, including Schlage's exclusive aluminum "Luster-Sealed" finish which retains its satin silver appearance indefinitely without tarnishing.

SCHLAGE

LOCK COMPANY

SAN FRANCISCO • NEW YORK

ORIGINATORS OF THE CYLINDRICAL LOCK

FREE! This 96-page book...

to celebrate
our 50TH ANNIVERSARY
1897-1947



We have printed a special anniversary edition of this invaluable book for business executives, architects, contractors and engineers. This 96-page book summarizes our unique and extensive experience in the protection and decoration of structures after 50 years of manufacture and service. In that time we have faced and solved many problems on thousands of projects, involving every industry, every variation in climate and almost every known condition.

CONTENTS

HOW TO SOLVE MANY CONSTRUCTION
AND MAINTENANCE PROBLEMS

- ➔ CONSTRUCTION DETAILS
- ➔ MATERIAL TABLES
- ➔ WEIGHTS AND MEASURES
- ➔ HORN PRODUCTS AND METHODS

Here is a book giving you engineering data and specifications to help you solve many problems of waterproofing, dampproofing, painting, caulking, roofing and flooring. You may have this reference book with our compliments. Naturally, the edition is limited, first requested, first served. Write today—

WRITE ON YOUR BUSINESS LETTERHEAD

A. C. HORN COMPANY, INC.
43-35 Tenth Street
Long Island City 1, New York

(Continued from page 172)

design reportedly makes it impossible to insert lamp without positive contact — if the lamp does not make contact it will not stay in the socket. Allied Electric Products, Inc., 76-82 Coit St., Irvington 11, N. J.

SASH BALANCE

The *Hidalift* balance for double-hung sash is of metal construction and operates on spring tension, thus eliminating weight boxes and gaining about 4 in. in window width. Constant tension gives the sash a "lift," making it easier to raise heavy windows. All parts are rustproofed and the spring is sealed in tubing to prevent wear caused by dust. Standard size is Type No. 58, which will carry sash as heavy as 30 lb. Balances for special and odd-size sash can also be obtained. Turner & Seymour Mfg. Co., Torrington, Conn.

ELECTRIC WATER HEATERS

Table-Top Model

A new electric water heater measures only 24 by 24 in. and is the height of a table so that it may serve double duty in kitchens by providing an additional work surface of porcelain enamel. Features include thermostatic control, with an adjustment range of 120° to 170° F., an immersion-type electric heating element, Fiberglas insulation, and a cold-water baffle. The tank is of galvanized copper-bearing steel, and has a 40-gal. capacity. Electric Appliance Div., Westinghouse Electric Corp., Mansfield, Ohio.

"Heat-Wrap" Tank

Tank walls are used to conduct heat to the water in a redesigned line of electric water heaters. Heating unit consists of "Heat-Wrap Calrod" in ribbons that encircle the tank and are held tight against its surface by stainless steel channels. Advantages are said to be increased heat efficiency and the elimination of corrosion of the heating element. The following capacities are announced: with galvanized tanks, 15-, 30-, 40-, 52-, 66-, and 82-gal.; with Monel tanks, 30-, 40-, 50-, and 80-gal. All heaters are round with the exception of the 30-gal. rectangular table-top model. Also announced was a means of providing magnesium protection for galvanized tanks in corrosive-water areas. A special magnesium-alloy tube can be installed in the tank, which sets up an electrolytic action and in time coats the wall with a protective magnesium coating. Appliance and Merchandise Dept., General Electric Co., Boston Ave., Bridgeport 2, Conn.

(Continued on page 176)

Vapor Condensation



**but RUINOUS
WITHIN WALLS**

When moisture vapor "steams up" windows it does no harm, but if it condenses within building walls it can be a four-way evil. Yes, "in-wall" condensation can make insulation soggy and inefficient, cause wall stains, paint peeling — even structure rot. One sure way to beat this building bugaboo is with a *separate* vapor barrier. Standard with architects everywhere is Bird Neponset Black Vapor Barrier. Applied on the warm side of insulation, Bird Neponset Black repels vapor, keeps insulation at peak efficiency, ends all other "in-wall" condensation evils. Only about \$20 buys life-long protection for a \$10,000 building. Specify the standard — Bird Neponset Black Vapor Barrier. See Sweet's Architectural file, 9b-2, or write for sample to Bird & Son, inc., 176 Wash. St., East Walpole, Mass.

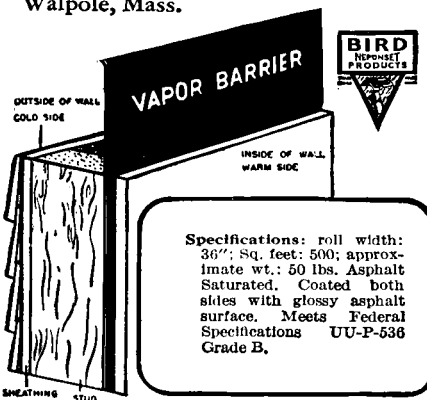

Specifications: roll width: 36"; Sq. feet: 500; approximate wt.: 50 lbs. Asphalt Saturated. Coated both sides with glossy asphalt surface. Meets Federal Specifications UU-P-536 Grade B.

**BIRD NEPONSET BLACK
VAPOR BARRIER**

BIRD & SON inc., E. WALPOLE, MASS.
CHICAGO NEW YORK SHREVEPORT

**KEEP THOSE
CONCRETE
EXPANSION
JOINTS
SEALED
ALL YEAR 'ROUND!**

SPECIFY

THE ORIGINAL
Para-Plastic
REG. U. S. PAT. OFF.
HOT-POURED RUBBERIZED SEAL

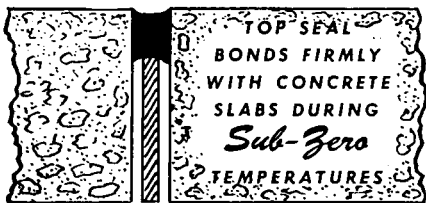

TOP SEAL
BONDS FIRMLY
WITH CONCRETE
SLABS DURING
Sub-Zero
TEMPERATURES

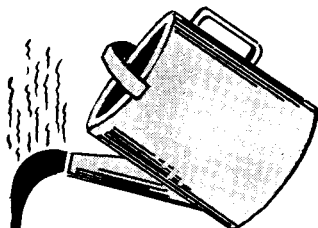

PARA-PLASTIC is the ORIGINAL hot-poured rubber seal for concrete expansion joints.

PARA-PLASTIC remains flexible all year 'round. Its elasticity is permanent in any temperature without breaking its bond with concrete.

PARA-PLASTIC is the positive and permanent top seal for concrete expansion joints all year 'round against the infiltration of water.

Write for further technical information

**"STICK" WITH THE
ORIGINAL
ALL YEAR 'ROUND**



See Our Catalog in Sweet's

SERVICED PRODUCTS CORP.
6051 West 65th Street. Chicago 38, Ill.

FOR REALLY FINE UPHOLSTERY

Duran

ALL PLASTIC



Duran is the new all-plastic covering for fine upholstery effects in homes, hotels, clubs and restaurants. Duran is all-plastic, not a fabric, consequently will not chip or peel. On walls, panelling, booths, stools and loges its colorful beauty provides the fitting touch to your finest planning. Resistant to water, grease, alcohol, perspiration, scuffing, fading, Duran cleans easily with soap and water. National advertising is now telling your clients about Duran. Write today for full information.

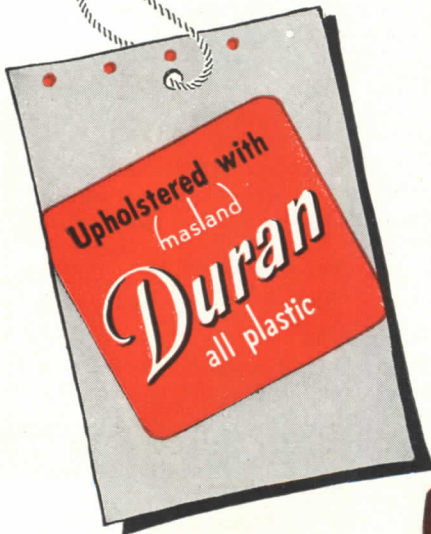

masland

THE MASLAND DURALEATHER COMPANY, 3236-3290 Amber St., Philadelphia 34, Pa.



Photographs of Duran upholstered furniture are shown by courtesy of Wisconsin Chair Co., Port Washington, Wis.

(Continued from page 174)

**NOW!
Immediate
Delivery**

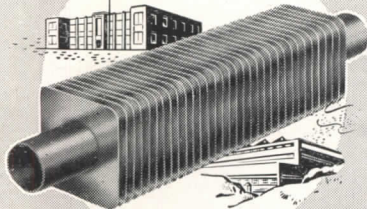

**MAGNA Fin
CONVECTORS
AND
RADIATORS**

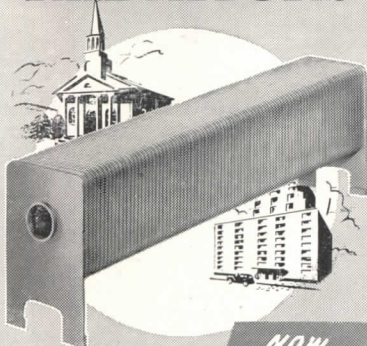

**MORE HEAT..
QUICKER HEAT..
BETTER HEAT...**

in less space

**NOW
IT CAN BE
SOLD**

- Heavy duty, lightweight units for comfort or thermal processes, withstands up to 200 lbs. pressure.
- Exceptionally high heating and radiation capacities, compacted into small space.
- 1 1/4" copper tube with aluminum fins. Also in 1 1/4"-2" steel pipe with steel fin surfaces.

At Leading Heating Supply Jobbers or Write for Catalogue MF A and Price Lists.

Also manufacturers of propeller fan unit heaters in horizontal or down-blow types.

Some Choice Territories Still Available

Kittling CORP.

1292-1298 NIAGARA ST. BUFFALO 13, N. Y.

PRINTER DEVELOPER

The Model 91 BW *Volumatic Printer-Developer* is designed for large-volume production of cut sheets, and accommodates roll stock up to 42 in. in width. It prints and develops all Bruning BW media: light, regular, or card-weight BW paper prints with black or colored lines on white backgrounds, black or colored line paper prints on green-tinted backgrounds; transparent paper prints; and cloth or film prints. Prints are produced in volume at speeds up to 30 ft. per min. The following operating improvements were announced: new enlarged feed board, simplified control, increased light efficiency, and improved developing technique. Charles Bruning Co., Inc., 4754 Montrose Ave., Chicago 41, Ill.

SHOWER CONTROL VALVE

The danger of scalding and discomfort of chilling in shower baths, due to sudden pressure drops, is reportedly eliminated when an *Aquatemp Control Valve* is installed in the shower fitting. The valve is pressure-operated, and is said to be adaptable to any type of fitting. Milton-Griffith Co., 8619 Mack Ave., Detroit 14, Mich.

STANDARDS

Convectors

A new commercial standard, CS140-47, on "Testing and Rating Convectors," is now in effect, after acceptance by a majority of representative user organizations, testing laboratories, government agencies, distributors, and manufacturers. This standard covers definitions, requirements, and methods of testing and rating cast iron and non-ferrous steam and hot water convectors; also means of guaranteeing compliance with the standard, and checking convector ratings for approval. National Bureau of Standards, Dept. of Commerce, Washington 25, D. C.

Wire Screens

A minimum commercial standard for insect wire screening is now being distributed to hardware and building supply dealers. Three mesh sizes — 16 by 16, 18 by 14, and 18 by 18 — may be labeled as standard under Commercial Standard CS138-47, which was voluntarily adopted by the industry and promulgated by the National Bureau of Standards. The standard metals are galvanized steel, and commercial bronze and copper. Wire thickness is specified as .011 in. Insect Wire Screening Bureau, 74 Trinity Pl., New York 6, N. Y.

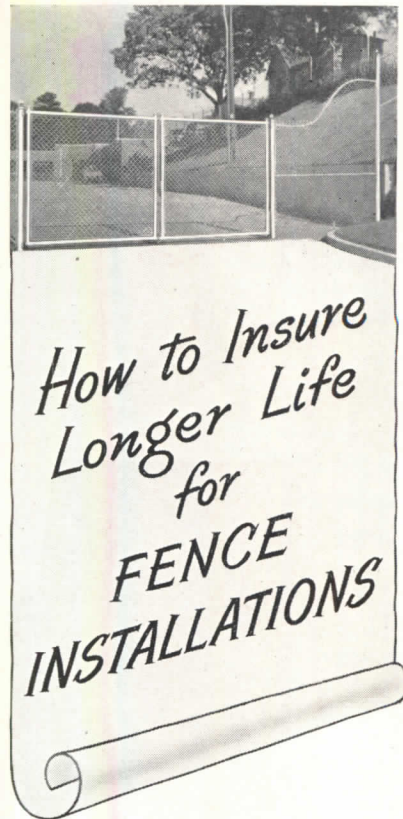

Specifying Anchor Chain Link Fence is the answer! It can't be beaten for rugged construction and exclusive design that means extra years of maximum protection. And there are four big reasons for this performance:

1. *Deep-Driven Anchors* hold the fence permanently erect and in line, in any soil or weather, yet permit easy relocation where necessary.
2. *Square Frame Gates* remain free from warping and sagging.
3. *U-Bar Line Posts* are rust-free, rigid and self-draining.
4. *Square Terminal Posts* improve strength, durability and appearance.

**Get This Book for
A. I. A. File 14-K**

"Anchor Protective Fences" is both a catalog and a specification manual. Shows many types and uses of Anchor Chain Link Fence . . . pictures installations for many prominent companies and institutions . . . contains structural diagrams and specification tables. Just ask for Book No. 110. You'll find it both useful and informative. We'll be glad to send you a free copy. Address: ANCHOR POST FENCE DIVISION, Anchor Post Products, Inc., 6600 Eastern Ave., Baltimore 24, Maryland.

Anchor Fence
Nation-wide Sales and Erecting Service

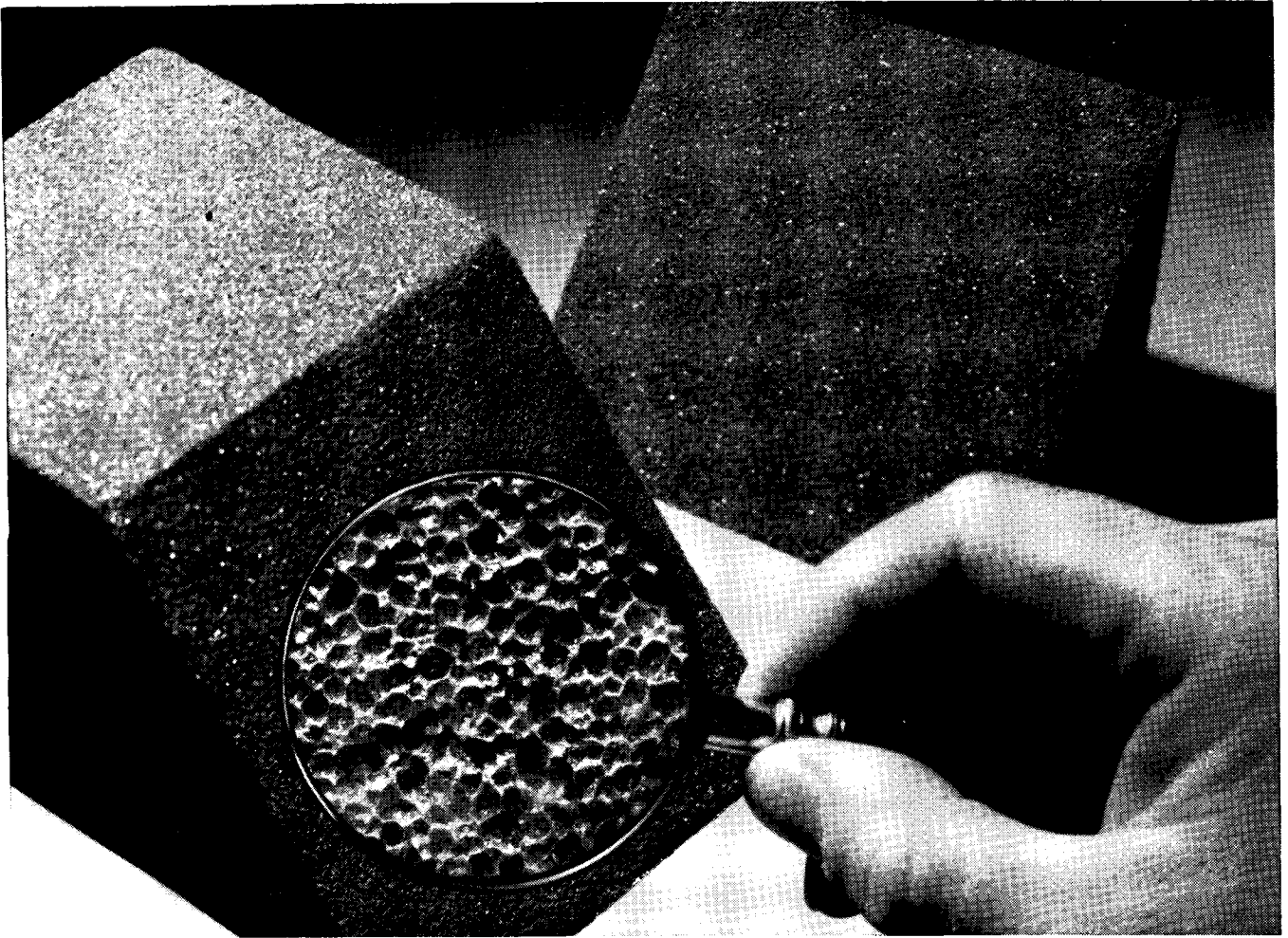

HERE'S THE SECRET OF Permanent Insulation



● Look at the picture for a minute. You can see that PC Foamglas is composed of tiny glass cells . . . millions of them. And these cells are filled with sealed-in air.

Used as an insulating material on roofs and in walls and floors, PC Foamglas helps to maintain desired temperature levels and to minimize condensation. Because it is glass—and therefore waterproof, verminproof and fireproof—it also has the unique advantage of retaining its insulating value *permanently*.

When you are figuring insulation, our engineers will be glad to help you decide on the *proper thickness* of PC Foamglas to give you efficient, permanent insulation. Meanwhile, send the coupon for your selection of our helpful, informative free booklets. Pittsburgh Corning Corporation, 632 Duquesne Way, Pittsburgh 22, Pa.

· Also Makers of PC Glass Blocks ·

Pittsburgh Corning Corporation
Room 436, 632 Duquesne Way
Pittsburgh 22, Pa.

Please send me without obligation,
your free booklets on the use of PC
Foamglas insulation for:

Roofs..... Walls..... Floors.....

Name.....

Address.....

City..... State.....

PC FOAMGLAS *Waterproof* *Fireproof* **INSULATION**
T. M. REG. U. S. PAT. OFF.

FOR ADDITIONAL INFORMATION SEE OUR INSERTS IN SWEET'S CATALOGS.

(Continued from page 154)

**Celebrating a
Centennial of Service**



THE PENN MUTUAL LIFE INSURANCE CO. Home Office, Philadelphia, Pa. 10-story building at right built 1914. 20-story addition built 1933.

This is a year of celebration at Penn Mutual—their 100th year of satisfactory service to thousands of policy-owners. It also represents the 40th year of satisfactory service by Webster Steam Heating Equipment in Penn Mutual buildings.

Webster Equipment was first used by Penn Mutual in 1907. In 1933 the present home was completed with a 20-story addition, and equipped with a Webster Vacuum Heating System.

In 1941, a 6-zone Webster Moderator System was installed.

“Our records show a 10 per cent reduction in oil consumption with the Webster Moderator System,” says LeRoy E. Varner, Company Engineer. “All sections of the building heat evenly and rapidly.”

Much of the success of the Penn Mutual heating installation has resulted from the effective cooperation of the building management and the Webster Philadelphia Representative. The materials and service that produced these results for Penn Mutual are available now to help you obtain similar results in your building.

WARREN WEBSTER & CO., Camden, N. J. Representatives in principal U. S. Cities : : Est. 1888 In Canada: Darling Brothers, Limited, Montreal

Webster
HEATING SYSTEMS

of design features. Dimensions, chart selections, typical uses. 20 pp., illus. The Brown Instrument Co., Wayne & Roberts Aves., Philadelphia 44, Penn.

VENTILATORS

Presenting Winco Ventilators and Fans for Glass Block Walls and Windows. Sizes, specifications, installation procedure, typical applications. Ventilators are complete, ready to be built in, and equipped to carry glass block without angle iron, etc. Suggestions for height installations in bathrooms, kitchens and bedrooms. Vertical and horizontal sections. 6 pp., illus. Winco Ventilator Co., Inc., 1431 Veronica, St. Louis 15, Mo.

WOOD PRESERVATIVE

Protection of Wood by Chemical Treatment. Bulletin on four wood treating solutions, available in ready-to-use and in concentrate forms, for protection against mold, mildew, decay, termites, lyctus beetles, shrinking, warping, grain raising, checking and sapstain. All four solutions — Woodtox, Timbertox, Woodfix and Terratox — are oil preservatives which do not necessitate drying of lumber after treatment. Bulletin gives details of wood treating procedures, properties and characteristics of each of the products. 4 pp., illus. Wood Treating Chemicals Co., 5137 Southwest Ave., St. Louis 10, Mo.*

LITERATURE REQUESTED

The following individuals and firms request manufacturers' literature:

Max Flatow, Architect, P.O. Box 1539, Sante Fe, New Mexico.

Andrew R. Fritz, Architect, Room No. 1, 189 Sunrise Highway, Rockville Centre, N. Y.

Arthur W. Heine, Industrial Engineer, 1425 S. 11th St., Terre Haute, Ind.

Marshall Hurst, Architectural Drafting Dept., Miami Edison Senior High School, 6101 N. W. Z Ave., Miami 38, Fla.

Ellis L. Lavine, Architectural Engineer, 132 Nassau St., New York 7, N. Y.

Sidney K. Neill, Architect, 19 Bank Lane, Nassau, Bahamas.

Southeastern Engineering and Construction Co., 4 Allendale Rd., Montgomery, Ala.

Oren Thomas Associates, Architects, 726 Cooper St., Camden, N. J.

Weich and Bingham, Architects and Engineers, 303-304 American Trust Bldg., Middletown, Ohio.

The
RESTORATION
of
COLONIAL WILLIAMSBURG

*A Reprint
of the December, 1935
Issue of*

ARCHITECTURAL RECORD

*104 pages, bound in cloth
\$2.00 per copy*

The Colonial Williamsburg Number of ARCHITECTURAL RECORD — issue of December 1935 — was sold out soon after publication but the entire editorial contents have been reprinted and bound in permanent book form with blue cloth covers.

Many thousands of these Williamsburg reprints have been sold but the demand continues unabated.

ARCHITECTURAL RECORD

119 W. 40th Street, New York, N. Y.

Enclosed is \$.....for which send..... copies of your reprint, *The Restoration of Colonial Williamsburg*, bound in cloth, at \$2.00 per copy.

Name

Address

City and StateA.R. 5-47

"First with the Finest"

ARKETEX

CERAMIC GLAZED STRUCTURAL TILE



FOR VERSATILITY

The best laid plans of practical architects and builders include Arketex Ceramic Glazed Structural Tile because Arketex is versatile!

For cafeterias, hospitals, bakeries, locker plants . . . installations requiring gleaming, sanitary interior and exterior walls . . . Arketex is the practical choice.

For homes, apartments, schools, theaters . . . installations requiring lustrous walls combining permanency with beauty and economy . . . Arketex meets every high standard.

Designed to withstand hard usage yet retain its original freshness and pleasing beauty forever, Arketex Ceramic Glazed Structural Tile requires no periodic painting or refinishing—only infrequent soap and water cleaning is necessary to preserve its gleaming luster.

Arketex is a permanent wall and finish all in one—the first cost is the only cost. It will not crack, craze, scar or mar. When planning new construction or remodeling—

Always specify Arketex—*first with the finest!*
Write for Catalog S-45A.



ARKETEX CERAMIC CORPORATION • BRAZIL, INDIANA

take a

Tip

**ON CONDUIT
from the men
who install it**

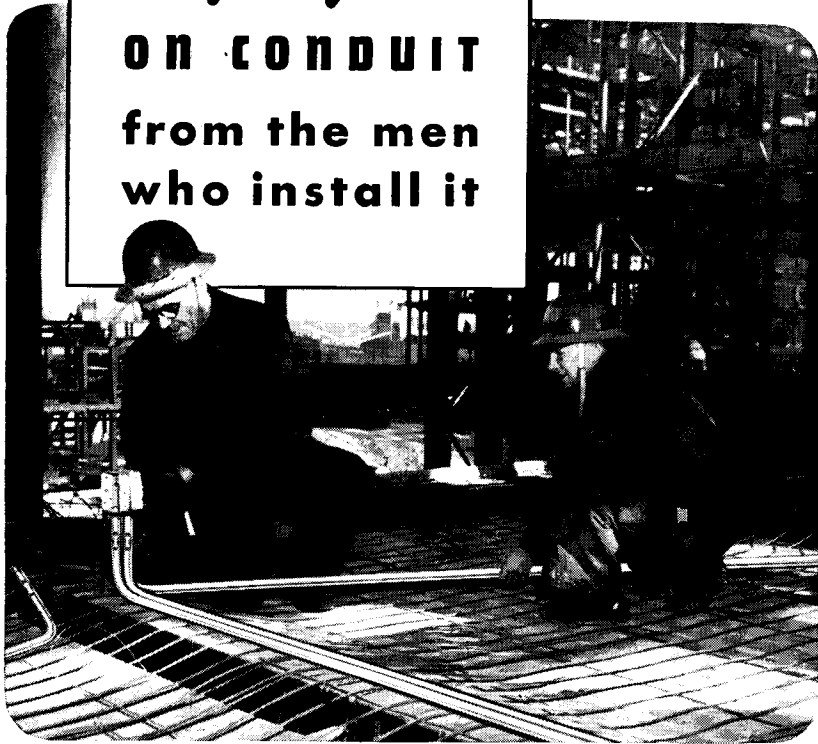

 **WHITE IS EASY TO HANDLE ON ANY JOB**

Men who work with General Electric White rigid conduit *like* the way it handles. They're sold on it because of its true threading, its even cutting, and its smooth interior surface, which makes wire-pulling easy. Advantages like these mean that G-E White helps put jobs in fast, makes raceways smooth, secure, permanent. Take a tip from the men who install it—specify G-E White for protection to wiring and for construction speed.

AND  WHITE GOES IN TO STAY

When you specify General Electric White, you can count on it to stay in service. Its *hot-dipped* zinc coating—inside and out—and its hard, smooth Glyptal* lacquer finish resist the attacks of atmospheric corrosion.

For details on our complete raceways line, write Section C54-55, Appliance and Merchandise Department, General Electric Company, Bridgeport 2, Connecticut.

*Trade-mark Reg. U.S. Pat. Off.

GENERAL  ELECTRIC

RACEWAYS ROUND-UP

with your



Merchandise Distributor

Look to General Electric for everything you need for conduit installa-



tions. The complete line includes locknuts, bushings, connectors, wedges, reducers, enlargers, caps, ells,

straps, boxes—practically all the accessories necessary to wiring safety and convenience. Try the new, exclusively General Electric, S-shaped bar hangers, too. They are adaptable to any stud spacing, and are easily and quickly installed.

The electrical flexibility of buildings equipped with General Electric Q-

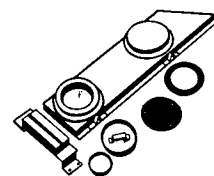

Floor wiring is assured, since every cell of the flooring can be used for electrical raceways as needed. Outlets

which can be placed anywhere in the floor on six-inch centers, can be added or changed with little expense. Ask us for the complete story on General Electric Q-Floor wiring.

General Electric Black conduit is a useful partner of General Electric



White. It is coated with a hard, baked-on finish that provides outstanding protection from liquid chemicals, fumes, acids, and oils.

**STRONG
RUSTPROOF
CORROSION-RESISTANT
ATTRACTIVE**

ALCOA ALUMINUM UTILITY RAILINGS

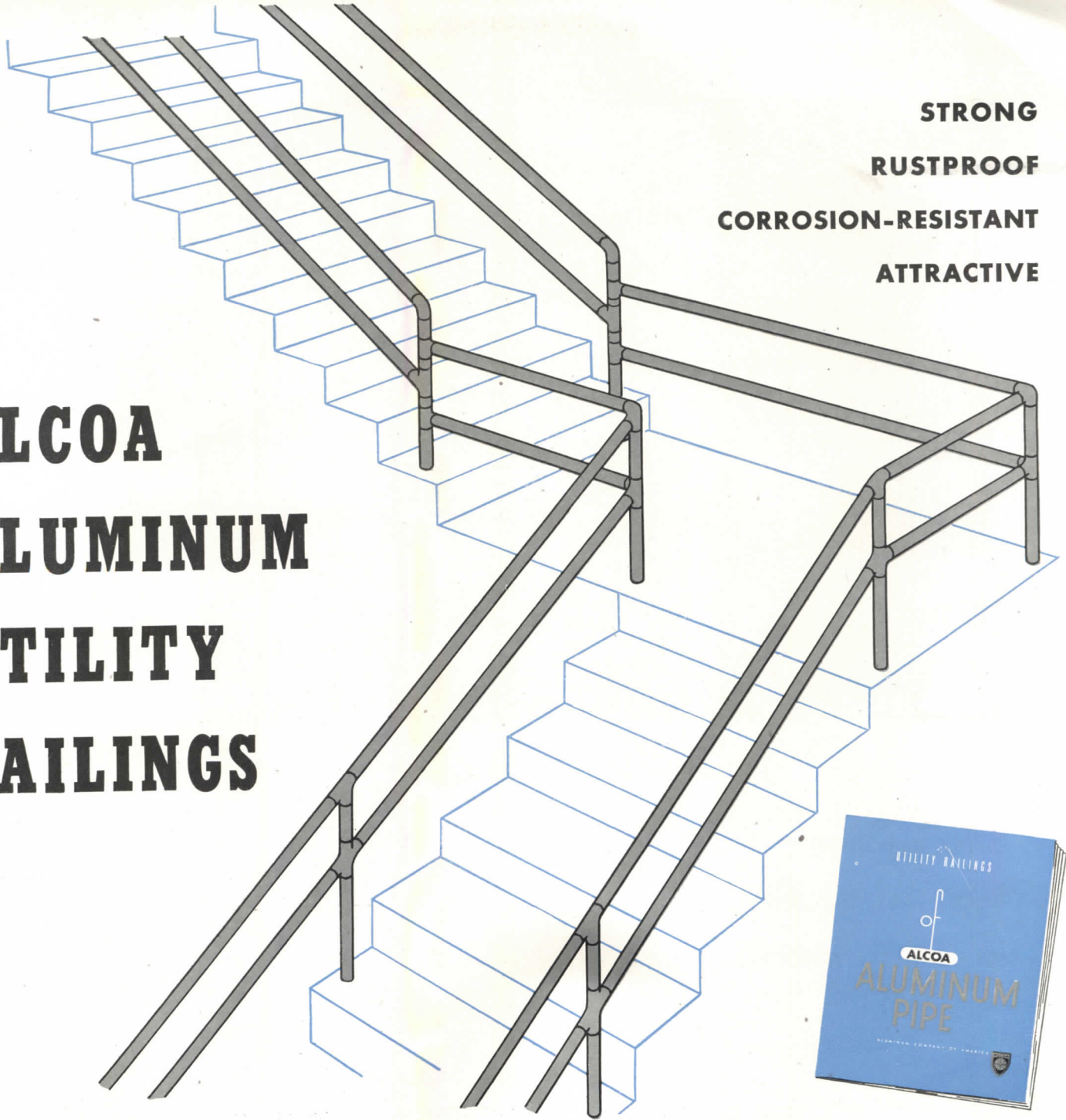

Used for utility railings, Alcoa Aluminum Pipe is rustproof and corrosion-resistant. It cannot cause streaking or staining of adjacent surfaces. Strong, it provides adequate protection. Attractive, it enhances the appearance of buildings. Easy to work, produced in a variety of standard shapes,

sizes, and fittings, Alcoa Utility Railings may be installed quickly and at low cost.

The Alcoa Booklet, illustrated (A.I.A. File No. 14-D), contains detailed information. For copies, write to ALUMINUM COMPANY OF AMERICA, 1867 Gulf Building, Pittsburgh 19, Pennsylvania.

MORE people want **MORE** aluminum for **MORE** uses than ever

ALCOA **FIRST IN** **ALUMINUM**



I N E V E R Y C O M M E R C I A L F O R M

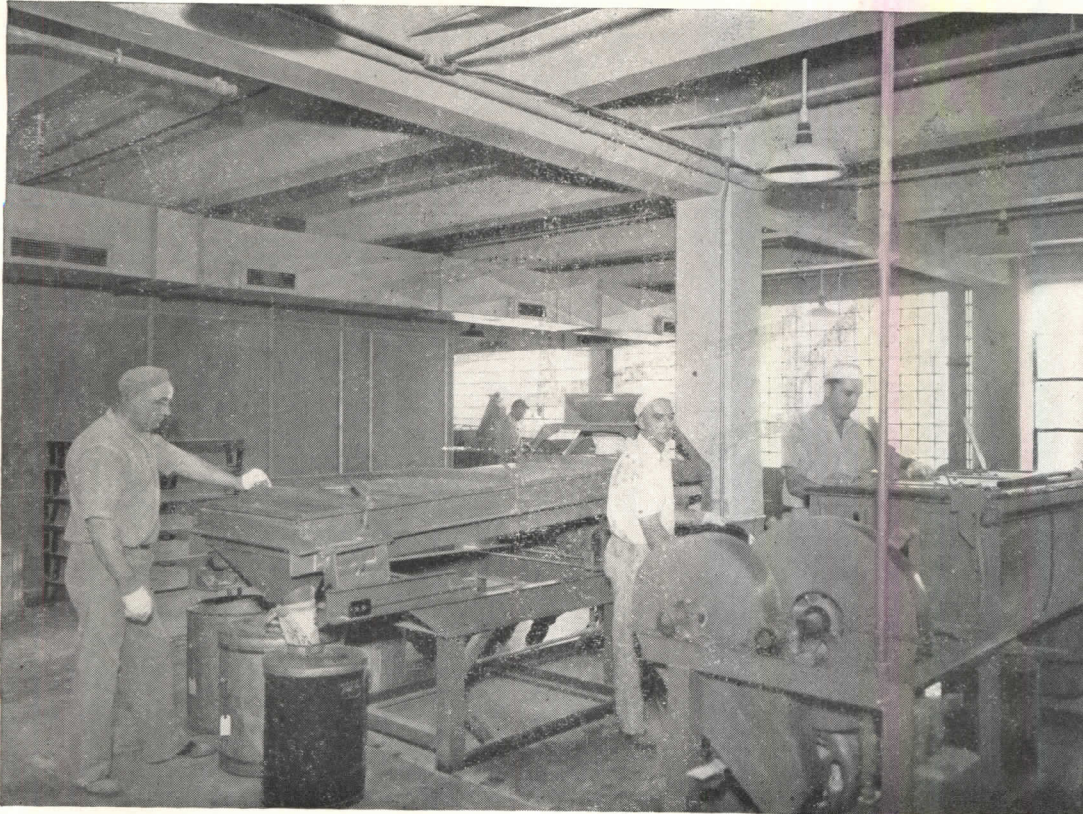

**air conditioning
helps foot the bill
for modern industrial building**

Air conditioning has long been improving quality and speeding production in almost every type of industry. But the advantages of Carrier air conditioning start even before production begins. It helps in planning a more efficient modern factory, actually keeps building costs down.

With air conditioning, high ceilings are no longer needed to supply proper ventilation. Conditioned air — cooled or heated according to the

season — is supplied continuously to every part of the plant. Reducing the over-all height of the plant naturally slashes building costs.

Carrier air conditioning leads to further savings in the completed plant. Employees work more efficiently in conditioned air, and produce more. In textile mills, metal-working shops, chemical plants and many other industries, close control of humidity and temperature smooths

out production wrinkles and helps make better products. In many plants air conditioning pays its way in a short time and goes on to pay increased dividends indefinitely.

Air conditioning by Carrier reflects over 40 years of leadership in the field. It gives you the extra benefits of Carrier's research and world-wide experience, its "know-how" and manufacturing skill. Carrier Corporation, Syracuse, New York.



**{ AIR CONDITIONING
REFRIGERATION
INDUSTRIAL HEATING**

There is no substitute for
TRUE CHURCH TONE

or for the glories of
majestic Organ Ensemble . . .



AN organ, like an orchestra, achieves its fullest glory when all its voices are blended into one brilliant ensemble. This is particularly important in church music, to produce the soul-stirring inspiration of a majestic processional or a triumphant hymn.

The new Wurlitzer Organ provides a magnificently beautiful ensemble from both manuals and pedal. Each individual tone contributes its harmonious part to produce a superb tonal climax comparable only to the traditional pipe organ. This glorious effect may be achieved gradually, through the use of stop tablets or the Crescendo pedal; or the organist may change *instantly* from any group of stops to full organ merely by pressing a combination piston.

For more detailed description of the Wurlitzer Organ—*Music's Richest Voice*—write Dept. AR-5, The Rudolph Wurlitzer Co., Organ Division, N. Tonawanda, N. Y.



The **WURLITZER ORGAN**
Series 20 Two-Manual



In just about six minutes the screw will be driven and the lower vertical rod connected. Another door will be ready to provide safe exit for the occupants of the building . . . safe exit by day and by night, in winter and in summer, as long as the building stands.

For this is a genuine drop-forged Von Duprin self-releasing fire and panic exit device . . . the surest, strongest, fastest exit device made. Its sturdy drop-forged working parts are so resistant to wear that the device operates for many years without adjustment or attention. It releases instantly even under the hand of a small child. It is so greatly over-strength in every part that it easily stands up under the terrific demands imposed by the rush of a panic-stricken crowd.

You are assured of the utmost in safe exit when you insist on genuine drop-forged Von Duprins.

Von Duprin

TRADE MARK REG.
DIVISION

VONNEGUT HARDWARE CO., INDIANAPOLIS 9, INDIANA

"A thing of beauty, and a joy forever!"

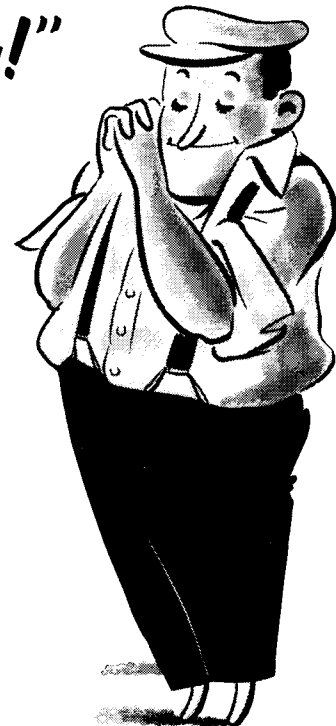
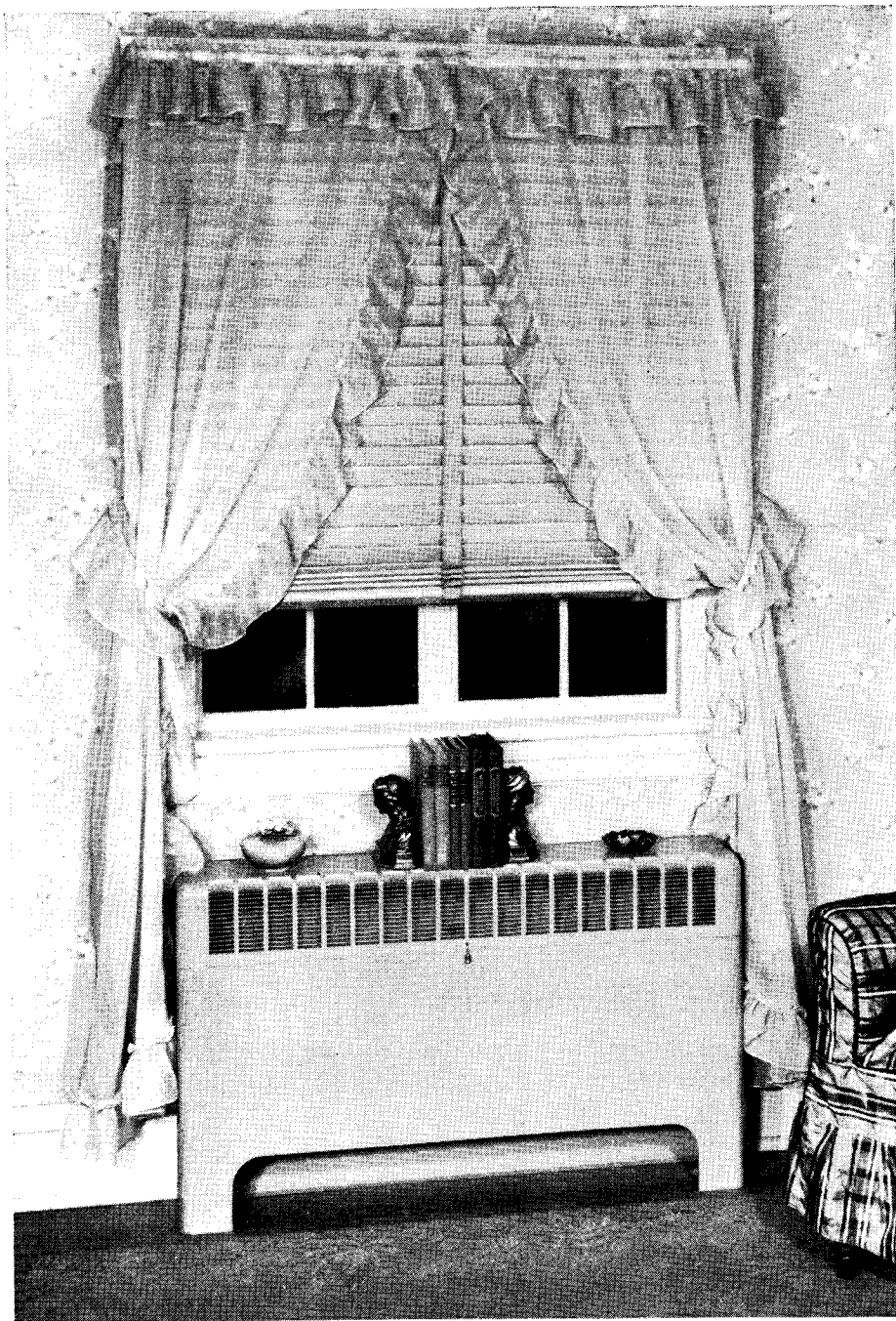

"Me . . . I'm for Nesbitt, 100 per cent! I've known them for years and all their products are good. But take their Model U—there's a convector for you!

The "U" stands for universal. That means one cabinet, for free-standing or semi-recessed jobs; one heating element, for steam or hot water; one style headers, for just about any possible connection. And there's a damper, too, when needed.

So light to carry! Easy to install, and no grief afterwards! For quality construction and modern appearance, Nesbitt Model U Convectors can't be beat.

I pick them up at my wholesaler's as I need them, in their strong protective cartons. Nesbitt sure has made this heating business a joy forever!"

Nesbitt Model U Convectors are available in 20" and 24" heights, and in lengths from 20" to 64"—twenty stock sizes, 18.5 to 71 E.D.R. The one cabinet is for free-standing or semi-recessed installation. The one heating element, with copper tubes and plate type aluminum fins, is for steam or hot water. The one style headers are tapped for all practical connections. An economical production-line, packaged commodity. Sold through plumbing and heating wholesalers. Send for Publication 252.

NESBITT CONVECTORS

SOLD EXCLUSIVELY THROUGH PLUMBING AND HEATING WHOLESALERS

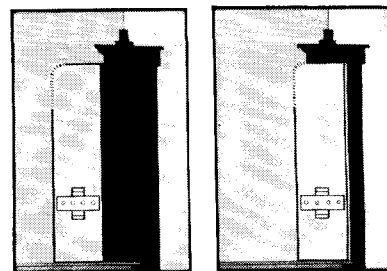

Nesbitt Model U Convectors may be installed either free-standing or semi-recessed.

A product of JOHN J. NESBITT, INC., State Road and Rhawn Street, Philadelphia 36, Pa.



For Offices

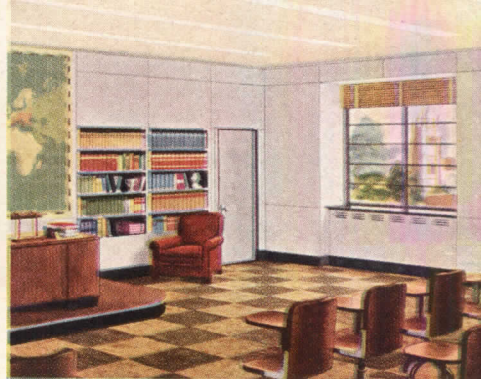

... for University Lecture Rooms



... for Laboratories

For colorful... quieter

1. J-M ACOUSTICAL CEILINGS*—noise-quieting, economical, attractive

There's a Johns-Manville sound-absorbing ceiling for every kind of interior, whether it's a school or a hospital, an office or a restaurant, a large auditorium or a noisy factory.

To assure you the maximum in noise-quieting, Johns-Manville not only provides the correct acoustical materials for each specific condition, but follows through by installing the materials properly with its own construction crews. In other words,

you get "J-M materials installed by Johns-Manville" for best results.

That's the all-inclusive service . . . the *undivided responsibility* Johns-Manville gives every project.

For further details, send for brochure entitled, "J-M Sound Control." Describes such J-M acoustical products as Sanacoustic, Fibracoustic, Fibretex and Fibretone, Transite Acoustical Panels and special materials for Broadcasting Studios.

2. J-M TRANSITE WALLS*—movable, to provide for change

Rooms when and where you want them . . . that's the magic of Johns-Manville Transite Walls—the attractive and sturdy asbestos walls that are *movable*. Now you'll never again need to send partition walls to the dump every time space changes are required!

With the least inconvenience—almost *overnight*—you can enlarge, decrease, or rearrange areas as often as your needs require. Transite movable panels are

easy to handle, readily assembled, interchangeable, and can be used over and over again. Made of asbestos and cement, Transite Walls have all the qualities of solid and permanent construction. They provide rigid, double-faced partitions, and can also be used as the interior finish of outside walls.

To make sure your interiors will provide for *change*, write for booklet, "J-M Transite Movable Walls."

3. J-M ASPHALT TILE FLOORS*—for beauty and greater comfort underfoot

They're colorful! They're more resilient! More restful to walk on! And they're extra long-wearing—reinforced with fibers of indestructible asbestos. Even a carelessly dropped lighted cigarette won't mar their built-in beauty.

Johns-Manville Asphalt Tile is the modern flooring that can take *heaviest* foot traffic, yet stay fresh and unmarred with practically no maintenance.

And you'll *like* the unlimited range of possible color combinations—from striking patterns with strong contrasts to solid fields of marbleized colors. Easy on the eyes, J-M Asphalt Tile Floors are easy on the budget, too!

For areas exposed to oil or grease, use J-M *Grease-Proof* Asphalt Tile. Send for full-color brochure, "Ideas for Decorative Floors."

* Use all three products for Johns-Manville Unit Construction . . .



Johns-Manville

ADDRESS: BOX 290, NEW YORK 16, N.Y.

To provide for ever-changing space needs, give your interiors *complete flexibility* with J-M Unit Construction. This new method combines movable Transite Walls, demountable Acoustical Ceilings, Asphalt Tile Floors—in other words, the *complete interior*, under *one* specification, *one* manufacturer's responsibility. Write for brochure on J-M *Unit Construction*.

Because of unprecedented demands, there may be times when we cannot make immediate delivery of materials. So please anticipate your needs.

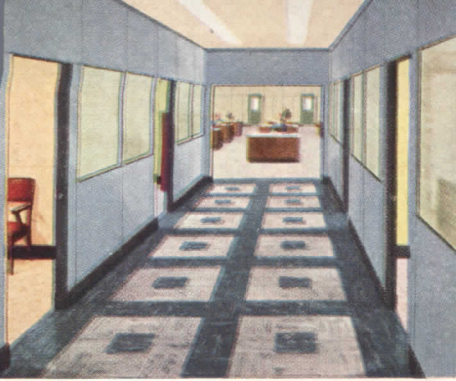

... for Institutions and Hospitals

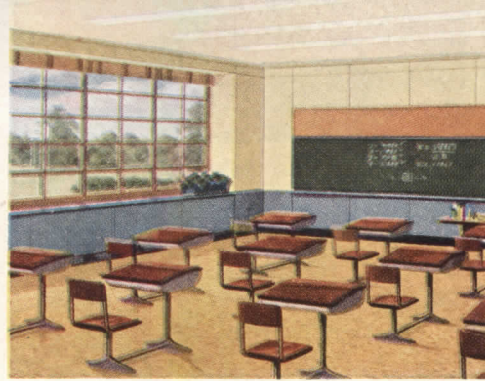

... for Schools

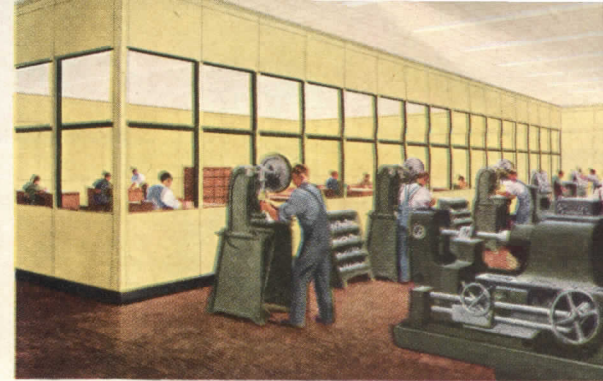

... for Factory Areas

flexible interiors

Typical example of Johns-Manville Unit Construction — a beautiful, completely flexible interior . . . with movable Transite Walls, Asphalt Tile Flooring, and a demountable Sanacoustic Ceiling to absorb noise.

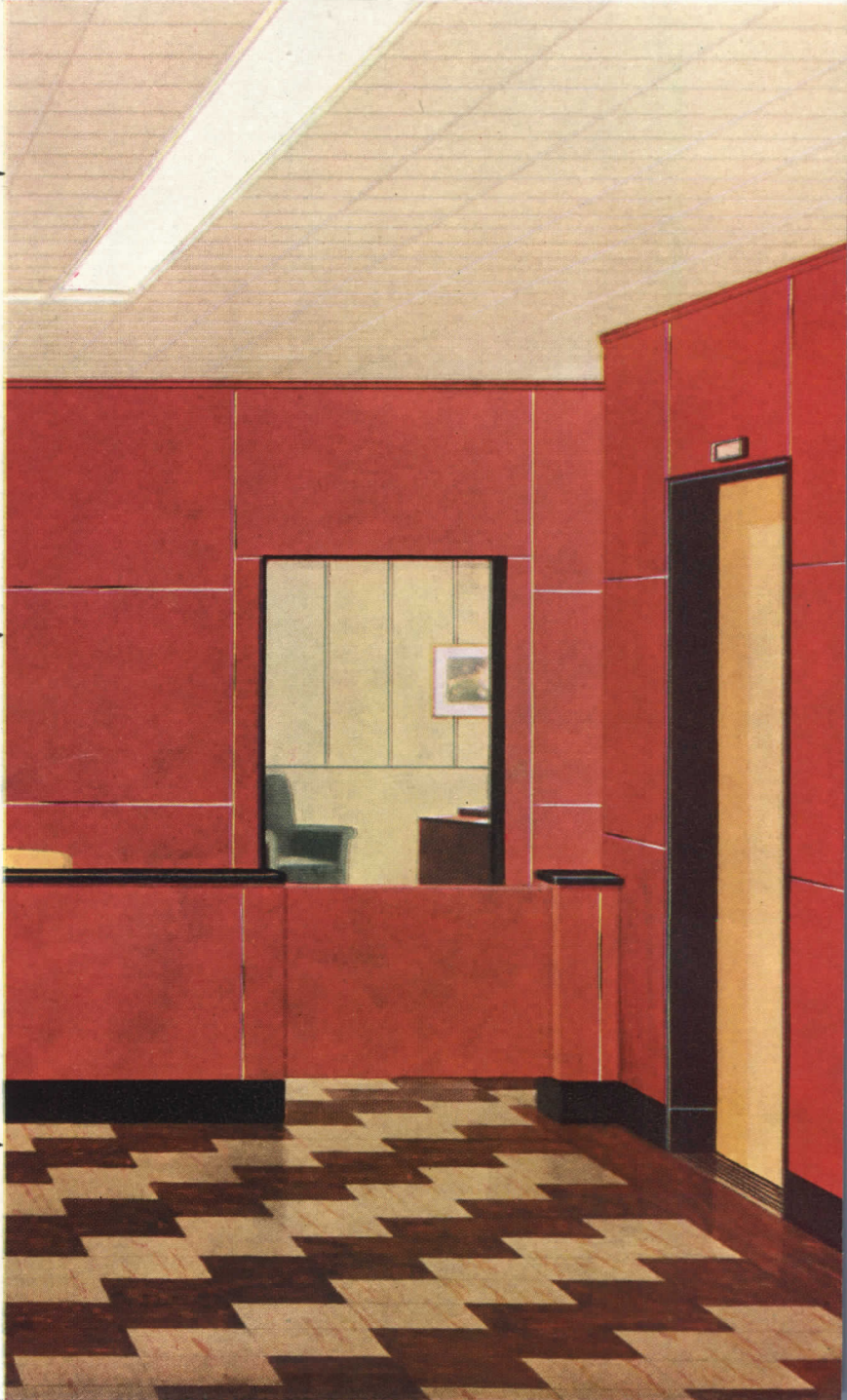

**"WE CUT STEAM COSTS 48%
—and paid for conversion in 10 months"***



**YOU SAVE 3 WAYS WITH ENTERPRISE *Oil Burners*
—IN EFFICIENCY, CLEANLINESS AND ECONOMY**

Cutting steam costs by almost half seems unbelievable. Yet this is but one of innumerable conversion jobs from old-fashioned, uneconomical combustion systems to Enterprise Oil Burners that proves the rule of exceptional savings in fuel costs, minimum upkeep, and continuous efficiency under the most exacting requirements.

A leader in the field, Enterprise manufactures rotary oil burners in a wide range of heavy-duty models—with a flexibility of application to meet the needs of modern building and industry in all its branches. Enterprise burners are furnished in Manual, Semi-Automatic and Fully-Automatic Models in combination with modulating fire control or any desired special combinations.

Whether you are considering combustion equipment for a new installation or as a replacement of obsolete units, plan to investigate Enterprise Burners. A call to your nearest Enterprise distributor, or a letter to the Combustion Equipment Division in San Francisco, will bring a prompt answer to questions regarding your particular problems.

* From a statement by the Director of THE DOCTORS HOSPITAL in Seattle.

Installed by Superior Engineering Co. of Seattle, two of these Model H2P Semi-Automatic Enterprise Oil Burners operate 24 hours a day producing 4,000 pounds of steam per hour for The Doctors Hospital heating, sterilizing and laundry needs.

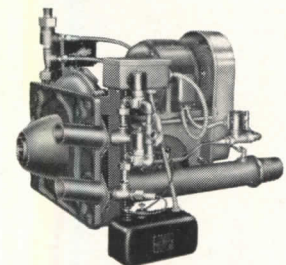

**ENTERPRISE
*Oil Burners***

DISTRIBUTORS IN PRINCIPAL CITIES

COMBUSTION EQUIPMENT DIVISION OF
ENTERPRISE ENGINE & FOUNDRY CO.
18TH AND FLORIDA STREETS, SAN FRANCISCO 10, CALIFORNIA

DIESEL ENGINES • PROCESS MACHINERY • OIL BURNERS • HEAVY MACHINERY

Kimpreg* ... Plastic Armor fused to Plywood



PROTECTS AGAINST WEATHER. Kimpreg-surfaced plywood withstands rain, snow, and extremes in temperature. An amazing success when used for trailer coaches, table or bar tops, and boat decking. Easily adaptable to many other types of construction exposed to rough wear and weather.

INCREASES DURABILITY. Fusing Kimpreg—a thermosetting phenolic material—to the surface of any type of plywood produces Kimpreg + Plywood. Snag-proof, scuff-proof, highly resistant to weak acids, impervious to alcohol.

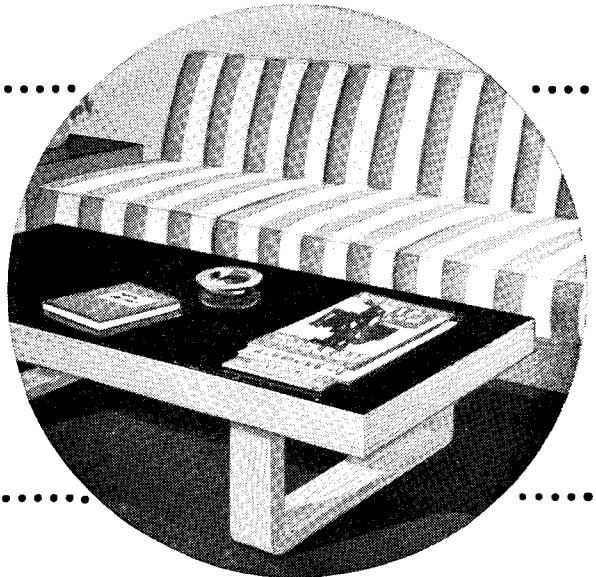

MYRIADS OF USES are possible with this light, strong material. Mail the coupon today for more complete details and for the names of manufacturers who produce remarkable Kimpreg + Plywood. *If you cannot get all the Kimpreg-surfaced plywood you need, please be patient until the resin supply is more plentiful.*

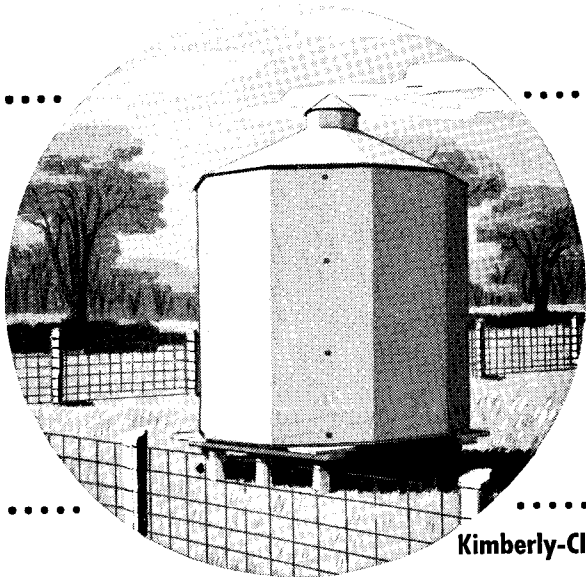

Kimberly-Clark Corp., Neenah, Wis. Please send me the free Kimpreg book and the names of manufacturers making plywood surfaced with Kimpreg.

Kimpreg
REG. U.S. PAT. OFF.
PLASTIC SURFACING



Name _____

Firm _____

Type of Business _____

Address _____

City, Zone, State _____

AR-547

*TRADEMARK

probably in your own
files right now



CONDENSED DATA ON OKONITE WIRES AND CABLES

FOR EVERY ELECTRICAL APPLICATION

*I*t's easy to get the facts you need about the insulated wires and cables you need. Chances are you'll find them in the pre-filed catalogs now in your office library. Among many reference publications, Okonite presents its condensed data in Sweet's Engineering, Power Plant, Mechanical Industries and Process Industries Catalogs as well as Electrical Buyers' Reference.

Here you'll find information on building wire, power cables for overhead, underground and submarine use, control and signal cables, apparatus cable and other Okonite time-tested electrical products. Here you'll find also recommended applications, ranges of sizes and voltage and operating temperature limits — all in convenient, easy-to-use form. If you don't have these pre-filed catalogs, write for Bulletin OK-1031 to The Okonite Company, Passaic, N. J.

5074

OKONITE  **SINCE 1878**

insulated wires and cables

Valuable **FREE** Bulletin

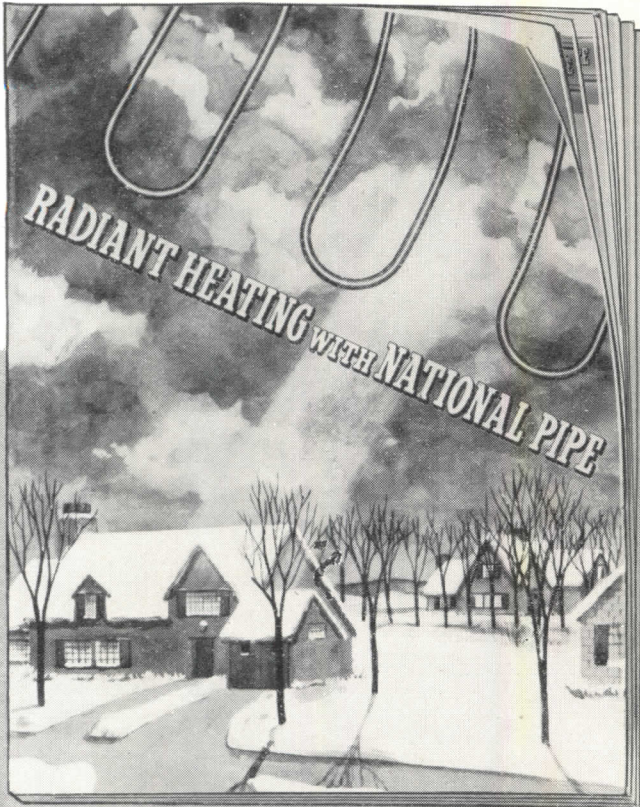

Tells what
you want to know about

Radiant Heating

THIS 48-page book, "Radiant Heating with National Pipe" is one of the most interesting books published on the subject. It brings you a well-rounded story of radiant heating and gives the latest available information as a basis for the planning and installing of an efficient system.

Architects, heating engineers and contractors will find the book valuable for use in planning new installations. It answers almost any important question about radiant heating. For example—

- What is radiant heating?
- How radiant heating is designed for comfort.
- How to estimate heat losses.
- How to determine radiant heating coil requirements.
- Radiant heating comfort chart.
- What heating engineers claim for radiant heating.
- Methods of floor and ceiling installation.
- Typical pipe coil patterns.
- Questions and answers on radiant heating.
- Heat transmission tables.

What is the approximate cost of a radiant heating system?

Would it cost more or less to operate a radiant heating system than other types, and by how much?

What effect do rugs and rug pads have on heat transfer in a radiant heating system?

These and many other questions are competently answered and complete information is given for calculating the pipe sizes for various conditions. Mail the coupon and a copy of this valuable book will be sent at once.

Send for a copy **TODAY**



NATIONAL TUBE COMPANY
PITTSBURGH, PA.

Columbia Steel Company, San Francisco, *Pacific Coast Distributors*
United States Steel Export Company, New York

National Tube Company
Frick Building
Pittsburgh, Pa.

Gentlemen:

Please send me a copy of your FREE book, "Radiant Heating with National Pipe."

Name.....

Position.....

Company.....

Address.....

UNITED STATES STEEL



Limestone is elected to more offices than any other stone

★ These are only a few of the hundreds of great American office buildings made of beautiful, durable, inexpensive Indiana Limestone. Our Technical Division, with a century's experience in all applications of the nation's *most frequently specified* building stone, offers you personal counsel on questions unanswered by our Sweet's File Catalog.

You are invited to forward plans and specifications to the Institute for competitive cost estimates by our 20 member companies. P.O. Box 471, Bedford, Indiana.

BUFF • GRAY • VARIEGATED • RUSTIC • OLD GOTHIC

INDIANA LIMESTONE INSTITUTE

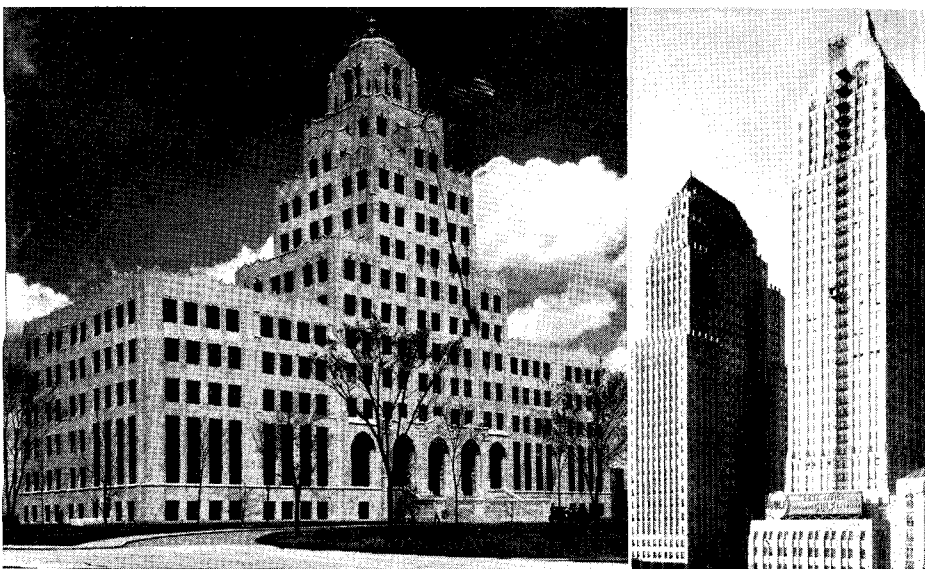

STALEY

KOPPERS

GULF

ALDRED & CO.

Montreal, Barott & Blackader, Architects

BOARD OF TRADE

Chicago, Holabird & Root, Architects

EMPIRE STATE

New York, Shreve, Lamb & Harmon, Architects

FORD ROTUNDA

Detroit, Albert Kahn, Inc., Architect

FOREMAN & CLARK

Los Angeles, Curlett & Beelman, Architects

GENERAL MOTORS

Detroit, Albert Kahn, Inc., Architect

GULF

Pittsburgh, Trowbridge & Livingston, Architects

JEWEL TEA

Barrington, Ill., Holabird & Root, Architects

KOPPERS

Pittsburgh, Graham, Anderson, Probst & White, Architects

LEVER BROTHERS

Cambridge, Mass., Shreve, Lamb & Harmon, Architects

MERCHANDISE MART

Chicago, Graham, Anderson, Probst & White, Architects

PALMOLIVE-PEET

Chicago, Holabird & Root, Architects

ROCKEFELLER CENTER

New York, Reinhard & Hofmeister; Raymond Hood, Godley & Foulhoux; Corbett, Harrison & MacMurray, Architects

STALEY

Decatur, Ill., Aschauer & Waggoner, Architects

TISHMAN

(New York, world's first completely air-conditioned office building), Kahn & Jacobs, Architects

MEMO

Write "Ohio Chemical"
for info. Explosion-
Proof Scanlan-Morris
surgical lights

EXPLOSION-PROOF OPERAY MULTIBEAM
WITH TWO EXPLOSION-PROOF CEILING LIGHTS
A3289A WITHOUT CEILING LIGHTS

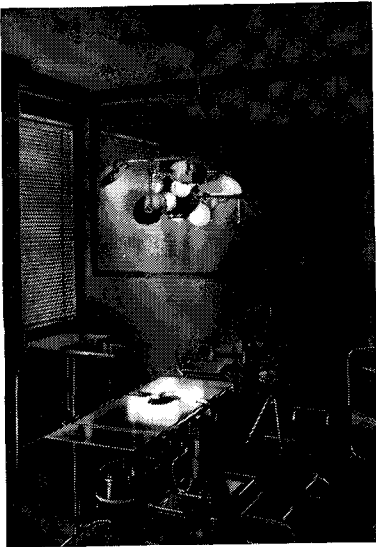
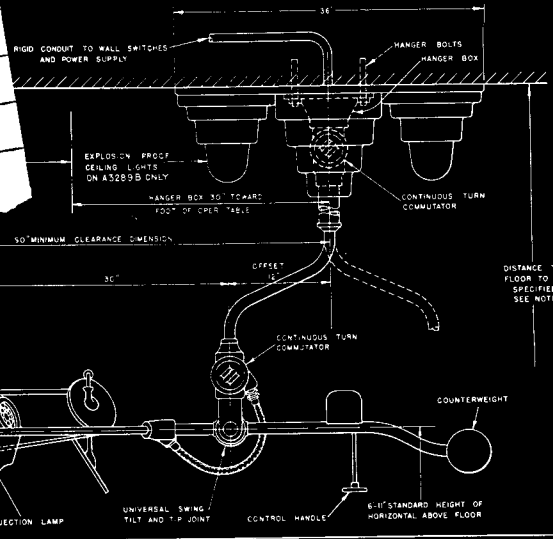

Explosion-Proof Operay Multibeam Light

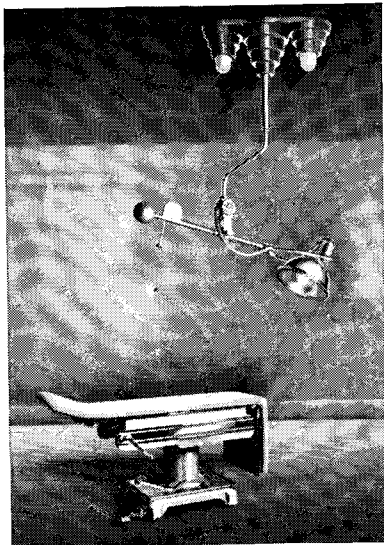

Explosion-Proof Operay Surg-O-Ray Light

Ceiling
HOSPITAL FLOOR PLANS
should include provision for
Explosion-Proof Surgical Lights

• For more than 40 years architects and hospitals have received valuable assistance and authentic guidance in planning for many major items of hospital equipment manufactured by Scanlan-Morris. They have found this service especially helpful in planning for surgical lighting.

Efficient surgical lighting plus adequate protection against fire and explosion hazards in the anesthetic area is the dual accomplishment of Scanlan-Morris Operay explosion-proof surgical lights. These fixtures are approved by Underwriters' Laboratories for use in Class 1 Group C Hazardous Locations—a classification that includes operating and delivery rooms employing explosive anesthetic gases.

Scanlan-Morris Operay lights are

widely used in prominent hospitals. The lights are made in two general types, as illustrated: Operay Multibeams and Operay Surg-O-Ray. The ceiling fixtures are furnished either with or without auxiliary ceiling lights for general illumination.

The Scanlan-Morris Technical Sales Service Department will be glad to supply complete information, including installation drawings, and will also welcome opportunities to cooperate with architects in correct planning for surgical lighting based on building plans. Such service is freely offered, without obligation, not only on surgical lighting but also on sterilizing equipment, recessed cabinets and other major items of hospital equipment manufactured by Ohio Chemical. Mail the coupon for detailed information.

Ohio Chemical

MANUFACTURERS OF MEDICAL APPARATUS,
GASES AND SUPPLIES FOR THE PROFESSION,
HOSPITALS AND RESEARCH LABORATORIES



BRANCH OFFICES IN PRINCIPAL CITIES

THE OHIO CHEMICAL & MFG. CO.
1400 East Washington Ave., Madison 3, Wisconsin

Represented in Canada by Oxygen Company of Canada, Limited, and Internationally by Airco Export Corporation, 33 West 42nd Street New York

THE OHIO CHEMICAL & MFG. CO.,
1400 E. Washington Ave., Madison 3, Wis.

Send information on Scanlan-Morris Explosion-Proof Surgical Lights. (Please attach professional card or letterhead)

Name

Address

City State AIR

THRUSH

Forced Circulating
FLOW CONTROL HOT WATER HEATING

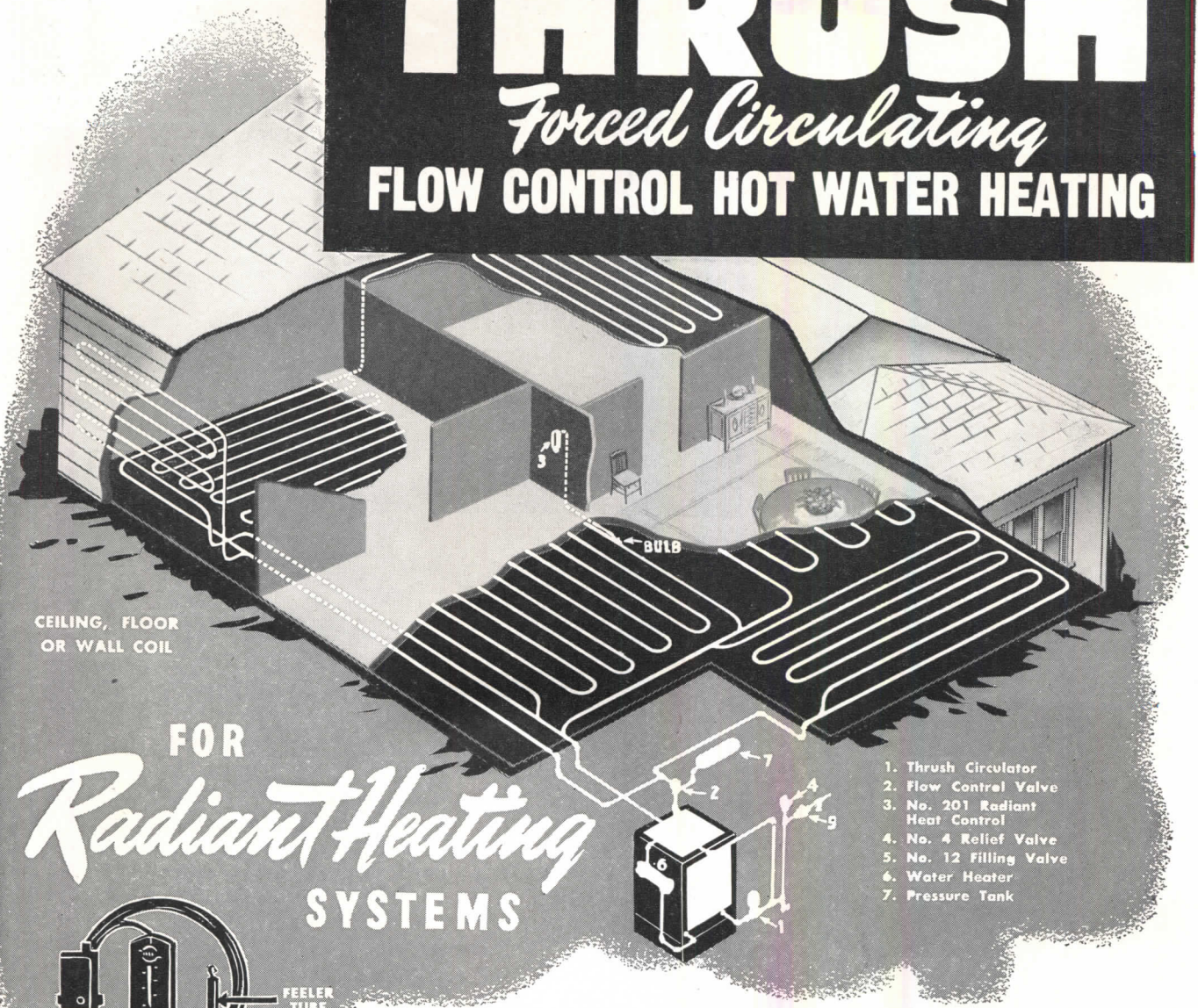

CEILING, FLOOR
OR WALL COIL

FOR
Radiant Heating
 SYSTEMS

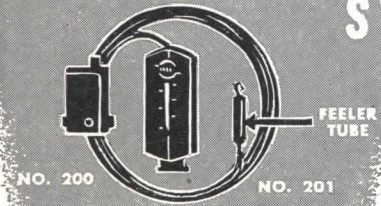

NO. 200
 THRUSH RADIANT
 HEAT CONTROL

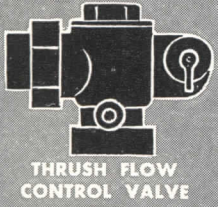

THRUSH FLOW
 CONTROL VALVE

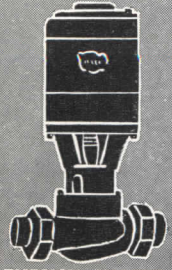

THRUSH WATER
 CIRCULATOR

1. Thrush Circulator
2. Flow Control Valve
3. No. 201 Radiant Heat Control
4. No. 4 Relief Valve
5. No. 12 Filling Valve
6. Water Heater
7. Pressure Tank

THRUSH Forced Circulating Flow Control System is the best and most economical method of controlling warm water heat. It regulates water temperature to maintain absolutely uniform comfort, night or day, regardless of outdoor weather. It provides constant Radiant Heat. The feeler tube, an integral part of the Thrush Radiant Heat Control, senses the slightest change in water temperature and acts automatically to restore room temperature before it can drop more than a fraction of a degree. Operating cost is low because continuous circulation is not required. The Thrush Circulator normally operates only a few minutes out of each hour and firing unit operating periods are shorter. For more information write Dept. J-5 or ask your Wholesaler.

H.A. THRUSH & COMPANY
 PERU • INDIANA

KIESLING

PASSENGER AND FREIGHT ELEVATORS

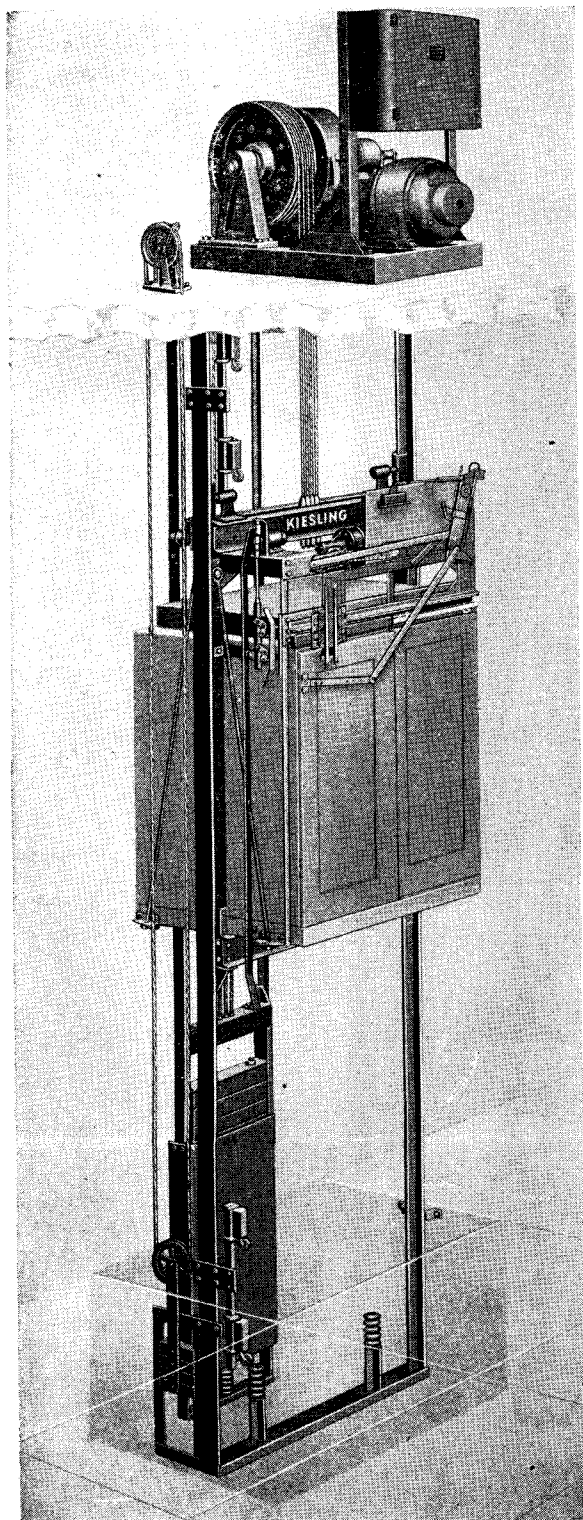

KIESLING Passenger Elevators are designed to cover a wide range of service and are adaptable for use in apartment and office buildings, hospitals, hotels, department stores, and residences, etc. An unlimited number of car sizes are obtainable, providing capacities and speeds to suit particular requirements.

KIESLING Passenger Elevator can be provided with various types of control, designed to meet with individual requirements. Single speed, Two speed, or Variable Voltage controls are available. Motorized Car and Hoistway Doors as well as Automatic Levelling, can be furnished. We provide complete service, maintenance, and modernization of existing equipment.

Architects and engineers are invited to write for complete descriptions and illustrations of KIESLING ELEVATORS.



NOT TO BE OPENED UNTIL
THE N. A. M. P.
CONVENTION & EXHIBITION
MILWAUKEE
MAY 26 TO 29

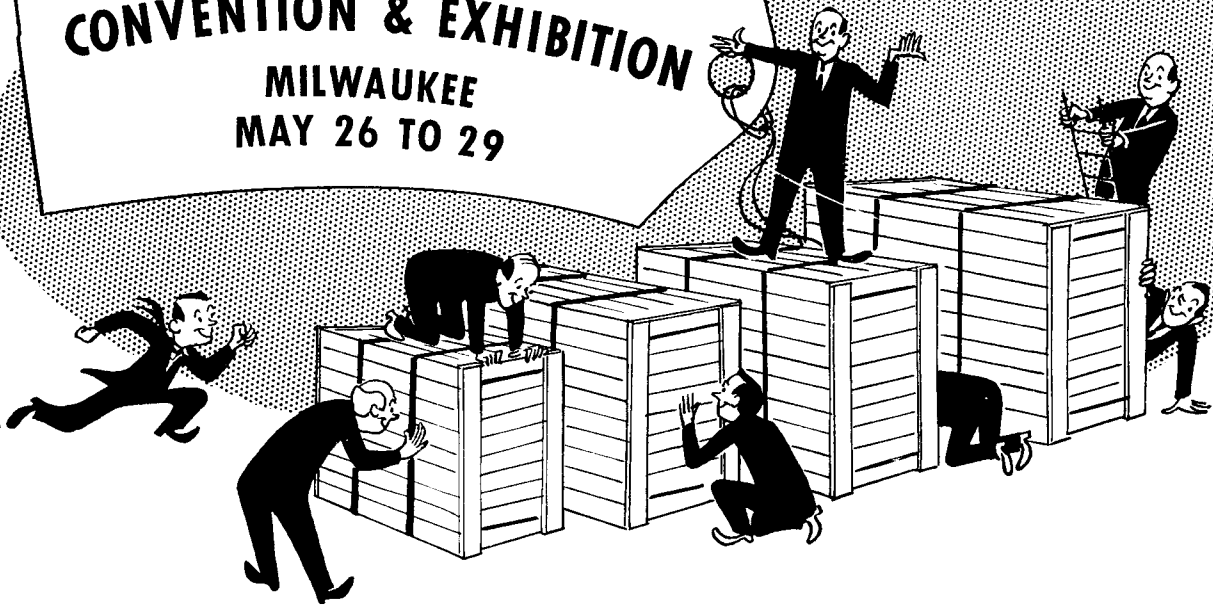

You'll agree:

THE *NEW* HEAT EXTRACTORS
are worth waiting for!

At Milwaukee, you'll see the results of seven years of design and research—to prove that there's really something *new* in the radiant heating industry. You'll have an opportunity to judge for yourself when you see this new, still better generation of a distinguished heating family—but that's all we can tell you now!

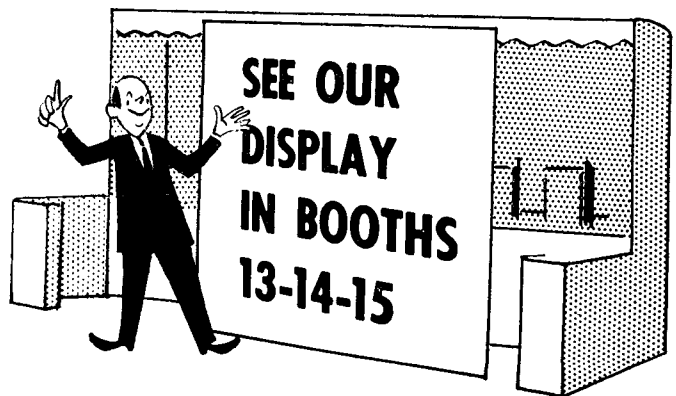

The NATIONAL RADIATOR Company
JOHNSTOWN, PENNSYLVANIA



Small jobs, too, can bear
the mark of distinction!

ARCHITECTURAL METALS

give functional beauty

to many items, both large and small

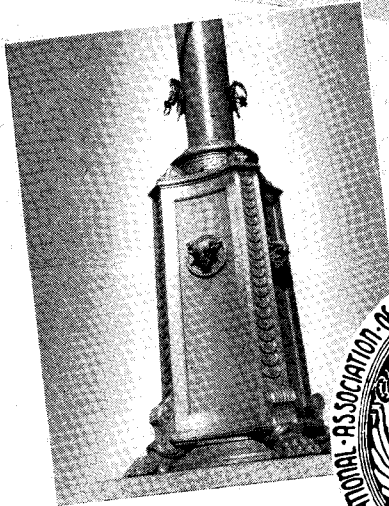
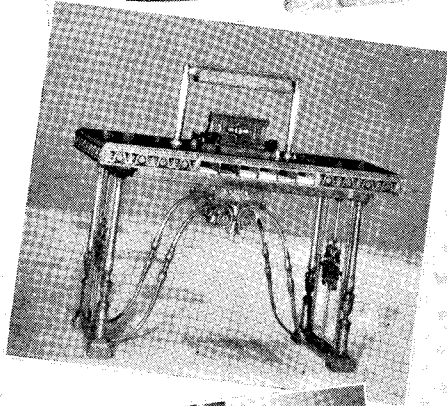

You know how much beauty, distinction and durable construction Architectural Metals give to the larger jobs you design—store fronts, marquees, entrances, gateways, etc.

But have you considered how these versatile metals can do the same thing for smaller jobs, such as tablets, flagpoles, check desks, grilles, directories or other small fixtures? You see, there are practically no limitations to the ways you can use Architectural Metals.

Architectural design can find freedom of expression in the many combinations which are possible with these enduring metals. Ferrous and non-ferrous metals of many different colors, qualities and strengths can be fabricated to your own ideas and plans. You can add permanence, strength, beauty and utility to any item you design.

Why not call upon the manufacturers and fabricators of Architectural Metals whenever you have a designing problem which they can help you solve? A Directory of Leading Metal Fabricators—who are anxious to serve you—will be gladly sent without obligation. Address your request to Dept. AR-5.



NATIONAL ASSOCIATION OF

ORNAMENTAL METAL MANUFACTURERS

209 CEDAR AVENUE, TAKOMA PARK, WASHINGTON 12, D. C.

Maintenance men get a break

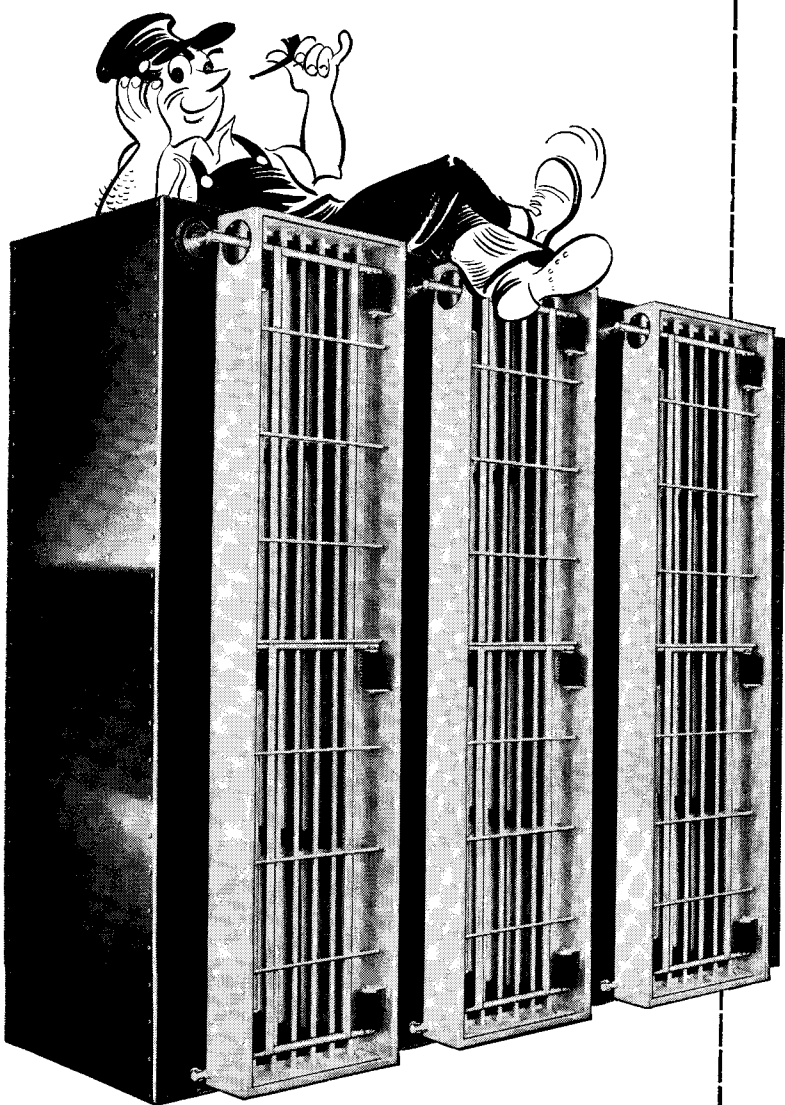

and you get a bonus in the Electro-Airmat

EVER clean an air filter? If you have, you will appreciate the maintenance man's enthusiasm for the modern Electro-Airmat.

Here is a dry-type electronic precipitator which uses Airmat paper or glass media as the filtering medium. This exclusive AAF product has thousands of successful installations to its credit in mechanical type filters. Under electrostatic charge its service life is increased 30%. When dirt-laden it is thrown away rather than cleaned, and replaced quickly and economically from a roll of new Airmat. No oil, no muss, time and labor saved and with each reloading you have a brand new filter.

Applying new Airmat paper with mechanical loader

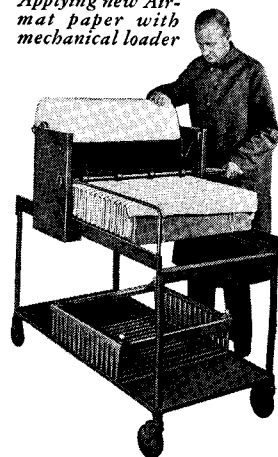

Now, where's your bonus? First, efficiency. Tests show Electro-Airmat to have an average efficiency of 85% to 90% by the Bureau of Standards Discoloration Test Method. Second, economy. Costly water connections, drains and watertight base are eliminated. Third, continuous protection. Electro-Airmat combines the best of electronic and mechanical filtration. Should electronic action become inoperative due to power failure, Airmat paper carries on as a straight mechanical filter.

It's a great combination of features—all exclusive with Electro-Airmat. Catalog No. 253 contains complete information. Write for it today!

AMERICAN AIR FILTER CO., INC.

389 Central Ave. Louisville 8, Ky.

In Canada: Darling Bros., Ltd., Montreal, P. Q.



ELECTRO-AIRMAT
ELECTRONIC PRECIPITATOR

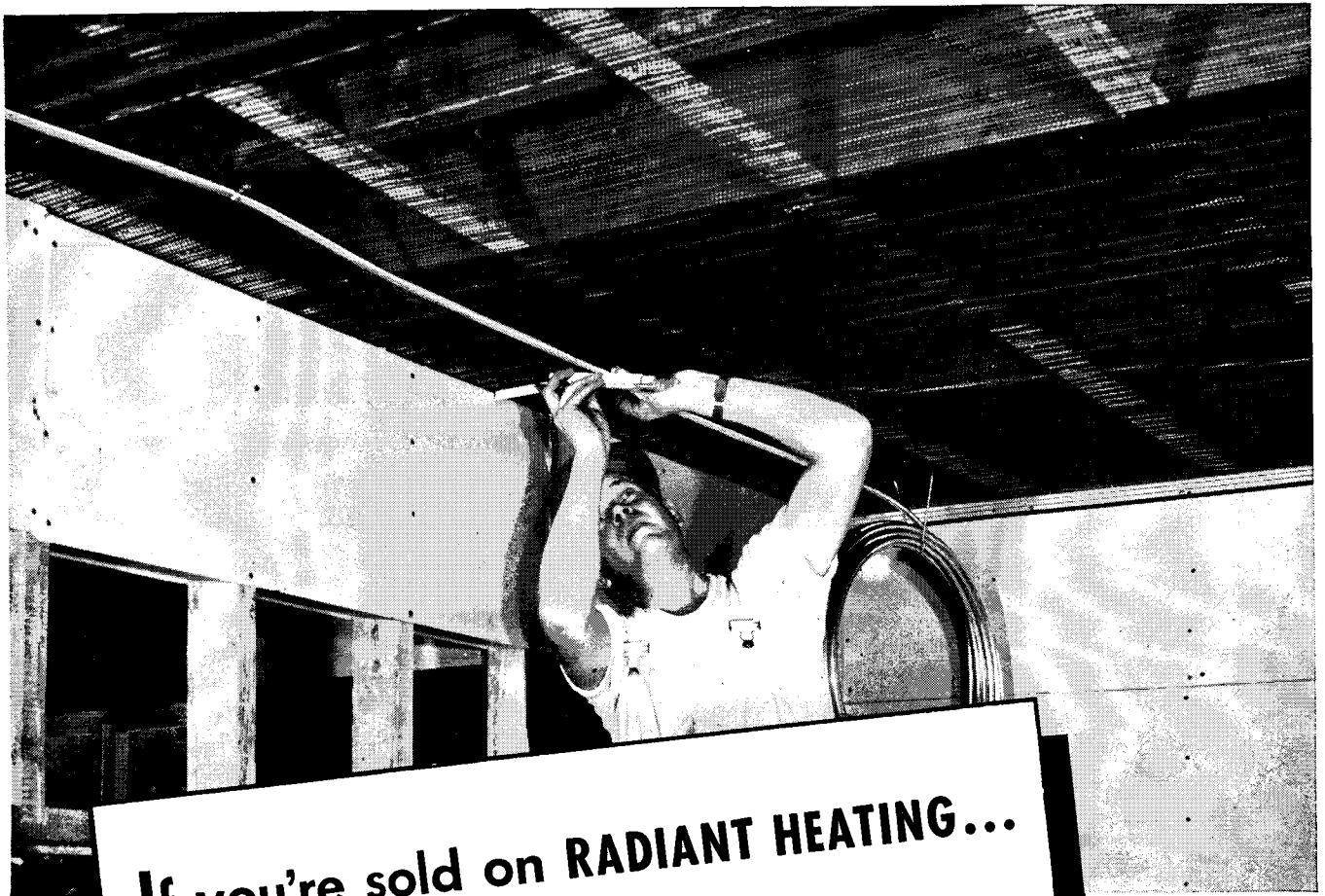

If you're sold on RADIANT HEATING...

Recommend *Copper Tube!*

IF you are sold on radiant heating, plan to use Chase Copper Tube, for copper tube has many advantages for radiant heating installations.

Copper tube can be bent easily, on the job. It is light in weight—easy to handle. And it can be installed in the standard plaster coat.

To these advantages add the long-recognized economy of Chase Copper Tube and you can see how

the specification of copper tube can make a radiant heating system appear even more desirable.

The demand for Chase Copper Water Tube is so great that we are not able to satisfy it at all times. However, the technical information is now available to you for future planning, and is being distributed throughout the building industry.

Send today for your copy. Simply address Dept. AR57.

- 7 Reasons
WHY CHASE COPPER TUBE
FOR RADIANT HEATING**
1. EASY TO BEND
 2. LIGHT IN WEIGHT
 3. SOLDERED FITTINGS
 4. SMALL DIAMETERS
 5. LONG LENGTHS
 6. LOW COST
 7. LONG LIFE

Chase  *the Nation's Headquarters for*
BRASS & COPPER

WATERBURY 91, CONNECTICUT SUBSIDIARY OF KENNECOTT COPPER CORPORATION

THIS IS THE CHASE NETWORK... *handiest way to buy brass*

ALBANY† ATLANTA† BALTIMORE BOSTON CHICAGO CINCINNATI CLEVELAND DETROIT HOUSTON† INDIANAPOLIS JACKSONVILLE† KANSAS CITY, MO. LOS ANGELES MILWAUKEE
MINNEAPOLIS NEWARK NEW ORLEANS NEW YORK PHILADELPHIA PITTSBURGH PROVIDENCE ROCHESTER† SAN FRANCISCO SEATTLE ST. LOUIS WASHINGTON† (†Indicates Sales Office Only)

WORTHINGTON

Air Conditioning and Refrigeration Report

Worthington Pump & Machinery Corporation, Harrison, New Jersey

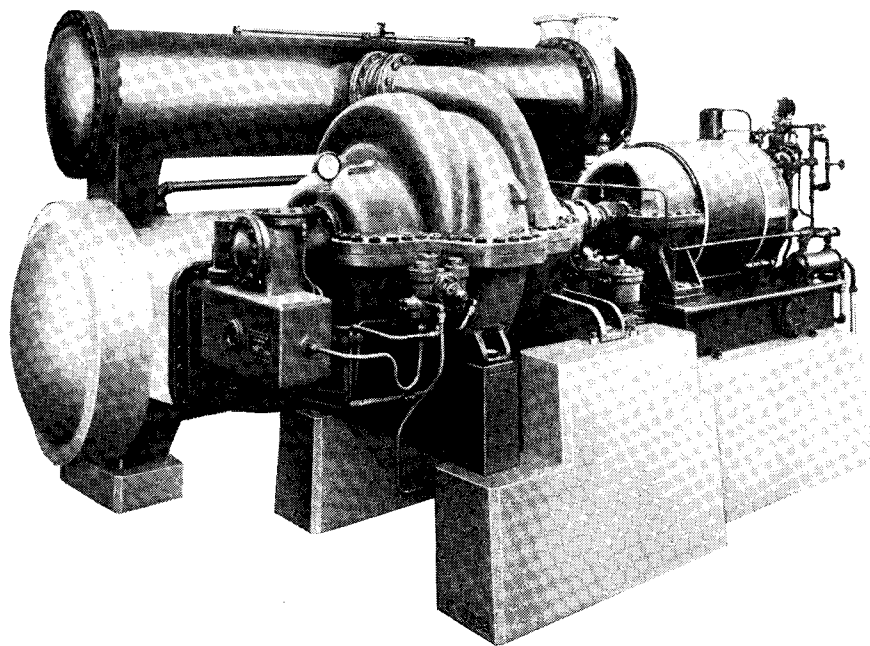

WORTHINGTON OFFERS NEW, IMPROVED CENTRIFUGAL REFRIGERATION SYSTEMS

Recently improved designs now enable Worthington to offer Centrifugal Systems for use with most refrigerants, including the lighter hydrocarbons, and for any air conditioning or cooling process — chilling water, brine, chemicals, lubricating oils, etc. — at temperatures to meet any requirement. Now designed for temperatures as low as -160°F .

In the 450-TR Centrifugal Refrigeration Unit illustrated, for example, every one of the essential elements — 3-stage compressor, water cooled condenser, specially designed horizontal evaporator and powerful

steam turbine — is Worthington designed and made.

This means perfect coordination, with the added advantage that the Worthington user can place full responsibility for his system's operation on a single manufacturer.

Other compact, space-saving units are available in capacities of 150 to 2600 tons, each engineered by Worthington to give you many years of trouble-free, low-cost refrigeration.

Worthington Pump and Machinery Corporation, Harrison, N.J. Specialists in air conditioning and refrigeration for more than 50 years.



Famous N. Y. Hotel Selects Worthington Air Conditioning

Famed for its luxurious appointments, New York's huge Commodore Hotel counts on Worthington centrifugal refrigeration equipment for a year-round supply of clean, invigorating air. Today's comfort-wise guests have learned to expect such up-to-date air conditioning as an essential feature of every modern hostelry.

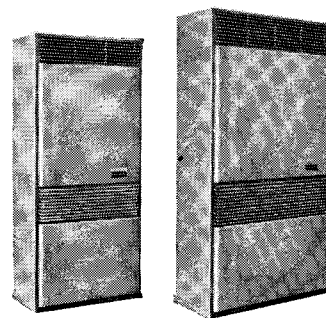

Air Conditioning in Smaller "Packages"

Worthington's Self-Contained Air Conditioners, Model SYC, are built in 3 and 5 ton refrigeration capacities. These amazingly efficient "packaged" units are ideal for promoting better health and better business in every type of smaller business and industrial organization.

The Advantages of Worthington "Integration"

Worthington, making so many of the "inner vitals" — compressors, condensers, pumps, turbines, valves, fittings, etc. — of its air conditioning and refrigeration equipment, is able to combine these units into a completely "integrated" system that will assure you long, efficient, economical service . . . another reason why *there's more worth in Worthington*. See your nearby Worthington distributor for details.

WORTHINGTON

*Air
Conditioning
and
Refrigeration*

Smithcraft SKYLITE

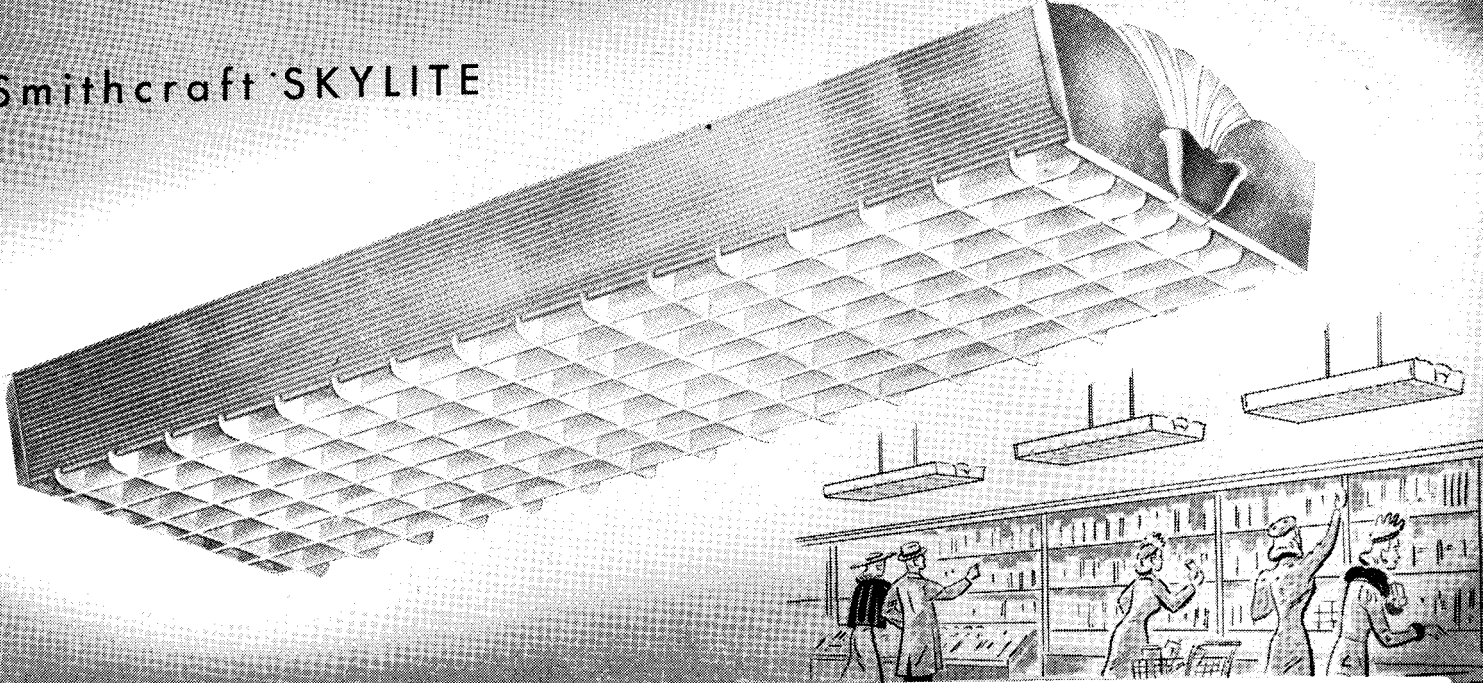

*Extra Light Output
with Minimum Glare
Due to "Skylite's" Special Features...*

FRAMELESS LOUVRE (Exclusive)
No frame to cause usual "dark spot." Result: more light
... more even brightness.

PARABOLIC SIDE REFLECTOR (Exclusive)
Gives extra useful light ... extra efficiency. Reflectors
can be installed to give 65% down ... 35% up.

**ILLUMINATED
END CAP** —

Eliminates any blackness
contrast of metal against
light. Provides distinctive
decorative feature.

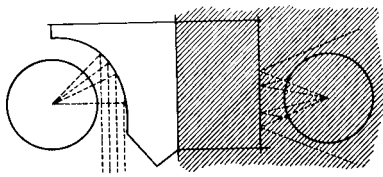
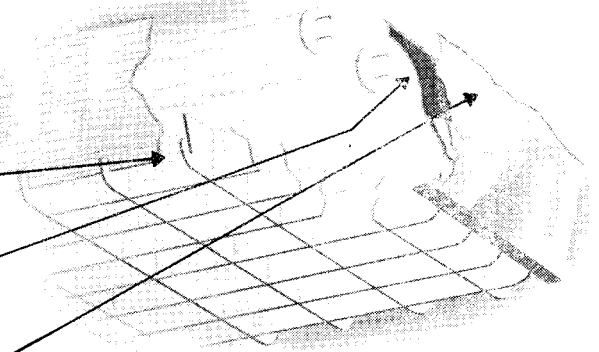

SKYLITE CONVENTIONAL

The Smithcraft "SKYLITE" fluorescent fixture combines a beautiful decorative appearance with sound, skillful light engineering. In addition, its strong, rigid housing assures long life. Its louvres are hinged at both ends for easy maintenance. Can be easily and quickly surface mounted or pendant hung—individually or in continuous rows—with exclusive Smithcraft Non-turn Stem Lock Canopy Set.

From the seven skillfully designed Smithcraft models you can select one which will match any interior ... provide ideal fluorescent lighting for your next installation. Write for catalog.

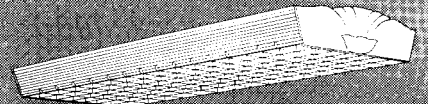
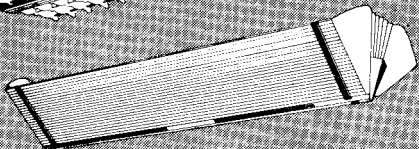
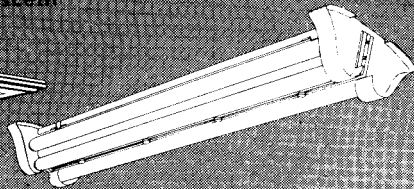
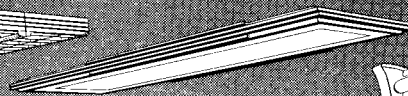
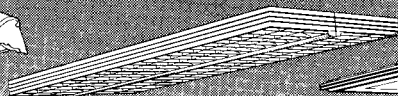
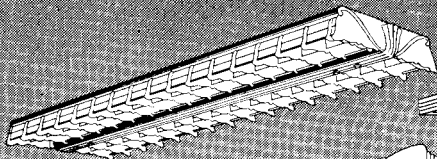

Smithcraft
SMITHCRAFT LIGHTING DIVISION
Chelsea 30, Massachusetts

CONTEMPORARY SHOPS in the United States

By EMRICH NICHOLSON

Second and Enlarged Edition, 1946

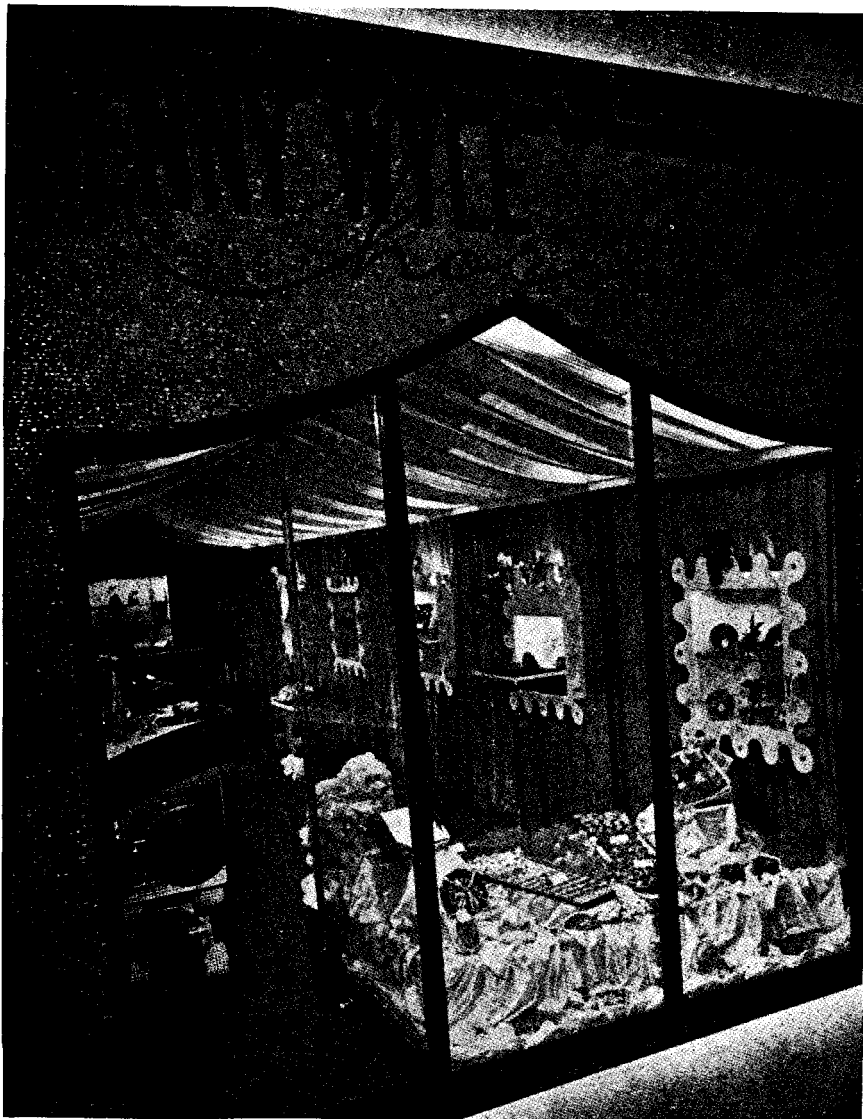

CONTEMPORARY SHOPS IN THE UNITED STATES was published to supply an insistent demand. Many merchants — many designers — many people deeply interested in modern architecture — knew how much fine work had been done in this field. They demanded a book which should show examples of such work, recently carried through in the United States.

Including the supplement of 24 pages, over 400 illustrations, plans, etc., showing 113 shops, large and small, handling many lines of merchandise, located from coast to coast, designed by 70 leading designers and architects. 216 pages. 8½ by 11. \$10.00

The above book will be mailed postpaid on receipt of price.
Send your order and payment direct to

Book Department, Architectural Record
119 West 40th Street, New York 18, N. Y.

Please send copy(s) CONTEMPORARY SHOPS IN THE UNITED STATES
Money order or check for \$ enclosed. (Add 2% Sales Tax for New York City delivery.....\$10.20)

Name.....

Address.....

City.....Zone.....State.....

A.R.-5-47

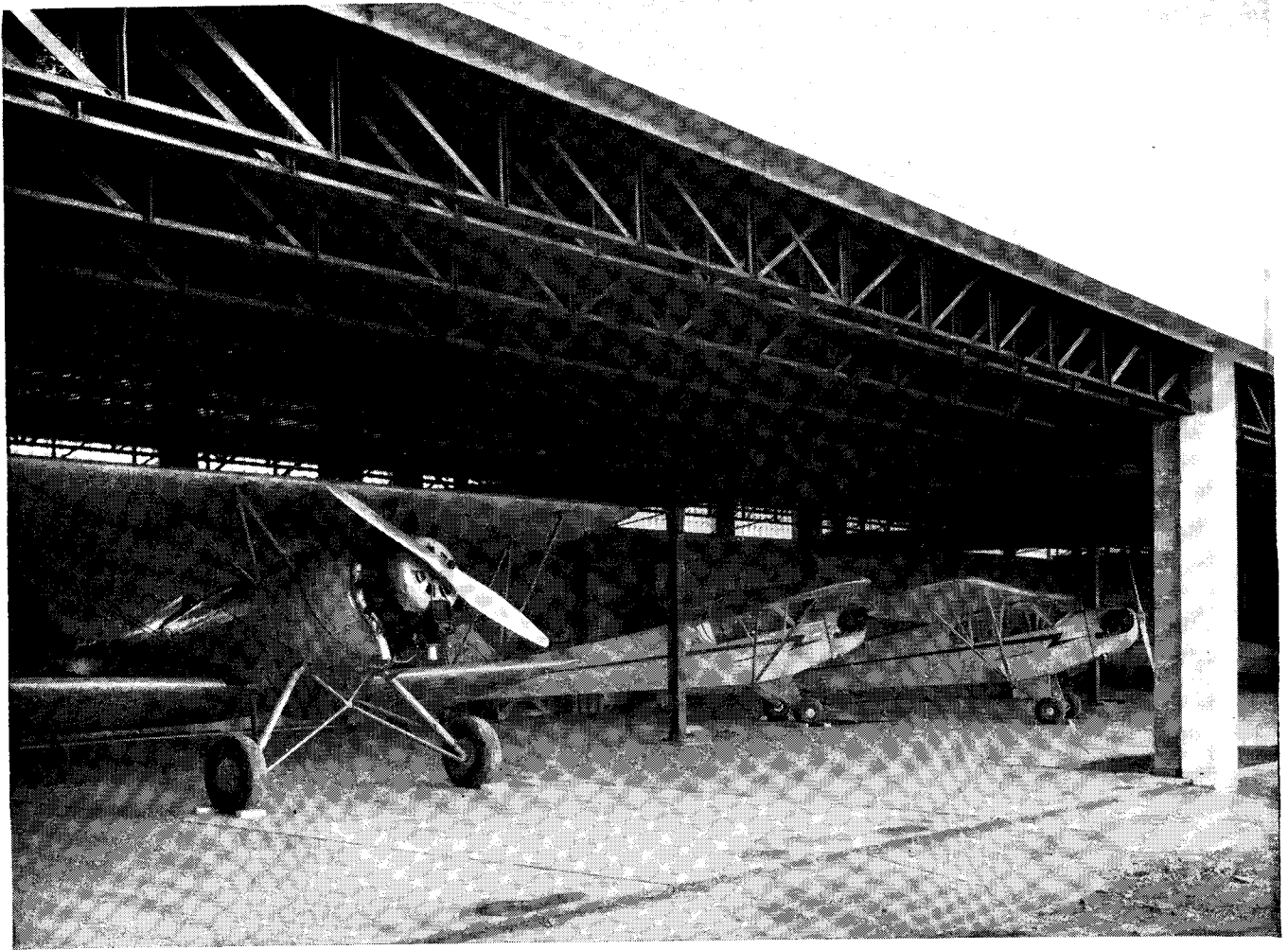

Open-Web Joists in airplane hangar

Designed by Jos. W. Hoover, Architect, and built recently for the Graham Aviation Company, this 42 ft x 224 ft hangar at Allegheny County Airport, Pittsburgh, accommodates up to ten planes of the type used in flight-training. And because Bethlehem Longspan Joists were used in its construction, the floor area is virtually column-free, thus permitting easy movement of the planes in the hangar when being parked or serviced.

Because they eliminate columns in floor areas up to 64 ft across, Bethlehem Longspan Joists are excellent for supporting the roofs of airport hangars and other light-occupancy structures. Besides, Longspans have other worth-while advantages: They

reduce the need for pilasters. They permit pipes, conduits and ducts to be run through the open webs. They accommodate plaster ceilings.

And that's not all. Longspans are time-savers, too. Like Standard Bethlehem Open-Web Joists they come completely fabricated and clearly marked, ready for use without falsework.

Send for our new 36-page joist catalog. It gives complete information about Bethlehem Open-Web Joists, includes design data and shows typical installations. Ask the nearest Bethlehem district office for your copy, or write to us at Bethlehem, Pa.

BETHLEHEM STEEL COMPANY, BETHLEHEM, PA.
On the Pacific Coast Bethlehem products are sold by
Bethlehem Pacific Coast Steel Corporation



★ BETHLEHEM OPEN-WEB JOISTS

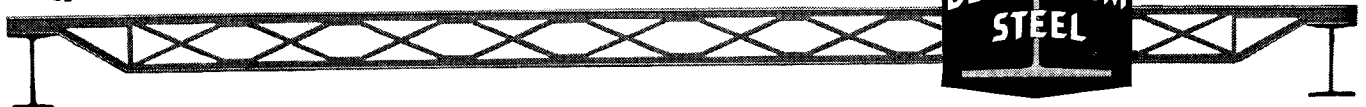

"OUR BIG PUSH for 1947 will be RENTAL HOUSING.."

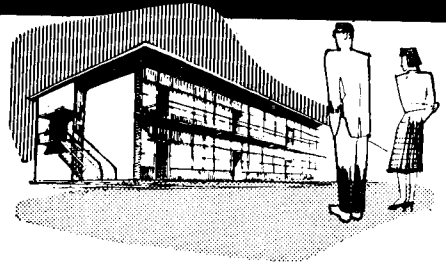

More Emphasis Needed on Rental Housing, Symposium by Leading Architects Shows

As the soundest method of meeting the needs and preferences of World War II veterans, greater emphasis on rental housing than indicated by present government policy is advanced in a symposium by leaders of the architectural profession in the current issue of *Architectural Record*.

The symposium indicates that the \$6000 for-sale house, which has been emphasized and encouraged by the Federal Housing Administration, is not realistic in their relation to the cost of production and operation.

Architect Says Rental Housing Best Solution
SAYS VETS NEED RENTAL HOUSING
 Editor Asserts \$6,000 Home Won't Satisfy All
Most Vets Want Rental Housing
 As the soundest method of meeting the needs and preferences of World War II veterans, greater emphasis on rental housing than indicated by present government policy is advanced in a symposium by leaders of the architectural profession in the current issue of *Architectural Record*.

"Our big push for 1947 will be rental housing. It is clear that what the veterans need most are rental units. More of these must be built. In cooperation with financial institutions and industry, we are continuing to seek other aids that will encourage builders to produce more rental housing."

FRANK R. CREEDON
 Federal Housing Expediter

In May just a year ago *Architectural Record* carried a 24-page editorial presentation of rental housing as offering the right solution for a large share of the housing shortage. The Record's editors had felt from the start that this was one of the serious deficiencies in the Veterans' Emergency Housing Program.

This feature article was based on a nation-wide check of informed opinion, including a canvass of veterans' organizations. It was soon apparent that *minimum-cost houses to be built for sale* did not represent what many veterans and other citizens were seeking — nor what they could logically afford.

Three outstanding points in the Record presentation were:

1. Rental housing in the form of apartments, and garden-type apartments specifically, could better house

a large number of families — in shorter time and at lower cost.

2. This type of construction would bring into the housing program the design talents of architects and engineers — and the invaluable construction knowledge of large contracting organizations — more fully than would any other type of building.

3. Apartment construction — generally employing a higher quality and wider variety of materials and equipment — would mean the utilization of manufacturing facilities otherwise idle in an exclusively minimum-cost housing program.

The Record's apartment proposal was submitted to Government authorities; reprints of the editorial presentation were put into the hands of Congressmen, veterans', trade, and labor organizations. It was promptly picked up and endorsed by major newspapers throughout the country.

The Record's proposal became the core of the veterans' housing program!

The continued development of this idea was shown in the February and March 1947 issues of the Record.

Feature articles on land use, zoning problems, financing both low-rent suburban and luxury city apartments — by private and government spokesmen — were supported by opinions of authorities like Mr. Creedon. The result was another editorial presentation — geared to the needs of Record readers and the interests of Record advertisers — in which the "what, why and how" of a vital current problem were fully treated. The "how" was amplified by a detailed Building Types study of apartment building design and construction in the March issue.

* * *

Record readers and advertisers expect this kind of editorial treatment in this publication. They see typical editorial acumen in the "what and why" of such a problem; in the "how" they see the continuous evidence that the Record's editors are themselves architects and engineers.

That is why the Record has more architect and engineer circulation than any other business paper. This is the practical workbook of the men who select and specify building materials, equipment, furnishings and services. This is the market-place in which to keep your story told.

ARCHITECTURAL RECORD

119 WEST 40TH STREET, NEW YORK 18

OTHER DODGE SERVICES

DODGE REPORTS AND DODGE STATISTICAL RESEARCH SERVICE
 SWEET'S FILES REAL ESTATE RECORD & BUILDERS' GUIDE
 HOME OWNERS' CATALOGS THE DENVER DAILY JOURNAL
 CHICAGO CONSTRUCTION NEWS DAILY PACIFIC BUILDER

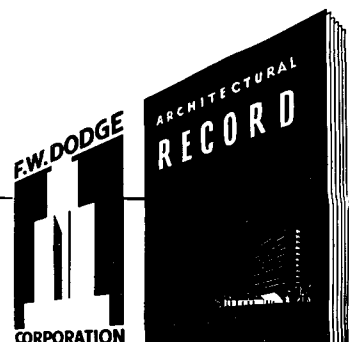

From the cradle to the grave...



**HERMAN NELSON PRODUCTS
SERVE MILLIONS IN AMERICA**

FROM hospitals where babies first see the light of day . . . to funeral homes from where men go to their final resting place . . . Herman Nelson Products serve millions every day by maintaining comfortable and healthy air conditions.

Because the average man spends about 80 per cent of his entire lifetime indoors, it is important that all buildings in which he goes to school, works and plays be properly heated and ventilated. For over 40 years, The Herman Nelson Corporation has been building quality heating and ventilating equipment for public,



**GEORGE R. WHITE MEMORIAL BUILDING
MASSACHUSETTS GENERAL HOSPITAL**
*Architect: Coolidge, Shepley, Bulfinch and Abbott—Boston, Mass.
Engineer: Office of Hollis French—Boston, Mass.
Contractor: James S. Cassidy, Inc.—Cambridge, Mass.*

industrial and commercial buildings. Leading Architects, Engineers and Contractors, as well as Owners, know that the use of Herman Nelson Products will assure maintenance of desired air conditions.



THE HERMAN NELSON CORPORATION

Since 1906 Manufacturers of Quality Heating and Ventilating Products

MOLINE, ILLINOIS

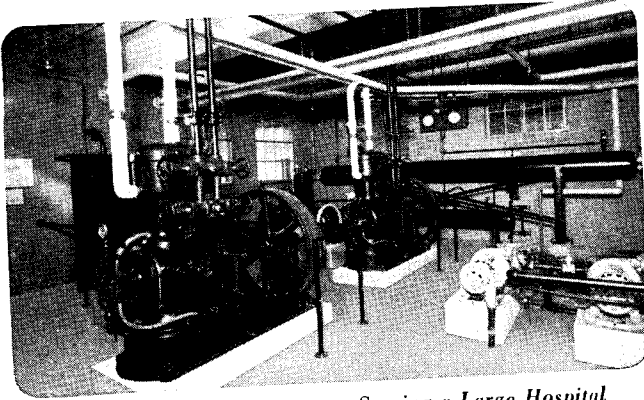

Frick Ammonia Compressors Serving a Large Hospital

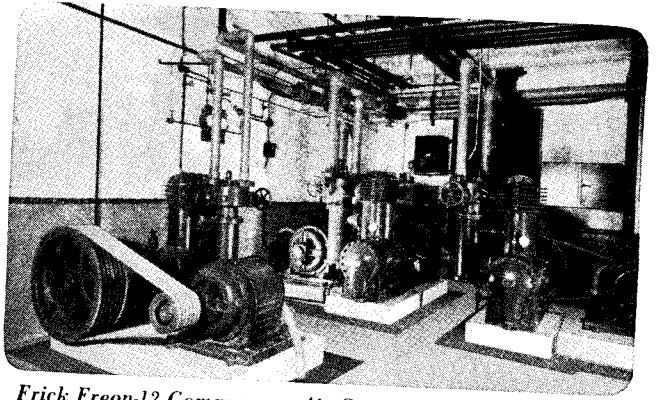

Frick Freon-12 Compressors Air Condition an Office Building

Whether You Need Ammonia or Freon-12 Equipment, You Get What You Want with



Refrigeration

As builders of both ammonia and low-pressure systems, we are in an unbiased position in filling your requirements.

For the ultimate in satisfactory cooling equipment, put your problems up to the nearest Frick Branch or Distributor.

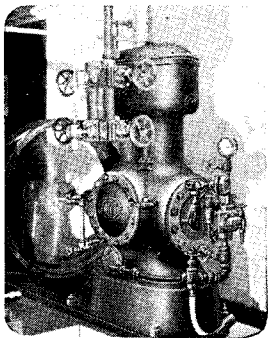

Frick Ammonia Compressor

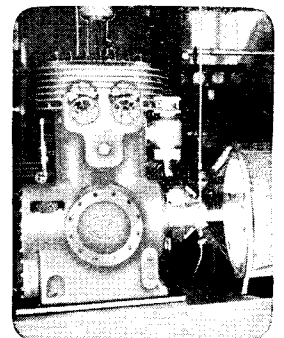

Frick Freon-12 Compressor

DOUBLE FEATURE

Double

FOR THE MONEY

See pages 8-9

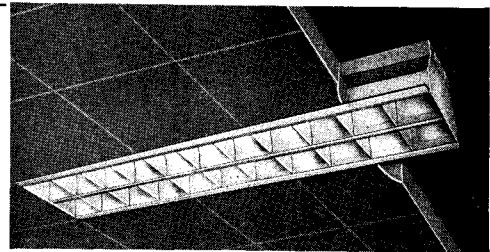

COFFER or TROFFER

Engineered by Century

Spaced in individual 50" sections or run in continuous bands, this versatile two lamp 40 watt fluorescent unit (4 ft.) has superior lighting qualities.

HIGH EFFICIENCY and uniform light distribution from specular Alzak reflectors.

LOW SURFACE BRIGHTNESS without glare through louvre spacing and reflector design.

EASY MAINTENANCE ACCESS provided by open construction and hinged louvre frame.

Specify and Order by Catalogue Number: F248AF

CENTURY lighting equipment is ENGINEERED lighting equipment

CENTURY LIGHTING, INC.

419 WEST 55TH STREET 626 NO. ROBERTSON BLVD.
NEW YORK 19 LOS ANGELES 46

COMPACTNESS and QUALITY...

You get both with these new *Western Electric* Loudspeakers

- ★ They fit in small spaces
- ★ They're easily installed
- ★ They reproduce music with full, natural tone

728 B SPEAKER

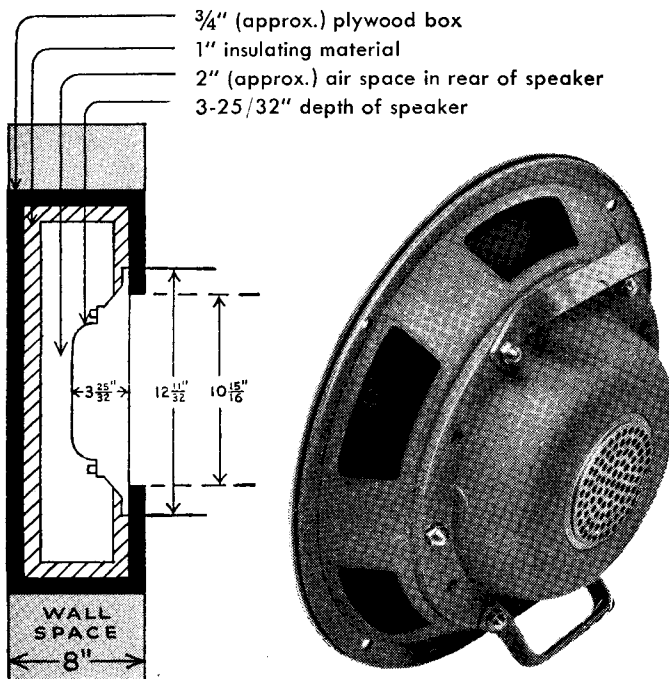

The latest technical advances are incorporated in this speaker to provide reproduction that's amazing in its realism. Only 12-11/32" in overall diameter, it requires but a 3 cubic foot enclosure with a 10-15/16" baffle hole.

755 A SPEAKER

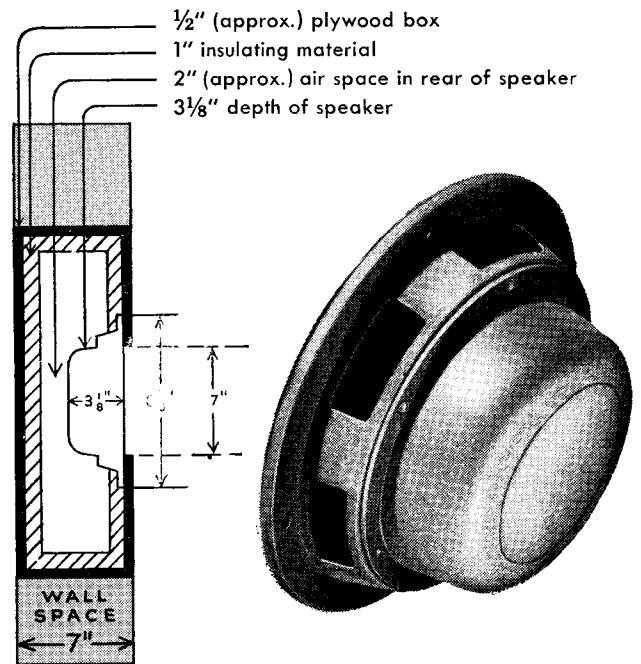

Weighing but 4 3/4 lbs., with an overall diameter of 8-3/8", this speaker needs only a 2 cu. ft. space with a 7" baffle hole. Its low cost and high quality of reproduction prove that good things do come in small packages.

In the past, high quality loudspeakers were large in size and required extra wall space for installation . . . small, compact speakers lacked quality. Now, Western Electric offers two new loudspeakers that are so compact they require a mounting space only 7 or 8 inches deep to bring out the full quality inherent in them.

They're easily box-mounted or installed right in walls or ceilings. And their quality of reproduction gives you the type of sound system you want. Their wide frequency response means they reproduce more of the music . . . more naturally!

For complete information, contact the nearest representative of the Graybar Electric Company, distributors of Western Electric sound systems, or write Graybar, 420 Lexington Ave., New York 17, N. Y.



- Quality Counts -

The Hallmark
OF TOMORROW'S HOME

SOSS

INVISIBLE HINGES

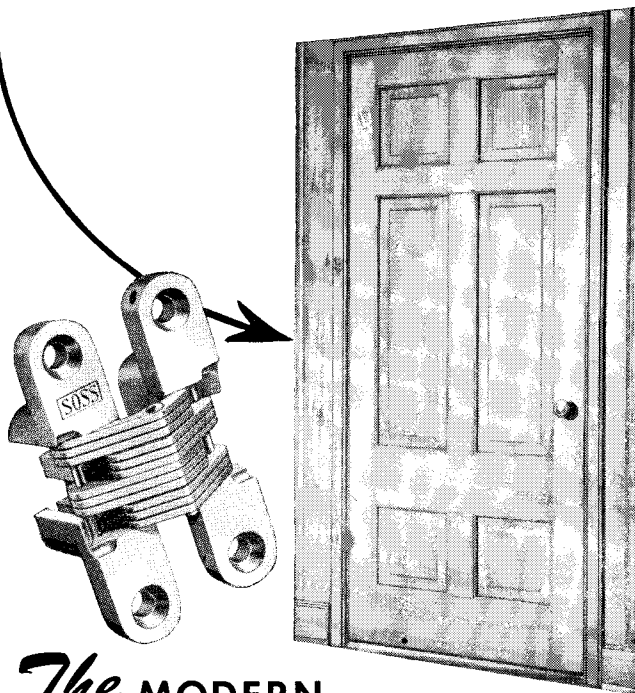

The MODERN...
DIFFERENT "out of sight" HINGE

"This house has personality! There is something different and distinctive about it!" Many times people make just such remarks when looking at a home equipped with SOSS INVISIBLE HINGES—for these hinges when installed are completely concealed.

It is obvious why SOSS hinges impart a distinguished personality to any home. For one thing they permit the use of flush surfaces for doors, panels and cupboards which are a feature of modern streamlined design. Furthermore they eliminate surfaces marred by unsightly protruding butts. Your clients will commend you for suggesting these modern hinges.

Write for SOSS "Blue-Print Catalog" giving full details of the many applications of this modern hinge. Free on request.

SOSS MANUFACTURING COMPANY

21765 HOOVER ROAD • DETROIT 13, MICHIGAN



HYDROTHERM

AUTOMATIC GAS FIRED
CENTRAL HEATING PLANT

for HOT WATER HEATED HOMES

MORE heat
from
LESS space

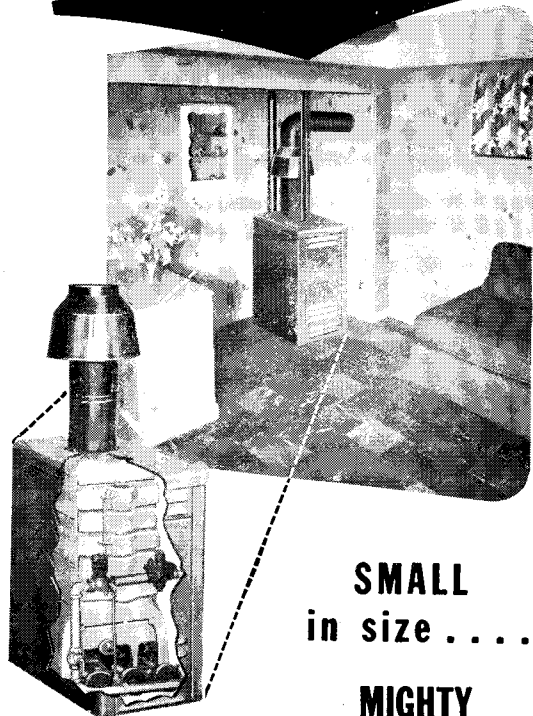

SMALL
in size

MIGHTY
in performance!

- LONG-LIFE CAST IRON CONSTRUCTION
- LIGHTWEIGHT, EASY INSTALLATION
- HIGHLY EFFICIENT PATENTED DESIGN
- IDEAL FOR PANEL AND RADIANT HEATING
- APPROVED BY AMERICAN GAS ASSOCIATION
- SPACE-SAVER IN BASEMENT, PLAYROOM

WRITE FOR NEW DESCRIPTIVE BOOKLET AR-5

HOOK & ACKERMAN, Inc.
18 EAST 41st STREET, NEW YORK, N. Y.

For competent, authoritative assistance... *Quick*

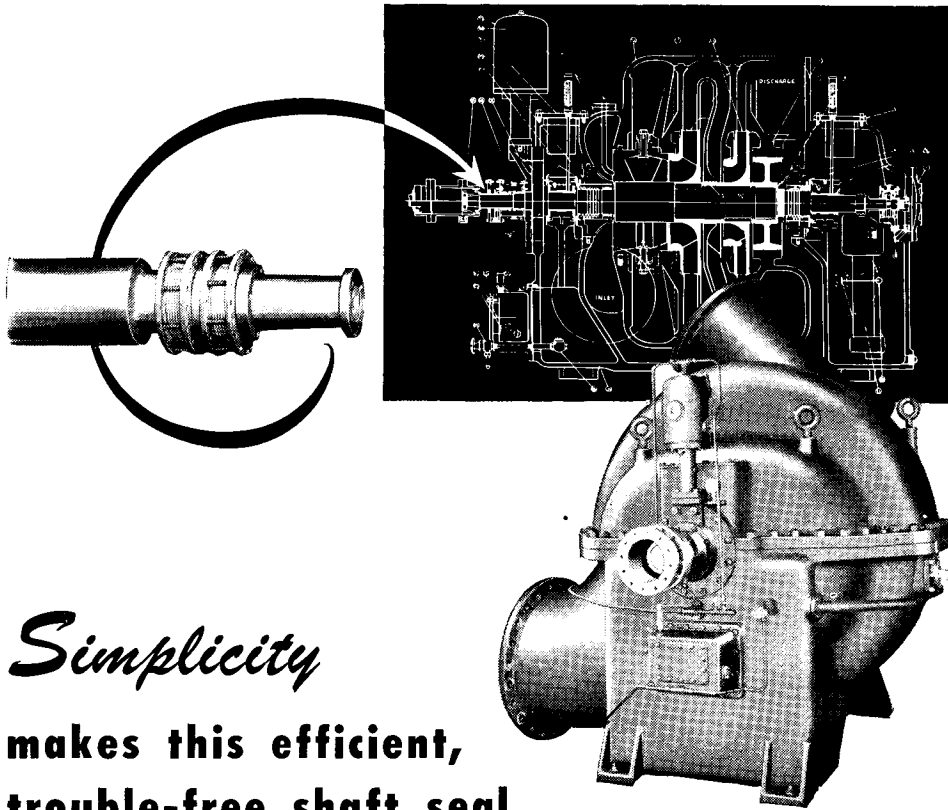

Simplicity
makes this efficient,
trouble-free shaft seal

DIFFERENT

In the York Allis-Chalmers Turbo Compressor, leak-proof sealing is secured through impingement of stationary carbon rings on either side of a "Meehanite" seal ring which rotates with the shaft. The carbon rings are enclosed in nonferrous bellows secured to the compressor housing, and contact with the seal ring is maintained by spring pressure. Oil circulated by the main oil pump lubricates the rotating faces of the shaft seal and carries off

the heat of friction. A gravity tank maintains an oil head on the seal when the compressor is idle. Since this high efficiency seal has few parts to get out of order, maintenance is negligible.

This unusual shaft seal is but one of the many exclusive design features of the York Turbo Compressor and is representative of the thoroughness of York engineering throughout its complete line of refrigeration and air conditioning equipment. York Corporation, York, Pa.

York-trained refrigeration and air conditioning engineers complement York mechanical advancements and the completeness of the York range of equipment, provide architects, consultants and contractors with assistance in planning, purchasing, installing and operating mechanical cooling systems.

In the Cleveland Area, for example, District Manager Yoder, and fourteen sales engineers devote their full time to the problems of York customers in this district.



H. S. Yoder,
District Manager

C. J. Schurman
Sales Manager

Assisted by:
L. W. Cordrey
L. R. Craig
J. O. Currie
R. W. Geltz
C. G. Gillespie
F. J. Goff
W. P. Kohn
L. Lewis
L. P. Quinlivan
J. A. Schurman
G. O. Weddell
A. P. Wolff
D. J. Wood

YORK *Refrigeration and
Air Conditioning*



HEADQUARTERS FOR MECHANICAL COOLING SINCE 1885



As new and modern
today as 12 years ago . . .

Here is an illustration of an interesting combination of SEAPORCEL porcelain enamel in various colors: Gray enamel facia relieved with stenciled spandrels depicting the S.S. QUEEN MARY in four colors.

From 1935 to 1947 this architectural porcelain front has proved color fast and durable regardless of weather conditions.

It Makes Sense

When you specify SEAPORCEL* you are assured of the finest materials, skilled craftsmanship and the services of a production and engineering organization of recognized ability.

There are a few areas in which Seaporcel Porcelain Metals, Inc., is not represented. Inquiries from interested agents are invited.

WRITE TODAY for our catalogue describing details of customary design and examples of completed work.

*Seaporcel (Reg. U. S. Pat. Off.) is a ceramic coating fused into its metal base at 1550 degrees F.

SEAPORCEL PORCELAIN METALS, INC.

Formerly Porcelain Metals, Inc.

28-02 Borden Avenue, Long Island City 1, N. Y.

Seaporcel

"Member Porcelain Enamel Institute, Inc."

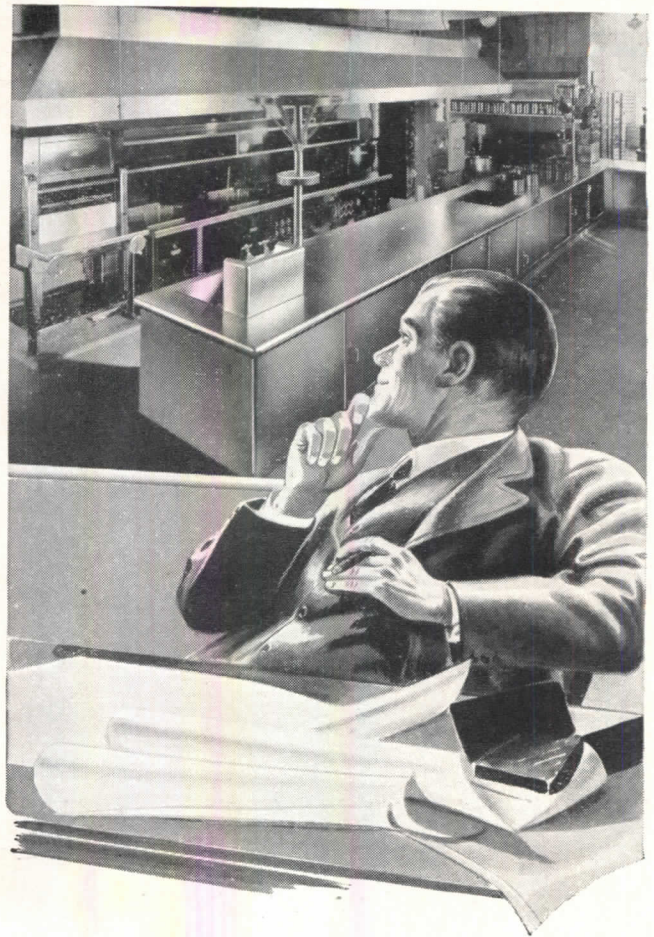

His Thoughts Must Include the Kitchen

Whether the plans are for hotel, hospital, institution or restaurant, the food preparation and service are all important.

A century of experience has shown us that cost-cutting involves more than just equipment.

Layout is of prime importance.

In any case, long range study and planning are essential.

The John Van Range Co.

EQUIPMENT FOR THE PREPARATION AND SERVING OF FOOD

DIVISION OF THE EDWARDS MANUFACTURING CO.

Branches in Principal Cities

429 CULVERT STREET

CINCINNATI 2, O.

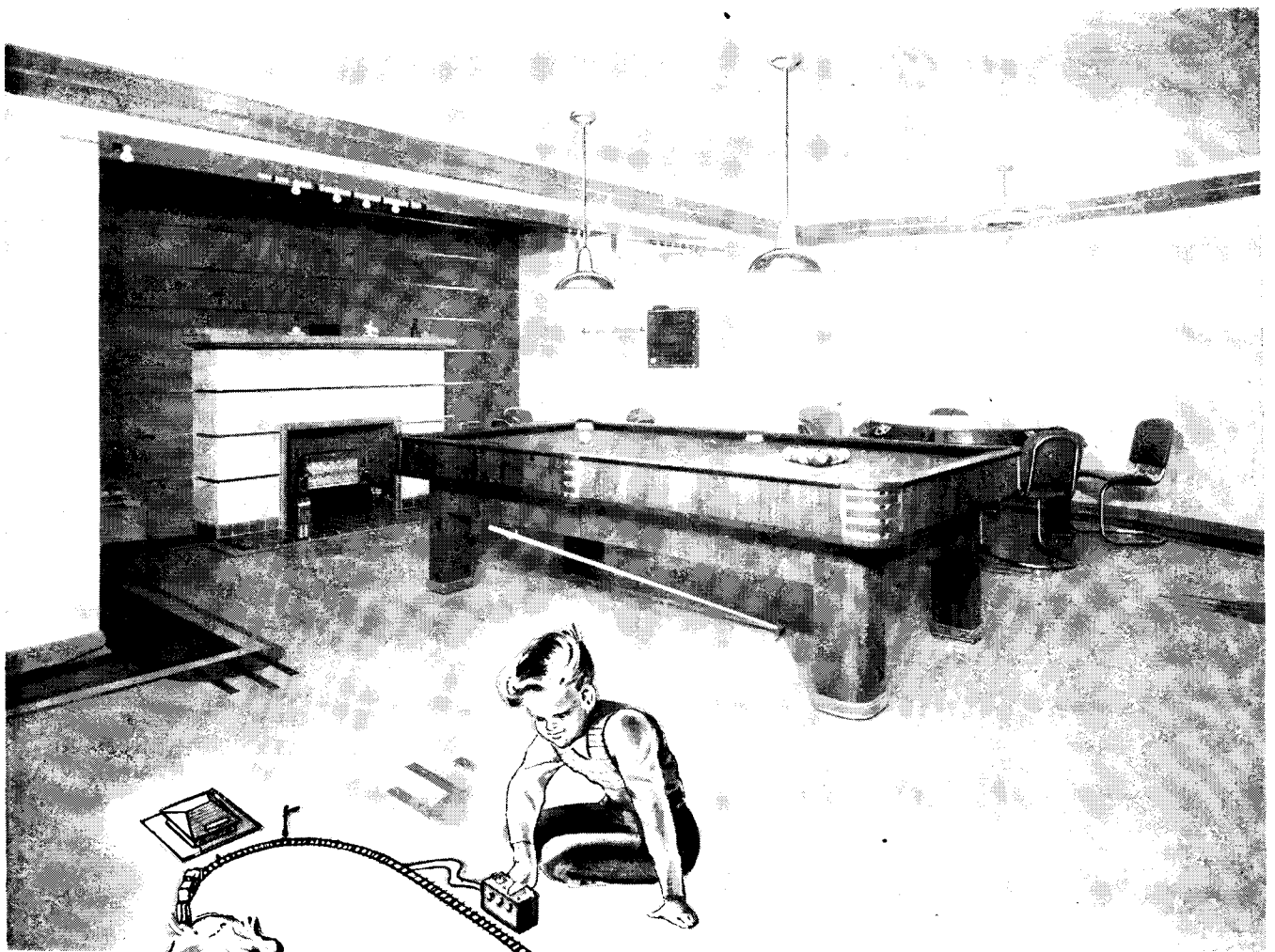

*It's fun to play
in the basement*
when the floor is so cozy and dry

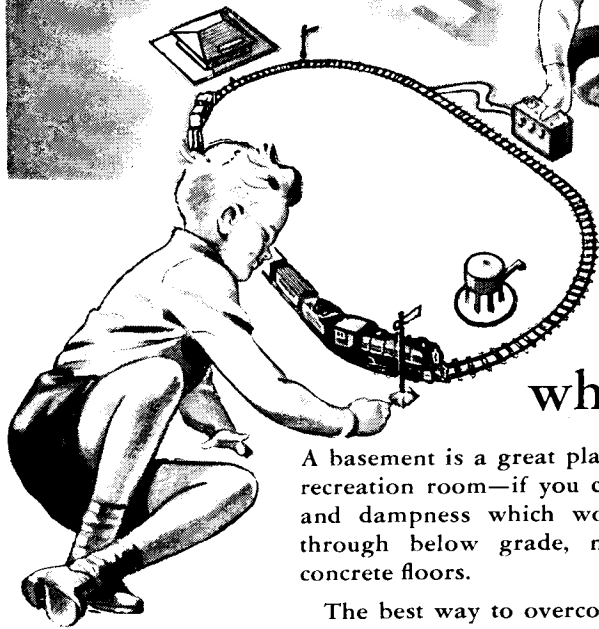

A basement is a great place for the family recreation room—if you can beat the cold and dampness which works its way up through below grade, non-waterproofed concrete floors.

The best way to overcome this threat to family fun and health—and provide your clients with handsome, easily maintained, all-purpose floors in the bargain—is to specify Tile-TeX Asphalt Tile. Here's a flooring that's highly moisture-resistant. There is nothing used in its composition which might cause it to rot or disintegrate. Naturally, floors of Tile-TeX are cozy and dry—safer,

cleaner play surfaces for young children.

What's more, Tile-TeX makes a smart-looking recreation room floor. It's available in a wide range of bright, stimulating game room colors, plus decorative accessories—which make possible an endless variety of designs. Its smooth, closely textured surface cleans easily—stubbornly resists stains and scars—and is comfortable under foot. Most important, too, is the tough ruggedness of Tile-TeX that gives it the extra value of long life.

Please write us if we can help you in any way with problems of asphalt tile floor design.

THE TILE-TEX CO., INC., CHICAGO HEIGHTS, ILL.
Sales Offices: Chicago, New York, Los Angeles and New Orleans



TILE • TEX ASPHALT TILE

Announcing

Swartwout's New
Powered Roof Ventilator
The
Ject-O-Valve

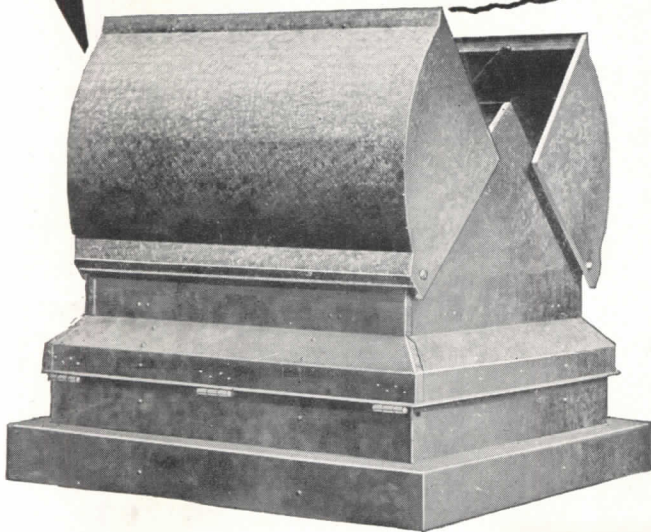

Powerful...Economical...
Constructed to Stand Long, Hard Use

For your smoke, fume, dust or heat problems that only *power* elimination will solve . . . this high velocity ventilator has many values for your consideration. . . .

Ject-O-Valve is the "straight-through" type. The powerful blast from its scientifically designed propeller holds top sections open, sweeps aside all weather, forces unwanted elements into the outer atmosphere. Top closes weather tight when motor stops.

Carefully engineered in five sizes . . . and powered by motors and propeller type fans of varying ratings to give you a selection of 14 different capacities. Write for Ject-O-Valve Bulletin 323.

The Swartwout Company
18639 EUCLID AVENUE
CLEVELAND 12, OHIO

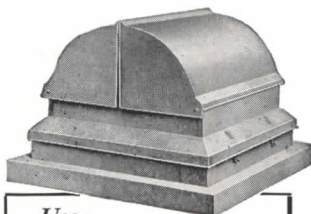

Use
Ject-O-Valve
over pouring floors,
vats, furnaces,
soaking pits, etc.

Swartwout
Controlled Air Circulation

EQUIPMENT FOR EFFECTIVE ECONOMICAL
VENTILATION OF INDUSTRIAL BUILDINGS

KIMBERLY

Carbo-weld

DRAWING PENCILS

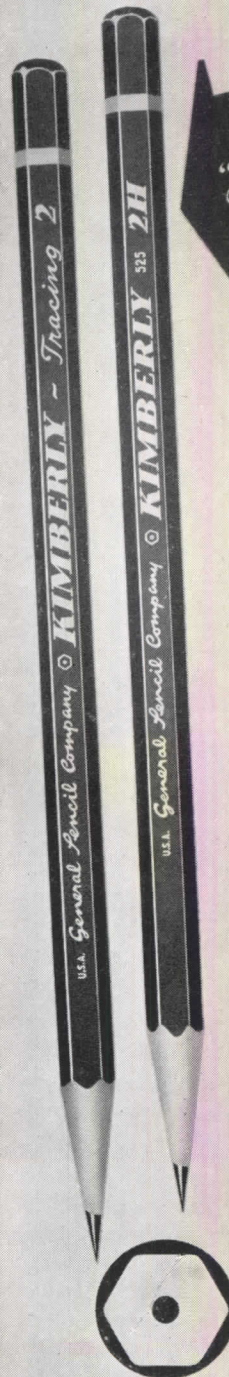

What is KIMBERLY
"BUILT-IN-QUALITY"?

It is the fine grade of graphite ground to rich smoothness, accurately blended into 22 degrees and bound to a selected grade of wood by Carbo-Weld process. This is the "built-in-quality" that makes KIMBERLY a better drawing pencil. A pencil with *strength* and *smoothness*, making work easier and more *economical* with less sharpenings. Their *uniformity* in every degree and lead density creates a clean sharp line for reproduction. And you pay no more for this *finer, better* drawing pencil.

22 ACCURATE DEGREES

Drawing 6B to 9H, Tracing 1-2-3-4 and Extra B. layout pencil for artists.

Write to Dept. R for free sample mentioning the degree. Buy them from your dealer or if unavailable send us \$1.00 for a prepaid trial dozen of your favorite degree or assortment.

(This offer good only within U.S.A.)

Makers of Fine Pencils since 1889
General Pencil Company

67-73 FLEET STREET



JERSEY CITY 6, N. J.

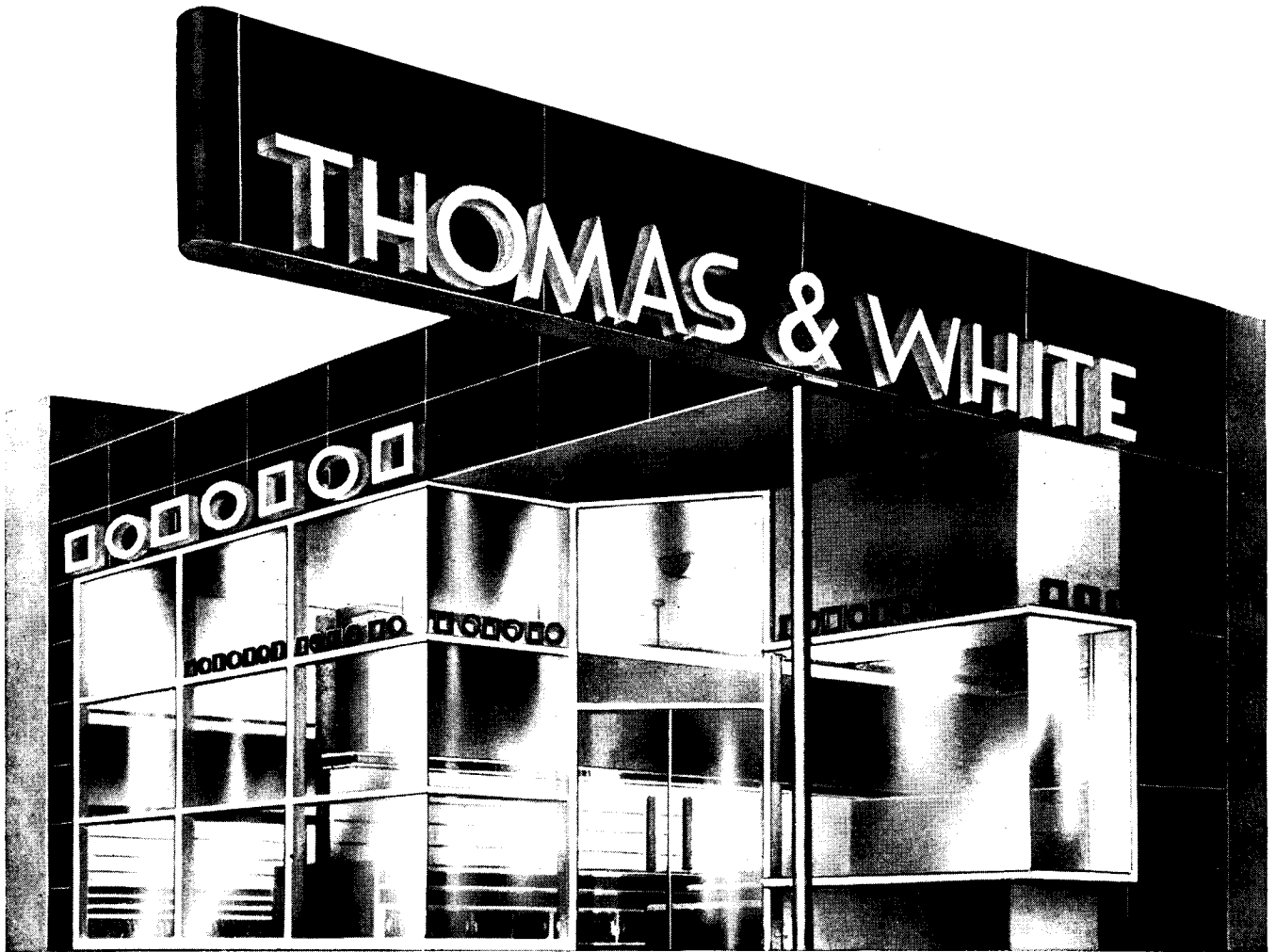

Exposing the Store to Sales

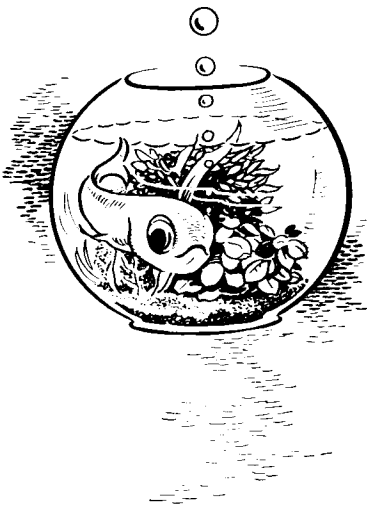

It's like doing business in a goldfish bowl when the store is equipped with an all glass, open-view front. Revealing the light, color and activity within, it attracts instant attention, creates active interest in what the store has to offer.

For additional selling power, the new fronts feature alluring contours and artfully devised entrance areas. But modern design demands modern construction. That's why leading architects choose Brasco, in stainless steel or aluminum, for authentic interpretation of their advanced ideas.

The Brasco line is engineered as a *unit*—related strength is built into every member so that the entire front is a rugged, harmonious whole. Patented features provide ease of installation and adequate glass protection. It assures your clients of sound construction plus beauty with an eye for business.

A COMPLETE LINE FOR EVERY DESIGN



BRASCO MANUFACTURING CO.
HARVEY • (Chicago Suburb) • ILLINOIS

National Distribution Assures Effective Installation

H&H FLUSH RECEPTACLES

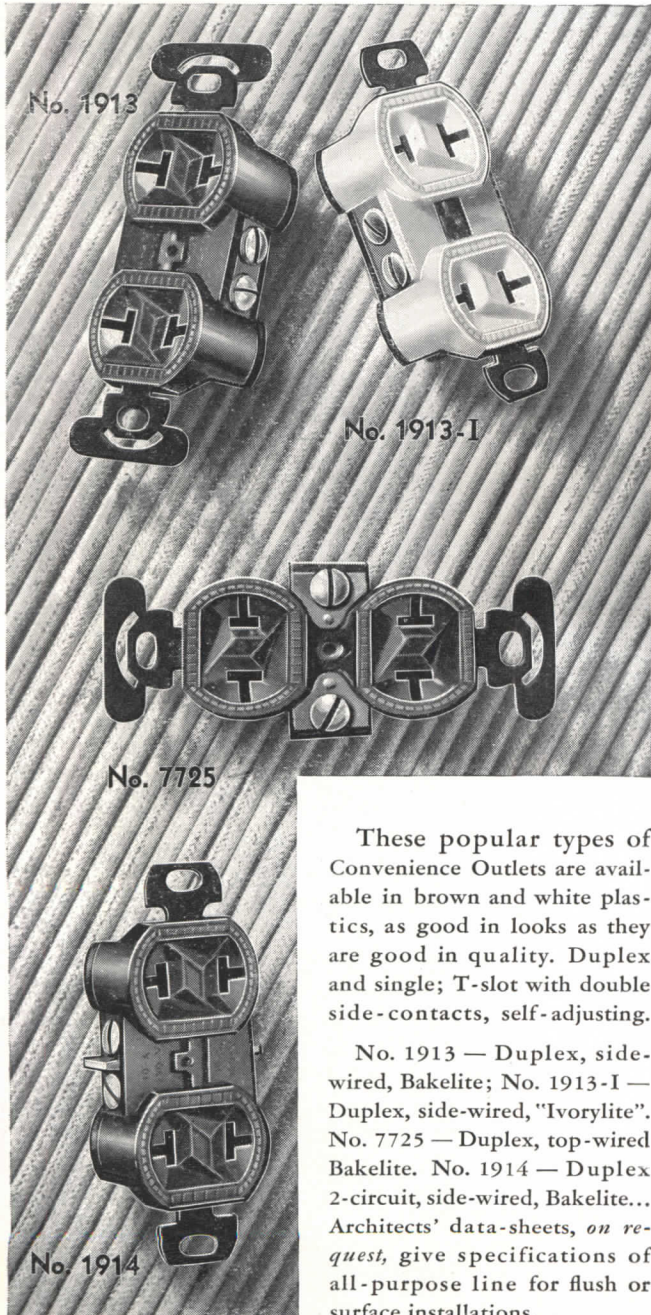

These popular types of Convenience Outlets are available in brown and white plastics, as good in looks as they are good in quality. Duplex and single; T-slot with double side-contacts, self-adjusting.

No. 1913 — Duplex, side-wired, Bakelite; No. 1913-I — Duplex, side-wired, "Ivorylite". No. 7725 — Duplex, top-wired Bakelite. No. 1914 — Duplex 2-circuit, side-wired, Bakelite... Architects' data-sheets, *on request*, give specifications of all-purpose line for flush or surface installations.

HART & HEGEMAN DIVISION

**ARROW-HART & HEGEMAN ELECTRIC
COMPANY, HARTFORD 6, CONN., U.S.A.**

How **ADJUSTABLE** air diffusers
increase the efficiency
of supply air distribution

Kno-Draft Adjustable Diffusers offer all the advantages of draftless air diffusion plus fast system balancing and air pattern control

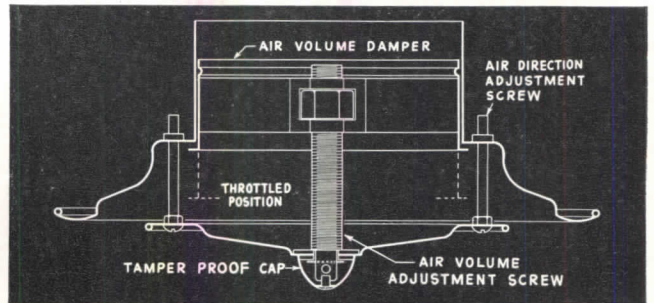

Pat. & Pat. Pending

Fast System Balancing: Volume damper regulates the air outlet aperture uniformly without affecting the outlet velocity or diffusion pattern.

Positive Air Pattern Control: Air direction adjustment affords any angle of air discharge from vertical to horizontal needed to accommodate ceiling heights, individual or seasonal requirements. It can expel chilled air parallel to the ceiling or eject heated air downward to prevent stratification.

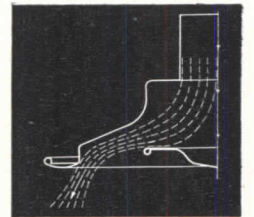
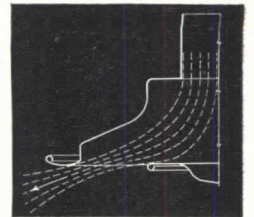
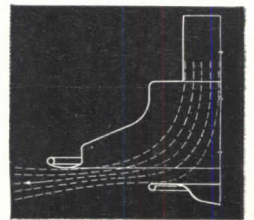

Specify Kno-Draft Adjustable Air Diffusers for better mixing control of room and supply air, more uniform temperatures throughout the occupied zone and noiseless, draftless air distribution.

Send for **FREE handbook** containing sketches, charts, dimension prints and instructive text that simplify the selection and installation of air diffusers. For your copy, please write Dept. S-13, on company letterhead.

W. B. CONNOR ENGINEERING CORP.
AIR DIFFUSION AIR PURIFICATION AIR RECOVERY

112 East 32nd Street



New York 16, N. Y.

IN CANADA: Douglas Engineering Co., Ltd., 1405 Bishop St., Montreal 25, P. Q.

Why is Duraplastic Cement being specified more and more

By

**Architects, engineers, contractors, dealers,
ready-mix operators and concrete products makers**

For

**Paving, sidewalks, foundations, floors and walls—
plaster, stucco, pump-crete, gunite and slip-form work—
concrete block, pipe, drain-tile and other products**

?

ATLAS DURAPLASTIC

AIR-ENTRAINING PORTLAND CEMENT

MAKES BETTER CONCRETE AT NO EXTRA COST

*Here are 5
Quick Answers:*

1. Complies with ASTM and Federal Specifications. Provides the proper amount of entrained air needed for satisfactory field performance.
2. No extra cost. Sells at the same price as regular cement. Calls for no additional materials.
3. Better concrete. Makes concrete more workable, more plastic and more uniform.
4. More durable concrete. Fortifies the concrete against freezing and thawing weather. Renders paving concrete highly resistant to scaling action of de-icing salts.
5. Makes better concrete block. Reduces breakage, improves appearance, lowers water absorption and generally increases strength.

Send for further information. Write Universal Atlas Cement Company, (United States Steel Corporation Subsidiary), Chrysler Building, New York 17, N. Y.

OFFICES:

Albany, Birmingham, Boston, Chicago, Cleveland, Dayton, Des Moines, Duluth, Kansas City, Minneapolis, New York, Philadelphia, Pittsburgh, St. Louis, Waco.

AR-D-51

TRADE MARK REG.
U. A. C. CO.



"THE THEATRE GUILD ON THE AIR"—Sponsored by U. S. Steel—Sunday Evenings—ABC Network

Weatherproof
HOMASOTE

for DURABILITY and APPEARANCE

Over the past 30 years, letters from hundreds of home owners have repeatedly testified... *Homasote keeps its structural strength, keeps its insulating efficiency, keeps its fine appearance.* This performance record is made possible by the fact that Homasote is in every way a *quality product*... a product combining great structural strength and high insulating value *in one material.*

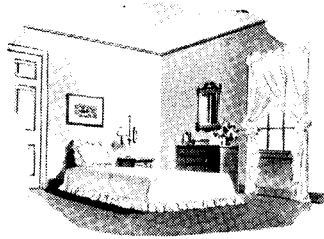

The big sheets of Homasote (up to 8' x 14') add to appearance by eliminating unsightly wall joints and batten strips. Again for good looks—Homasote has a pleasing texture; provides a perfect base for paint or wallpaper. And it is permanently crackproof, too.

For extra strength—as well as insulation—use Homasote for interior and exterior walls, for roof and sidewall sheathings, for subflooring and ceilings. You make a contribution of *permanent value* to any structure when you select Homasote for modernization or new construction.

We invite architects and builders to send for a copy of our new booklet describing some of the many uses for *weatherproof* Homasote. The book gives physical characteristics, performance charts, specification data and application instructions. Write for your copy today.



HOMASOTE COMPANY, Trenton 3, N. J.

Announcing

in a new, revised, 1947 edition . . .

THE MODERN HOUSE

by F. R. S. YORKE, A.R.I.B.A.

This home building classic, with its collection of the finest examples of modern residential architecture, from the United States, England and Continental Europe, has undergone an up-to-the-minute revision.

Photographs, plans and construction details of most recent, most interesting, most successful modern houses have been added, and an entire section is devoted to systems of prefabrication.

FOR ARCHITECTS, STUDENTS, HOME BUILDERS

Although it is illustrated with hundreds of fine photographs, this book is no mere collection of startling pictures. Materials and construction methods are analysed for each house, and preliminary chapters discuss walls, windows, roofs and planning in relation to twentieth century homes. Architects, students and home owners alike will find this new edition of **THE MODERN HOUSE** a source of ideas and inspiration.

Because it is published in England (by the Architectural Press) under severe manufacturing difficulties, only a limited number of copies of **THE MODERN HOUSE** will be available for some time to come. To make sure of securing your copy, order it now from **ARCHITECTURAL RECORD**, sole distributor, using the coupon below. *Price: \$6.50*



THE ABOVE BOOK WILL BE MAILED POSTPAID ON RECEIPT OF PRICE
 Send your order and payment direct to

Book Department, Architectural Record
 119 West 40th Street, New York 18, N. Y.

Please send _____ copy(s)
THE MODERN HOUSE
 Money order or check for \$ _____ enclosed
 (For N. Y. City Delivery add 2% Sales Tax—\$6.63 in all)

Name
 Address
 City Zone State.....

A.R. 5-47



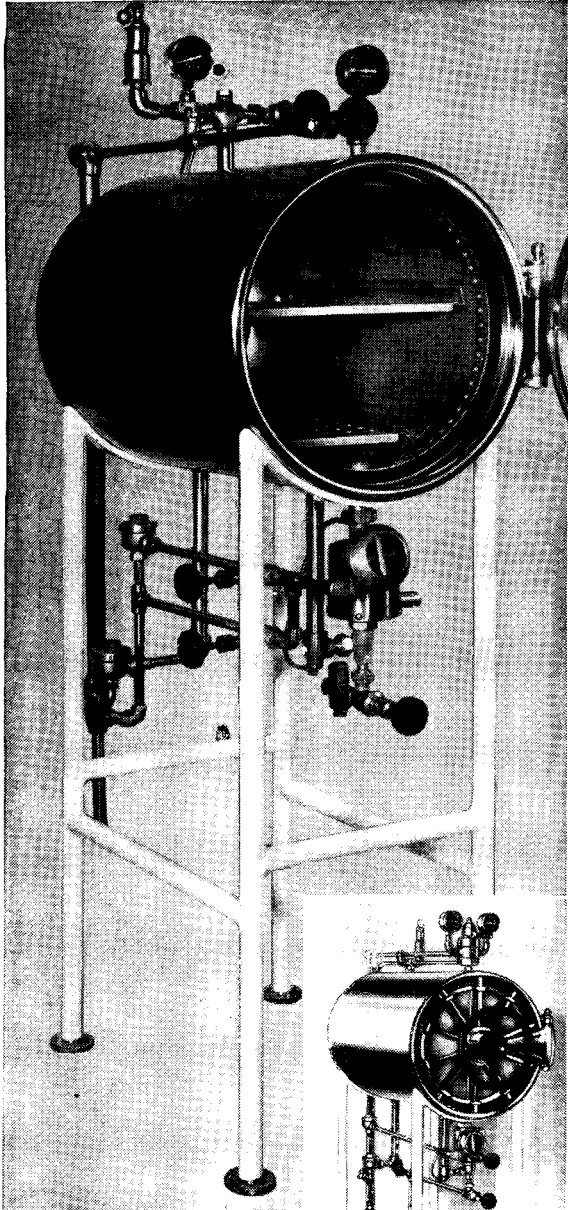

FOR THIS LABORATORY AUTO-CLAVE, as well as for other models, American Sterilizer Company standardizes on solid, corrosion-resistant Monel.

• • •

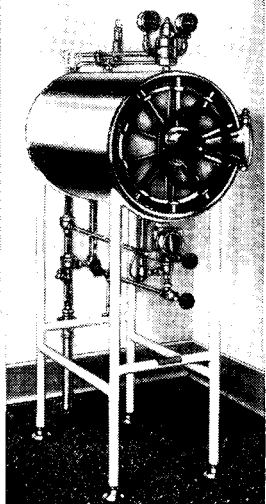

PRESSURE DRESSING AND INSTRUMENT STERILIZER equipped with welded Monel inner chamber and steam jacket, Monel trays and tray racks... for long life under severe conditions.

• • •

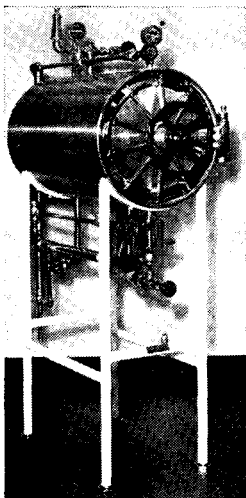

ANOTHER "AMERICAN" MONEL UNIT. The Milk Formula Sterilizer-Disinfector, especially developed to help reduce the threat of cross-infection. Inner chamber, outer jacket, tray and rack, are Monel. Photos courtesy of American Sterilizer Company, Erie, Pa.

SOLID METAL

brings

SOLID ADVANTAGES

to the construction you plan

• For the sterilizer room—as for most major hospital departments—you need remember just *one* metal.

And that is — Monel*.

This rugged Nickel Alloy is more than merely "a rustproof metal."

It's also stronger and tougher than structural steel. It's corrosion resistant... stands up against heat, steam and moisture... against acids, alkalis and a wide range of hospital solutions.

Monel is solid all the way through. Has no surface coating to chip, nothing to peel off or wear away. That's why severe service and constant cleaning never dim Monel's original silvery lustre. Even after years of steady use, Monel equipment has that bright-as-a-dollar look!

For all these reasons, the AMERICAN STERILIZER COMPANY, Erie, Penna., standardizes on Monel for dressing sterilizers and all-purpose sterilizers 12" x 20" and larger.

The solid advantages of Monel add up to long service life... reduced maintenance and repair costs... and performance unsurpassed by any other metal.

As a service to your clients, recommend—

*Reg. U.S. Pat. Off.

MONEL...*

STANDARD METAL OF THE MODERN HOSPITAL



THE INTERNATIONAL NICKEL COMPANY, INC.
67 WALL STREET NEW YORK 5, N. Y.

Murphy Cabranette Kitchens

The only kitchens of their kind in all the world

Welded steel throughout. Exposed surfaces of genuine vitreous porcelain.

Made in 4 widths. Add Utility Cabinets (with shelves) and Implement Cabinets for more storage space. Murphy Cabranette Kitchens never require repainting—upkeep is negligible.

No. 39

Ultra-compact. Storage, deep-bowl sink, electric cookery and refrigerator for efficiency apartment or bachelor suite. 39 inches wide and 23 inches deep, it fits in tiny space.

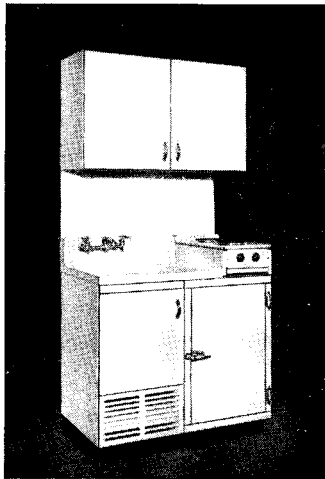

No. 480

Full kitchen convenience in two by four feet. Gas or electric range with oven, electric refrigerator, sink and storage cabinets.

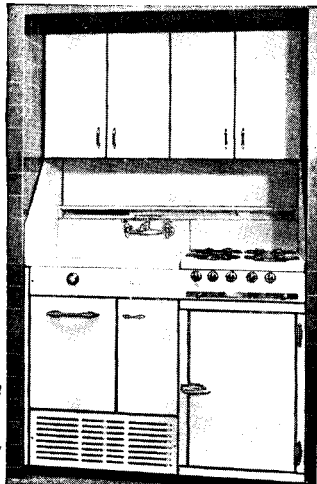

Nos. 60 and 66

Full-sized electric or gas range with oven, full-sized sink, larger refrigerator and more storage space. 60 and 66 inches wide respectively.

Utility and Implement Cabinets

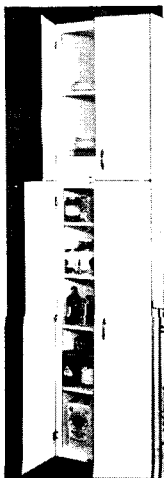

In 15-inch & 21-inch widths.

May be added to all size kitchens.

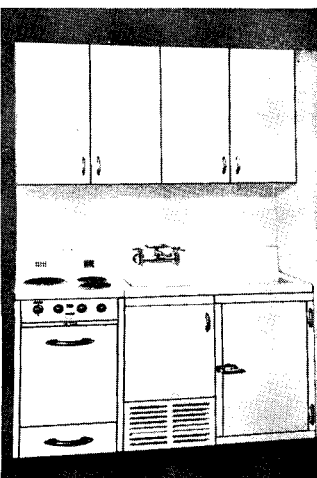

DWYER PRODUCTS CORPORATION
Dept. AR547 Michigan City, Indiana

EMPLOYMENT OPPORTUNITIES AVAILABLE

DESIGNER with excellent references would like exciting varied work with or without possibilities toward partnership. Graduate of University of Minnesota, Masters from Harvard, 3 years as Shipbuilder in Navy, 28 years old, married, 2 children, Veteran, Box 228, ARCHITECTURAL RECORD, 119 W. 40th St., New York 18.

TOP ARCHITECTURAL DESIGNER. Starting salary --- bonus basis. Permanent for right man. Send record of training, experience and samples of design sketches. Box 230, ARCHITECTURAL RECORD, 119 W. 40th St., New York 18.

GENERAL PRACTITIONER for 21 years — Registered 2 States. A.I.A. Member — 48 years old — wants to locate in the Middle West. State working and living conditions, salary. Box 232, ARCHITECTURAL RECORD, 119 W. 40th St., New York 18.

WANTED: Sales representation opportunity. Products and materials used in the construction and building fields --- in the Tri-city area of Rock Island and Moline, Ill., & Davenport, Iowa, and surrounding territory --- by graduate civil engineer with experience in architecture, engineering and construction. Write to Morris Garber, 2309 3rd Ave., Rock Island, Ill.

YOUNG GRADUATING ARCHITECT desires to make a connection with a firm involving airport terminal design. Background: Holding a valid Commercial Pilot License, graduate of Kansas State College, degree of B.S. Arch. Engineering and graduate Univ. of Michigan with degree B. of Architecture. Experience includes struct. design steel and concrete and supervision of construction. Address reply Box 234, ARCHITECTURAL RECORD, 119 W. 40th St., New York 18.

ARCHITECTURAL AND CIVIL ENGINEERS, 25-40 years with building construction knowledge, free to travel, head-quarter locations, Atlanta, Chicago, Cleveland, New York, Washington, to contact large architects and engineering offices to obtain acceptance of company products. Future excellent with *nationally known established manufacturer* of broad line of basic *building materials*. State age, ambitions, education, experience, salary expected, when available. Box 236, ARCHITECTURAL RECORD, 119 W. 40th St., New York 18.

Contemporary Shops in the United States

By EMRICH NICHOLSON

"Contemporary Shops in the United States" is a treasury of beautiful yet practical samples of store fronts and interiors, selected from among America's most progressive stores.

Including the supplement of 24 pages, over 400 illustrations, plans, etc., showing 113 shops, large and small, handling many lines of merchandise, located from coast to coast, designed by 70 leading designers and architects. 216 pages. 8½ by 11. \$10.00.

Book Department, ARCHITECTURAL RECORD
119 West 40th Street, New York 18, N. Y.

Please send one copy of CONTEMPORARY SHOPS IN THE UNITED STATES at \$10 per copy.

Money order or check for \$ enclosed
(For N. Y. City Delivery add 2% Sales Tax — \$10.20 in all)

Name

Address

City Zone State

A. R. 5 47

Tuf-flex doors are an important element of this Visual Front in Houston which displays the entire store to window shoppers.



NOW AVAILABLE!

**TUF-FLEX DOORS OF
L·O·F TEMPERED PLATE GLASS**

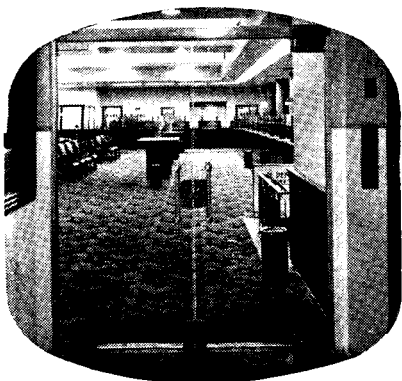

Attractive *Tuf-flex* doors make this bank in Toledo an inviting place in which to do business.

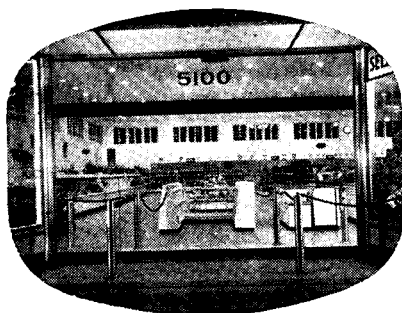

In this modern Montreal grocery *Tuf-flex* doors accentuate the openness of the Visual Front.

No need to dwell on the look of smartness and openness that *Tuf-flex** doors give a storefront, building entrance or interior. They are a key element in modern design . . . particularly in the Visual Front.

The big news is that *Tuf-flex* doors again are available. Your L·O·F Distributor now carries them in stock, in sizes determined to fit most architectural needs. When you make your plans, get in touch with him regarding available and desired sizes which will enable you to meet your construction schedule.

Plan to add the distinctiveness of these doors to buildings you design—whether new construction or remodeling. And write us for our new *Tuf-flex* door books, which illustrate many uses and give information on hardware fittings and other data. Libbey-Owens-Ford Glass Company, 6557 Nicholas Building, Toledo 3, Ohio.

*Reg. U.S. Pat. Off.



LIBBEY·OWENS·FORD
a Great Name in **GLASS**

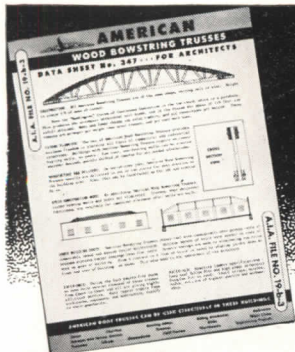

**SEND FOR
ARCHITECTS
ROOF TRUSS
DATA SHEET**

Free!

**AMERICAN BOWSTRING WOOD TRUSSES
BETTER . . . AND READY FOR
IMMEDIATE DELIVERY**

Here are several of the many reasons why experienced Architects and Engineers prefer American Bowstring Wood Trusses:

- Lower original cost
- Lower Fire Insurance rates
- Lower percentage of expansion
- Lower thermal conductivity
- No Maintenance
- Available Now!

For Commercial, Industrial, Recreational Buildings.
Spans to 150 feet.

25th Anniversary 1922-1947



AMERICAN ROOF TRUSS CO.

CHICAGO, 49 • 6844 Stony Island Avenue • Phone PLaza 1772
LOS ANGELES, 37 • 292 W. Santa Barbara Ave. • Phone ADams 1-4379

REMOVAL NOTICE

NATHAN STRAUS-DUPARQUET, INC.

Has Moved to

33 East 17th Street

UNION SQUARE NORTH

New York 3, N. Y.

Telephone: ALgonquin 4-3600

● Our new establishment is the result of more than two years of careful planning to create a large, modern organization . . . devoted to serving completely and efficiently . . . Hotels, Restaurants, Clubs, Hospitals, Ships, Schools and Institutions . . . our policy for over a century!

In designing your restaurant may we remind you that the Nathan Straus-Duparquet, Inc. Food Service Engineers are at your service — to assist you in your kitchen and cafeteria problems.

OVER A CENTURY'S EXPERIENCE IN SERVING THE INSTITUTIONAL FIELD!

BOSTON • MIAMI • CHICAGO • NEW HAVEN

**BEFORE THE INK
STARTS TO RUN**

HORN FOLDING BLEACHERS

HORN FOLDING PARTITIONS

SEE LISTING IN
SWEET'S
OFFICES IN
PRINCIPAL CITIES

Horn **BROTHERS**
Company
FORT DODGE, IOWA

**WHICH
COLOR?**

Here's
the Answer!



A "find" for the ARCHITECT!

When your clients ask "What color will be best?" you'll have a quick answer in the handsome Moleta COLOR GUIDE.

150 beautiful colors are displayed . . . Blues, Greens, Yellows, Grays, Browns . . . every tint from the palest to the darkest!

Formulas are given on the reverse of each color sheet (9" x 15") to show how the shade can be quickly made. Price, \$5.00 . . . delivered anywhere in the U.S.A. Write for your copy.

MONROE, LEDERER & TAUSSIG, INC.
606 N. AMERICAN STREET PHILA. 23, PA.

Moleta
ARCHITECTURAL

**FLAT
OIL PAINT**

THE TRULY WASHABLE FLAT PAINT

HIGH EFFICIENCY

IN

HEAT TRANSFER...

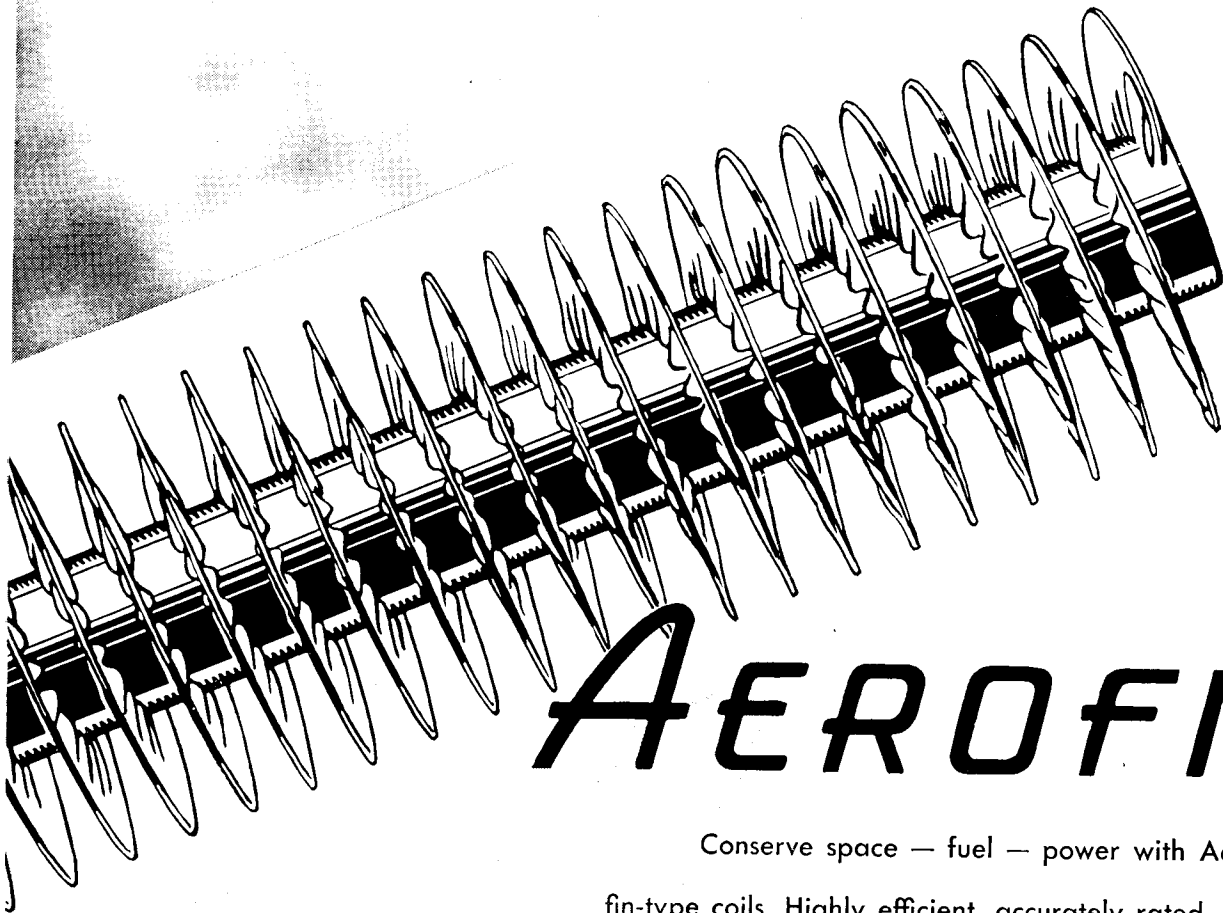

AEROFIN

*Aerofin is sold
only by manufacturers
of nationally advertised
fan system apparatus.
List on request.*

Conserve space — fuel — power with Aerofin fin-type coils. Highly efficient, accurately rated — Aerofin maintains its rated efficiency throughout the life of the installation. These carefully engineered coils are available in a complete range of sizes and types for any heat-transfer application.

Aerofin engineering service is available upon request.

AEROFIN CORPORATION

410 South Geddes St., Syracuse 4, N. Y.

NEW YORK • CHICAGO • CLEVELAND • DETROIT • PHILADELPHIA • DALLAS • MONTREAL

Send for new Catalog No. 46

You'll find it a big aid in planning Over-ALL Lighting for school, office, store and drafting room.

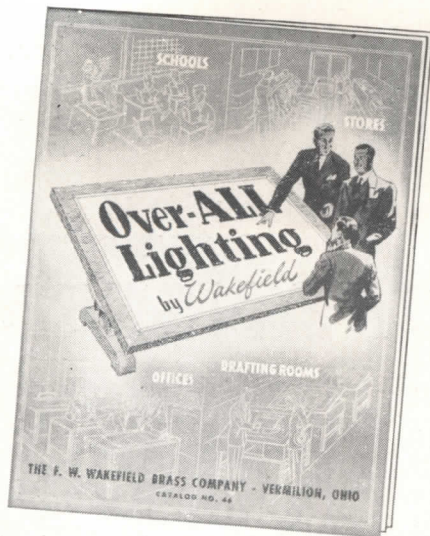

• This new catalog suggests a completely different way to look at lighting, in terms of overall results; gives the facts you need to apply it. You'll find the data helpful, practical, complete in details. Tells you how Wakefield's new Over-ALL Lighting can serve your clients; gives "blue-print" facts on the varied Wakefield lighting units you can use to provide it. Send for your copy today. The F. W. Wakefield Brass Company, Vermilion, Ohio.

Wakefield

Lighting Equipment for Office, School and Store



The General

Beacon

Grenadier

Commodore

Its new... the STAR

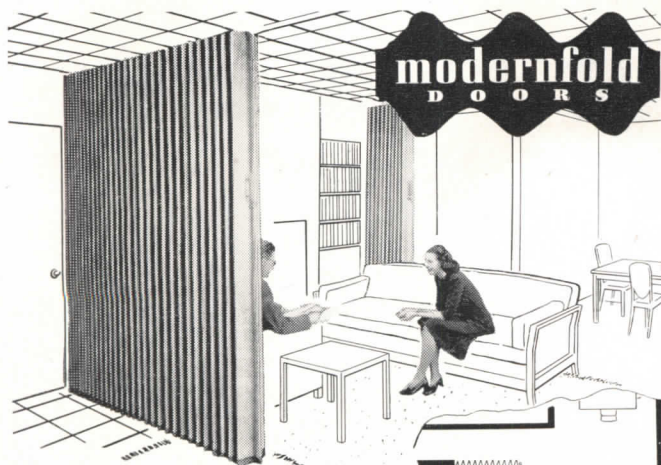

Tailor your rooms to fit your needs!

• Beautiful Modernfold Doors make space flexible! For instance, a large room can do double-duty . . . by dividing it into two or more smaller rooms with this amazing accordion-type door. With the doors closed, Modernfold assures small room privacy. But if the entire area is required, merely fold the doors to the wall. Specify these fabric-covered, metal-framed closures . . . for living rooms, dining rooms, bedrooms, kitchens, closets. They are available in approximately 30 to 45 days after receipt of order at factory. Write for full details.

Dealers in all principal cities in the United States and many foreign countries

NEW CASTLE PRODUCTS • NEW CASTLE, INDIANA

STOP that WATER with FORMULA #640

A Clear Liquid Waterproofing for Old or New Construction

PENETRATES deeply—one inch or more—is not a surface treatment. Brush, spray, or float on stone, cast stone, concrete, mortar, stucco, tile, brick, plaster, wood, wall board — any absorbent material.

WATERPROOFS, preserves, prevents dusting of floors, surface dirt washes away in rain.

FORMULA No. 640 is a balanced formula of seven different waxes and resins in a hydrocarbon solvent.

ACID-ALKALI proof — does not oxidize, unchanged by temperature.

PERFORMANCE — It is our opinion it will last as long as the concrete, mortar, stucco, etc., lasts.

OIL PAINT saponifies on cement unless sealed first with Formula No. 640.

APPLY to either side: **The pressure side, or opposite side** — it is equally effective.

HYDROSTATIC PRESSURE — A 20 foot head has been held by Formula No. 640.

CUTS WATERPROOFING COSTS

because it applies three times as fast as paint, requires no special technique. No preparation — comes ready to apply. Eliminates necessity of furring. Concrete floors and walls need no membraning.

KEEPS IN ALL CLIMATES • **HARMLESS TO USE**
GOOD COVERAGE • **MODERATE PRICE**

WRITE OUR ENGINEERING DEPARTMENT for office test kit, technical data, or regarding any special problem.
J. Wilbur Haynes, Engineer

OTHER PRODUCTS: Formula No. 640 Toxic, combines waterproofing with termite and fungus protection; cement hardener; cement paint; floor mastic; roof coatings, etc.

HAYNES PRODUCTS CO.

4007 FARNAM STREET • OMAHA 3, NEBRASKA



For less than one thousand dollars . . . your church may have today's finest carillon.

Maas, dual-purpose* Cathedral Chimes, beginning at nine-hundred fifty dollars, have earned a significant reputation among music directors and organists throughout the country. Perfect tuning, clear, responsive action, beautifully pure tonal qualities are characteristic features of every Maas chime system, with a wide range of models to meet varying needs differing only in sound coverage and number of notes. Prices of more extensive systems are correspondingly reasonable.

* The Maas dual-purpose system combines both inside cathedral chimes and outside tower carillon. The same chimes with inside facilities only, start at \$518.00.

M A A S
Carillons

SEND FOR DESCRIPTIVE LITERATURE; SPECIFY TYPE OF ORGAN YOU HAVE.

M A A S ORGAN COMPANY
ROOM 21, 3015 CASITAS AVE
LOS ANGELES 26, CALIFORNIA



THESE ARE THE TOOLS OF ENGINEERED AIR CONDITIONING

The best air conditioning is that which completely fits the needs of the people using it. Since people differ—as do their homes, offices, and plants—the best air conditioning cannot come out of a standardized package, but must be *engineered* to meet the exacting requirements of each single application.

An air conditioning system by Trane means equipment that is produced by an organization of manufacturing engineers—equipment that is designed, developed, and built to the highest engineering standards, and that may fully incorporate all phases of complete modern air conditioning in any combination.

Because Trane manufactures a *complete* line of heating and air conditioning products, architects, engineers and contractors can plan entire Trane systems, obtaining all the necessary elements from one source, with one responsibility. Trane field offices in 85 principal cities offer these men their entire co-operation.

* * *

The Convactor-radiator—modern successor to the old-fashioned cast iron radiator—has been engineered by Trane for universal application to steam and hot water heating systems, and is being produced in quantity so you can soon secure it from local distributors' stocks.

TRANE

Manufacturing Engineers of Equipment for
HEATING AND AIR CONDITIONING

THE TRANE COMPANY, LA CROSSE, WISCONSIN • Also TRANE COMPANY OF CANADA, LTD., TORONTO, ONTARIO



NOW READY FOR SHIPMENT
Specify **LUCKE** Leak Proof Bathtub Hangers

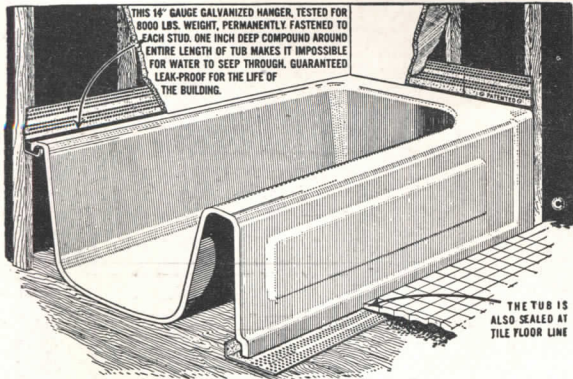

IF IT IS A LUCKE PATENTED TUB HANGER—IT IS LEAK-PROOF

In New Construction or Remodeling—Remember The Modern Way To Prevent Leaks

There is no excuse for cracks, leaks or repair expense in good building—that is why LUCKE was designed. Leading architects, contractors and plumbers today use LUCKE to prevent expense, or spoiled ceilings, and to guarantee tub edges from leaks.

Install LUCKE For Permanence

This feature is well worth emphasizing because you can then assure owners they will never have to spend money for repairs. Reasonably priced life-time protection.

Sold By Leading Plumbing Supply Houses

Manufactured By

WILLIAM B. LUCKE, INC.
WILMETTE, ILLINOIS

Boston Minneapolis Los Angeles
New York New Orleans Seattle



**DELANY
FLUSH VALVES**

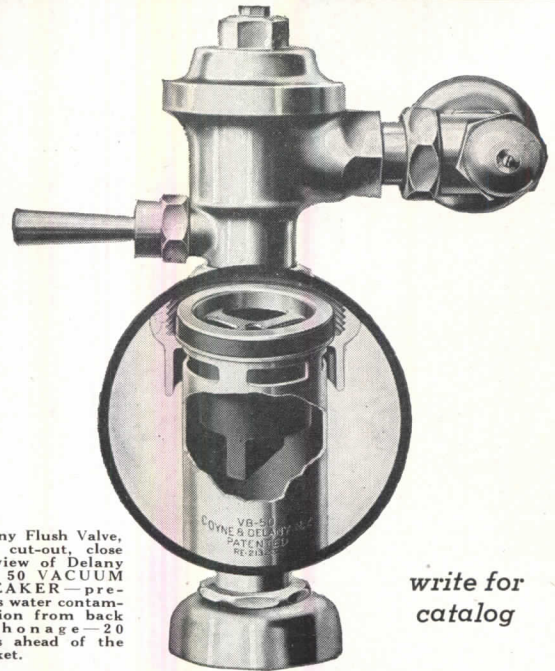

Delany Flush Valve, with cut-out, close up view of Delany No. 50 VACUUM BREAKER—prevents water contamination from back siphonage—20 years ahead of the market.

write for catalog

SINCE 1879
Coyne & Delany Co.
BROOKLYN N.Y.

Protect Your Construction from Mold, Decay, Termites Warping and Shrinking

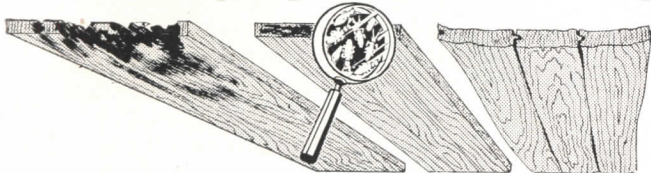

Guards against decay, mold, termites—even warping and shrinking! Clean oil preservative and water repellant. Treated wood is odorless and paintable.



For decay resistance and termite prevention. There is a Timbertox for every purpose. 9 standard Pentachlorophenol oil preservatives.



For dimensional control of interior woodwork—millwork, paneling, trim, etc. Resists warping, swelling, shrinking, checking and grain raising. Improves paintability.

Write for new bulletin: Protection of Wood by Chemical Treatment

WOOD TREATING
Chemicals Co.
5137 Southwest Ave.
St. Louis 10, Mo.

THERE IS A FEDDERS UNIT HEATER MAN



AS NEAR AS YOUR PHONE

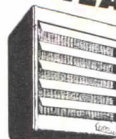

The classified section of telephone directories of principal cities lists the name of the Fedders representative under the heading HEATERS - UNIT.

FEDDERS-QUIGAN
CORPORATION
BUFFALO 7 • NEW YORK

Another new sash

IN PITTCO DE LUXE STORE FRONT METAL

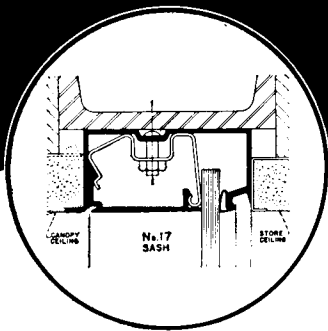
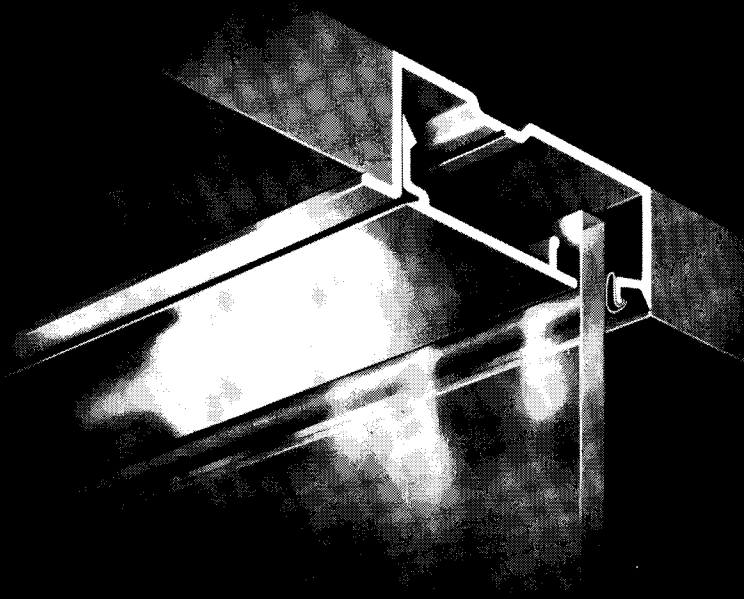

Newest member of the Pittco De Luxe line of store front metal is this flush type sash (No. 17). It was designed primarily for use where the architect wishes to have the ceilings of canopy and store on the same plane, apparently joining each other without interruption. It can also be used at the sides. Of special importance is the fact that this new sash is self-adjusting to allow for a certain amount of deflection in beam or canopy . . . *there are no obstructions between the edge of the glass and the inner member.* The extruded construction of sash No. 17 assures sturdy strength and a rich, smooth finish, and it can be used in combination with all other Pittco members, whether De Luxe or Premier.

The creative thinking that went into the design of this new sash is only one example of the careful planning that has won so many friends for both lines of Pittco Store Front Metal. Sturdy construction, distinctive styling, ease of installation, and a rich finish have made Pittco De Luxe an outstanding leader for high quality store front installations. Pittco Premier satisfies every requirement for a lighter weight, more moderately priced metal which can be set easily and quickly.

PITTCO

STORE FRONT METAL



"PITTSBURGH" stands for Quality Glass and Paint

PITTSBURGH PLATE GLASS COMPANY

For LOW COST INSURANCE



--against
the danger
of scalding water
In shower baths and
wash fountains

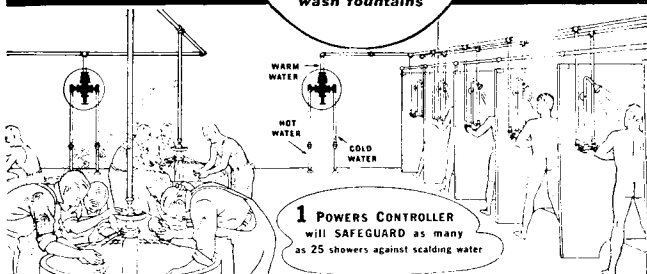

Use Powers Thermostatic Water Controllers for Group Showers, Wash Fountains, Hot Water Line Control and Industrial Processes. Capacities up to 2,650 g.p.m. Write for Circular 3017. THE POWERS REGULATOR COMPANY, 2752 Greenview Ave., CHICAGO—Offices in 47 Cities 52A

POWERS WATER TEMPERATURE CONTROL

The Burt line includes gravity, fan and continuous ridge types

BURT
Free-Flow Fan
VENTILATORS

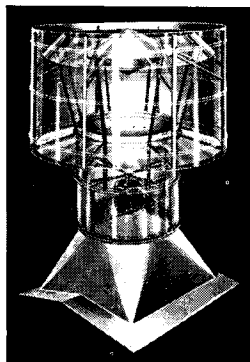

FOR FAST, CONTROLLED VENTILATING EFFICIENCY

The Burt Free-Flow Fan Ventilator offers you several important advantages. When its fan is not in use, it acts as a gravity unit. With its fan in operation, capacity is greatly increased, regardless of access to wind flow. It can be spotted directly over area to be ventilated or used on duct work flues to increase their capacities. See Sweet's or write for data sheets on this highly efficient unit.

THE BURT MFG. CO.
ROOF VENTILATORS • OIL FILTERS
EXHAUST HEADS
48 East South St., Akron 11, Ohio

SEND FOR CATALOGS
Burt Engineers are glad to help on plans



*Beautiful!
Preserve!
Protect!*

That
**OUTSIDE
LOOK**

CREO-DIPT STAINS
FOR WOOD SHINGLE ROOFS AND SIDE WALLS

CREO-DIPT
COMPANY, INC.
Established 1911
NORTH TONAWANDA, N. Y.

... the stopping place of busy people!

In the Heart of Pittsburgh's Golden Triangle . . . within easy walking distance of all important office buildings, stores and theatres . . . the Pittsburgher is the ideal spot to stay

You'll enjoy the large comfortable rooms, every one with a private bath and radio . . . the excellent restaurants . . . and the friendly courtesy that always awaits you at the Pittsburgher

Single Rooms: \$3.50 to \$5.00
Double Rooms: \$5.00 to \$7.00

A KNOTT HOTEL—Joseph F. Duddy, Manager



HERRING-HALL-MARVIN ENGINEERS

present to the nation's bankers

**THE SAFEST • MOST CONVENIENT • MOST DEPENDABLE
BURGLAR-RESISTIVE NIGHT DEPOSITORIES
THAT THE ART AND SCIENCE OF METALCRAFT
ENGINEERING HAS EVER PRODUCED**

3 GREAT SYSTEMS TO CHOOSE FROM

1—The ROTARY. 2—The CIRCULAR. 3—The SIMPLEX. Each in its class represents the highest modern achievement in structural integrity combined with architectural adaptability and guaranteed burglar-resistive protection.

INSURANCE PROTECTION

Herring-Hall-Marvin Night Depositories are designed, built and installed to rate the highest Night Depository Insurance Classification money can buy—Underwriters' Certified Bank Burglary Class "B". We make no compromise with safety.

ENGINEERING COOPERATION

Herring-Hall-Marvin places at your disposal the cooperation of a qualified Night Depository engineer—to assure you every possible advantage of convenience and protection. This cooperation is available on new construction or replacement, as required.

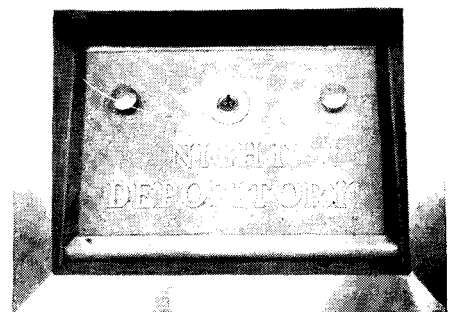

H-H-M ROTARY NIGHT DEPOSITORY H-H-M CIRCULAR NIGHT DEPOSITORY H-H-M "SIMPLEX" NIGHT DEPOSITORY

WHY EXPOSE YOUR BANK TO COSTLY PENALTIES?

The bank burglar is definitely with us again. There were more than twice the number of successful bank burglaries in '46 as there were in '45. The attitude that it can't happen here has cost many banks 5-year insurance penalties of 66-2/3% — amounting to thousands of dollars! Why risk such embarrassment? Why hazard such loss of customer good will? Or such needless dissipation of a good bank's assets? Your H-H-M Night Depository will both protect your bank and assure your stockholders appreciated peace-of-mind. Wire, write or telephone for descriptive literature and prices—today!

HERRING-HALL-MARVIN SAFE CO. *General Offices*
HAMILTON, OHIO



Double

FOR THE MONEY

See pages 8-9

THE STAIN WITH SOMETHING extra



Cabot's unique *collopping* process reduces pure color pigments to particles 100 to 1000 times smaller than those in ordinary paints and stains—combines them with specially processed oil. For this reason, Cabot's Stains penetrate far into the wood, giving it a deep, rich, permanent color, and displaying grain texture to best advantage.

Cabot's Stains are made with a high proportion of undiluted creosote oil, the best wood preservative known. They cost $\frac{1}{3}$ as much as good paint... are quick and easy to apply.

Write today for free sample and complete information. Samuel Cabot, Inc., 1292 Oliver Bldg., Boston 9, Mass.

CABOT'S CREOSOTE STAINS

FITZGIBBONS

The right steel boiler in any size



Make it a Fitzgibbons and be sure, whether to heat a modest cottage or a towering sky-scraper. Be sure of full heating comfort, of vital savings in fuel cost, of a boiler that works in harmony with any good oil burner, gas burner, stoker, or gives full hand-fired satisfaction. Be sure, with a boiler that is A.S.M.E. constructed, Hartford inspected, S.B.I. rated, and with sixty continuous years of successful boiler building behind it. Check with your local Fitzgibbons engineer—or write us direct.

- 400 SERIES for modest homes
- OIL-EIGHTY for medium size homes
- R-Z-U JUNIOR for large residences and apartment buildings
- D-TYPE for institutional and office buildings, hospitals, theatres, etc.

MEMBER SBI

REG. U. S. PAT. OFF.

Most Economical in Fuel

Fitzgibbons Boiler Company, Inc. 101 PARK AVE. NEW YORK 17, N. Y.

The New HAWS Electric Water Coolers



are distinctively designed to enhance the interior beauty of tomorrow's buildings. For office, lobby, store or public building HAWS Electric Water Coolers serve, with complete sanitation, refreshing drinking water; serving efficiently, dependably and economically. For the finest in electric water coolers, specify, insist, install HAWS Electric Water Coolers NOW!

Agents and Sales Representatives in all Principal Cities

HAWS

DRINKING FAUCET CO.

(Since 1909)

1808 HARMON STREET
BERKELEY 3, CALIFORNIA

The PLANNING BOARD



The Truscon Planning Board Says: "With the high degree of production efficiency which has now been attained in the

Truscon plants, we are able to meet normal demands for delivery of many of our steel building products." Contact the nearest Truscon District Sales Office for up-to-the-minute information, and cooperation in filling your requirements with the greatest efficiency.

608 New Apartments

There'll soon be a lot of pleased and happy new residents in the area between 9th and 10th Avenues, and West 25th and West 27th Streets, in New York City. This is the site of the Elliot Housing Project, consisting of four big modern structures containing 608 modern apartments, and rapidly being readied for habitation.



Truscon Diamond Metal Lath Used in Elliot Housing Project, New York City.

Large quantities of Truscon Diamond Metal Lath, in conjunction with Truscon 3/4" Channels and Tie Wire, were used for the 2" solid metal lath and plaster partitions for this project. These Truscon steel building materials served several important functions: (1) They permitted the quick, low-cost coverage of large areas with smooth, flat lath; (2) they met strict fire-proofing requirements; and (3) they helped attain a high quality of plastered job, and will protect the fine appearance of the walls and ceilings for a great many years.

Truscon Diamond Lath is a flat metal lath, uniformly expanded throughout the entire

sheet. Its use is almost universal, for it is adaptable for practically all classes of work—as a base for walls, partitions, ceilings, as a reinforcement for stucco, as a protection for steel beams and columns, and for protecting hazardous points in wood frame construction—such as ceilings under inhabited floors, especially over heating plants and coal bins, around flues, and back of kitchen ranges, stair wells, and under stairs.



Truscon Cold Rolled Channels are straight and true, with square corners that prevent rolling.

Illustrating the straight, true plastered walls secured with Truscon Metal Lath Products.

More "Light-Power" for Power Houses

There is a growing use of Truscon Donovan Steel Windows for structures housing power units. These windows permit modern, streamlined design for exterior distinctiveness in appearance. Large areas can be covered by one complete window unit, permitting ample introduction of light and air.

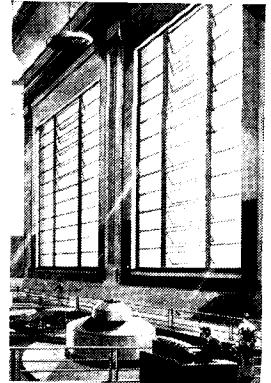

The operator mechanism, although concealed, assures positive control of the window openings. This mechanism replaces the unsightly mechanical operators usually necessary to effectively control ventilators. The steel sections used in Donovan Windows are rolled exclusively for Truscon, and are the largest and heaviest steel sections manufactured expressly for windows. Write for free catalog describing Truscon Donovan Steel Windows.

A Steel Window for Every Purpose

Did you know that Truscon Steel Company fabricates a more diversified line of steel windows than any other window manufacturer? Truscon also manufactures practically all of the necessary collateral window equipment such as mechanical operators and screens. There is a type of window design to meet any window requirement in any type of building in any industry. Ask for information on Truscon's complete line of steel windows.

Sky High

Truscon design and engineering ability in steel construction is evidenced by Truscon contracts to build America's tallest radio towers. The tallest one right now, is the WKY Radio Tower in Oklahoma City, 956 feet high from the ground to the top of the FM antenna. Tall or small, AM to FM, Truscon can supply guyed or self-supporting radio towers for every requirement.



New Literature

Write for catalog describing the new Truscon line of plastering accessories, including Bull Nose and Scalloped Edge Corner Beads, Special Base Grounds and Screeds, Picture Mold, Casings, Fittings and other items.



TRUSCON
STEEL COMPANY
 YOUNGSTOWN 1, OHIO
 Subsidiary of Republic Steel Corporation

New Idea...

SIMPLIFIES CONSTRUCTION

SAVES SPACE

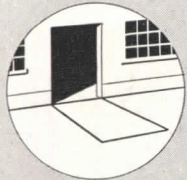

Levelator lowered becomes part of floor and can be trucked over. When loaded, Levelator rises smoothly to required level.

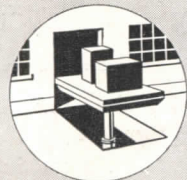

Cross loading docks and ramps off your plans by specifying Rotary Levelators. Floors can be poured on grade instead of at railway car or truck bed height. You save space and give clients more efficient buildings at lower cost. Levelators lift loads quickly to trucks, freight cars or different building levels. Operated by Oil-draulic power. Installation simple. Write for Catalog RE-201.

ROTARY LIFT CO.
1007 Kentucky
Memphis 2, Tenn.



Rotary
LEVELATORS

Fabron for WALLS
REG. U. S. PAT. OFF.

THE CANVAS-PLASTIC-LACQUER FINISH

Where Appearance
Performance
Economy
Are Important

- it decorates the wall permanently
- it withstands hard usage
- it reinforces sub-surface materials
- it prevents plaster cracks
- it is washable and sunfast

These features commend it for interiors of any type building.

FREDERIC BLANK & COMPANY, INC.
230 PARK AVENUE - NEW YORK 17, N. Y.

Available Now!

CHENEY
FLASHING

3-Way Bond

16 OZ. COPPER

CHENEY
FLASHING
REGLET

16 OZ. COPPER

WRITE FOR
DESCRIPTIVE FOLDER Dept. R

CHENEY INDUSTRIES, Trenton, N. J.

CHENEY FLASHING is again being made by the original inventor who pioneered the art of thru-wall flashing eighteen years ago.

No thru-wall flashing can operate successfully unless it has the two very important features that are found in CHENEY FLASHING—proven weep-hole drainage and the three-way bond, vertical as well as longitudinal and lateral.

Remember, the inferior two-way flashings, crimped copper and membranes, have neither the vertical bond nor do they drain moisture from the wall fast enough. Furthermore, their first cost advantage has disappeared because today Cheney Flashing is no longer a specialty—it's a standard commodity.

Lockwood

**IDENTIFIES QUALITY
IN BUILDERS' HARDWARE**

LOCKWOOD identifies its Builders' Hardware with this famous Trade Mark. You will find it on cylinder locks and keys, on mortise locks, on door closers . . . a symbol of enduring quality since 1882.

To the Architect the name LOCKWOOD also signifies a line of Builders' Hardware embracing all requirements, characterized by steady advancement in feature and design . . . and a company that never hesitates to give full and prompt co-operation.

We aim to keep it that way.

R-1

LOCKWOOD HARDWARE MFG. COMPANY

Division of Independent Lock Company

Fitchburg • Massachusetts

2nd Printing

The Complete . . . Authoritative up-to-the-minute Handbook

"Hospital Planning"

by CHARLES BUTLER, F.A.I.A., and ADDISON ERDMAN, A.I.A.

A Case-Study Analysis of Modern Hospitals

With tremendous energy and insight Charles Butler and Addison Erdman, distinguished architects and hospital consultants, have made a nation-wide survey of the current adaptation of hospital architecture to changing practices in hospitalization.

The fruits of their study are set forth in "Hospital Planning" — a completely new treatise of present-day practices, based on a painstaking study of hundreds of institutions from which have been selected fifty-one modern hospitals, representing the creative efforts of more than thirty architectural firms, for illustration and discussion. "Hospital Planning" presents a textual summation of the outstanding problems in hospital architecture and shows how these problems have been met in actual practice. Generous use of illustrations, including perspectives, floor plans, elevations and photographs, make solutions abundantly clear and afford sound, applicable principles for innumerable problems to come.

**For Hospital Administrators . . . Superintendents
. . . Doctors . . . Architects**

This 232-page, fully-illustrated volume, carefully organized for both reading and reference, is designed for architects and hospital groups alike. It will help trustees, administrators and doctors to visualize their problems in terms of their community needs . . . show how others are meeting similar problems . . . provide them with a basic understanding of hospital architecture so that they may intelligently discuss their problems with the architect.

It will help architects and engineers to learn of the great advances made in hospital architecture . . . to acquire a working knowledge of medical problems and hospital procedure . . . to avoid the many pitfalls which beset the hospital planner.

Order Your Copy Now

With this second printing "Hospital Planning" is again temporarily available at the price of \$15. It is offered with the full knowledge that it may be worth incomparably more to you than its cost — so much more that cost is no valid consideration.

So use the convenient coupon below to make sure to get your copy of "Hospital Planning" before the second printing is sold out. The book will be sent promptly, prepaid.

A FEW of the architectural firms whose works were selected for discussion and illustration include . . .

- Coolidge, Shepley, Bulfinch and Abbott
- Samuel Hannaford & Sons
- Schmidt, Garden and Erickson
- Jamieson and Spear
- Charles B. Meyers
- James Gamble Rogers
- Mayers, Murray and Phillip
- Eggers and Higgins
- Crow, Lewis and Wick

Mail this coupon today

ARCHITECTURAL RECORD BOOK DEPARTMENT
119 West 40th Street, New York 18, New York

Enter my order for . . . copy(s) of the new printing of "Hospital Planning" by Charles Butler and Addison Erdman at the price of \$15 a copy. I enclose payment of \$
(For New York City delivery, add 30 cents for Sales Tax — \$15.30 in all.)

Name

Address

City Zone State



232 pages . . .
size 8 1/2 x 11 inches . . .
17 chapters . . .
profusely illustrated . . .
thoroughly indexed . . .
detailed table of contents . . .
stiff cloth binding . . .
Price \$15

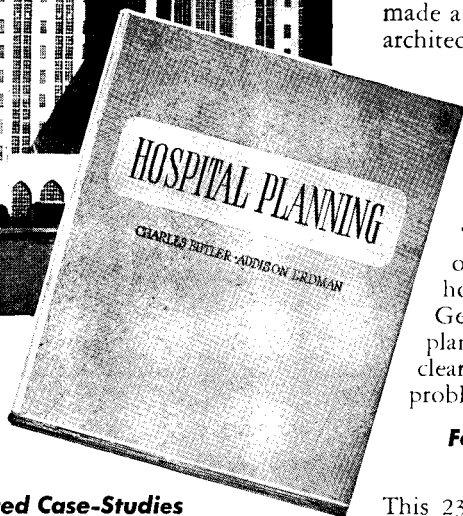

Hundreds of Illustrated Case-Studies

"Hospital Planning" presents the plans of fifty-one selected modern hospitals . . . represents the creative efforts of 30 architects. Includes 32 photographs . . . 11 site plans . . . 187 floor plans . . . 38 special unit plans of rooms, wards and departments . . . numerous construction details.

THE AUTHORS—Perhaps no other two authors are so well qualified by background and experience to write a volume of such broad scope and magnitude as those selected for this authoritative and technically difficult work.



Charles Butler has been closely associated with hospital planning throughout his broad professional career. As architect or consultant, his works include St. Luke's International Medical Center, Tokyo; War Demonstration Hospital at Rockefeller Institute; Goldwater Memorial Hospital.



Addison Erdman, holder of the A.I.A.'s Langley Fellowship for two successive years, is a consultant on hospitals for a number of architectural firms. His works include the Mobile Hospital Unit for the British Army in Egypt, the Private Patient Pavilion, Methodist Hospital of Brooklyn. Recently appointed as one of the five architects consultants for the Veterans Administration.

HOSPITALS selected for illustration include — Cornell-New York Medical Center, New York; Goldwater Memorial Hospital, Welfare Island, New York; Methodist Hospital, Brooklyn; General Hospital, Cincinnati; Saint Vincent's Hospital, New York; Community Hospital, Battle Creek; Saint Mary's Hospital, Rochester, Minnesota; American Memorial Hospital, Reims, France; Mallinckrodt Institute of Radiology, Saint Louis; Royal Victoria Hospital, Montreal; Rochester Municipal Hospital, Rochester, New York; Potts Memorial Hospital, Livingston, New York; Fort Sill Hospital, Fort Sill, Oklahoma. Saint Luke's Hospital, Spokane, Washington; Massachusetts General Hospital, Boston and many more.



LONE STAR CEMENTS

COVER EVERY CONSTRUCTION NEED

LONE STAR PORTLAND CEMENT

for concrete of outstanding quality in all types of construction

'INCOR' 24-HOUR CEMENT

America's FIRST high early strength Portland Cement—saves time, cuts costs

LONE STAR MASONRY CEMENT

The modern masonry cement, for really great job performance

*Reg. U. S. Pat. Off.

LONE STAR CEMENT CORPORATION

Offices: Albany • Birmingham • Boston • Chicago • Dallas • Houston
 Indianapolis • Jackson, Miss. • Kansas City, Mo. • New Orleans • New York
 Norfolk • Philadelphia • St. Louis • Washington, D. C.



U. S. MAIL CHUTES

Cutler Mail Chutes are made in a factory expressly designed and constructed for one product . . . The Cutler Mailing System.

Catalog in Sweet's

ESTABLISHED 1883

Cutler Mail Chute Co

ROCHESTER 7, N. Y.

NORTON DOOR CLOSERS

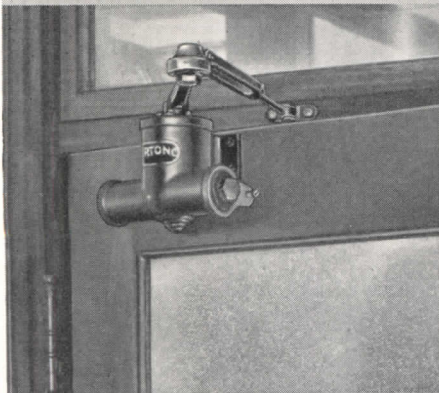

Built Up to an Exact Standard Not Down to a Cut Price

Geared to do the Job!

NORTON DOOR CLOSER COMPANY

Division of The Yale & Towne Mfg. Co.
 2900 N. Western Ave., Chicago 18, Ill.



Steel Precision Rack and Pinion



The Lord Baltimore Hotel, Baltimore's largest, always has upheld this tradition. 700 comfortable rooms . . . all the facilities and services that travelers expect . . . and a genuine willingness to please each guest . . . have made it "Host to Most Who Visit Baltimore."

THE Lord Baltimore Hotel

BALTIMORE AT HANOVER • BALTIMORE 3, MD.

Plan for health-safety ... it comes first

Whether it's a hospital, church, school or public building, architects know that the specification of Halsey Taylor Drinking Fountains is an assurance that health-safety comes FIRST! For these modern fountains were developed primarily to protect the user from contamination. Sanitation is as important as design... Halsey Taylors provide both! Get our latest literature.

THE HALSEY W. TAYLOR CO.
WARREN, OHIO



Halsey-Taylor
DRINKING FOUNTAINS

A-3



The Colored Spots are
our Trade Mark. Reg.
U.S. Pat. Off.

SPOT SASH CORD

WITH WEIGHTS AND PULLEYS

— the one method of hanging windows that has been proved by generations of actual use to provide perfect and permanent balance.

SAMSON CORDAGE WORKS · BOSTON 10, MASS.

the **LUMINALL** line
of interior flat wall paints



LUMINALL... has casein binder for extra light reflection

ULTRA LUMINALL... has synthetic resin binder for extra washability

FREE... Send for fully illustrated 24-page book, "Painting for Light & Decoration."



NATIONAL
3627 South

Factories:

CHEMICAL & MFG. CO.
May Street, Dept. G, Chicago 9, Illinois

Chicago, Ill., Brooklyn, N. Y.
Distributors in all principal cities

FIRST INTRODUCED IN JUNE, '45
THIS

*New Development
in Radiant Heating*

HAS CREATED TREMENDOUS
PUBLIC INTEREST

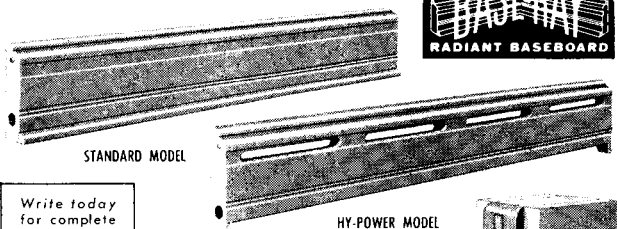

Write today for complete information. You may be asked about BASE-RAY tomorrow.
*Reg. U.S. Pat. Off.

Burnham Corporation
BOILERS and RADIATORS

IRVINGTON, N. Y.



MAKERS OF THE FAMOUS
YELLO-JACKET BOILER

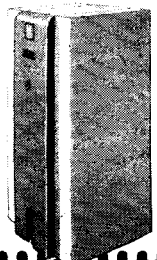

INDEX TO ADVERTISEMENTS

Catalogs of Concerns marked (s)
are filed in Sweet's File (1947

s Adam, Frank, Electric Company.....	57	s Great Lakes Steel Corporation.....	29	Norge Division.....	159
Aerofin Corporation.....	221	Guth, Edwin F., Company.....	49-52	s Norton Door Closer Company.....	232
Air Reduction.....	22	s Hart & Hegeman Division.....	214	Ohio Chemical & Mfg. Company.....	193
s Airtemp Division.....	47	s Haws Drinking Faucet Co.....	228	Okonite Company.....	190
s Aluminum Company of America.....	181	Haynes Products Company.....	222	s Otis Elevator Company.....	70
s American Air Filter Co., Inc.....	198	Hazard Insulated Wire Works Division.....	190	s Owens-Illinois Glass Company.....	68-69
s American Blower Corporation.....	54	s Herring-Hall-Marvin Safe Co.....	227	s Oxalid Products Division.....	1
s American Brass Company.....	77	Homasote Company, Inc.....	216	s Petroleum Heat & Power Company.....	66
s American Flange & Manufacturing Co., Inc.....	36	s Hood Rubber Co.....	46	s Pittsburgh Corning Corporation.....	31-177
American Gas Association.....	34-35	s Hook & Ackerman, Inc.....	208	s Pittsburgh Plate Glass Company.....	225
American Roof Truss Company.....	220	s Horn, A. C., Company, Inc.....	173	Ponderosa Pine Woodwork.....	15
s American Steel & Wire Company.....	21	s Horn Brothers Company.....	220	s Powers Regulator Company.....	226
s Anaconda Copper Mining Co.....	77	Hotel Pittsburgher.....	226	Propellair Division.....	12
s Anchor Post Products, Inc.....	176	Imperial Brass Mfg. Co.....	6	s Republic Steel Corporation.....	18-229
s Anemostat Corporation of America.....	83	s Independent Lock Co.....	230	s Revere Copper & Brass, Inc.....	80
Arabol Manufacturing Co.....	46	s Indiana Limestone Institute.....	192	s Reynolds Metals Company.....	59
Architectural Record.....	204	s Ingersoll Steel Division.....	38-39-67	Richmond Radiator Company.....	75
s Arketex Ceramic Corporation.....	179	s Insulite Co. Division.....	8-9-206-228	s Ric-Wil Company.....	171
s Armstrong Cork Company.....	32-33	International Nickel Company, Inc.....	217	Rittling Corp.....	176
s Arrow-Hart & Hegeman Electric Co.....	214	s Irvington Form & Tank Corporation.....	25	Robbins & Myers, Inc.....	12
s Barber-Colman Company.....	170	Jenkins Bros.....	81	s Roddis Lumber & Veneer Co.....	40
Benjamin Electric Mfg. Co.....	41	s Johns-Manville.....	186-187	s Rotary Lift Co.....	230
s Bethlehem Steel Company.....	203	s Josam Manufacturing Co.....	17	s Ruberoid Co.....	55
Bigelow-Sanford Carpet Co., Inc.....	64	s Keasbey & Mattison Company.....	161	Salter, H. B., Mfg. Co.....	16
s Bird & Son, Inc.....	174	s Kewanee Boiler Corporation.....	58	s Samson Cordage Works.....	233
Bituminous Coal Institute.....	56	Kiesling, John W. & Son, Inc.....	195	Schlage Lock Company.....	172
s Blank, Frederic, & Co., Inc.....	230	s Kimberly-Clark Corp.....	189	s Seaport Porcelain Metals, Inc.....	210
Blodgett, G. S., Co., Inc.....	162	Kinetic Chemicals Inc.....	78	Servel, Inc.....	72-73
s Blue Ridge Sales Division.....	20	s Kinnear Manufacturing Co.....	156	s Serviced Products Corp.....	174
Books.....	178-202-216-231	s Koppers Company Inc.....	45	s Sloan Valve Company.....	4th Cover
s Borg-Warner Corporation.....	38-39-67-159	s Leader Electric Company.....	19	s Smith, H. B., Co., Inc.....	152
Brasco Mfg. Co.....	213	s Libbey-Owens-Ford Glass Company.....	20-219	Smithcraft Lighting Division.....	201
Bright Light Reflector Company.....	14	s Lockwood Hardware Mfg. Co.....	230	s Soss Manufacturing Company.....	208
s Bull Dog Electric Products Company.....	13	Lone Star Cement Corporation.....	232	s Stanley Works.....	44
Burnham Boiler Corporation.....	233	Lord Baltimore Hotel.....	232	s Stran Steel Division.....	29
s Burt Mfg. Co.....	226	Lucke, Wm. B., Inc.....	224	Straus, Nathan-Duparquet, Inc.....	220
Byers, A. M., Co.....	4	Maas Organ Company.....	222	s Swartwout Company.....	212
s Cabot, Samuel, Inc.....	228	s Macomber, Incorporated.....	166	s Taylor, Halsey W., Co.....	233
Camfield Manufacturing Company.....	60	s Mahan, R. C., Company.....	23	s Thrush, H. A., & Company.....	194
s Carrier Corporation.....	182	s Marsh Wall Products, Inc.....	168	s Tile-Tex Company, Inc.....	211
Case, W. A., & Son Mfg. Co.....	3rd Cover	s Martin-Parry Corporation.....	65	Todd Shipyards Corporation.....	157
s Ceco Steel Products Corporation.....	2-3	Masland Duralcather Company.....	175	s Trane Company.....	223
s Celotex Corporation.....	149	s Mesker Brothers.....	76	s Truscon Steel Company.....	229
s Century Lighting, Inc.....	206	Michaels Art Bronze Company, Inc.....	158	Tuttle & Bailey.....	155
s Chase Brass & Copper Co.....	199	s Milcor Steel Company.....	236	Union Carbide & Carbon Corp.....	169
s Cheney Industries.....	220	Miller Company.....	11	United States Rubber Company.....	27
s Chrysler Corporation.....	47	s Minneapolis-Honeywell Regulator Co.....	84	s United States Steel Corporation Subsidiaries	21-191-215
Combustion Equipment Division.....	157	s Minnesota & Interior Paper Company.....	8-9-206-228	United Wall Paper.....	79
Connor, W. B., Engineering Corp.....	214	s Modine Manufacturing Co.....	167	s Universal Atlas Cement Company.....	215
s Coyne & Delany Company.....	224	Monroe, Lederer & Taussig, Inc.....	230	s Van Range, John Co.....	210
Crane Co.....	62	Morrison Steel Products, Inc.....	43	Varlar, Inc. Division.....	79
s Creo-Dipt Company, Inc.....	226	s National Association of Ornamental Metals	197	s Vonnegut Hardware Co.....	184
s Curtis Companies Service Bureau.....	71	Manufacturers.....	197	Wakefield, F. W., Brass Company.....	222
s Cutler Mail Chute Co.....	232	s National Chemical & Mfg. Co.....	233	s Webster, Warren Co.....	178
s Day-Brite Lighting, Inc.....	150	National Clay Pipe Manufacturers, Inc.....	82	s Weis, Henry Mfg. Co., Inc.....	164
s Detroit Steel Products Company.....	61	s National Gypsum Company.....	74	Western Electric Co.....	207
s Dunham, C. A., Company.....	160	National Lead Company.....	53	s Wood Conversion Company.....	165
s Dwyer Products Corporation.....	218	s National Radiator Company.....	196	s Wood Treating Chemicals Co.....	224
Electro Metallurgical Company.....	169	National Tube Company.....	191	s Worthington Pump & Machinery Corporation.....	200
Electromade Corporation.....	37	s Nelson, Herman, Corporation.....	205	Wurlitzer, Rudolph Company.....	183
Employment Opportunities.....	218	Nesbitt, John J., Inc.....	185	s York Corporation.....	209
s Enterprise Engine & Foundry Co.....	188	s New Castle Products.....	222		
Faber, A. W., Inc.....	63	Norfolk & Western Railway.....	163		
Faber, Eberhard.....	30				
s Facing Tile Institute.....	235				
Fedders-Quigan Corp.....	224				
s Fir Door Institute.....	48				
s Fitzgibbons Boiler Company, Inc.....	228				
s Flintkote Company.....	2nd Cover				
Frick Co.....	206				
s General Aniline & Film Corp.....	1				
s General Electric Co.....	180				
General Pencil Company.....	212				
s Goodrich, B. F., Chemical Company.....	42				

NEW YORK—H. Judd Payne, General Manager; Robert F. Marshall, Business Manager; Tom Tredwell, Advertising Mgr.; Benton B. Orwig, Creative Service Manager, 119 West 40th Street; BOSTON—Harry M. Horn, Jr., 855 Park Square Bldg.; CHICAGO—Jack Casey, C. B. Riemersma, 709 Merchandise Mart; CLEVELAND—John C. Jackson, 321 Hanna Bldg.; LOS ANGELES—Bob Wettstein, Room 816, 816 West 5th St.; PHILADELPHIA—Tom Tredwell, 1321 Arch St.; SAN FRANCISCO—Bob Wettstein, 1085 Monadnock Bldg., 681 Market St.

Bright, cheerful, easily-cleaned walls of Facing tile

Architects who design for industry are turning more and more to Structural Clay Facing Tile for interiors in many types of construction.

This colorful, durable, structural material is ideal for cafeterias . . . reception rooms . . . research laboratories . . . first aid rooms . . . rest rooms . . . personnel offices . . .

In beautiful colors, permanently burned in — Facing Tile, glazed or unglazed, can be chosen for any desired effect and, through its cheerful appearance, can help to keep employee morale on a high level.

Sanitary, resistant to grime and dirt, easy to clean — Facing Tile keeps its lustrous looks by simple, inexpensive soap and water washing. It never needs painting . . . is free from costly maintenance!

These are "over-all" advantages architects can point out to *any* industrial company. For certain companies—such as Food Processors, Packing Houses, Dairies, etc.—Facing Tile offers *other* specific advantages. It is resistant to grease, odors, bacteria, lactic acid, steam and stains.

Today, Facing Tile is being produced in the new modular sizes. This assures perfect fitting with other modular materials . . . more flexibility in design . . . less time on drafting and site supervision . . . better workmanship with reduced labor . . . less material waste . . . earlier occupancy.

Registered architects and engineers—See Sweet's 1947 Architectural Catalog or write to Desk AR 5 of the Institute for FREE 90 page Facing Tile Handbook showing methods of determining modular layout procedure. All others send 50 cents. Any Institute Member will assist you.



INSTITUTE MEMBERS

- Belden Brick Company
Canton, Ohio
- Continental Clay Products Co.
Kittanning, Pennsylvania
- Charleston Clay Products Co.
Charleston 22, West Virginia
- Hanley Company
New York 17, N. Y.
- Hydraulic Press Brick Co.
Indianapolis, Indiana

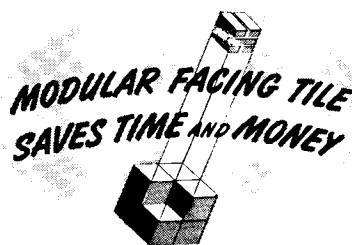

Mapleton Clay Products Co.
Canton, Ohio

INSTITUTE MEMBERS

- Metropolitan Paving Brick Co.
Canton, Ohio
- National Fireproofing Corp.
Pittsburgh 12, Pennsylvania
- Stark Brick Company
Canton, Ohio
- Stone Creek Brick Company
Stone Creek, Ohio
- West Virginia Brick Company
Charleston, West Virginia

FACING TILE INSTITUTE

1756 K STREET, N. W.

WASHINGTON 6, D. C.

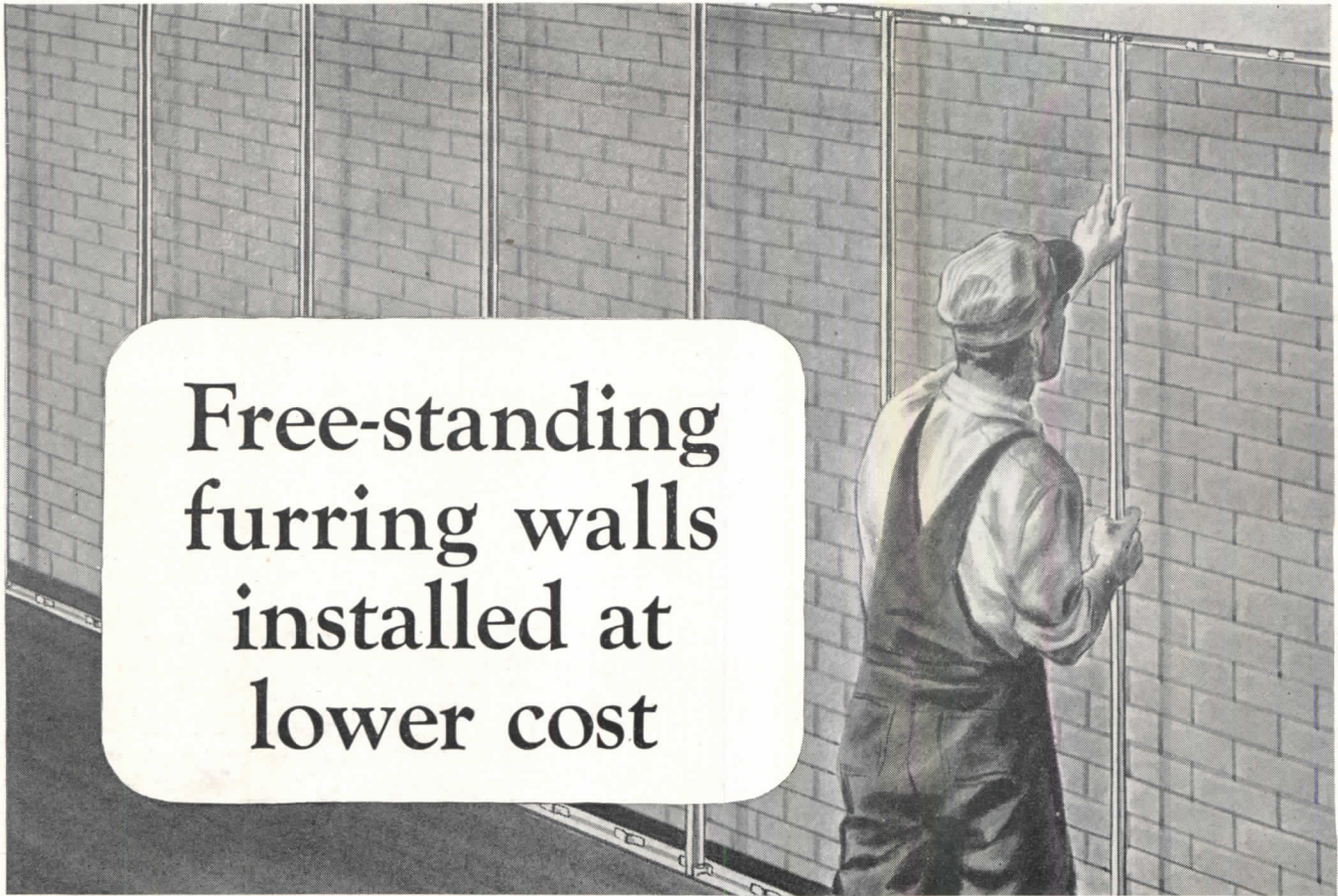

Free-standing furring walls installed at lower cost

...with this quickly-erected Milcor system

The Milcor Furring System improves the mechanical efficiency of erecting furring over masonry walls.

Only *two* separate units—the same ones used to build Milcor Solid Partitions—provide the steel to hold the metal lath: (1) a standard runner which is used at both floor and ceiling; (2) a standard channel stud. Confusion in handling materials is eliminated; time is saved.

The lath wall is a structure complete in itself, from floor to ceiling—plastered one side only. It can be placed at any distance from the masonry wall and in no contact with it; clips and ties to the outside wall are unnecessary for ordinary height. This permits using any type of insulation.

Compared with ordinary furring methods, the Milcor Furring System provides lower first cost and greater flexibility, for such purposes as: (a) concealing service piping and ducts; (b) concealing irregularities in masonry walls and other supporting construction; (c) providing a base for a plastered interior finish of different line and contour than that represented by rough or finished masonry; (d) providing fire protection to structural supporting members, ventilating ducts, etc.

Consult the Milcor Manual in Sweet's Architectural File, for helpful information on the new Milcor Furring System, and the complete Milcor line of steel building products. Write for bulletin on the new Milcor Solid Partition and Furring System.

MILCOR STEEL COMPANY
Inland Steel Products
 MILWAUKEE 4, WISCONSIN

Baltimore 24, Md.
 Cincinnati 25, Ohio
 Kansas City 8, Mo.

Buffalo 11, N. Y.
 Cleveland 14, Ohio
 Los Angeles 23, Calif.

Chicago 9, Ill.
 Detroit 2, Mich.
 Rochester 9, N. Y.

