

ARCHITECTURAL RECORD

COMBINED WITH AMERICAN ARCHITECT AND ARCHITECTURE

Next Month

THE RECORD will end its Fiftieth Anniversary year with a December issue which will prove, we think, just as stimulating and useful as the one which was so well received last January.

Needless to say, it won't follow the same pattern as the January RECORD. For the past 12 months have brought us to the threshold of an all-out war economy. Like every other industry, building has been affected. In January we faced the prospect of a mammoth construction volume; at year's end building opportunities have become fewer under the pressure of material shortages and expanding requirements of national defense.

But the *need* for building is still vital. And we've dedicated December to a survey of that need. What's required today for the "health and safety of the civilian population?" How can America's "defense area" towns and cities care for the structural and technical requirements of an increasing population? How can orderly planning for today—and tomorrow—be organized to replace the confusion of present guesswork? And what part can architects, engineers and builders play in conserving present values, improving urban facilities and upholding for the future the high economic and technical standards of American living?

These are some of the questions for which next month's RECORD will suggest answers. The entire issue will be devoted to such vital subjects. And as the building industry starts to grit its teeth and roll up its sleeves for its second-year defense activity, the December RECORD will present the facts and figures, means and methods in a graphic preview of the job that lies ahead.

VOLUME 90

NOVEMBER 1941

NUMBER 5

NEWS AND TRENDS

| | |
|--|----|
| BUILDING'S PART IS BIG | 41 |
| By H. Judd Payne | |
| HILL, NEW HAMPSHIRE RECREATED—A PRECEDENT FOR PLANNERS | 44 |
| By Anatole Solow | |
| DEFENSE HOUSING—ARE WE BUILDING FUTURE SLUMS OR PLANNED COMMUNITIES? | 56 |
| By Dorothy Rosenman | |
| SMALL HOUSES | |
| Orono, Maine | 59 |
| Seattle, Wash. | 62 |
| Glen Ellyn, Ill. | 64 |
| Tuckahoe, N. Y. | 66 |
| Los Angeles, Calif. | 67 |
| Menlo Park, Calif. | 68 |
| Bethesda, Md. | 70 |



HOUSING FOR DEFENSE...

| | |
|------------------------------------|----|
| A BUILDING TYPES STUDY | 71 |
| PLAN STANDARDS FOR DEFENSE HOUSING | 72 |
| CASE STUDIES | 77 |
| TIME-SAVER STANDARDS | 91 |



| | |
|----------------------------------|-----|
| BEHIND THE RECORD | 7 |
| WITH RECORD READERS | 10 |
| NEWS FROM WASHINGTON | 16 |
| TRENDS IN BRIEF | 22 |
| REVIEWS OF CURRENT LITERATURE | 26 |
| CURRENT TRENDS OF BUILDING COSTS | 37 |
| NEWS OF MATERIALS AND EQUIPMENT | 98 |
| ARCHITECTURE MEETS ADVERTISING | 100 |
| INDEX OF ADVERTISEMENTS | 142 |

Copyright, 1941, by F. W. Dodge Corp. All rights reserved.

Editorial Director: Thomas S. Holden. *Managing Editor:* Roger Wade Sherman, AIA. *Associate Editors:* Frank G. Lopez Jr., George A. Sanderson, Emerson Goble. *Art Director:* Gene Hawley. *Desk Editor:* Catherine Woolley.

ARCHITECTURAL RECORD (combined with *American Architect and Architecture*) is published monthly by F. W. DODGE CORPORATION, 119 West 40th Street, New York. Thomas S. Holden, Pres.; Howard J. Barringer, Vice Pres. and Treas.; Irving W. Hadsell, Vice Pres.; H. Judd Payne, Vice Pres.; Chauncey L. Williams, Vice Pres.; Sanford D. Stockton Jr., Secy.; Walter F. De Saix, Asst. Treas.; Edwin H. Freed, Asst. Treas. Member Audit Bureau of Circulations and Associated Business Papers, Inc. ARCHITECTURAL RECORD is indexed in Reader's Guide, Art Index, and Industrial Arts Index. Subscription rates: United States and Possessions, Canada, Cuba, Mexico, Central and South America, \$3 the year, \$5 for two years, \$6 for three years; elsewhere, \$5 the year; single copy, \$1. *Circulation Manager:* Robert C. MacDougall.

Manuscripts, photographs, and drawings which conform to RECORD'S editorial aims are welcomed. Every effort will be made to return material (if accompanied by stamped, addressed envelopes); but the editors will not be responsible for losses.

Other Dodge Services: REAL ESTATE RECORD AND BUILDERS' GUIDE, SWEET'S CATALOG FILES, HOME OWNERS' CATALOGS, DODGE REPORTS, and DODGE STATISTICAL RESEARCH SERVICE.

**Bellevue Square
Court gets
MORE ROOMS
FOR LESS
MONEY**

*... Thanks to Gold Bond's
2" Solid Partition
System*

ARCHITECTS everywhere are finding the Gold Bond 2" Solid Partition System is the best way to increase floor area and reduce partition costs. Tried and proven in Hartford's Bellevue Square Court—and in scores of other housing projects, apartments, and office buildings—the Gold Bond 2" Solid Partition System increases usable space 7%, provides a fireproof barrier that reduces room-to-room noise, and speeds up construction. The exclusive metal base is easily cut and bent on the job—no prefabrication is necessary—yet this better system costs no more than 5³/₈" wood stud and wood lath construction.

Gold Bond First with the Best
The 2" Solid Partition System with Metal Base is only one of many outstanding Gold Bond improvements. National Gypsum Company's research has developed more than 150

other *better* Gold Bond products—including wallboard, plaster, wall paint, lime, sheathing, gypsum and metal lath, insulation and sound control materials. 21 model plants keep 10,000 dependable Gold Bond dealers supplied with fresh materials. 300 trained Gold Bond representatives are ready and able to help you select the best material for your particular job. And when you specify Gold Bond exclusively, you get the extra protection of having responsibility for *all* products centered with *one* organization, the world's largest exclusive wall and ceiling material manufacturer. **FREE DON GRAF SPECIFICATIONS**, with complete architectural drawings of the Gold Bond 2" Solid Partition System, now in preparation. Write for yours today. Metal Products Division, National Gypsum Company, Buffalo, New York.



NO PREFABRICATED UNITS NECESSARY.
The exclusive new metal base of the Gold Bond 2" Solid Partition System can be quickly cut and bent on the job. Plastering goes faster—and the finished job is more satisfactory.



BELLEVUE SQUARE COURT, HARTFORD, CONN. . . ONE OF THE LARGE HOUSING PROJECTS USING GOLD BOND 2" SOLID PARTITION SYSTEMS. OTHERS ARE:

RAMONA HOUSES
Los Angeles, Calif.

GILMORE HOMES
Baltimore, Md.

HALIFAX COURT
Raleigh, N. C.

RED HOOK HOUSES
New York City

CHAD BROWN HOUSES
Providence, R. I.

RIVERVIEW COURT
Phenix City, Ala.

FELIX FULD COURT
Newark, N. J.

BRENTWOOD HOMES
Jacksonville, Fla.

TINDALL HEIGHTS ADDITION
Macon, Georgia

BUILD BETTER WITH
Gold Bond
Everything—for walls & ceilings

Producing units at:

NEW YORK, N. Y. . . CLARENCE CENTER, N. Y. . . AKRON, N. Y. . . PORTSMOUTH, N. H. . . NATIONAL CITY, MICH. . . FORT DODGE, IA.
MEDICINE LODGE, KAN. . . ROTAN, TEX. . . SAVANNAH, GA. . . LUCKEY, O. . . BELLEFONTE, PA. . . YORK, PA. . . ORANDA, VA.
SALTVILLE, VA. . . NILES, O. . . MOBILE, ALA. . . NEWBURGH, N. Y. . . ALEXANDRIA, IND. . . DUBUQUE, IA. . . DOVER, N. J.

BEHIND THE RECORD

Read—and then re-read—the article headed “Building’s Part Is Big,” that starts on page 41. It’s as frank and realistic a statement of the current building situation as you’re likely to find. The message that it carries is vitally significant today—and it *may* jolt you! But if it does, you won’t be alone. Thanks to the OPM all America is at last being jolted into the needed realization that the status quo is now history and that the phrase “business as usual” belongs, at least temporarily, to a dead language.

But realism has two sides. It’s just as important, we think, to appreciate the background job that building has to do as it is to prepare to live in a world wherein everything is scarce except, as Mr. Donald Nelson put it, “lumber, air and water.” Mr. Robert Moses, New York City’s dynamic Park Commissioner, recently sketched this side of the building picture. And we agree with what Mr. Moses said:

“No matter how much production of war implements is speeded up, it will still be vitally important to keep small non-defense industries in existence and not to deprive them of material, starve them out and drive them to the wall. There will still be urgent demands for local improvements. There will still be equipment and material required to keep state and local governments, utilities and other plants on which civilian existence depends, functioning healthily. There will still be non-defense industries employing millions of men which will close their doors unless a broad view is taken of their place in our economic system.”

The defense housing situation isn’t entirely a new one in this country. During World War I there existed much the same sort of housing demand. But we hope today’s solution to the recurring problem will be better than in the past. A kind of shining ideal of what defense housing communities

might be—had the need been recognized sooner and technical skills employed earlier—is suggested in the story of Hill, N. H., that starts on page 44. As “a precedent for planners” the technical report significantly outlines how a town was planned, developed and built from the raw land, and is proof abundant that democratic enterprise can really do things well.

The story is also an interesting commentary on the fact that such a project can be organized and carried through in the best town meeting tradition of a conservative New England community.

More proof that architects know their way around in housing is paraded in the Building Types study, pages 71 to 90. Many of the defense projects illustrated embody a lot of the technical points developed at Hill. As a

result we’ll prophesy there’ll be fewer war-emergency slums to be cleared, come twenty years from now.

Here’s a letter from Mr. R. A. Heaney, an architectural student in New Zealand, that someone ought to answer, we think, in the spirit in which it was written.

I would very much like to have a pen friend interested in art and architecture, and as your magazine has, I have no doubt, a very large circulation, you may be able to put me on to someone who would be willing to oblige. I would if possible like a young man and a young lady. As you know we are a long way from the center of things and any word from outside is indeed a great help. Your magazines are always a source of inspiration to students in New Zealand. My age is 22, so that may or may not make things easier.

Mr. Heaney’s address is 46 Trafalgar St., St. Albans, Christchurch, New Zealand.

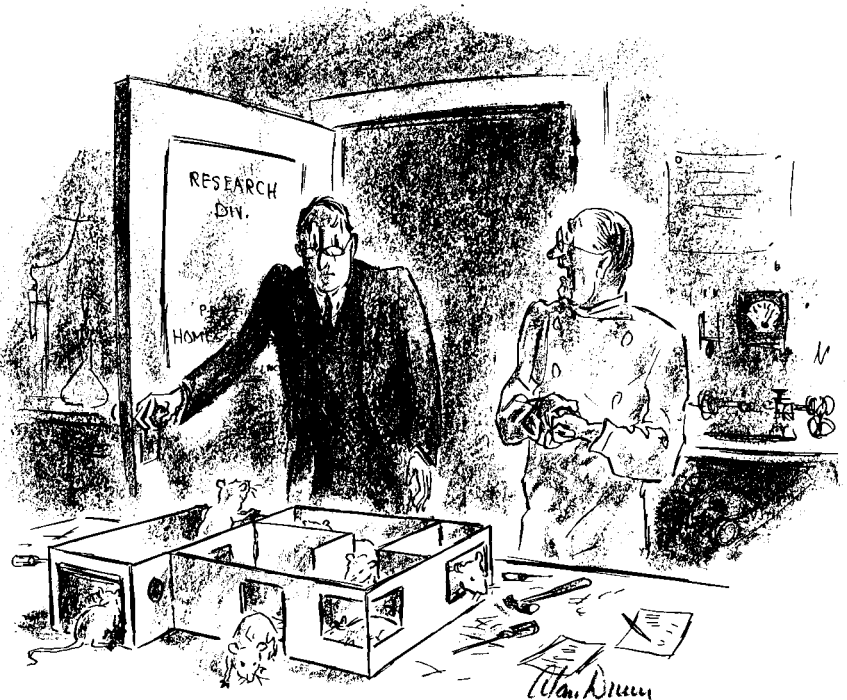

“You don’t need to worry about the next model—I tried it on experimental rats first.”
—Drawn for the RECORD by Alan Dunn

Sloan Flush Valves? -take

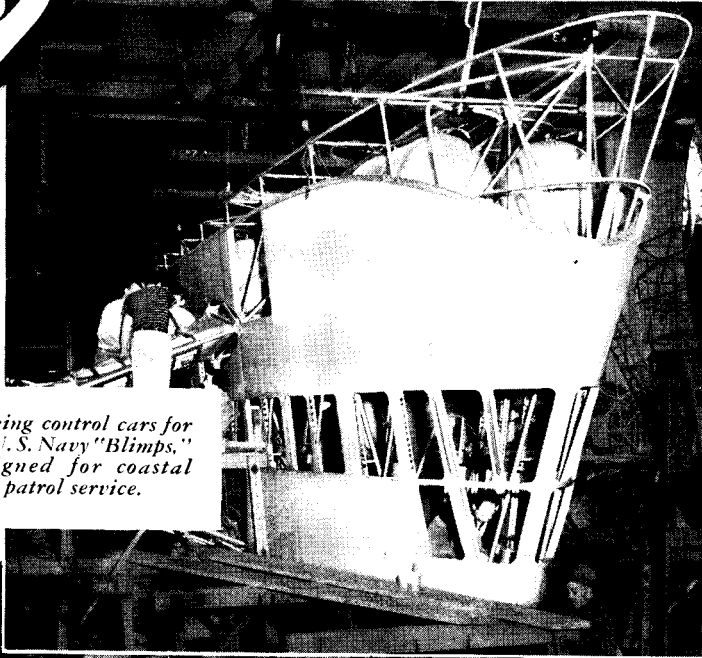

Making control cars for the U. S. Navy "Blimps," designed for coastal patrol service.



View of final inspection conveyors where every Goodyear tire is carefully checked.



General view of Goodyear Plant No. One, Akron, Ohio. In Akron there are three such Goodyear plants besides the airship dock—all Sloan equipped.



America's commercial progress took a long step forward when Charles Goodyear discovered the secret of vulcanizing rubber, back in 1839. From that discovery grew the giant enterprise of the Goodyear Rubber Company which today not only includes rubber goods factories around the world, but seven large textile mills throughout the United States and Canada, plus innumerable district headquarters, branch offices, sales and service stations. It seems most significant that practically all of these factories and buildings are Sloan equipped.

Why Sloan Flush Valves?

WHY should Goodyear, in common with hundreds of other large organizations and institutions, depend almost entirely upon Sloan for flush valves? The answer is simple: Sloan Flush Valves give the greatest dollar value.

THEY SAVE WATER . . . In one installation where Sloan Flush Valves replaced other equipment, there resulted a saving of 50,000,000 gallons of water per year. And of course such a saving means *more* than water; it means saving electricity, coal, man-power. Sloan Flush Valves save their owners money *all* the time because their adjustment stays put.

THEY SAVE REPLACEMENT . . . Sloan Valve durability can be verified in *your* locality. Installations fifteen, twenty or twenty-five years old are common to every section of the country and to every type of building.

THEY REDUCE MAINTENANCE EXPENSE . . . Sloan Flush Valves cost but ½c to 1½c per valve *per year* to maintain. Entire installations in service for years without being touched are constantly reported.

THAT'S WHY . . . In schools, hospitals, office buildings, hotels, institutions, factories, apartments or public buildings, the vast majority of flush valves are SLOAN. Indeed—*throughout the entire building field more SLOAN Flush Valves are sold than all other makes combined.*

S L O A N V A L V E C O M P A N Y
4300 West Lake Street, Chicago

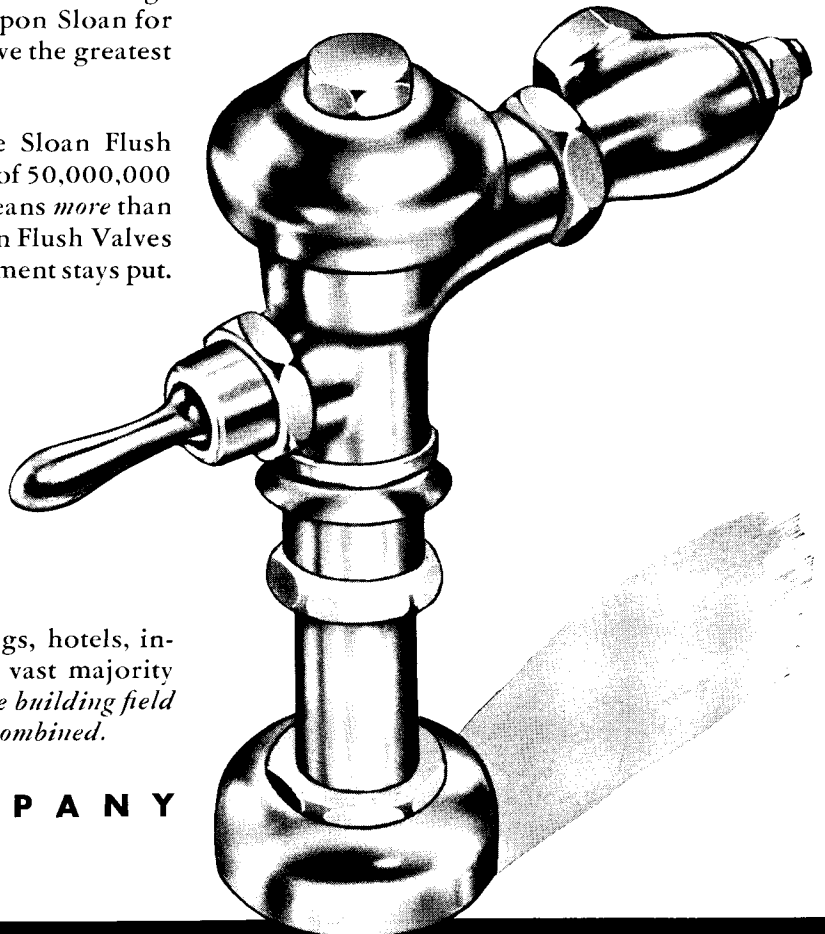

SLOAN *Flush* **VALVES**

WITH RECORD READERS

Architects and Manufacturers Study Standardization of Dimensions

TO STUDY simplification of building construction, through coordination of the dimensions of building materials and equipment; then to recommend specific sizes and dimensions of materials wherever physical properties permit, is the purpose of a joint committee organized by AIA and the Producers Council.

"Coordination," according to an announcement of the committee, which is headed by *Max H. Foley*, New York architect, "makes possible the development of improved manufacturing processes and building methods, and of new materials and constructions.

"Since it is not practicable to standardize the finished building," the report continues, "the broad purpose will be accomplished by the standardization of parts. Certain branches of the building industry have already made important progress in the standardization of sizes for building materials and accessories and, as a result, are now enjoying substantial economies and advantages.

"Further progress has been limited because, by present methods, standardization can be applied only to materials that are readily cut fitted in the field, or to parts that are installed by either the field cutting or the special detailing of materials to which they are attached.

"Coordination will remove these limitations to further progress."

Engineers Organize Defense Board

AN Engineers' Defense Board has been organized by a group of national engineering societies to provide a central agency prepared to assist the various branches of the Government on questions connected with military preparedness.

Technical problems of shortages, substitution, conservation, raw materials, production and reclamation will concern the new body, which proposes to act as clearing house be-

tween engineers and engineering groups, and through committees as a channel of information for engineers.

The group consists initially of five representatives from each of six societies. Executive committee representatives are: American Society of Civil Engineers, *Carlton S. Proctor*, Consulting Engineer; American Institute of Mining and Metallurgical Engineers, *John F. Thompson*, Executive Vice-President, International Nickel Co.; American Society of Mechanical Engineers, *R. M. Gates*, President, Air Preheater Co.; American Institute of Electrical Engineers, *H. H. Barnes Jr.*, General Electric Co.; Society of Automotive Engineers, *C. L. McCuen*, Vice-President and Chief Engineer, General Motors Corporation; American Institute of Chemical Engineers, *F. W. Willard*, President, Nassau Smelting & Refining Company.

Serving as chairman of the Engineers' Defense Board is *Robert E. McConnell*, OPM Consultant.

Awards

ROBERT MOSES was the first recipient of the American Institute of Steel Construction's John Floyd Kimbrough Medal for achievement in steel construction and coincidental advancement of American civilization. The award was made to Mr.

Moses as New York City Park Commissioner in recognition of the achievements of his department typified in the new East and Hudson River drives and other similar developments which by now have made New York a model of urban planning.

* * *

PRIZES awarded by National Jury in the Tenth National Ceramic Exhibition, which is on view at the Syracuse (N. Y.) Museum of Fine Arts through Nov. 16, went to *Karl Drerup*, Rockville Centre, N. Y. and to Mrs. *Ruth Raemisch*, Providence, R. I. for enamels; for sculpture to *Bernard Emerson Frazier*, Lawrence, Kans., *W. W. Swallow*, Allentown, Pa., *Lyman S. Carpenter*, Chicago, Ill. and *Vally Wieselthier*, New York City; for pottery to *Edwin and Mary Scheier*, Durham, N. H., *Don Schreckengost*, Alfred, N. Y., *Gertrud and Otto Natzler*, Los Angeles, Calif., *Edgar Littlefield*, Columbus, Ohio, *Thomas Samuel Haile*, Alfred, N. Y. and *Crucita T. Cruz*, Albuquerque, N. M. The current showing, first exhibition of contemporary ceramics of the Western Hemisphere, is sponsored by the Museum and International Business Machines Corporation.

(continued on page 12)



ROBERT MOSES

TRIBORO BRIDGE
Approach

WANTED!

simple way to be sure of FLUORESCENT AT ITS BEST!

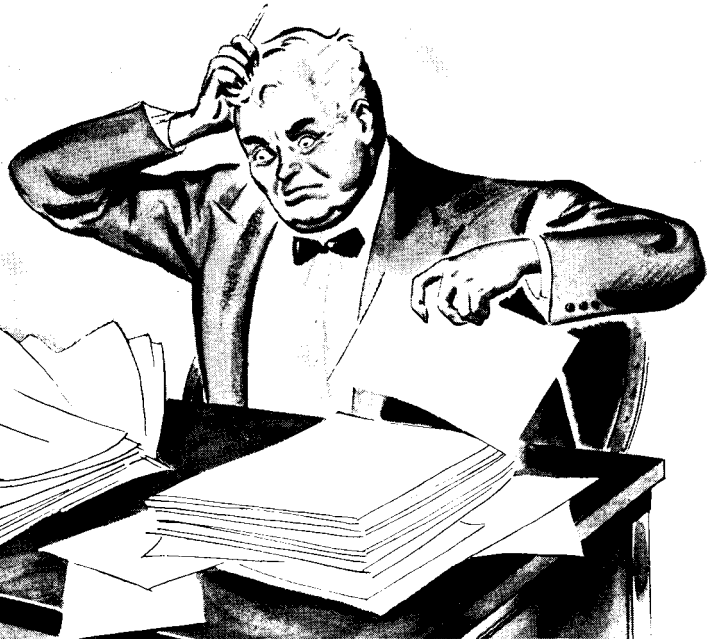

HERE IT IS!

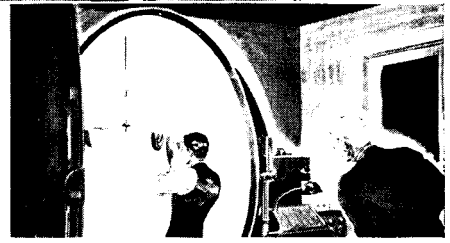
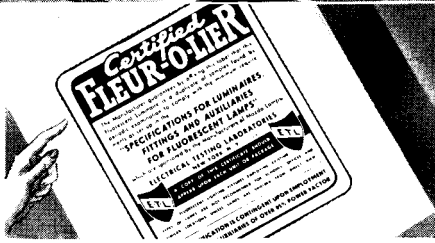
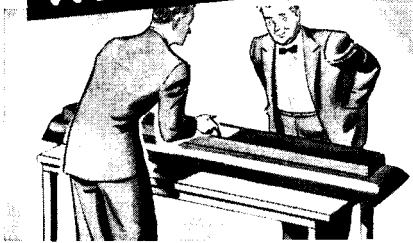

If you've pondered about what kind of fluorescent lighting fixtures to specify for your clients—stop worrying—take this tip. *Look for the label* that marks the Certified FLEUR-O-LIER! You need look no further.

This label is your assurance that famous Electrical Testing Laboratories has *certified* this fixture as having met 50 exacting specifications set up by MAZDA lamp manufacturers to give you good light and safe, satisfactory performance.

For your protection, FLEUR-O-LIERS are tested on such vital points as flicker correction, durability and safety, ease of maintenance, dependable ballasts and starters, efficient lighting performance and high power factor (over 85%).

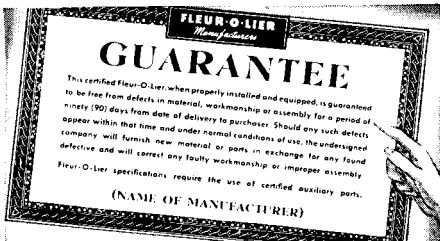

FLEUR-O-LIER means lighting fitted to your specific needs. You have a choice of over 125 different designs . . . in a wide price range, products of over a score of leading fixture manufacturers. And they all carry the guarantee you see here.

**SEND FOR THIS
NEW BOOKLET FREE**

Describes in detail the 50 standards to which FLEUR-O-LIERS are built—shows how many of the tests are made.



Before writing your specifications for fluorescent lighting, find out about Certified FLEUR-O-LIERS . . . fixtures you can recommend with confidence for stores, offices and factories. And check with your electric service company for engineering advice on installing FLEUR-O-LIERS to fit your specific need.

FLEUR-O-LIERS

CERTIFIED FIXTURES FOR FLUORESCENT LIGHTING

Participation in the FLEUR-O-LIER MANUFACTURERS' program is open to any manufacturer who complies with FLEUR-O-LIER requirements

— TEAR OUT AND MAIL —

Fleur-O-Lier Manufacturers • 2152-11 Keith Building, Cleveland, Ohio

Please send me FREE new booklet "50 Standards for Satisfaction," together with list of Fleur-O-Lier manufacturers.

Name

Address

City State

(continued from page 10)

Arnaud Asks Deferment of Architects; Zucker Pleads for Normal Education

FROM two scholars come words of foresight in a chaotic world of the moment. Dean *Leopold Arnaud* of the Columbia University School of Architecture pleads for deferment of architectural students. When active warfare ends, the Dean declares, the amount of building that will be required in this country alone staggers the imagination. He believes the architect's position in the future will be incalculably greater than in the past.

"It would be folly to deplete the profession because of immediate considerations alone," the Dean points out. "There is already a serious dearth of trained men in the architectural field . . . all the more necessary to train young men now for the enormous tasks of both the immediate and near future.

"Judging from available reports, England is still training students in architecture and has placed them on preferential lists. . . . But it is doubtful whether any professional schools are functioning on the Continent, and surely structural activity has ceased. During the immediate post-war years, it seems inevitable that technicians as well as materials will be sought here if the war-ridden countries are to be rehabilitated."

Warns of over-emphasis

Meanwhile Dr. Paul Zucker, professor of the history of art at Cooper Union, warns of possible over-emphasis on defense training in college.

"The spirit of true humanism should be kept alive in art education even during an emergency such as exists in this country today," Dr. Zucker declares. "More strongly than ever, the eternal cultural values of art, the never-changing relationships between human beings, man's attitude toward nature, gradual development of art form, and influence of spiritual ideals should be emphasized."

One Architectural Group for New York?

THE seventy per cent of registered architects in New York State who belong to no organization will shortly be queried by the Committee on Unification of New York Chapter of AIA as to why they don't, and whether they would consider joining a large architectural organization in the metropolitan area which would merge existing groups.

The proposed move was reported by the Committee following a survey of architects in the state. Of a total of 3,535 registered architects, 2,548 practice in the metropolitan area. In this territory there are now 22 professional organizations. A group of 2,000 members, dues \$35, would bring an annual income of \$70,000, it is estimated. At least 50 per cent of this could be devoted to advertising, public relations, other interests of the profession. *Lewis G. Adams* is chairman of the Committee.

California Assn. Shows Air Shelter

AN air raid shelter erected at the California State Fair, Sacramento, by the California State Council of Defense and the State Association of California Architects, Northern Section, was visited by 175,000 persons. The exhibit, believed first of its kind in the United States, represented the type of shelter which British factory owners are required to provide for employees. Thirty feet long, 12 feet wide, eight feet high, it was sunk half underground and covered with two



AIR RAID SHELTER exhibit at California State Fair in Sacramento

feet of earth and sandbags. Corrugated steel provided the lining, sandbag baffle walls gave protection at entrance and exit.

The exhibit was a projection of the Association's new public relations program, which is based on the premise that publicity for the architectural profession is best sought in other ways than through paid radio. Paid radio, according to *Norman K. Blanchard*, chairman of the Public Relations Committee, "does not suit the budgets of not too affluent professional groups." Under the present program the organization employs a professional publicist who works out a plan of public activity.

Local Defense Needs Technical Men

DEFENSE Committees in many localities, faced with possible need for new city planning measures, construction of housing and shelters, remodeling of existing structures, are noticeably without architectural representation and technical guidance. So an appeal from architects on the Massachusetts Committee on Public Safety, appearing in the October *Bulletin* of the Boston Society of Architects, seems to the point. Architects are urged to take the initiative: present themselves to their community Defense Committees and volunteer for services.

Conventions

TO SUCCEED in contemporary practice an architect must understand not only "the problems and instrumentalities involved in current city and regional planning," but also the "fundamentals of modern commercial and industrial management." Such was the dictum laid down at the 14th annual convention, in Hollywood, of the State Association of California Architects. Other requirements for successful practice, "whether or not on a private basis," were seen as: Comprehension of the important is-

(continued on page 14)

TRANE—full speed ahead with Uncle Sam's Fleet

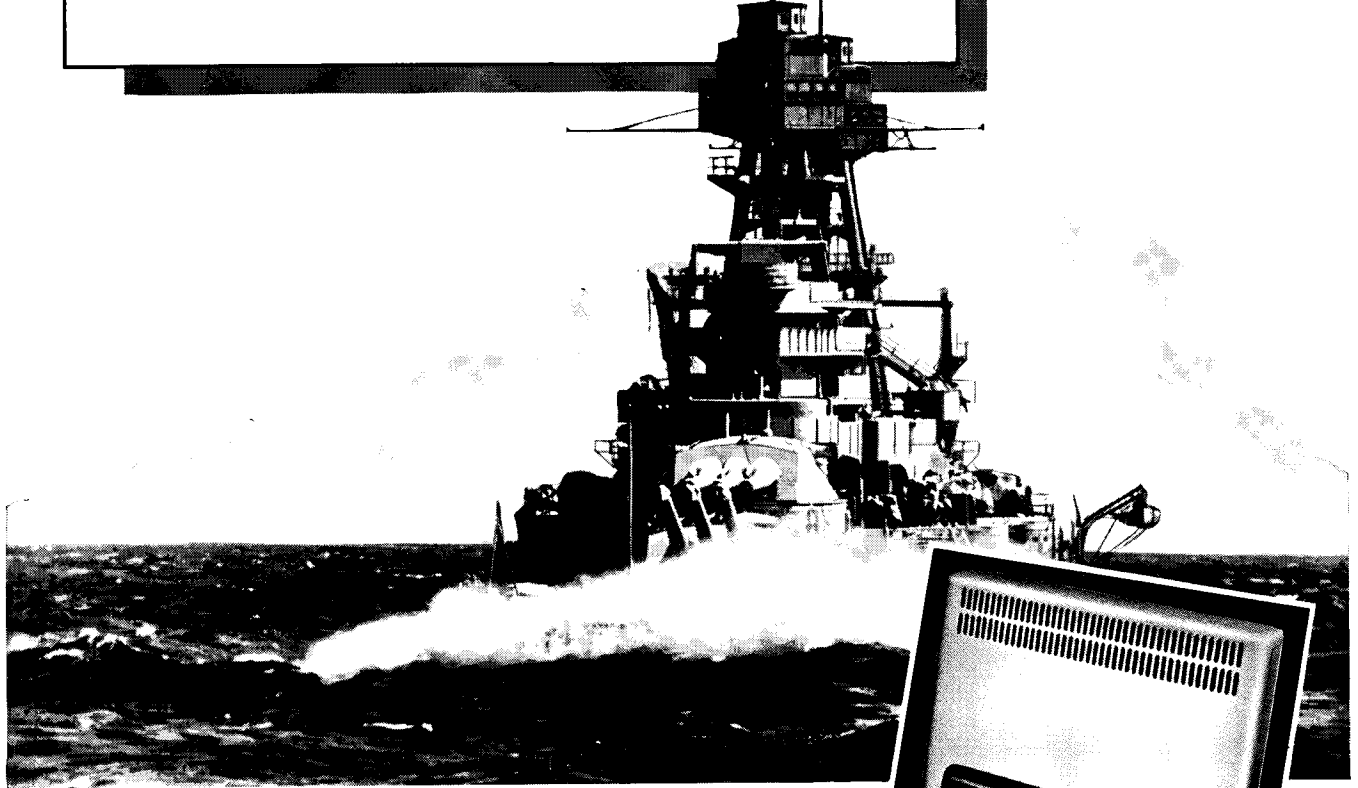

SCORES of vessels in America's first line of defense, the United States Navy, are equipped with Trane Thermostatic Traps and Trane Convector. These vessels include ships of all categories from seaplane tenders and destroyers to the huge new super-dreadnoughts now under construction. Moreover, many of the new cargo vessels for the U. S. Maritime Commission incorporate Trane Blast Coils in their heating and ventilating arrangements.

The Trane factories at La Crosse are geared at a production level to meet the demands of America's armed forces. Trane Steam Heating Specialties, Convectors, and Unit Heaters by the thousand are being installed in army and navy camps, cantonments and air bases throughout the country.

There are 85 Trane branch offices in as many leading cities of America where you will find a Trane representative with up-to-the-minute information to assist you in the solution of your heating, cooling and air conditioning problem with the nation's most complete line of heating, cooling and air conditioning equipment—the Trane line. Keeping in step with America's national defense requirements is Trane's big job of the hour.

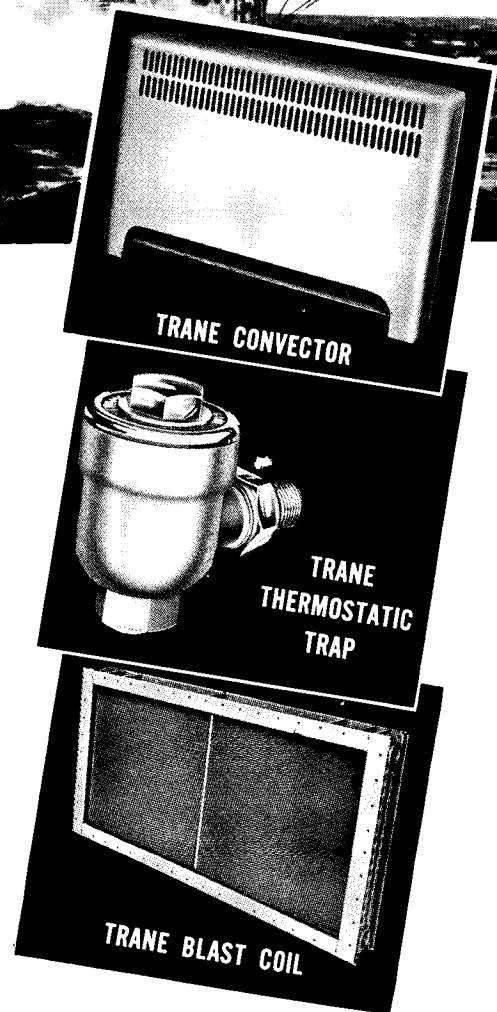

TRANE

THE TRANE COMPANY, LA CROSSE, WISCONSIN • Also TRANE COMPANY OF CANADA, LTD.,  TORONTO, ONTARIO

MANUFACTURERS OF HEATING • COOLING • AIR-CONDITIONING EQUIPMENT • 85 BRANCH OFFICES

STEAM Heats America

Producing heat is only part of the heating job. Putting heat where you want it, when you want it is the big job—the job modern Steam Heating does best. See fact story below. For details write Warren Webster & Company, Camden, N. J.

\$9,000 SAVING IN YEARLY FUEL BILL WITH STEAM HEAT

Wausau School Formerly Known as the largest in U. S. Heated by Warm Air Changes to Steam

USE WEBSTER TRAPS, VALVES

Secure Even, Comfortable Steam Heat in 73 Classrooms, large Auditorium and Gymnasium

Wausau, Wis.—The Wausau Central Junior High School, formerly known as the largest school in the U. S. heated by warm air, is now saving \$9,000.00 a year in coal consumption as the result of changing to modern steam heating in 1936.

"This remarkable saving is only one result of the Heating Modernization," says Frank Kluever, Chief Engineer, Wausau Public Schools.



Wausau Central Junior High School, Wausau, Wisconsin

"Formerly, heating was inadequate. During extremely cold weather, children had to be shifted from one room to another or sent home because it was impossible to obtain a temperature of more than 54 degrees in rooms on the north and west sides.

"Now we are securing even, comfortable steam heat in every section of the building—in 73 classrooms, in our large auditorium, in the gymnasium and in the swimming pool."

Webster Radiator Supply Valves and Thermostatic Radiator Traps are used throughout the School to assure satisfactory steam circulation. The installation also includes Webster Drip Traps and Heavy Duty Traps.

Another important result of the change to modern steam heating is the increased effectiveness of the ventilation system. A relative humidity of 35% can be maintained as compared to the previous 5%, although the same ducts, blower fan and humidification sprays are used.

The Central Plumbing & Heating Co., of Wausau, Wis., acted as modernization heating contractors.

The story of the change to steam heating in the Wausau Central Junior High School was told in NATION'S SCHOOLS for June, 1940. Reprints of this article are available from Warren Webster & Co.

WITH RECORD READERS

(continued from page 12)

sues of our present social order; increasing awareness of the needs, ideals and potentialities of modern living; active interest and ability to participate in important community affairs; a thoroughly practical and imaginative sense of modern construction from the standpoint of the architect's routine rather than that of the engineer; ability to assume his proper role in the expanding industrial processes of mass production in connection with buildings; a ready general working knowledge of modern materials and the latest scientific methods of building equipment.

The convention elected *Wayne S. Hertzka* of San Francisco president to succeed *Walter R. Hagedohm*.

* * *

TEXAS Society of Architects, meeting in Dallas for a second annual convention, heard Managing Director *J. W. Follin* of the Producers Council prophesy that "The more non-defense work that is deferred now, the greater will be the backlog when defense demands are diminishing."

The convention viewed a showing of building materials, and also a photographic exhibit of architectural work by members, which will be sent to tour Texas cities. *Wyley T. Clarkson* of Fort Worth was elected president succeeding *George L. Dahl*.

AIA Names 14 National Committees

MATTHEW W. DEL GAUDIO of New York City has been named chairman of a national Committee on Classes of Membership, just organized by AIA to develop plans for unification of the architectural profession.

Other national committee chairmen appointed include: Present and Future Financial Problems: *James R. Edmunds*, Baltimore. Industrial Relations: *A. C. Eschweiler Jr.*, Milwaukee. Foreign Relations: *Philip L. Goodwin*, New York City. Education: *William Pope Barney*, Philadelphia. Technical Services: *Abraham Levy*, Philadelphia. Allied Arts: *Richard P. Raseman*, Bloomfield Hills, Mich.

Unification: *Leigh Hunt*, Milwaukee. Awards and Scholarships: *Gordon B. Kaufmann*, Los Angeles.

Construction Industry Confers in Capital

CENTRAL theme of the fifth annual Construction Industry Conference in Washington, D. C. Nov. 6 and 7 will be "Construction Faces Defense." Speakers will include *William H. Harrison*, director, production division, Office of Production Management, and *Thomas S. Holden*, president of F. W. Dodge Corporation and Editorial Director of ARCHITECTURAL RECORD.

Personals

PROFESSOR *Ralph E. Winslow* has been named head of the Department of Architecture at Rensselaer Polytechnic Institute, Troy, N. Y., to succeed Professor *Ralph Grady Cully* who resigned to join the faculty of the University of Florida.

Professor Winslow went to R. P. I. in 1930 as associate professor of architecture and was made professor of architectural design in 1931. President of Albany Chapter, AIA, he was graduated from Massachusetts Institute of Technology, traveled in Europe, North Africa and the Near East as forty-third holder of the Rotch Fellowship.

* * *

MORRIS SANDERS, New York architect and industrial designer, has been appointed principal business specialist in construction and design to the Consumers' Durable Goods Section of the Office of Price Administration in Washington. His work will be concerned primarily with alternate methods and materials in the field of consumer goods merchandise.

* * *

JOHN W. ROSS has joined the William L. Crow Construction Company, active in large scale housing and industrial construction, as head of its New Business Department. An architect. Mr. Ross was formerly vice-president of Albert B. Ashforth, Inc.

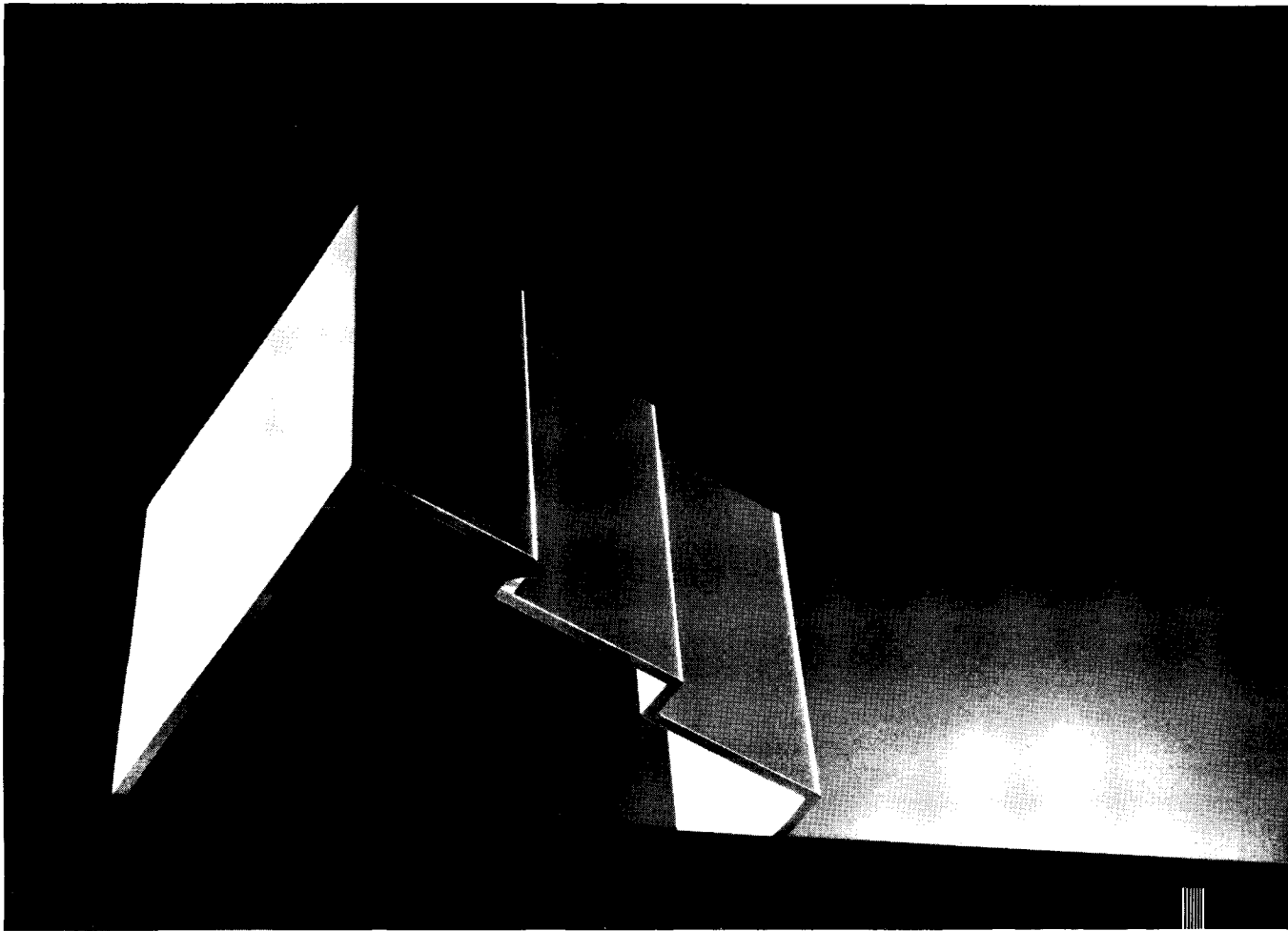

SELF-SUPPORTING

• Pittco Store Front Metal shapes are extruded of aluminum and bronze, with thick, sturdy walls of sufficient rigidity to make them self-supporting. With Pittco members, snug-fitting cores to prevent denting of the metal surface are unnecessary. Were the moulding illustrated above made of light sheet metal, the marks of common abuse would soon be evident upon its smooth, plain surfaces. But when extruded in the Pittco manner, it should retain its original surface beauty indefinitely. This is but one of the reasons why Pittco Store Front Metal is being used more extensively every day by leading architects to meet exacting store front requirements. Pittsburgh Plate Glass Company, Grant Bldg., Pittsburgh, Pa.

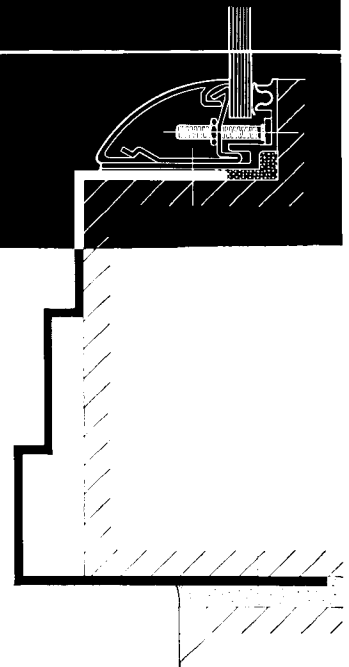

PITTCO STORE FRONT METAL
PITTSBURGH PLATE GLASS COMPANY

"PITTSBURGH" stands for Quality Glass and Paint

DETAIL

Recently, for the frame of a store front and door, an architect desired a moulding severe, plain and bold in character. He selected this Pittco PX 155 as the shape which best fulfilled his specific requirements.

COLLABORATION ON DEFENSE BIDS IS HOPE OF ARCHITECTS

Private building on ice . . . Defense housing reorganization . . . New code standards . . . Rent control . . . Labor a hot spot. —By KENDALL K. HOYT

THE DOUBLE OR NOTHING policy for all-out defense marks an abrupt transition from the slow squeeze felt thus far by the building industry to a very drastic curtailment of all construction work not directly related to national defense.

The recent crack-down by SPAB does not, of course, serve a stop order on work under way, nor does it necessarily prevent the undertaking of new construction. It does not prevent a materials dealer from selling whatever he may have on hand to anyone he cares to supply. But the dealer cannot restock any critical materials other than those he can prove were sold for defense purposes.

That means particularly steel, brass, bronze, aluminum, and likewise copper, which is practically out of the picture now for all non-defense uses. The order affects public projects such as post offices and roads; industrial construction; commercial buildings; and all classes of civilian housing. Work essential to health and safety alone is excepted.

Construction in 1942

Officials explain that they had to take action because civilian construction was diverting too much of the vital materials away from defense. With bootleg materials available at fancy prices and with many projects which could be deferred to take up the slack in business activity after the war, the new priorities regime had no choice but to act.

According to OPM estimates, construction in 1942 will be reduced by 25 per cent, including a decline of 200,000 residential units. Total construction during 1941 will probably reach about \$11.2 billion, about equal to the previous highs in 1926 and 1927. Of this total, \$4.9 billion is defense construction, or about 5 per cent. In 1942 it is expected that the total volume will be about \$8.5 billion, of which defense will make up

75 per cent. Thus non-defense construction will drop from \$6.3 billion this year to about \$2.1 billion in 1942, government economists predict.

It is to be remembered, however, that such items as cement, brick, and other building materials are not yet on the critical list although shortages exist in some areas. There will be many opportunities for architects to use their ingenuity in planning work which can still go forward. Many workers have greatly increased their income but face the outlook of future taxes, inflation, and restrictions on consumer goods which they can no longer buy. Any present building, with provisions for later installation of features involving critical materials, will invest the present dollar in something solid.

Industrial conservation

Government work to prevent waste and conserve materials in all fields has been consolidated under a new Bureau of Industrial Conservation, in OPM, headed by Lessing J. Rosenwald, former Board Chairman of Sears, Roebuck & Co. Overall policy is to serve military needs first but keep the civilian economy in working order.

Work of the new Bureau will include revision of government specifications, avoidance of waste in industrial practices, promotion of the use of substitute materials where available, and the elimination of all non-essential uses of materials where shortages exist or are imminent. The Bureau is asking the cooperation of State and local agencies and affected industries. It will work closely with the National Bureau of Standards and the commodity branches of OPM.

Some 70 Federal specifications already have been revised to effect savings in critical materials. Canteen equipment, defense housing work, laundry equipment and refrigerating equipment are among schedules changed.

Relaxation of some of the existing plumbing code standards in defense housing is especially to be noted. In some cases, critical materials have been ruled out altogether and replaced by substitutes. In others, only limited quantities are permitted. Local regulatory bodies are being urged to pass enabling legislation for use of the revised standards through the emergency and it is hoped the same rules will be applied to civilian housing. It is emphasized that the relaxed standards are only temporary and that they will not impair safeguards to public health.

Priorities ratings

Architects in doubt as to procedure in getting materials for defense projects should write the nearest OPM office for a copy of the Priorities Division application form for defense housing materials. Preference ratings may be assigned either to the builder or his supplier. The builder may apply the rating only to the specific kinds and quantities of defense housing materials applied for on Form PD-105. The priorities order (Preference Rating Order No. 55) may be cancelled immediately if materials are diverted to other uses.

For industrial maintenance and repair materials, an A-10 priority rating is available. But it is stipulated that assistance in obtaining repair parts cannot be used until the producer's inventory and stores of the same class of materials have been reduced to a practical working minimum. Misuse of the plan will result in direct punitive action.

It is expected that aid will be given for completion of projects now under construction but no definite plan has been announced. There will be no help for work begun after the SPAB order.

For architects?

It is evident, amid all these complications, that the architect on private construction work is likely to be in a tough spot the next few years unless he is able to tie in with defense

(continued on page 18)

BUILDING'S PART IS BIG BUT its relative
importance to all-out defense depends on the way
designers, builders and manufacturers use their
ingenuity in meeting the problems posed by scarcities

For the first nine months of the current year, construction contracts awarded for new building were the greatest for any year since 1929. In the 37 Eastern states alone, these awards totalled over \$4,500,000,000.

Building on such a scale has made business good for most who have a part in America's greatest industry. It has made business so good, in fact, that many of us have failed to realize our nation has been at war.

That is an ugly fact. But it is a fact. And if its implications to the future of building have not been driven home by the SPAB order of October 9, there will be no question of its implications when the provisions of the copper restriction order of October 21 become felt.

ARCHITECTURAL RECORD believes it is high time that all concerned with building should become realistic about what a program of all-out defense means. "Building as usual" has gone by the board. "Building for defense" assumes new importance.

Self-preservation for many with a stake in building hinges, the RECORD is convinced, upon realism *now*—not later—in appraising what the individual architect, engineer, manufacturer can and must do if he is to be simultaneously a good citizen and a wise business man.

Building itself will be big in 1942—but big only in proportion to vital defense needs. OPM believes that we will find vital need for another billions dollars of industrial plant and warehouse structure; for two billion dollars worth of housing; for close to half a billion of farm building; for four hundred millions of commercial structures and hospitals

By **H. JUDD PAYNE**, Vice-President,
F. W. Dodge Corporation,
in charge of Magazine Division

YOUR COUNTRY AND MINE is waging an undeclared war. As a nation we are committed to a program of all-out resistance to the spread of dark-age despotism in today's world. To implement this resistance, we have undertaken obligations, as a nation, to Britain, to China, to Soviet Russia. We have simultaneously shouldered the job of welding the Western Hemisphere. These obligations call for the production and delivery of all that may prove needful to feed our allies and to stabilize their economies and to outfly, outshoot, outship the forces of Hitler and his minions.

Hitler's German economy is devoting 70 per cent of its resources to war. The resources of countries he has conquered are systematically being converted to the same end. Should Britain fall, he could, it is said, build ships six to eight times faster than can the United States.

In this country, after more than a year of tooling up for defense, we were devoting about 15 per cent of our resources to defense production on October 9.

The time has come to face a stark, unvarnished reality: Unless Democracy can out-produce the Axis in the next two years our world faces a long, long struggle of attrition with undreamed-of sacrifice and suffering.

Those in charge of waging our undeclared war have concluded that our surest chance to win is to go all-out now. As Donald Nelson, executive director of the Supply, Priorities and Allocations Board, puts it: "That involves setting our sights much higher than we have ever set them before. It involves imagination and preparation that will enable a people to tackle a job bigger than their dreams. Roughly, you might say it involves figuring the utmost we can do—and then resolving to go ahead and do twice as much."

—H. J. P.

and schools. ARCHITECTURAL RECORD believes that off-continent building in 1942 will run four to five times greater than that of 1941. In addition, OPM is projecting plans for all possible modernizing and rehabilitation work that will produce additional family accommodations in defense areas.

But big as building will be in 1942, it will be different. Scarcities of metals will demand that. It will be heavily concentrated in defense areas, of which 275 now exist. It will be almost completely dominated by government. By and large, non-defense projects, private and public will go by the board.

Opportunities for architects and engineers will be fewer—but more challenging. ARCHITECTURAL RECORD endorses in principle the Public Works Reserve project now in progress under co-sponsorship of the Federal Works Agency and the National Resources Planning Board. It regards the legislative proposals to provide adequate financing for long-range coordinated planning as hopeful signs that future construction needs are being recognized. Such financing would provide for making project plans throughout the nation for jobs to be executed in the post-war period—and would call for the services of architects and engineers in goodly numbers.

Such an activity as this not only would be an immediate godsend to architects and engineers—but it would yield a springboard for needed building upon return of normal times.

Furthermore, many point to a need in every locality for developing means for air raid protection and other civilian defense. Architects in Boston, Washington, New York and other localities are at work. Britain is sorry today she didn't sooner realize how much architects could contribute to precautions against loss of life and property in the face of total war.

And, in the aggregate the nation's defense construction program calls for almost as many man hours of planning as did our total building program in 1940. In the face of scarcities and a tough time equation for needed building, the skilled architect and engineer have a vital contribution to make.

Greatest challenge to building—to designers and to manufacturers—that the RECORD sees ahead, is to outdo the Indians who built pueblos of adobe!

Nails are likely to be scarcer before they become more plentiful. While the steel situation is less critical than that of copper, OPM foresees a steel shortage in 1942. The copper restriction order literally removes copper from our non-defense production system except for a very limited amount of wire.

But we have lumber. And glass. And clay products. And adhesives. Yes, and lots of other items that pioneers didn't have when they set out to provide habitation in the wilderness.

The challenge to building is to build without metal. It sounds fantastic!

In 1809 when French armies were ill and starving because of lack of fresh food, the French government set up a prize to the individual who could do something about it. Canned and preserved fresh food resulted. Sounded fantastic, but the problem was licked!

To carry forward essential and non-defense construction with maximum effectiveness, we need more economy in use of metals. There is need for revising existing codes, conventional plans and conventional construction methods. Unless we can learn to build usefully with far less metal, unless building meets its test, the national economy will receive a severe wrench, our standard of living will fall, civilian and armed force morale will be gravely depressed.

Experts who head our mobilization for all-out defense see metal needs for armament and munitions spiraling upward. They see these needs so critical that consumer goods production of all kinds may well be cut in half. They see thousands of non-defense goods production enterprises starved to the point where devastating dislocations of our normal economy seem inevitable. They see non-defense industry unemployment in the offing.

Yet all know good civilian morale in a crisis demands that breadwinners in our body politic have an opportunity to earn bread.

Several million American families depend for bread upon building.

Thus, if in an emergency we can build to a vastly larger extent with the stuffs that are not needful for ships and shells, for planes and bombs—all stand to gain.

Defense industry workers are going to have to work harder, longer each week. Housing for them—not yet adequate—is not enough. They need schools for their children, hospitals for their sick, movie theaters for their precious relaxation hours.

Enlisted personnel—and their families—need decent facilities for shopping, for recreation, for worship in communities close to cantonments.

Health and safety considerations call for much building of many kinds that already is overdue in countless non-defense areas.

But the cold, hard truth is that when a given pound of copper is needed for a shell and at the same time for a house in a non-defense area, it will be put into the shell. Most patriots would have it so.

Suppose that an average conventional \$6,000 house calls for 144 pounds of copper, 2 tons of steel.

Are we ingenious enough to design a livable house that contains no metal? The Indians did it. The pioneers did it. And that was before the era of kerosene lamps, or of gasoline stoves, or of built-up roofing.

Suppose we can't quite do it. Can we get along with 200 pounds of iron, 14 pounds of copper? That would mean under a given metals allocation 10 times as many houses, 10 times as much work, factory wheels behind many building products turning 10 times faster.

Fantastic? No!

Essential building volume in 1942 will be big. Actual building can be bigger to the extent that realism, research, ingenuity, and the will to pioneer mark your efforts and ours in the trying period that lies ahead.

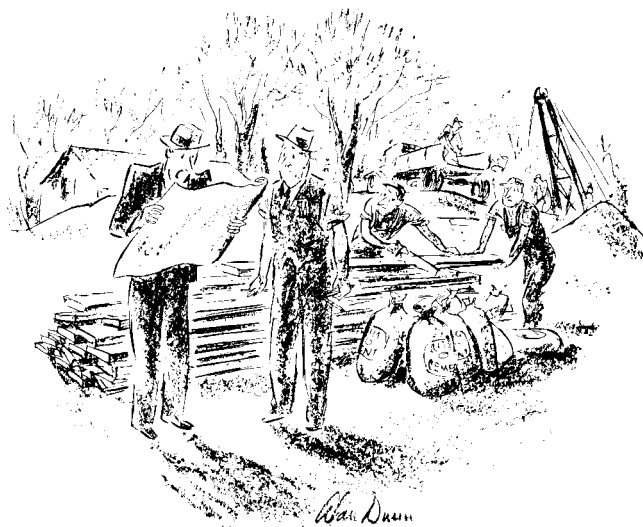

"What the hell! The specifications call for aluminum, copper and nickel!"

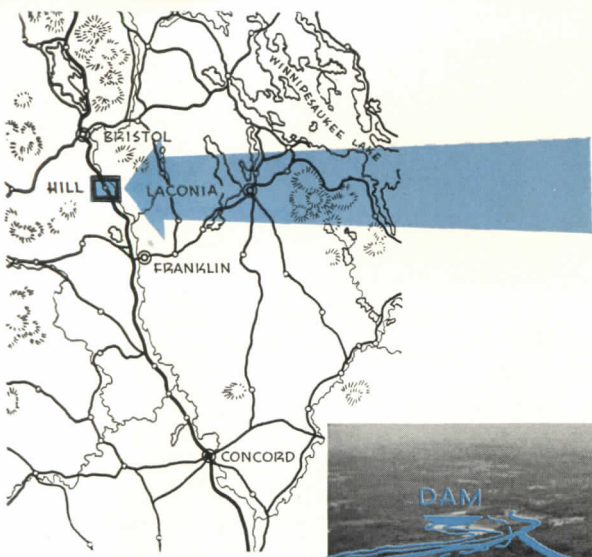

HILL, N. H. RECREATED—

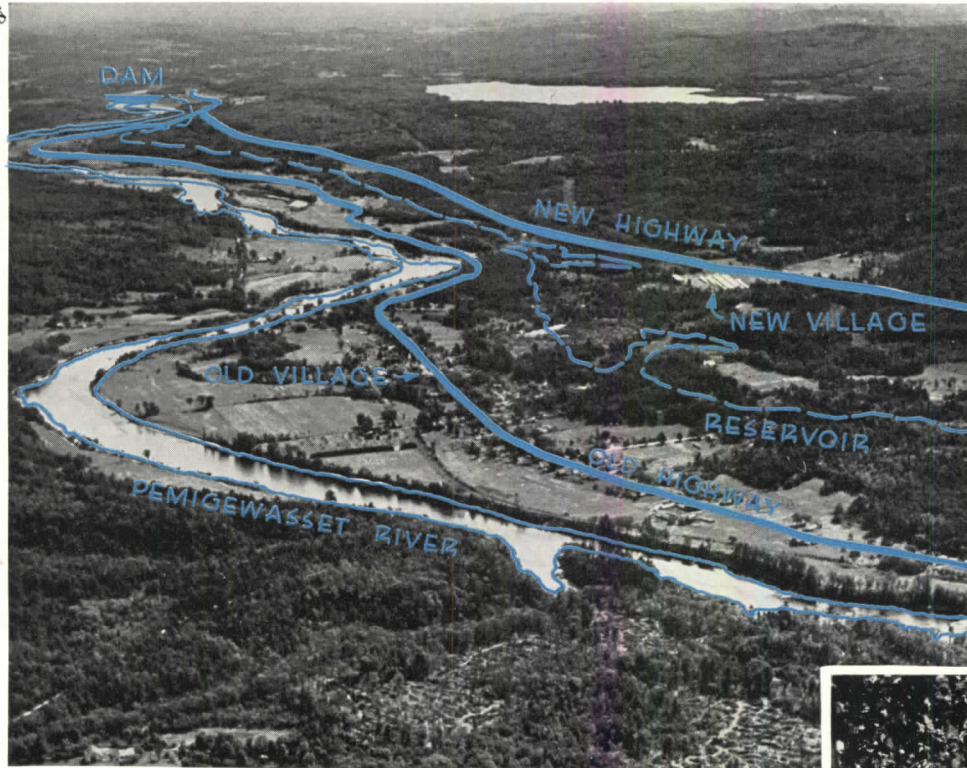

Victor Solow



1. THE BEGINNINGS

THE OLD VILLAGE on the Pemigewasset River, a tributary of the Merrimac, is within easy driving distance of New Hampshire's principal manufacturing and recreational centers. Vacationists travel Route 3A through Hill. The township's population increased slowly from its first settlement in 1768 until 1900, then shrank as urban migration set in. The depression checked this trend, and in 1930 the township consisted of 486 persons, or 120 families, of whom three-quarters lived in the village.

Although rural in character, Hill's economy is reasonably well balanced. No one income-source dominates: farming, varied local and adjacent city industries, local businesses, the tourist trade—from these is derived an average family income of slightly less than \$1,500 per year. On this a Hill family lived a typical, even comfortable, American village life. Taxes weren't too high; there was always a good argument available, political or otherwise; some folks heard rumors of a dam, but everything seemed normal.

FEDERAL FLOOD CONTROL hit Hill as effectively as a demolition bomb. The Merrimac's 1936 floods led to a Federal flood control program; and in 1938 a dam at Franklin Falls, to control the tributary Pemigewasset about 20 miles north of Concord, six miles south of Hill, was authorized. The reservoir to protect downstream cities would engulf the upstream village. The Federal Government promised just compensation for individual and communal facilities.

-A PRECEDENT FOR PLANNERS

By **ANATOLE SOLOW**, Member,
American Society Planning Officials,
Associate Member, Town Planning
Institute

The following consultants, architects and engineers are responsible for the village plan and community facilities: Master Plan, **FREDERICK P. CLARK**, Director, N. H. State Planning and Development Commission, Consultant, **H. C. PERSON**,* Eng., **C. A. BLESSING**,* Archt.; Town Hall, School, **WELLS, HUDSON & GRANGER**, Archts.; Business, Industrial Buildings, **C. A. BLESSING**,* **A. V. EVANS**,* Archts.; Parks, Playgrounds, **S. J. TANI**,* Landscape Archt.; Water System, **HAYDEN, HARDING & BUCHANAN**, Engrs.; Streets, **W. H. ERICKSON**, Engr.

*Of the staff of New Hampshire State Planning and Development Commission.

DEMOCRACY is perhaps the most arresting thing about the relocated, recreated village of Hill, New Hampshire. Who would expect hardheaded, forthright Yankees to fall for a vision? And, particularly in this day of super-vision, who would expect them to start, and remain, free of paternalism?

Hill is not gigantic, not in a country of dollars by billions for defense, dwelling units by thousands for housing. It is a tiny rural community; in its previous existence it had possibly seen its best days. It was not physically prepossessing. But as Hill shows what can be done when the independent American spirit applies itself, with professional help, to hacking out an abode truly in the wilderness, it is tremendous.

Maybe Hill is valuable, too, as a response to some super-planner's despairing cry that democratic processes impede progress. And if those processes, so necessary to the whole project, result in stringencies in parts, the fact must be accepted. Family incomes are low, and every family in the new village is erecting a home. Few individuals could afford their own architects. However, Hill citizens have a right to be proud of the homes they've built themselves; and even those taken from magazines or planning bureaus are in some degree architect-inspired. To deny Hill the right so to plan would have been to deny it a community existence.

In Hill, then, the designer's principal sphere embraced the overall plan and community facilities. In such larger work may lie one form of salvation for the planning professions: the opportunity, here excellently realized, for active collaboration between architects, engineers, landscape architects, and town and regional planners. If community planning can affect people as personally and as favorably as it does in Hill, it is not a small opportunity.

As defense housing, Hill is possibly of slight specific worth. But the principles of community planning for economy, of fostering a pride which leads to continued values, might well be applied to any housing project. —THE EDITORS.



T. Ellis—All photos of Hill courtesy N. H. St. Pl. & Dev. Comm.



Concord Daily Monitor (Anderson)

MARCH, 1939: Town meeting votes unanimously to preserve Hill

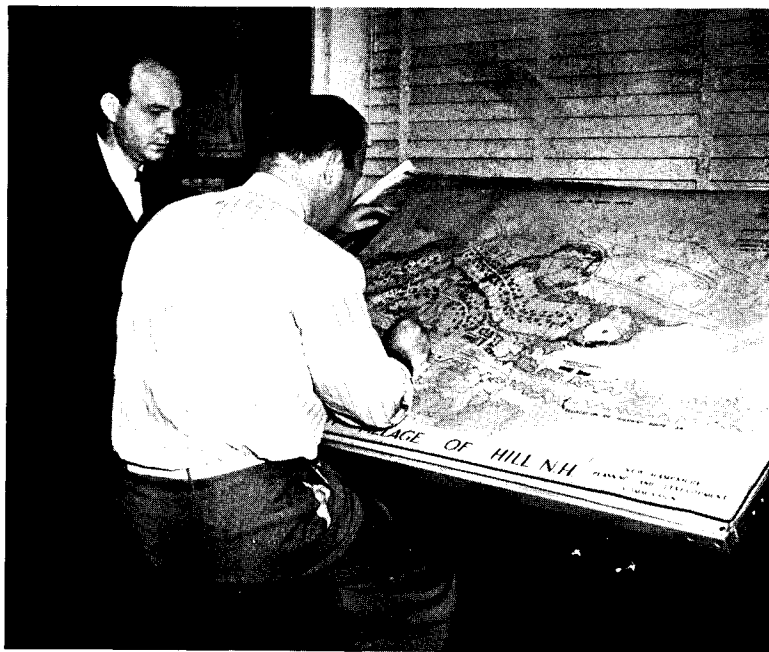

NOVEMBER, 1939: New site selected, design well under way

2. HOW THE COMMUNITY PROCEEDED

PLANNING

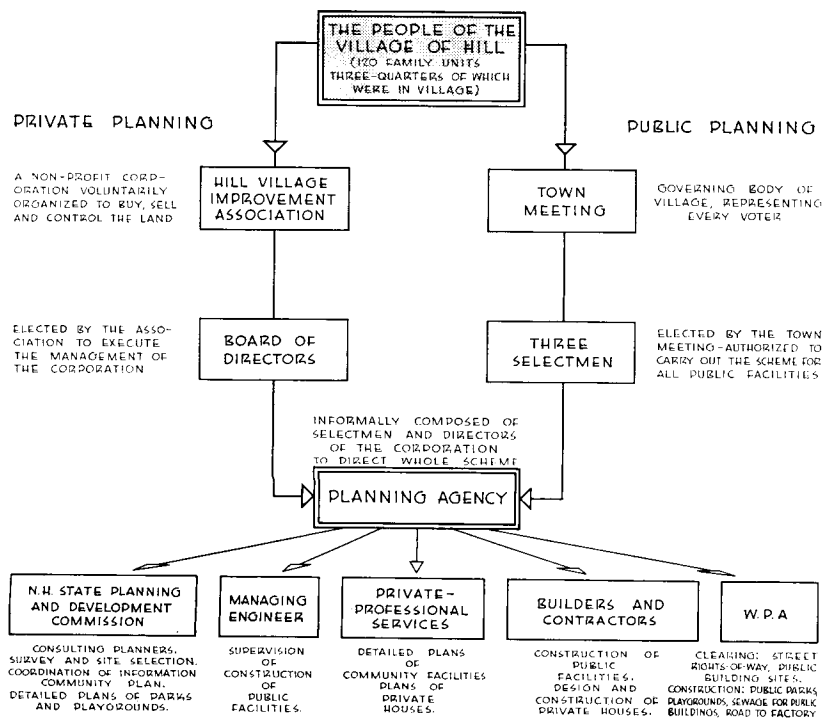

WITH DESTRUCTION of their village inevitable, the people of Hill faced three alternatives:

The community might die. Each family could take its share of federal compensation, break all ties, and establish itself anew in any community.

Hill might be reestablished in the old pattern, loosely organized, unplanned, uneconomical to administrate; attractive, if at all, only as passing years might enhance it; unsafe from both the present motor age and from future developments.

The village might attempt regeneration to maintain its identity in a new location and, by conscious planning, improve the environment it afforded its citizens.

THE PEOPLE CHOOSE

Before Hill could make a choice, several questions had to be answered: Would compensation for old community property be adequate for constructing new facilities? Could a suitable site be obtained? What kind of town could they afford?

Town officials turned to the New Hampshire State Planning and Development Commission. After examining such questions as: Did Hill deserve a chance to continue—economically, socially—as a community? What did Hill want, anyway—



MARCH, 1940: Work on new site under way

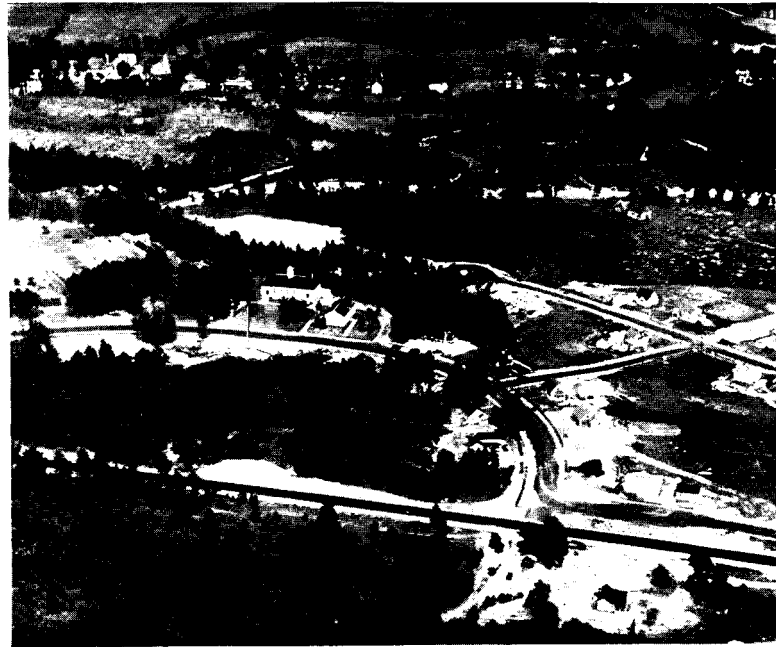

MARCH, 1941: Nearly complete; by midsummer, many houses were occupied

and what should Hill, ideally, have? Were the two sets of wants compatible?—the Commission presented its report to the people of Hill.

At a Town Meeting—New England's traditional form of municipal self-government which gives every voter a direct voice in town affairs—Mr. Clark, spokesman and Director of the Commission, expressed belief that reestablishment was practicable, and that a soundly planned community was the only kind Hill could afford. It was made abundantly clear that this was Hill's own undertaking. The Commission would advise; it would neither think nor decide for Hill. No one would subsidize Hill. Success would depend entirely on Hill's citizens. The Town Meeting voted unanimously to refound the village as a planned community.

No coercion was exercised, either in the beginning or during the long process of planning and rebuilding. To date this consciously adopted policy has had these results: Community spirit has grown from its usual apathetic state to an aggressive force, has even convinced doubting Thomases within the village; continuing personal pride in the project's actual development not only carried it through early struggles, but has also subtly changed the lives of Hill's citizenry. Perhaps most important, this aroused civic consciousness seems to assure Hill's continued success.

FINANCIAL

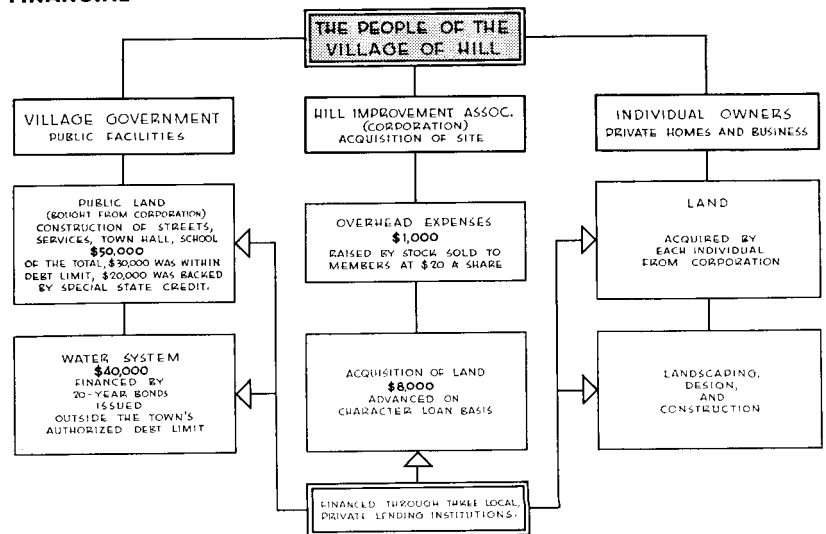

THE PEOPLE ORGANIZE

As a planning agency. Hill created the two-fold organization charted at the left. The State Commission, be it noted, had no official voice in planning. As a body, and in the persons of several members of its technical staff (Messrs. Clark, Blessing, Tani, Evans, Person) who were lent to the village as private consultants, the Commission made its resources available.

Financially, the situation could likewise have led to domination by interests. Work began before final settlement with the Federal Government. The legal debt limit under New Hampshire law is three per cent of assessed valuation, but the State, in anticipation of compensation due, guaranteed Hill borrowing in excess of its debt limit, and local lending institutions were glad to participate as charted above.



Bernice T. Perry

CHARACTER EMERGES

THE OLD VILLAGE (only a portion of the township) stretched thinly along old Route 3A, with 88 homes, 12 businesses, 6 industries, 2 churches, a town hall and a school, on about 240 acres. It possessed a certain charm, due partly to haphazardly picturesque obsolescence, partly to the state of gentle desuetude into which the old, though hardly historic houses had fallen. It possessed several disadvantages.

Contrast with ribbon development straddling the highway—shown in the air view of old Hill at left—the organization of new Hill (right). A day before the 1939 Town Meeting, in the old village, a child was run over. In the new village, heavy traffic is speeded along safely. Old Hill had no center, civic or otherwise, on which to focus in plan or spirit. There, too, ostentatious commercial development squatted between home and home.

3. FROM HAPHAZARD TO CONSCIOUS PLANNING

Victor Solow



AREAS FOR PLAY—

PERHAPS MOST CHARACTERISTIC of changed conditions, the simple pole-roofed play shelter is one of the few picturable expressions of the townspeople's changed attitude toward their town. Though in the heart of a vacation state, old Hill had virtually no public play spaces, no incentive to enjoy the outdoors within its own limits. Now, to reinforce the porch rocker and the Saturday night dance, Hill possesses and uses this children's shelter, pool, game courts and playfield, all convenient to the school, and a separate adult athletic field. Sulo J. Tani was the Landscape Architect.

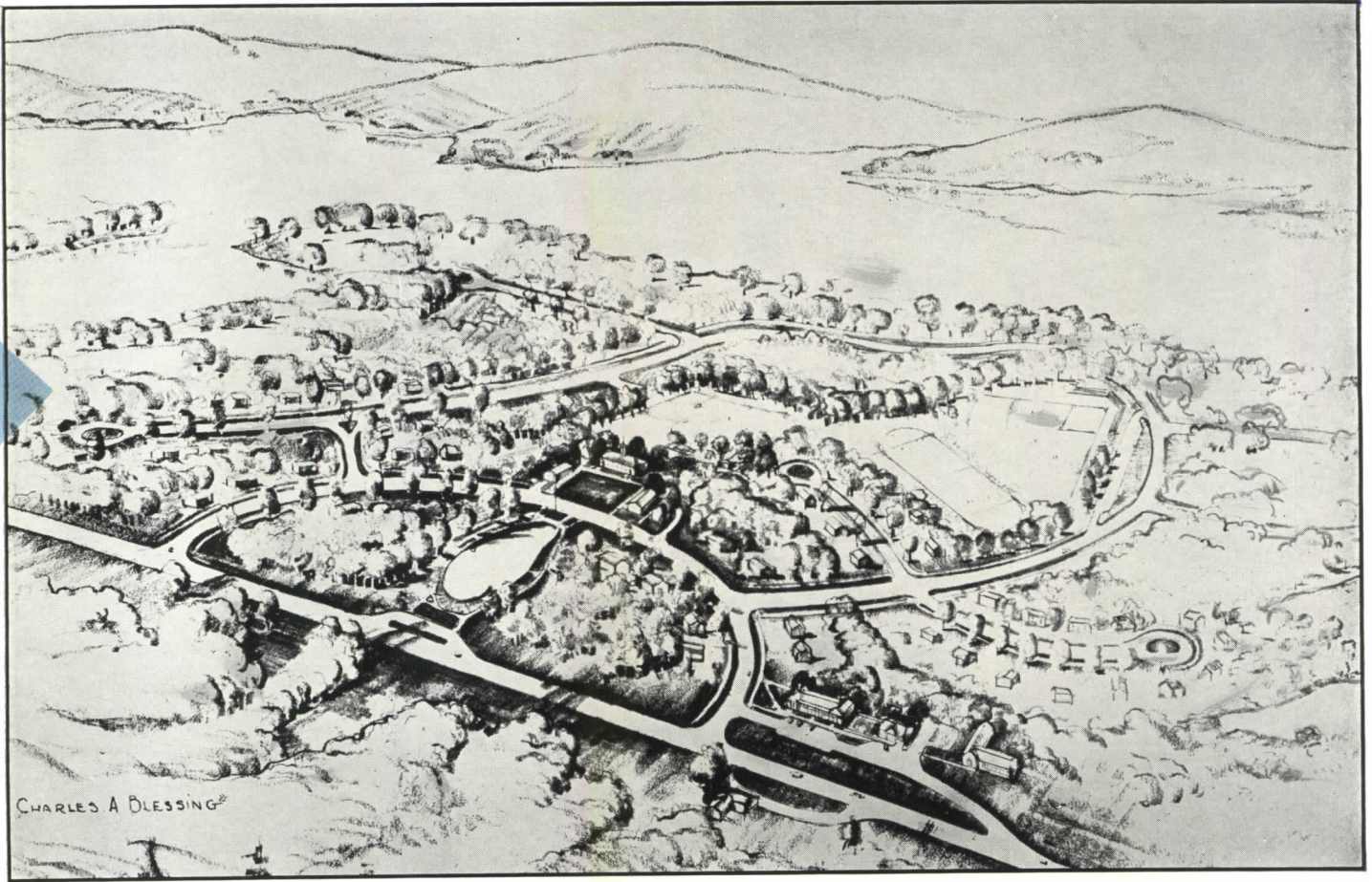

—AND USEFUL HOMES

LIKE THE TOWN HALL, the homes in old Hill were unsatisfactory. But whereas the town hall was much too small, the houses were too large. Built for the most part in the last century, they were designed for families far larger than today's average household, and measured by today's standards they were uncomfortable, they lacked equipment. Houses on the new street below are sized to the families, well equipped, set well back on comparatively spacious half-acre lots.

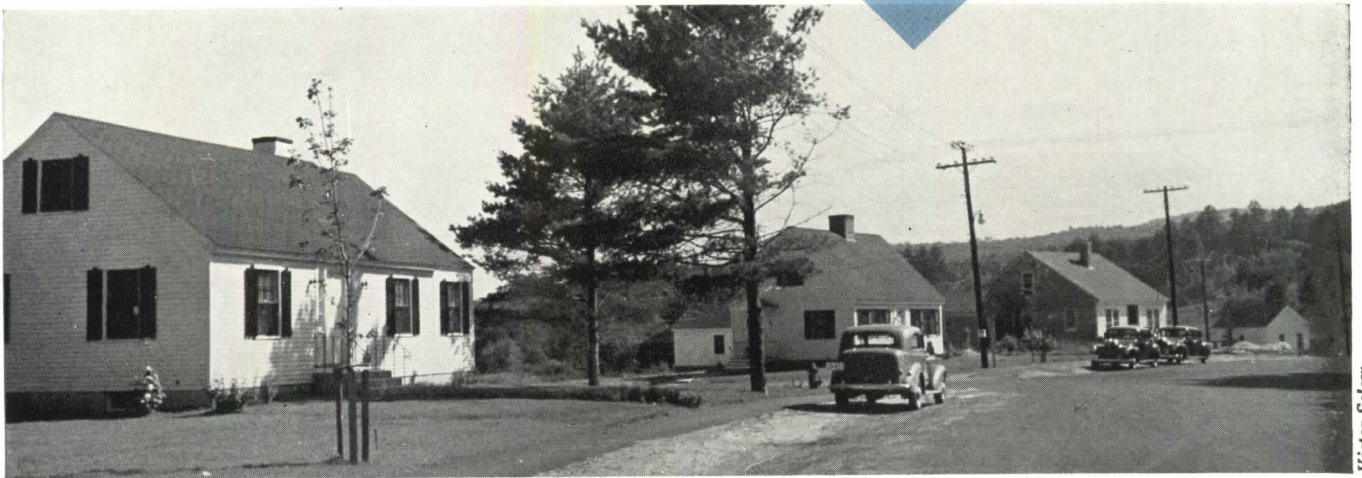

Victor Solow

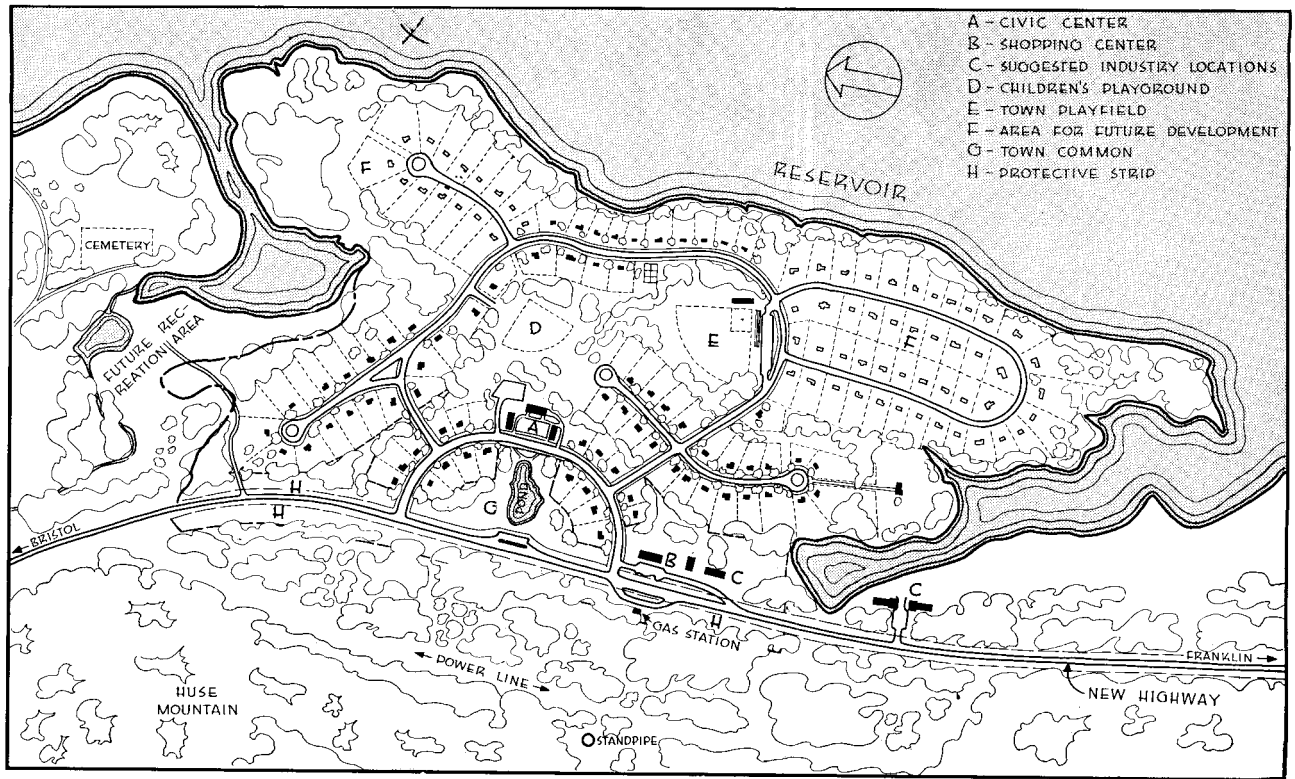

4. DEVELOPMENT OF THE SITE PLAN

- CRITERIA
- ★ Attractiveness and convenience
 - ★ Economy in layout and construction
 - ★ Safety
 - ★ Insurance for the future

THE BASIC PLAN, prepared by the State Planning and Development Commission, was passed upon by the townspeople. Many had no experience with planning or blueprints, and could not visualize the goal as expressed on paper. Hence models and perspectives were prepared, and were explained and re-explained until everyone concerned understood, approved, and participated fully.

In approaching the problem, it was recognized that both family and community life have undergone profound sociological, economic and physical changes in the years of Hill's existence. Without over-emphasis—because to accent them unduly would have been to destroy the naturalness of the project—Hill's design reflects these changes. Streets are safe; small families now live efficiently in modern houses; ample playgrounds provide for open-air recreation.

Attractiveness and convenience. In the new village, a family's living space can extend beyond the home to embrace the whole neighborhood. Satisfaction with Hill's appearance and comfort has increased the townspeople's appreciation of and pride in their community. Approximately half the total area of the village is publicly owned; and this same sense of spaciousness is assured each home owner by providing a half-acre lot for each home, and by excluding from residential areas all forms of commerce. Streets were fitted to contours to afford each home an excellent view. Public paths connect all public areas, and the buildings of the civic center, visible from the new highway, are grouped around an existing natural pond. Large recreational areas, integrated with the village plan, are designed for all age groups, adults as well as children.

Bernice T. Perry

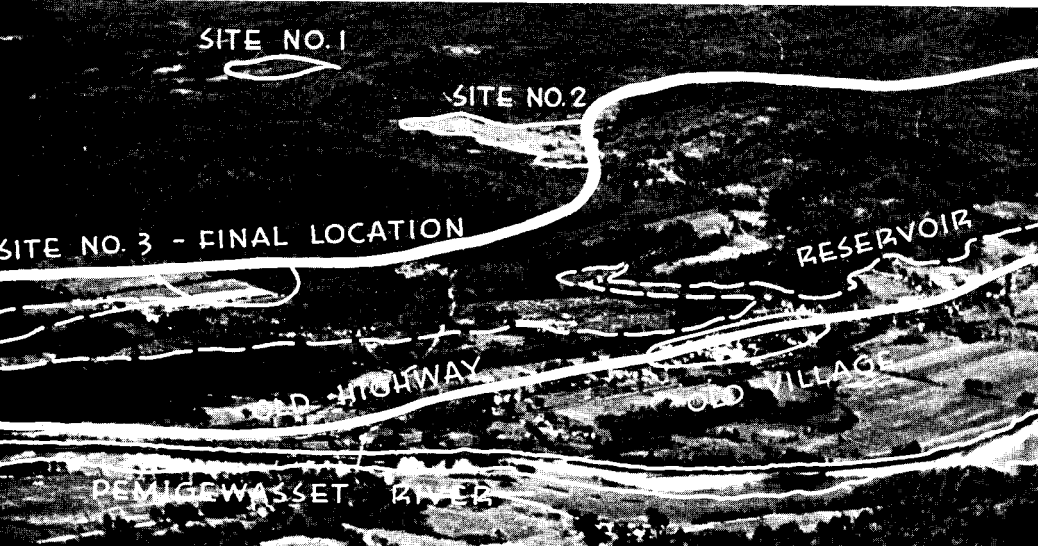

First site was discarded as being too inconvenient a location to develop; second, less distant, was wet, hence needed costly drainage; the third, near old village and new highway, suitable topographically and with good soil, protected from prevailing winds, and possessed of an attractive outlook, was finally selected.

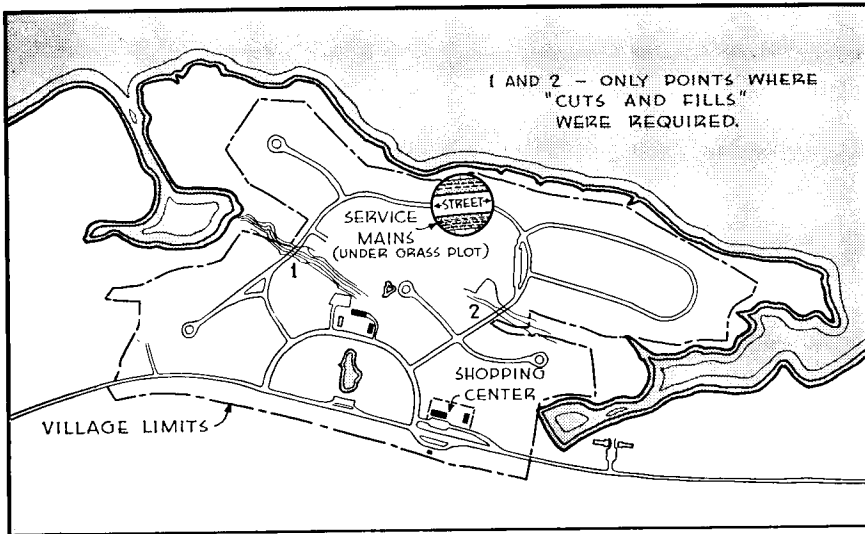

ECONOMY

Limited funds available for rebuilding made economical planning imperative:

Street layout is fitted to topography; only two very minor "cuts-and-fills" were required.

Length of streets was kept to 1¼ mile (compared with 2½ miles abandoned in old Hill) to reduce paving and maintenance costs.

Minimum standard width of all streets (compatible with village needs) was adhered to.

Service mains and conduits are laid under grass strip between sidewalk and pavement—eliminating ripping up pavement for maintenance or additions. *Shopping center* is located to serve both residents and tourists.

Building construction costs were kept low; in public buildings, by combining functions and eliminating unnecessary detail; in private houses by reducing size and utilizing efficient layout, construction and equipment.

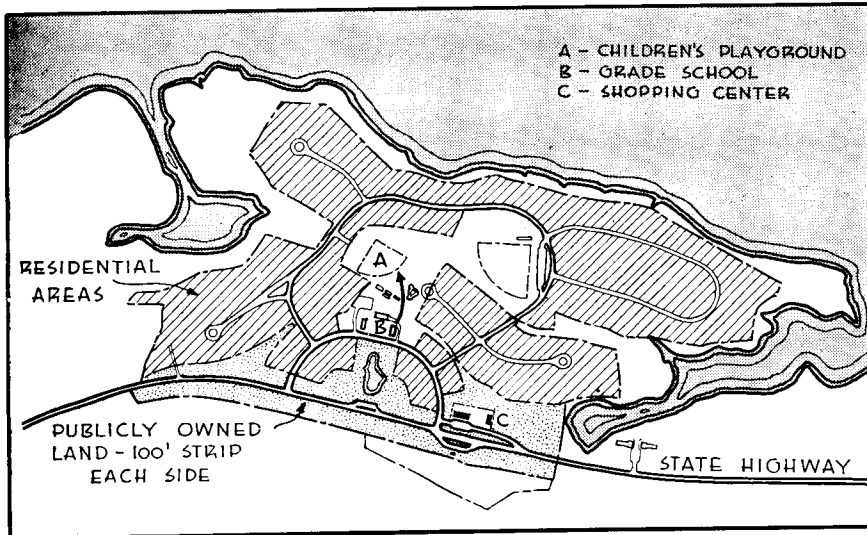

SAFETY

The high speed and density of modern motor traffic, particularly on a route to vacation country, forced special attention to this phase of design:

Location of village at one side of the highway eliminates most reasons for pedestrian crossings, separates local traffic from through traffic.

Building on highway frontage is prevented by public ownership of land on both sides of the highway through village area.

Shopping center layout provides: parking space for tourists; access from the village without interference from through traffic.

Street system (one main street for access from highway to center, secondary streets for interior circulation, cul-de-sacs for residential areas) is planned to make circulation safe.

Children's playground is directly accessible from school; no street need be crossed in going from one to the other.

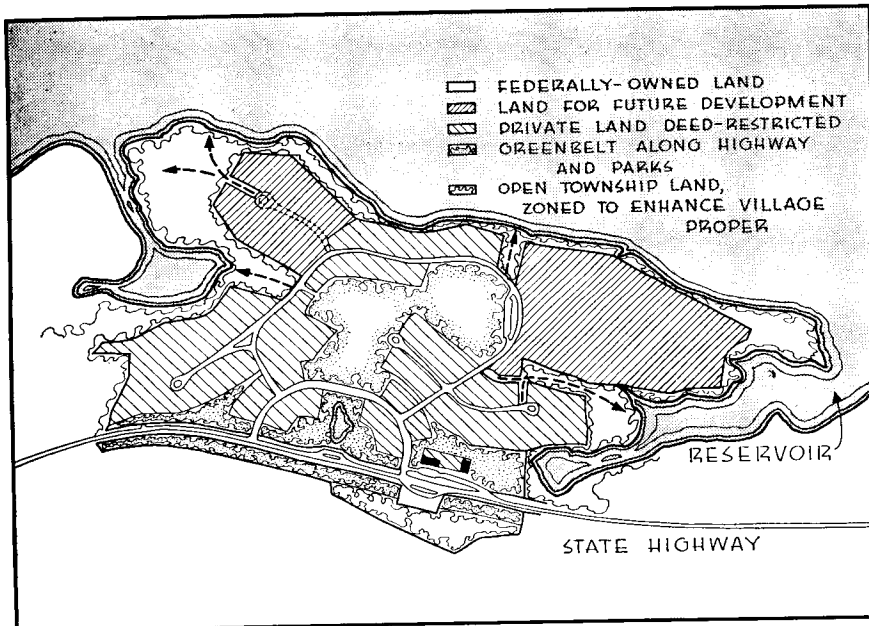

THE FUTURE

To preserve its amenities, to insure its future by controlling its environment, Hill is:

Zoned by design to segregate land use; to provide for increases of residential areas up to twice present size (land owned by or under option to village association); to provide public access to the reservoir area; to insure a continuing harmonious relation between village development and the surrounding township (also zoned);

The owner of public land; greenbelt along both sides of the highway, and open spaces provided in proportion to a planned population expansion;*

Controlled by deed restrictions; houses must be approved in design; must cost at least \$2,000 each; must be set back at least 25 ft. from streets, 20 ft. from side lot lines. Density is less than 1 family per acre. Speculation is prevented: Village Improvement Association will repurchase at original price lots not built on within a year. Water system is designed to serve full development.

*Even before the site was substantially complete, the demand for homes had forced the corporation to open up residential property originally reserved for future use.



Photos Victor Solera

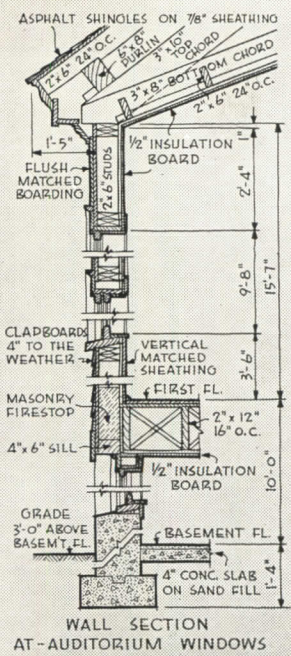

5. COMMUNITY BUILDINGS

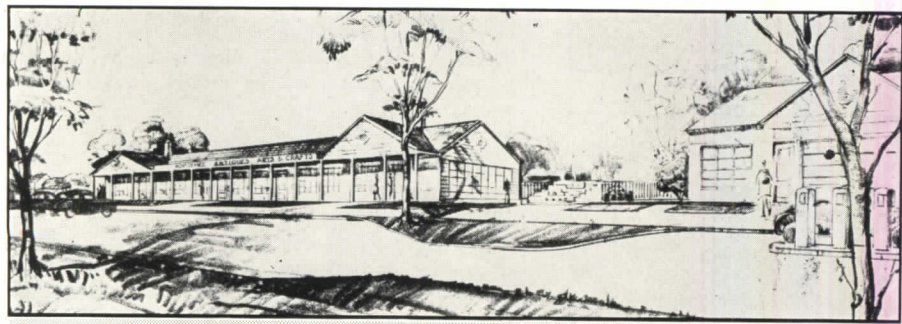

SHOPPING CENTER

SHOPPING CENTER

CHARLES A. BLESSING, Architect, prepared designs in accordance with the master plan, which provides parking space accessible from the town and from Route 3A. The scheme permits buildings to be erected as their need becomes apparent, with the object of unifying them eventually into a harmonious whole. Across the highway from the shopping center there is a gasoline station for southbound traffic (the center's station serves northbound travel) which not only will add to local trade, but may also reduce the need for cars to cross opposing lines of traffic.

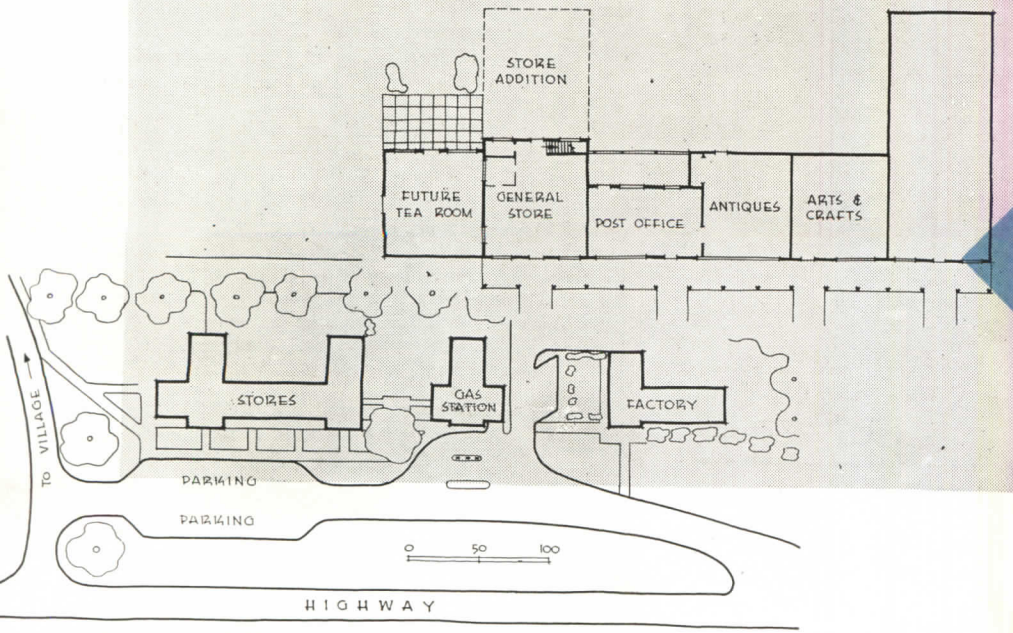



TOWN HALL

WELLS, HUDSON and GRANGER, Architects, faced a most difficult problem in designing a town hall which had to be considerably larger than the old one (above), to contain all the town services and provide a public meeting hall, and yet cost no more than Hill could afford. The first floor houses offices, hall and library; in the basement, town maintenance apparatus and the fire engine share the garage, and there is a kitchen and dining hall. Foundations are concrete; construction is typical wood frame with wooden roof trusses. Interior walls are of unfinished fiber board, with a pine wainscot in the auditorium. Roof is of asphalt shingles. Heat is supplied by a forced hot air system. Total construction cost: \$15,986.85, of which \$1,968.55 was for heating and plumbing; contents, 128,500 cu. ft., at 12.5 c. per cu. ft.

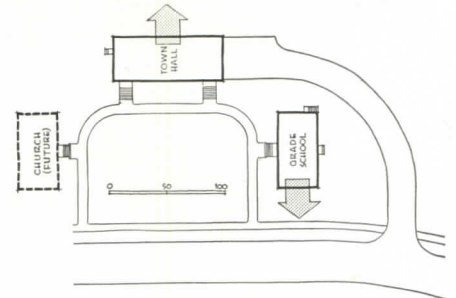
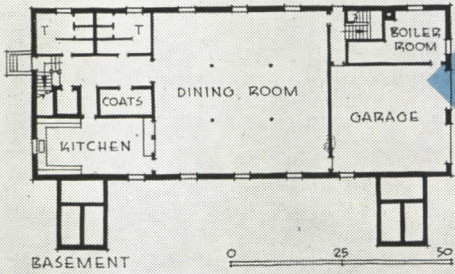
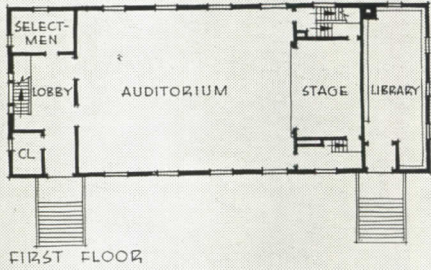

GRADE SCHOOL

WELLS, HUDSON and GRANGER, Architects, here faced the same problem as in the Town Hall: cost. Construction and equipment are therefore similar; exceptions include a wainscot of hard-surfaced fiber board instead of pine, a two-pipe hot air furnace, and the installation of ventilating ducts in classrooms. In addition, the purpose of the building entailed slightly more expensive equipment. Total construction cost: \$9,811.32, of which \$1,479.72 was for heating and plumbing; contents, 62,600 cu. ft., at 15.7 c. per cu. ft.

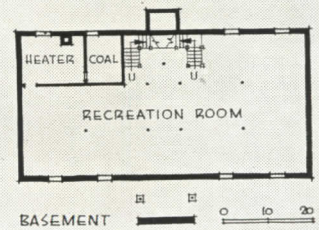
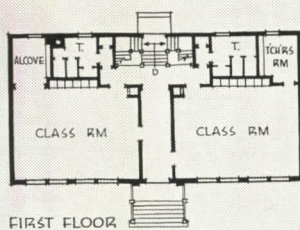



Photos Victor Solow

6. HOUSES



THE TOWNSPEOPLE recognized the importance of coordinating the village plan as a whole, and community buildings and facilities as units. However, to prevent a degree of standardization of private houses which would curtail individual freedom and create monotony, each family was permitted to build the kind of home it wanted—within the loose framework of deed restrictions. If collective planning had been carried one step farther, to include greater architectural control, more harmonious, perhaps more economical, results might have been achieved without undue restraint. Yet, considering local traditions and the scheme's democratic organization, the approach taken is understandable.

The new houses are well built and well suited to modern family sizes and habits. Only a few cost as little as the \$2,000 minimum; four or five were moved bodily from the old village. Most are new, well equipped, with landscaping well started. Their average cost is slightly over \$4,000.

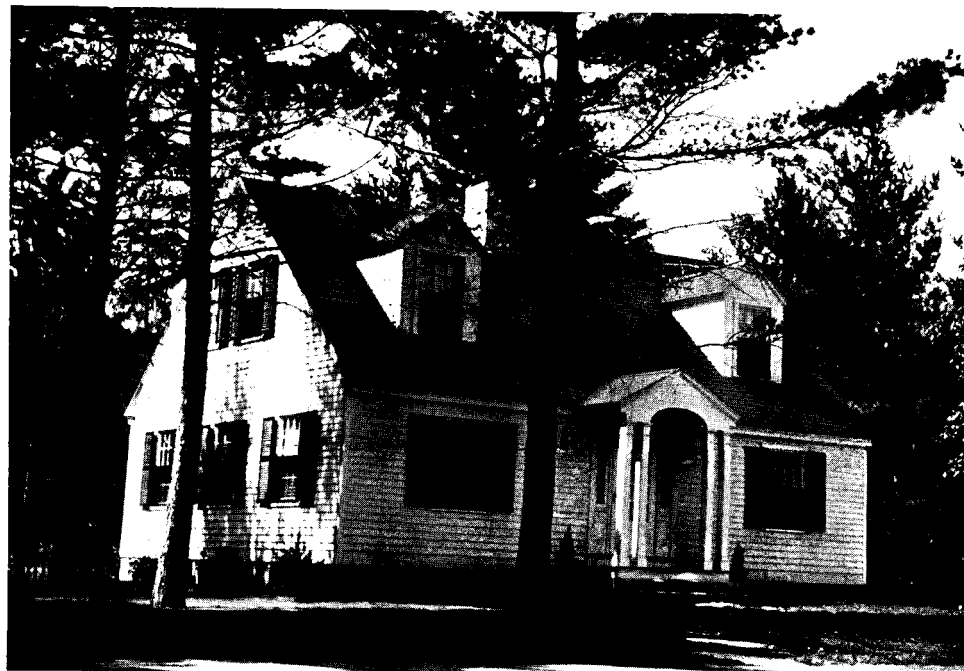

At right, AMSDEN HOUSE; WELLS, HUDSON and GRANGER, Architects



Above, a residential street in the new village; at left, similar view in the old



ROUNDS HOUSE. Taken from stock plans, this house cost \$4,200



CHARLES HOUSE; GEORGE MITCHELL, Architect. This home cost \$6,000 including landscaping; the interior, paneled in pine from a demolished home, was finished by the owner, an upholsterer

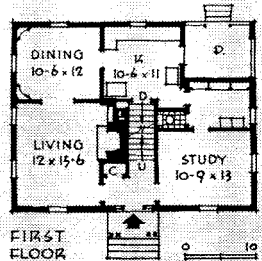
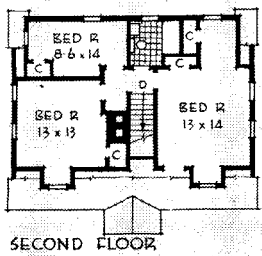

DEFENSE HOUSING

Are we building → → →



For generations we have extolled the Yankee quality of getting our money's worth; our theme song is "use every penny to its best advantage." And we have a grand opportunity, right now, to use this program; use our technical knowledge and planning ability to make the most of the huge expenditures now going into defense housing.

By DOROTHY ROSENMAN

Bringing into focus the social, economic and technical viewpoints, Dorothy (Mrs. Samuel I.) Rosenman here suggests a rational approach to the problem of future blight that is feared in the rush to build defense housing. As head of the National Committee on the Housing Emergency she has become a most vigorous advocate of better, broader planning. While completely realistic about the technicalities involved in the defense housing program, she shows the necessity, and the method, for the integration of new low-cost housing into the existing community.

Our forebears insisted on wise spending in the planning and building of their towns. They thought of their communities as places in which to live, and recognized the fact that development of homes, shops and public buildings ought to be in relation to the use that citizens would make of them. Streets and open areas were planned to fit the living conditions of the day. The very term "commons" reveals that those founding fathers regarded a town as an assemblage of human beings who, though claiming the right to live their separate lives in private, had many needs in common as members of an organized group. They planned their towns to preserve this economic and social pattern.

But with the coming of industrialization, the simple community pattern became obscured by the hasty pressure of home building without thought for present or future use. The seeds of urban blight were sown lavishly and grew quickly; today our communities are reaping the harvest



FUTURE SLUMS → → →

or

of financial burdens and social ills. The cry for urban redevelopment has been raised but the pattern of indiscriminate building continues. It is urgent that we use our ingenuity to untangle the wider problems of home building and community planning.

It is particularly urgent at this moment. Millions of dollars are being spent for housing, for building defense homes. Men, women and children have been pouring into defense areas for over a year. They continue to come in as more defense industries are created and present ones are enlarged. The Defense Housing Coordinator estimated last year that 300,000 homes were needed for workers in defense industries. In 1940-41 Congress appropriated a total of \$420 million for the construction of defense homes and \$150 million for public service facilities where there are not sufficient local funds to meet the extraordinary need. Private enterprise built thousands of homes costing millions of dollars in these same communities.

The Defense Housing Coordinator estimates that in 1941-42 there must be 525,000 more defense homes built. He believes that private enterprise will be able to construct 400,000. He has asked Congress to appropriate another \$300 million to build approximately another 125,000 homes.

Here is an opportunity to get our money's worth, to build the houses so that these huge expenditures will represent a permanent gain



PLANNED COMMUNITIES

to the communities in which they are placed. Here is an opportunity to put to practical use the technical knowledge which has been gathering in the last decade.

Few communities were prepared to meet the emergency. Most of them had no machinery set up. They have been dazed by the piling into their midst of factories, munition plants, shipyards, encampments. They have been completely unprepared to receive the thousands of

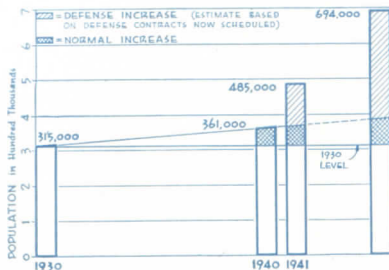

How URGENT is the need to alleviate congestion and confusion in defense areas, and to safeguard a community's future, is seen in a glimpse of the situation in the Hampton Roads area, taken from a report of the Virginia State Planning Boards and the Hampton Roads Regional Defense Council, now jointly tackling the problems of regional planning for both present and future. Nineteen separate defense establishments descended on an area having 12 political subdivisions within a radius of 20 miles. They will eventually bring 400,000 additional people into a community of 350,000, a community which had suffered for 20 years from the last war, and which had really adequate housing for only 150,000. The population is expected to go above 700,000 (chart above). Defense housing projects were started in profusion and confusion—three dozen are shown on the map. The bar below the map gives some idea of the deficiency yet to be met.

workers who have streamed into town. Citizens have cried out against more housing, fearful of what might befall present real estate investments when the tide of emergency employment subsides and the defense plants curtail work.

Without a plan such fear has foundation. Homes indiscriminately dropped upon a community are a hazard. But a plan can readily be had. And that is the need of the moment. With a sensible plan, a community can benefit greatly from the new homes being built for defense workers; without a plan it may be saddled with a great slum problem.

The obligation is a dual one, resting both on the community and on the agencies that sponsor the building programs. The community must do its part to see that shoddy homes that will soon deteriorate into slums are not built, that defense housing is built of material right for the climate, and that its architecture is suitable to the locality. The community must see that the sites selected are adaptable to present and future use within the community. It is imperative that there be adequate public facilities—water supply, sewage

disposal systems, schools, and recreational facilities. Most important, the community should determine its own needs for permanent and temporary housing.

No office in Washington can determine these factors without the aid and advice of the people within the affected community. Unfortunately Washington has attempted it. The results have been varied. Sometimes the resulting project emerged well integrated into the community. Sometimes it emerged as a horror spot.

The blame can be well distributed. Very few communities were prepared to do their share; and some agencies, new in the field and reluctant to accept mature advice, plowed ahead without inquiring whether the community had a plan or was prepared to make one. Some of these errors may have been unavoidable at the launching of so vast a program; but there is no longer this excuse.

Housing needs must be measured by the locality. Many cities and towns know exactly how many outworn homes they have within their boundaries. Those that do not can obtain this information from census

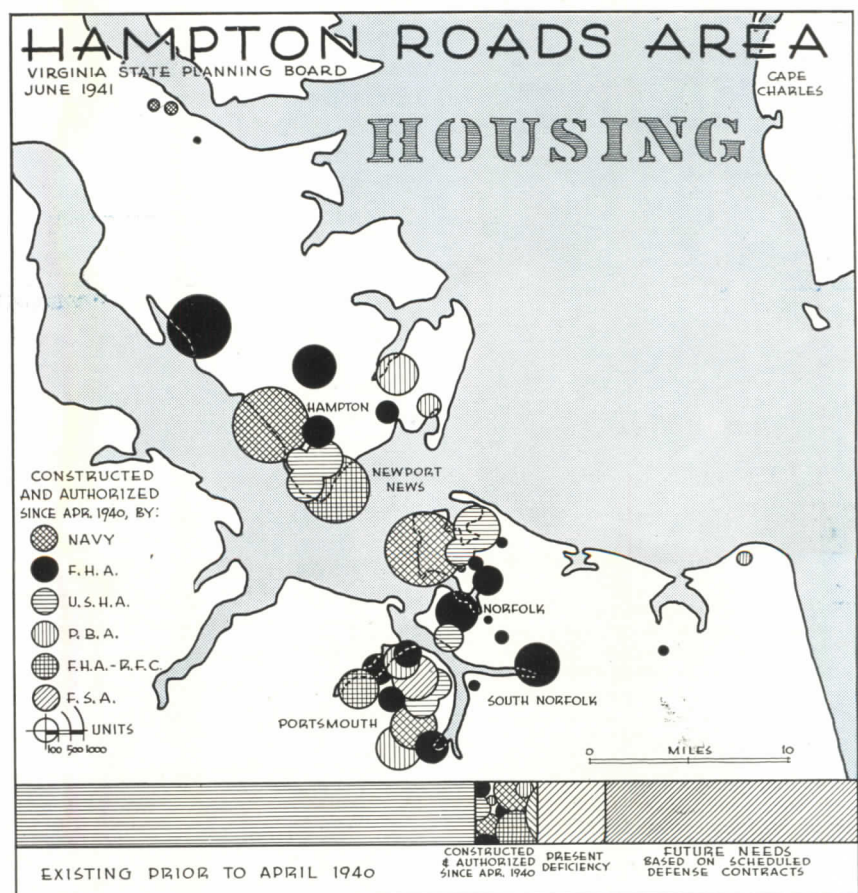

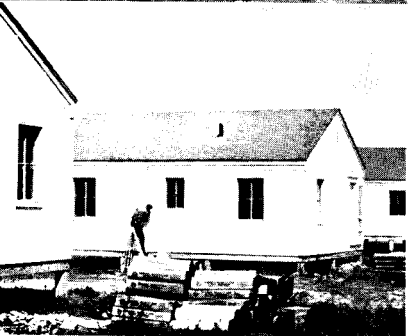
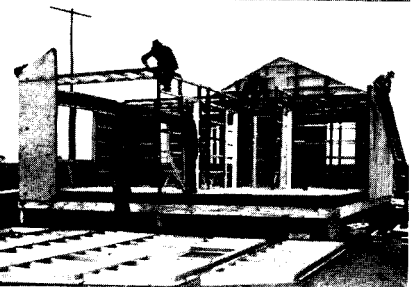
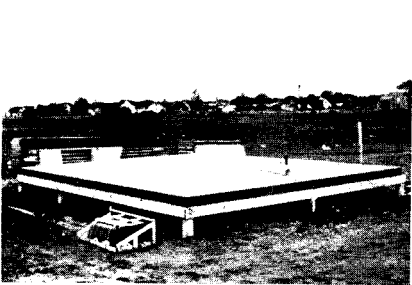
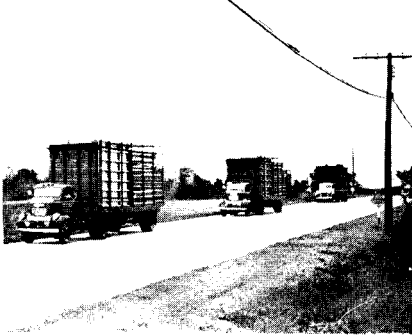
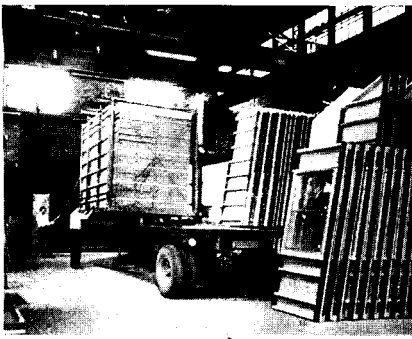

PREFABRICATED, demountable houses may save a small Wisconsin city from the housing aftermath of the last war. Manitowoc built submarines then, and is doing the same thing now, again importing hundreds of workmen from eastern shipyards. Last time, hurriedly built houses remained for years to plague the city and hamper its development. This time demountable houses, trucked from the Harnischfeger plant in Milwaukee, can be trucked out when the emergency is past and the extra workers leave

figures. Wherever defense homes are being built there should be an appraisal of the replacement needs of the community.

Permanent defense homes should be built wherever the normal requirements have not been met. Temporary homes should be countenanced only where the number of defense homes required exceeds the number of unsound homes in the community.

The need is so great that for the moment the planning board cannot insist on equivalent elimination of old housing, as in slum clearance and demolition programs of the past. In this case equivalent elimination cannot be immediately applied because all homes, good and bad, must be used in defense areas at the present time. And when it is applied, after the emergency is over, it should be used as a means of eliminating outworn sections of communities and of rebuilding those sections for whatever use they are suitable.

Slum clearance and equivalent elimination are terms that should not be narrowly applied to rehousing. Many slum areas in congested parts, often interspersed in business sections, are adaptable to other uses. Perhaps they should be remade as parking spaces, broad thoroughfares, parks, recreation grounds. Perhaps business should absorb those areas. Perhaps other houses should be built there, along with parks, playgrounds, cul-de-sac streets, through traffic routes and parking spaces.

There is time to plan the scope, method and use of the equivalent demolition program after the emergency is over. But basic plans must be considered and prepared during the emergency period, and the community's planners should be ready to advocate them as soon as the time is ripe. Now they must ask three questions: "What do we have?" "What do we want?" "How are we going to get it?" And they must be prepared to furnish the answers. They must be ready to get their money's worth from the millions being spent.

Shoddy structures will live on to plague us. Speed is the first concern, it is true, in building defense homes. But a well built, properly

placed house is as speedily constructed as one shoddily constructed or badly located. The appropriately located home takes its proper place in the community, is an asset to it.

Some bad examples of unwise spending are found in earlier projects of the Public Buildings Administration. It is true that defense housing must in general be low-cost housing. But that is no reason to be penny wise, pound foolish in design and construction. Peppered throughout the length and breadth of the land are architectural atrocities; because of them, PBA has been dubbed the Public Barracks Administration. Their construction is not only unsightly, but also flimsy. The front door step resembles a hastily nailed soap box. The coal bin is on the front porch. Color schemes are actually offensive. The same architectural design has been used in every section of the country regardless of terrain, regardless of climate, regardless of the wishes of the community. PBA has been the worst offender, but now it says it has erred, that it will build no more houses without consulting local site planners and local architects. PBA says it would be wiser to construct more solidly, and that its future policy will be so directed.

Has PBA saved time by flimsy construction? I doubt it. Many of its projects are far behind construction schedules. Has it saved money? Even though the initial cost may be low, any saving will be wiped out, and a tremendous loss sustained, by the cost of maintaining and replacing those buildings.

These are grave mistakes. There are many smaller errors. On the West Coast a delightful, appropriate site was selected for a defense housing project. Homes now rest on an elevation which overlooks the bay. But they were planned in Washington and the site planner never visited the site. Consequently the living room faces on a prosaic street and the family must go to the kitchen to view the delightful vista of the bay.

In Newport News, Va. there are hundreds of charming houses financed by FHA. On the average, sites have been well chosen and used. But drive about on a rainy day and you risk becoming mired in the mud

(continued on page 110)



Photos by Cushing-Cellatly

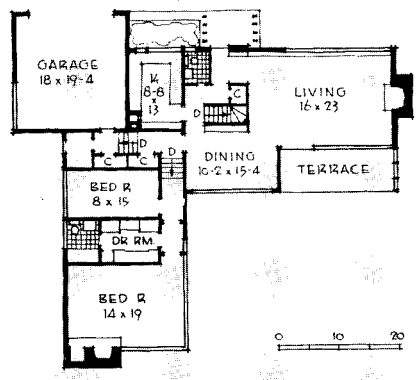

SAMUEL GLASER, Architect

TWO UNIVERSITY OF MAINE PROFESSORS share residence in this house at Orono, Maine. More than a home, the house is frequently used for informal student get-togethers or more serious group discussions. To handle these diverse needs, the plan includes ample and flexible-use areas both inside and outside the house. The living room opens out onto a paved terrace overlooking a river. In the combined bedroom-study, segregated from the rest of the house, one of the professors can hold a student meeting without interfering with activity elsewhere. A ping-pong room in the basement offers a welcome off-the-campus retreat.

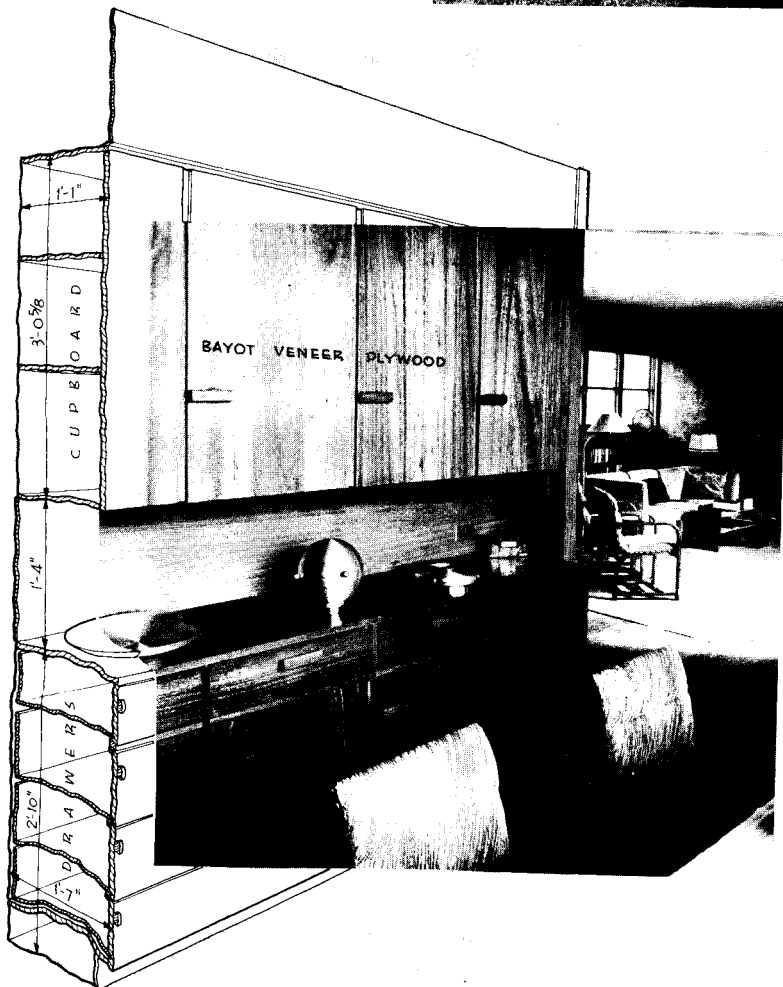
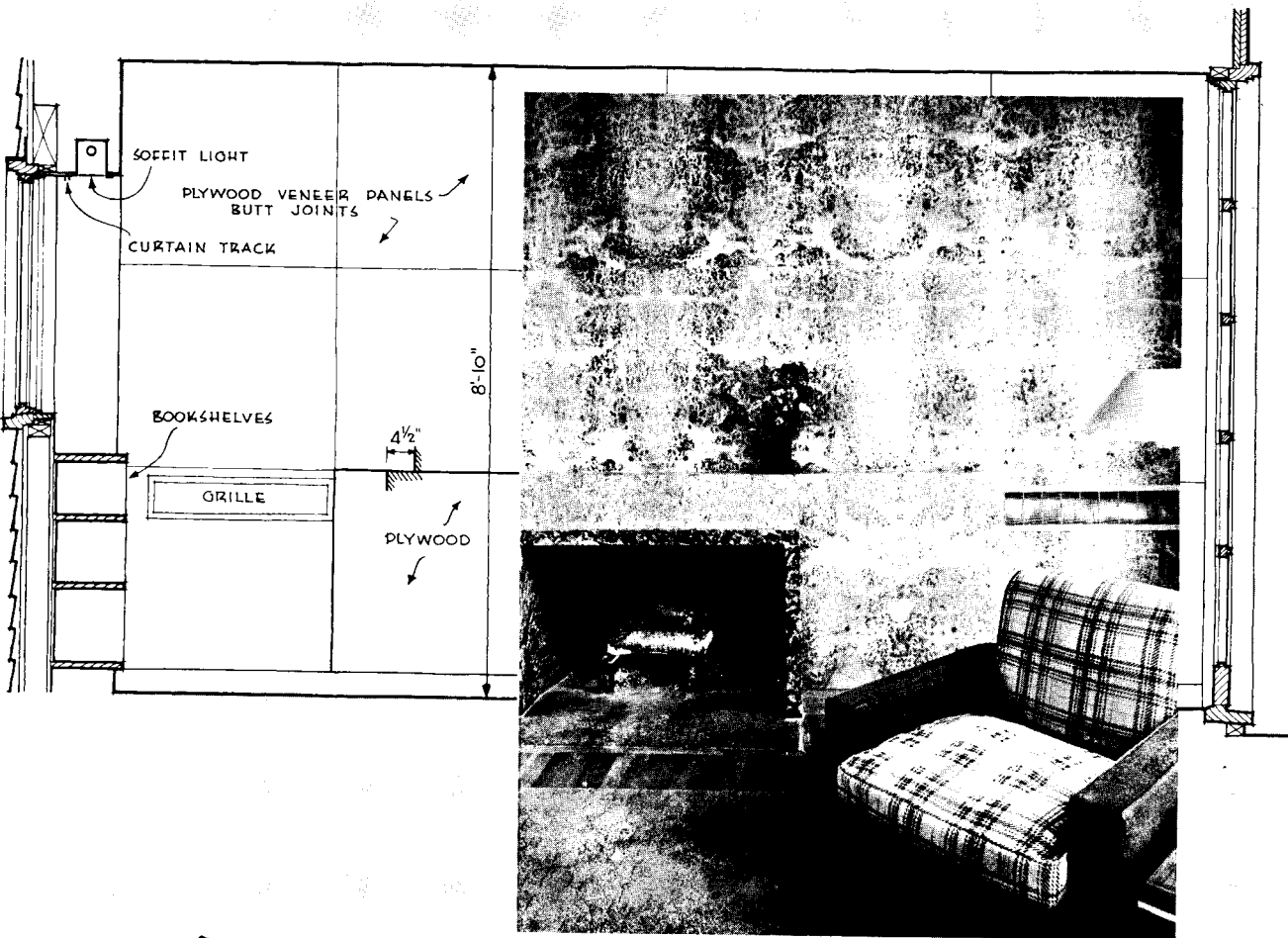

Above, section through living room, showing high windows on the entrance side of the house, full-length glazing toward the terrace and view (see photos above, facing page). At left, detail of the built-in cabinets along one wall of dining room

STRUCTURALLY the house is entirely of frame, with roof joists strapped top and bottom to allow for ventilation. Reflective insulation is used in both walls and roof. The house is heated with a circulating hot water system. Interior walls and partitions finished in plywood—Carpathian burl veneer on living-room fireplace wall; bayot elsewhere.

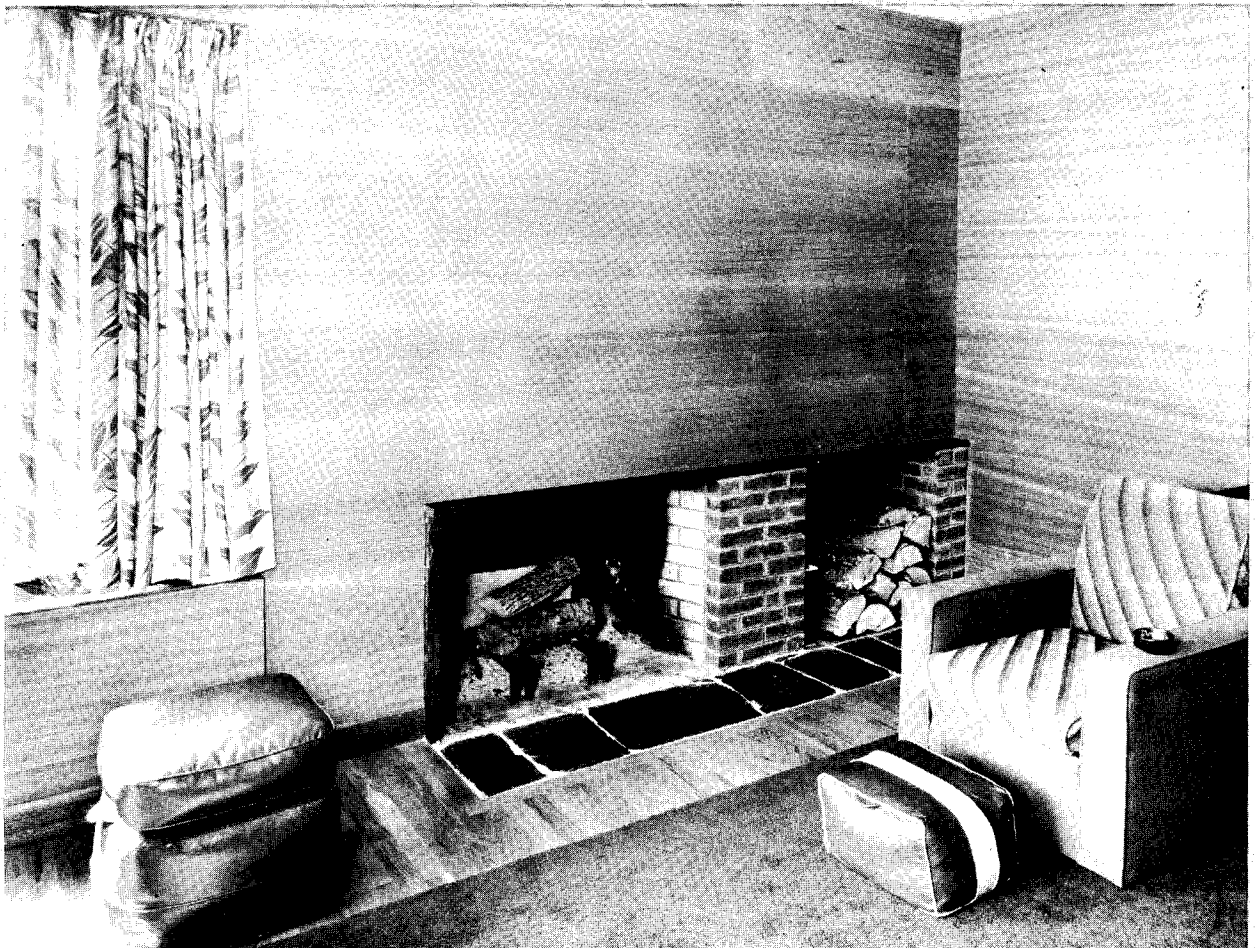

FIREPLACE CORNER of the combined bedroom and study

Photos by Cushing-Gelliaty



Photos by Ernst Kassowitz, Richard Garrison

SMITH, CARROLL & JOHANSON, Architects

DESIGNED FOR BOTH PRESENT BASIC NEEDS and for future expansion, this is the Seattle home of Architect Johanson. The elevation at the center of the sloping lot afforded a sweeping view of lake and mountains. Hence, location of the main floor level at this point, which allowed incorporation of an above-grade lower floor. Eventual plans call for addition of three bedrooms at the rear of the house; a temporary wall that encloses the present bedroom will be removed to form a sizable dining area; and finally, the kitchen and dining space will be moved downstairs, the present kitchen becoming a den. The house is of frame, finished with cedar boards.



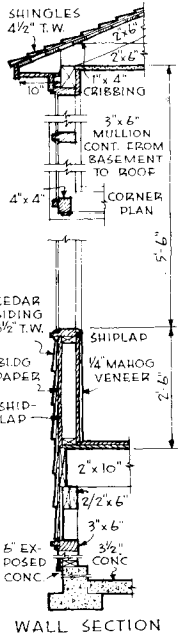

LIVING ROOM. Window mullions are both structure and finish

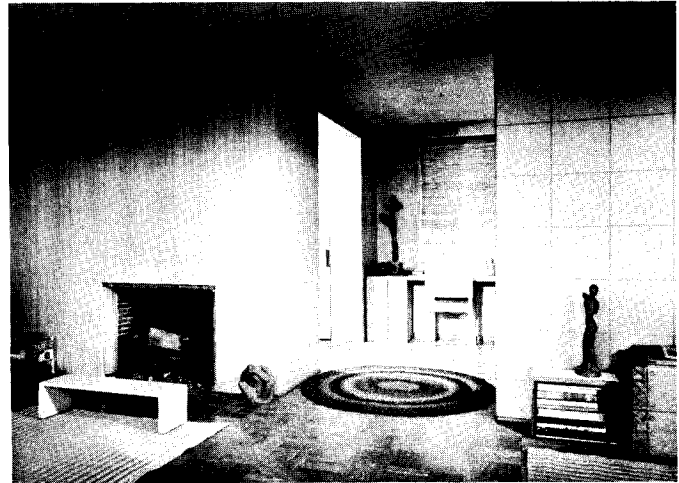
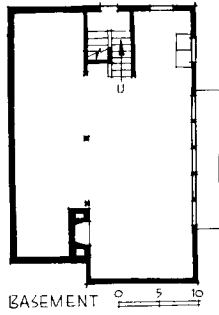
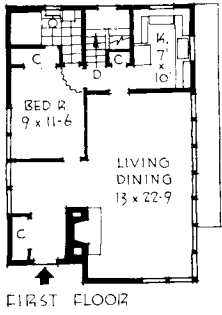

ENTRANCE AREA. Temporary bedroom wall at right



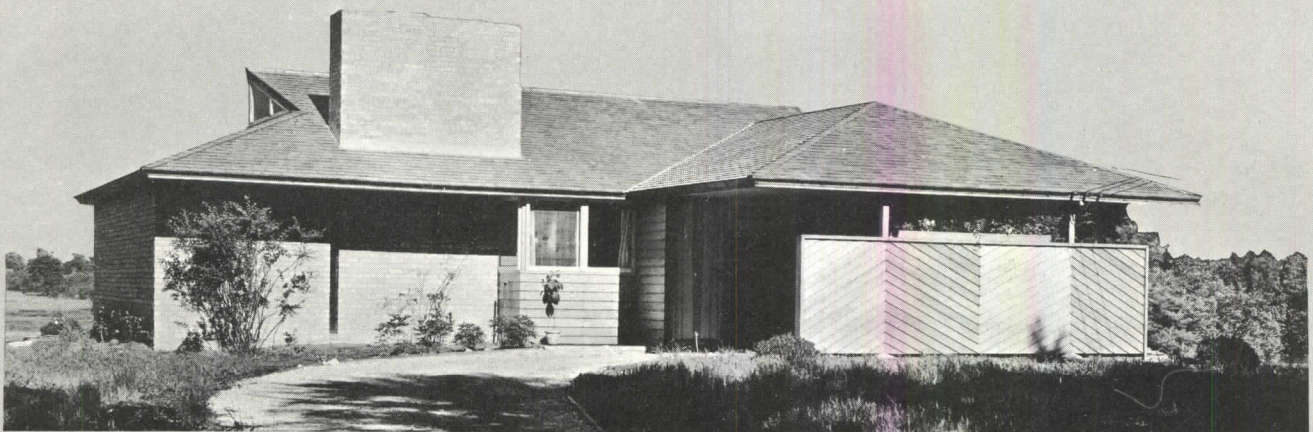

Photos by Hedrich-Blessing Studio

DRIVEWAY ENTRANCE

SCHWEIKHER AND LAMB, Architects

BUILT FOR A CHICAGO SCHOOL TEACHER AND HIS ARTIST WIFE, THIS NOTEWORTHY SMALL HOUSE IS SITUATED IN OPEN, SLIGHTLY ROLLING COUNTRY AT GLEN ELLYN, ILL. The large bedroom serves also as the artist's studio, with one wall providing an uninterrupted band of north light. The teacher's study adjoins. Both of these rooms are ventilated through louvered and screened vents placed below fixed-glazed areas and controlled by down-swinging insulated panels behind the louvres (see detail). The living room is entirely open to the west, the garden, and most desirable view. An economical and functional element of design is the open drive-through carport at the east end of the house which eliminates awkward backing of cars and, in conjunction with the wide roof overhang, provides sheltered passage to both front and kitchen doors. Exterior of the house is finished in California redwood and common brick. The roof is of cedar shingles. Materials priorities note: The projecting roof made it possible to eliminate downspouts and gutters. Except where the brick is left exposed, interiors are surfaced with Douglas fir plywood, rubbed down with a pigmented white lead. All floors are of oak.

Serving counter connects kitchen with dining area. Section shows storage space provided for both

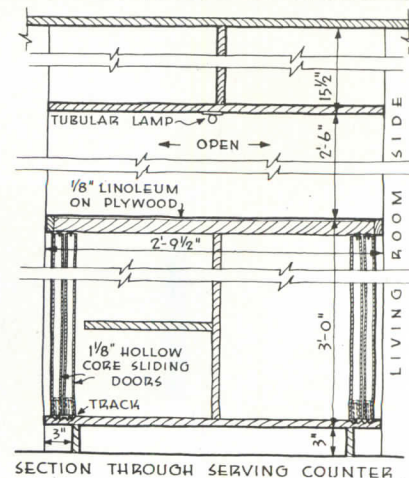

SECTION THROUGH SERVING COUNTER

SMALL HOUSES

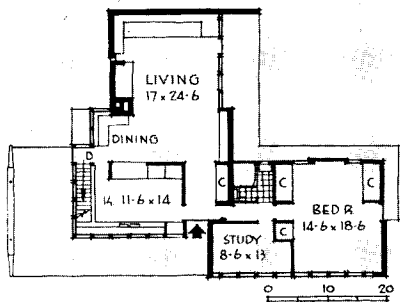
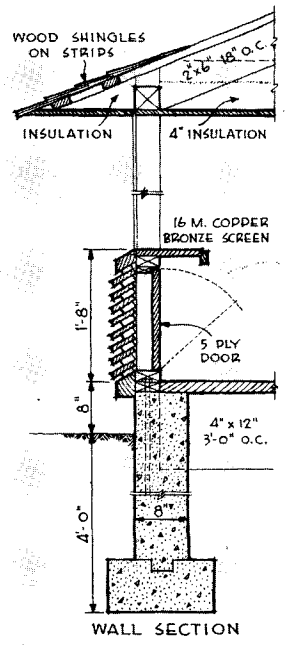

Above, a view of the bedroom-studio (note lowered panel which opens to louvered wall ventilator). Below, kitchen, with continuous built-in plywood cabinets. Counter tops are linoleum





Photos by Rudolph Edward Leppert, Jr.

OSCAR deBOGDAN, Architect

IN THIS NEW HOUSE AT TUCKAHOE, N. Y., modern construction, facilities and equipment are combined with elements — doors, fire-place brick, paneling, etc. — that were salvaged from an old house at Cape Ann, Mass. The replanned house includes a ground floor study with adjacent lavatory which is easily convertible into a guest bedroom. A covered porch on the garden side forms a protected walk to the garage. Above the garage is an unfinished room, reached by outside stairs, which may later become maid's quarters or extra bedroom. The house is painted barn red; oyster-white trim.

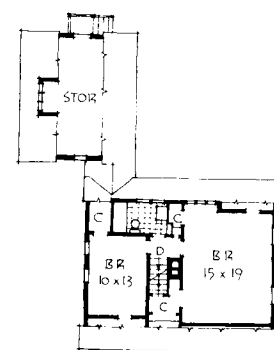

SECOND FLOOR

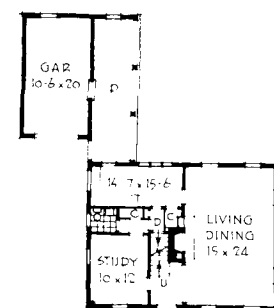

FIRST FLOOR





GREGORY AIN, Designer

GEORGE AGRON, Associate

THIS LOS ANGELES HILLSIDE HOUSE, in distinction to the house on the opposite page, was designed without any predetermined stylistic treatment. The steep site, client needs and climatic factors governed its planning. The downstairs floor of the house consists of a complete bedroom suite with private outside terrace that is segregated from the rest of the house. The splayed walls bordering the upstairs terrace provide privacy for bedroom and service areas. Exterior walls and chimney are surfaced in light buff stucco. Posts, trim and gutters are painted tan. A 12-ft. plate glass window, flanked by a pair of 4-ft. glass doors, makes up the terrace wall of the living room.

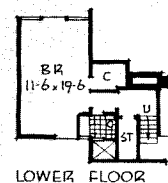
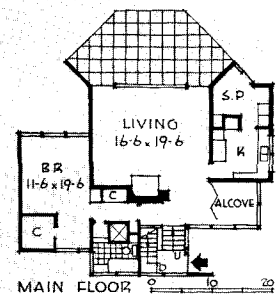
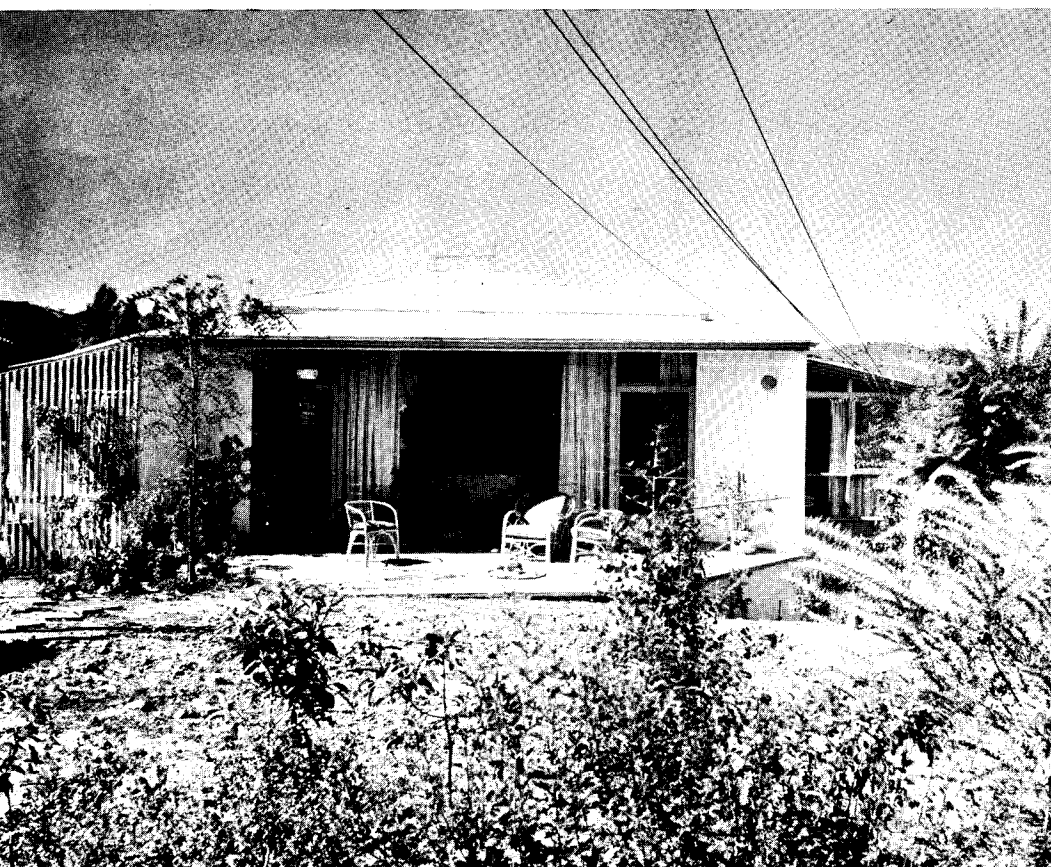

Photos by Julius Shulman

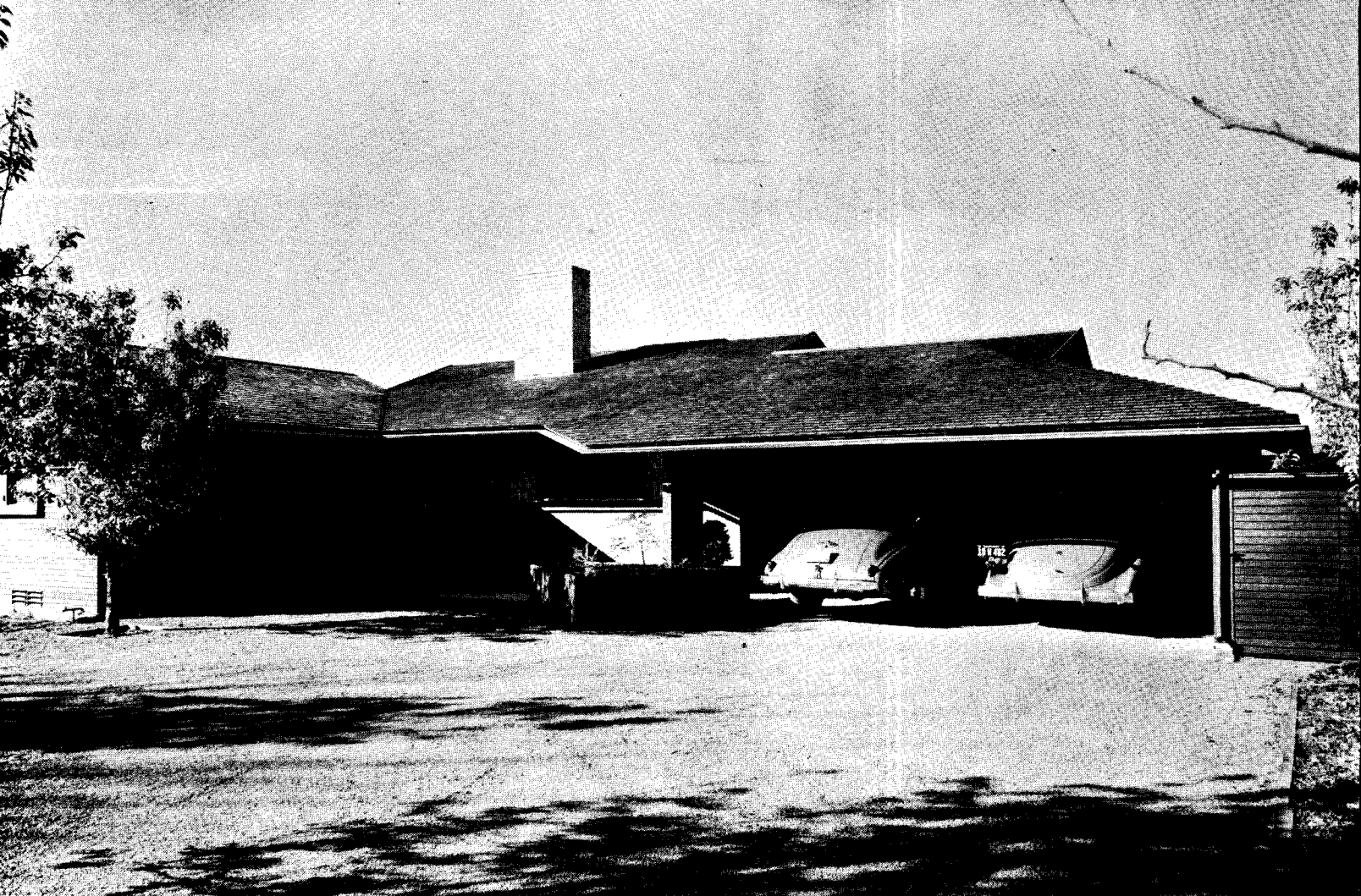

Photos by Esther Born

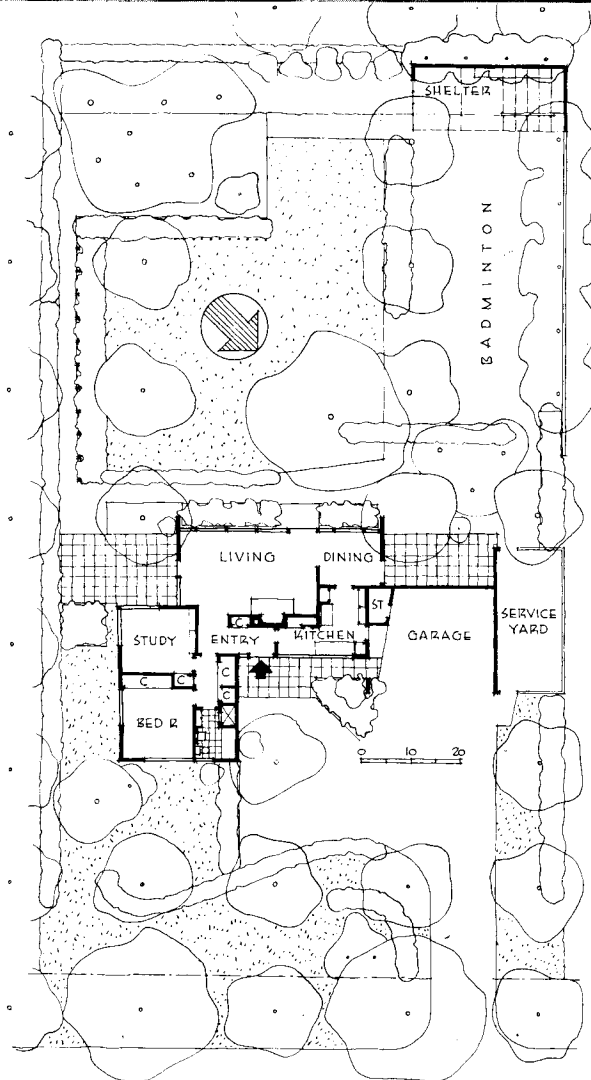

FREDERICK L. LANGHORST, Architect

THE BASIC DESIGN PROBLEM in this house at Menlo Park, Calif. was to provide as much openness as possible in the general living areas; complete privacy for the kitchen, bedroom, study and bath. The study serves both as the professor-owner's den and as a guest bedroom. Interior living spaces are visually expanded to outdoors by continuing wall and ceiling planes out beyond the wall line. Flush redwood boards are used both inside and out. Other exterior walls are of narrow, beveled redwood siding. Serious consideration was given to control of sunlight, as indicated in the sectional drawing opposite. The study and bedroom receive morning sun; the two terraces offer both sunny and shaded outdoor living space all day. Prominent placement of the auto turn and garage is recognition of the fact that arrival by car is customary. From the garage itself, both front and kitchen doors are reached under cover. Landscaping of the lot, which was part of an old orchard, was handled as an important and integral part of the whole design. Credit for this goes to Landscape Architect Garret Eckbo.

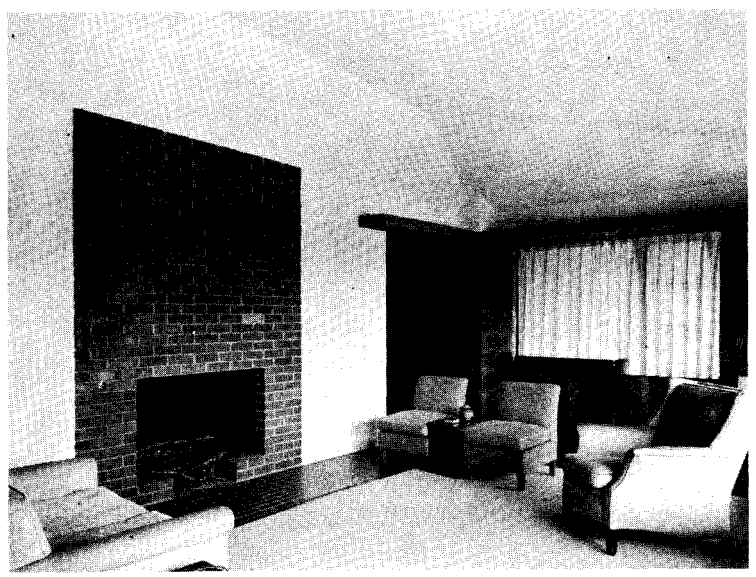
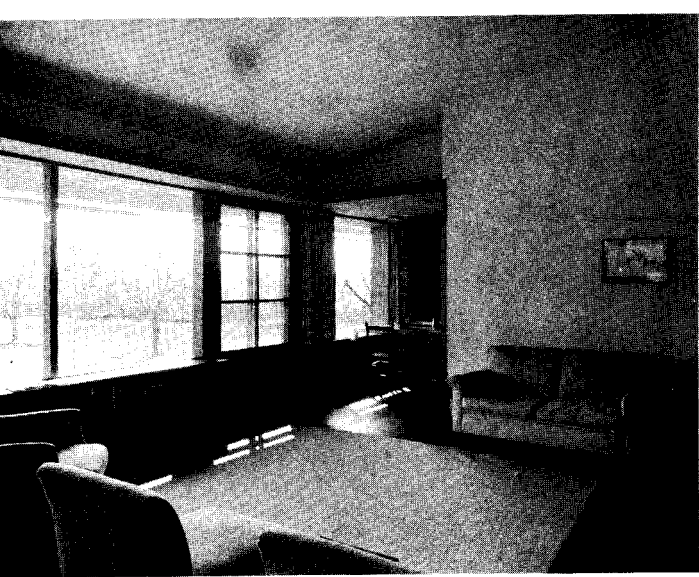
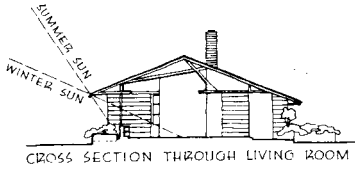
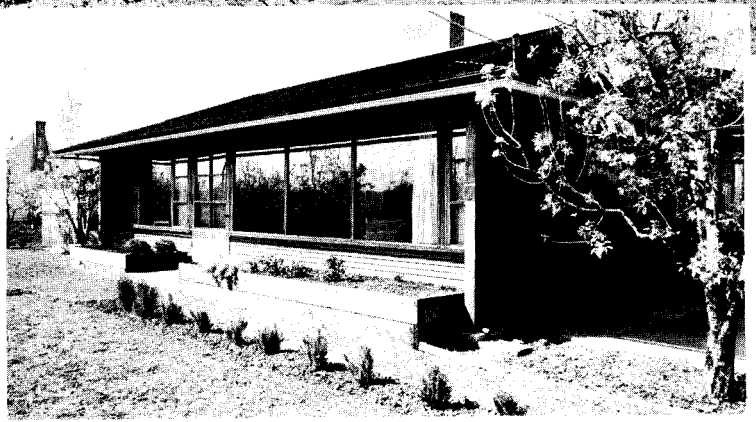
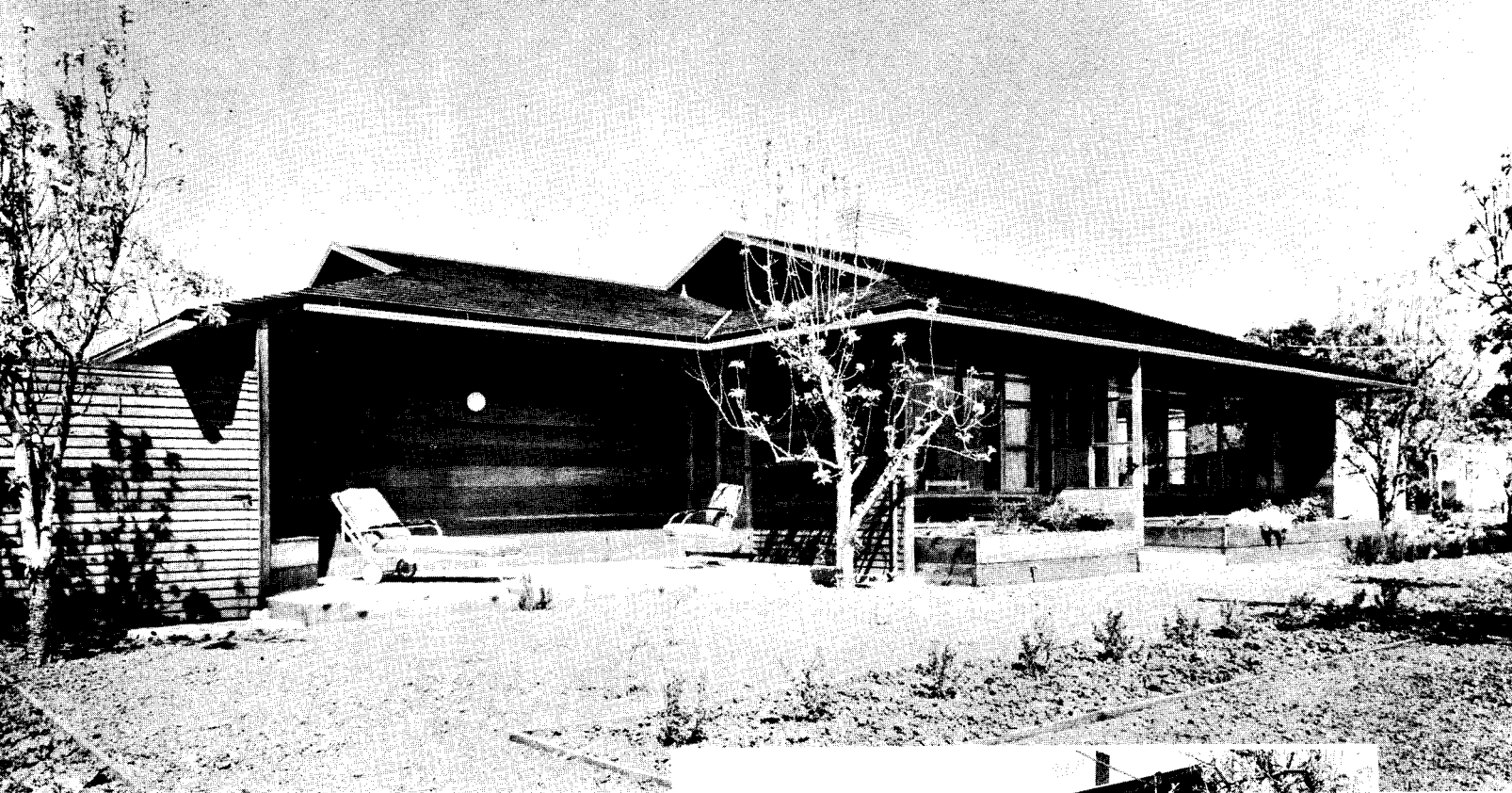



Photos by Orville K. Blake

FRANCIS PALMS JR., Architect

THIS COMPACT, ONE-STORY HOUSE AT BETHESDA, MD., is organized around the central living room and planned to capitalize the pleasant woodland outlook at the rear. Careful planning of the generous storage closet off the kitchen also produced a small entrance hall, a storage cabinet for the dining area and access from kitchen to front door without the necessity of entering the living room. Advantage was taken of the change in grade by placing the heater room and garage at a lower level at the front of the house. Wall construction is of second-hand brick backed up with cinder block. Interior finish is plaster over perforated gypsum board, applied to furring strips. Sash are of steel; exterior trim, cypress. The roof is surfaced with slate.

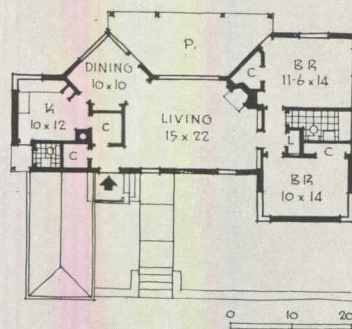

VIEW FROM NORTH



FRONT DOOR (Garage at left)



LIVING ROOM



HOUSING FOR DEFENSE

THE 525,000 UNITS now urgently required for defense housing were not even dreamed of a year ago. Today the need for them is so pressing that plans for almost every other type of residential structure may have to be shelved.

Nearly 300 communities will be affected for years to come by the types of housing now being developed. Design problems in such a program are many and varied. The familiar search for the better, cheaper house is intensified in the defense effort. And progress has recently been rapid, as the examples in the following pages show.

But in some respects the search has shifted, bearing more directly on the peculiar needs of defense housing. Standardization is suddenly less objectionable. Speed of construction has become a dominating factor. Mass production techniques have been given new scope. All of these pose design problems, at the same time breaking down some old barriers to advancement. The great galaxy of alphabetical agencies is devoting heated, almost competitive study to building types. And, while defining basic standards ever more rigidly, they are searching intensively for new ideas, and an increasing number of imaginative architects are working out solutions. After a helter-skelter first year the defense housing program seems to have generated a new appreciation for the designer's skills.

A BUILDING TYPES STUDY

REQUIRED FOR 1942: More architects in both public and private defense housing work; projects better planned for local conditions and community needs; better building types for low-cost defense housing.

PLAN STANDARDS FOR DEFENSE HOUSING

Good practice recommendations stress economy in all construction phases; unit plans offer tested suggestions for local project design.

IF A SINGLE WORD had to be chosen to characterize today's housing needs it would be "Economy." Low cost is, of course, the most obvious implication of that word. OPM has set \$6,000 as a rigid top figure for housing, *with land*, to shelter workers in defense industries; and projects to be constructed under terms of the Lanham Act will be regarded unfavorably if the average total cost of dwelling units is much over \$3,500.

But this defense housing watchword refers also to every phase of

the building operation. Economy of space in planning; economy in the use of materials and units of equipment; economy in the time needed to plan, build and equip projects—all these are factors that bear importantly on the construction of any defense housing project, whatever its size, type or location.

The same observation can be made to some extent in relation to any sort of building project—and particularly to small houses. But the need for unusually expert planning, for speed in

construction and for low overall costs and high utility coupled with the lowest possible operating and maintenance expense can scarcely be overestimated in any discussion of defense housing.

For this problem is different. It is not necessarily "minimum" or "industrial" housing—though really small houses for factory workers are involved in many projects. It has essentially nothing to do with "slum clearance"—though new neighborhoods well developed now may justify fortuitous slum clearance operations when the need for defense has passed. Nor can it be regarded primarily as speculative land development—though private enterprise is importantly involved and in all defense areas houses are being built for both the sales and rental markets.

Defense housing touches these three fields and is variously involved in many of their wide potentials. But it stands by itself as a unique and special technical problem which, for successful solution, calls for every bit of understanding, experienced skill and able ingenuity that architects, engineers and builders can muster.

This is further emphasized by the fact that requirements for defense housing may vary widely in the more than 275 areas where such housing is currently needed. Differences in climate, and topography, in costs and availability of labor and materials and even in local living customs make it virtually impossible to determine any one technical formula which will fit all cases with equal facility.

For this reason the housing experts—those connected with such Federal bureaus as USHA, FHA and FSA and architects in private practice who have made a special study of the subject—are unanimous in emphasizing that their recommendations are offered primarily as suggestions reflecting standards of good housing practice. Thus, the following notes—briefed from codes and comments

| Dwelling Type | Property Density {Dwelling Units per acre} | Net Density |
|----------------------------------|---|-------------|
| Detached houses, 1 and 2 stories | 4 - 9 | 6 - 12 |
| Twin houses, 1 story | 5 - 12 | 7 - 14 |
| Twin houses, 2 stories | 6 - 13 | 8 - 16 |
| Row houses, 1 story | 8 - 16 | 10 - 20 |
| Row houses, 2 stories | 12 - 21 | 14 - 28 |
| Flats, 2 stories | 16 - 32 | 20 - 40 |
| Quadruplex, 2 stories | 18 - 24 | 24 - 32 |
| Apartments, 3 stories | 25 - 45 | 30 - 60 |

Densities for defense housing projects as recommended by USHA. Net density refers to property area minus spaces reserved for playgrounds, etc. For distribution of dwelling units USHA recommends: one bedroom, from 0 to 15%; two bedrooms, from 60 to 75%; three bedrooms, a minimum of 25%.

| No. of Bedrooms | Range of Net Areas from Minimum to Suggested Maximum in Square Feet | | | | Additional Bedrooms for 2-person occupancy |
|-----------------|---|---------|---|---------------------|--|
| | Living Room a | Kitchen | Aggregate area of Living Room and Kitchen | Principal Bedroom b | |
| 1 | 160-180 | 50-100 | 210-250 | 120-130 | |
| 2 | 160-200 | 50-110 | 240-280 c | 120-130 | 100-110 |
| 3 | 160-210 | 70-120 | 270-290 c | 120-130 | 100-110 |
| 4 | 160-220 | 80-130 | 280-300 | 120-130 | 100-110 |
| 5 | 160-220 | 110-140 | 300-330 d | 120-135 e | 100-115 |
| 6 | 170-220 | 110-150 | 310-340 d | 120-135 e | 100-115 |

a. If heating unit is to be in living room, increase sq. ft. of floor area correspondingly; except that, where heating season is short, minimum living room area may be used.

b. Principal bedroom should be arranged to accommodate infant's crib in addition to other required furniture.

c. In some cases, generally in 2-story row houses, aggregate area may need to be increased.

d. Design units of 5 and 6 bedrooms with special attention to dining arrangements in either living room or kitchen.

e. Maximum recommended areas have been increased so bedrooms may be designed for some day-time use.

Room sizes as recommended by USHA. One-person occupancy bedrooms may be provided with areas of 65 to 80 sq. ft. but with the smaller dimension not less than 7 ft. Use of larger bedrooms, however, increases the flexibility of dwelling units with respect to family composition and size and tends to reduce the per-person cost of housing. Minimum size for a bathroom is 32 sq. ft., and a minimum of 30 sq. ft. for general storage should be provided for a family.

originating with technicians of USHA and FHA*—and the sketch plans that accompany them embody principles which experience has shown will assure generally adequate housing. Each of them, however, may be subject to revision in detail according to the particular situation encountered on a specific housing problem.

Planning: Tables on page 72 report the limits of land densities and room sizes that USHA has determined as adequate. They are guides to problem solutions, but are subject to qualification.

Relative to land use, topography is vastly important—as are such factors as soil conditions and the character of ground cover. Site planning—that includes not only building locations but roads, play spaces, orientation, etc.—cannot be standardized. But often it determines the success or failure of a housing project.

*USHA has recently issued a mimeographed compilation covering standards for Defense Housing, Lanham Act Projects; and FHA is preparing five outline specifications—two for medium rent projects and three for low-rent projects—to serve the same purpose for privately financed defense housing.

The second point involves not only room sizes but room arrangement and provision of doors and windows as these factors may be influenced by local living customs and variations in family living habits. Adjustments of room size and unit plans may be necessary according to the character of household furniture and equipment, a point that is increasingly important as tenant or owner income lessens and as family size increases.

Study the accompanying plans with particular reference to the following:

1. Basements are relatively expensive, but required in some instances. USHA recommends they be omitted and first-floor general storage space plus utility room substituted.

2. Minimum storage facilities as recommended by USHA are: *general*, 30 sq. ft. per family; and *personal*, about 2 lineal ft. per person in bedroom closets. Closets should be 22 in. to 24 in. deep. A coat closet and linen closet are required for each dwelling unit.

3. Plan dimensions have in most cases been established to permit use of standard sizes of construction

units with minimum waste. Also, in FHA plans a common building depth allows development of continuous buildings and use of various types of housing units. Most FHA plans exceed commonly accepted minimum room dimensions.

4. Room arrangement will be influenced by: (a) type of heating (see USHA plans); (b) stair required for basement or second floor and (c) family size. This last refers primarily to bedrooms which, most authorities agree, should be grouped together. USHA stipulates that the bathroom shall be accessible from all bedrooms and also the living room without passing through another room.

5. Ventilation, says USHA, must be provided in all habitable rooms by windows (or a skylight in the bathroom) that open to 50 per cent of their area and give a direct outside exposure of from 10 to 15 per cent of a room's floor area. Mechanical ventilation is held unacceptable for defense housing projects. And ceiling heights for all living quarters must be at least 7 ft. 10 in. according to USHA rulings.

USHA

NOT TO BE REGARDED as standard plans, these floor plan suggestions were prepared by the Technical Division of the United States Housing Authority to present graphically its basic requirements for low-cost defense housing. They economically embody the standards of room areas, closet and storage spaces, circulation, heating and plumbing. USHA points out that the architect is urged to study other possible solutions, keeping in mind these principles: Basements have been omitted for economy. All units are self-contained. Each has individual heating and hot water, sink and laundry tray, space for washing machine in the kitchen or utility closet adjacent, space for general storage in addition to normal closet allowances. Some plans show a space heater for gas or oil fuel, located in living room. Alternate schemes show a forced warm air heater, for coal, in a separate heater room.

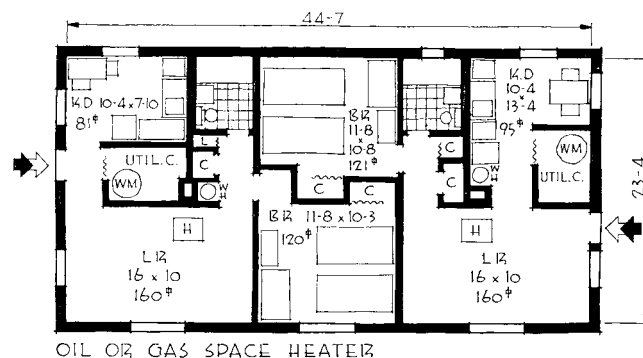

OIL OR GAS SPACE HEATER

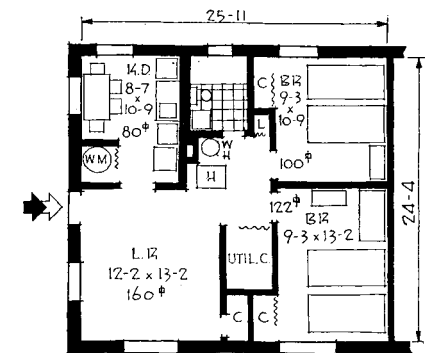

OIL OR GAS SPACE HEATER

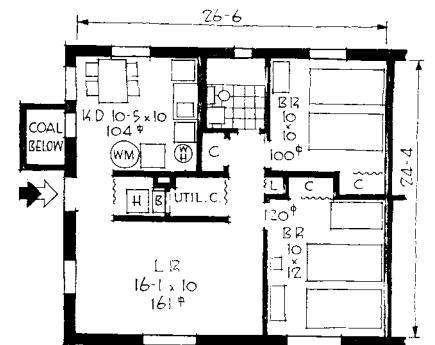

COAL FIRED FORCED WARM AIR SYSTEM

ONE-BEDROOM TWIN HOUSE, with various arrangements of kitchens, utility closets and heating systems

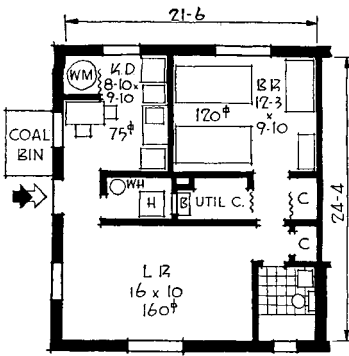

COAL FIRED FORCED WARM AIR SYSTEM

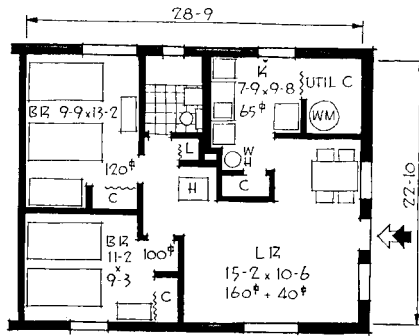

OIL OR GAS SPACE HEATER

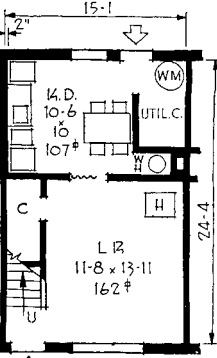
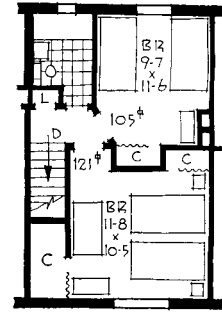

OIL OR GAS SPACE HEATER

TWO-BEDROOM ROW HOUSE, upper and lower floors

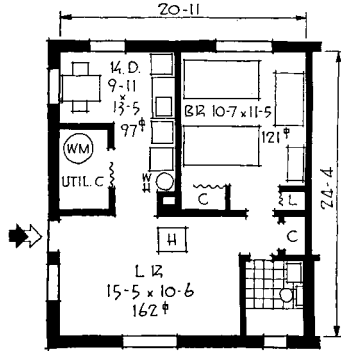

OIL OR GAS SPACE HEATER

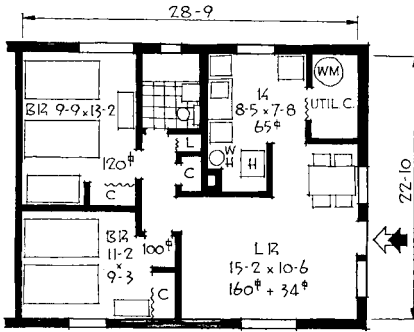

OIL OR GAS FIRED FORCED WARM AIR SYSTEM

TWO-BEDROOM TWIN HOUSE, in four alternate suggestive arrangements

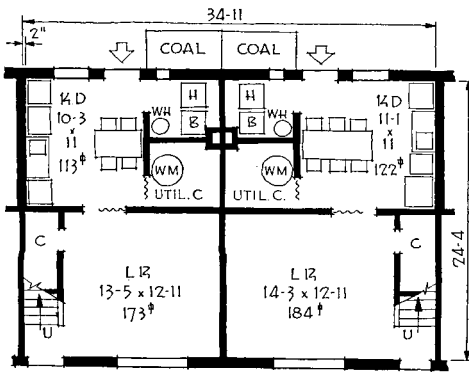
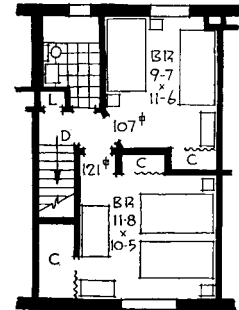
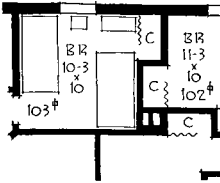
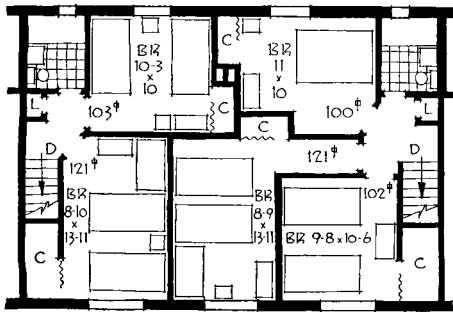

COAL FIRED FORCED WARM AIR SYSTEM

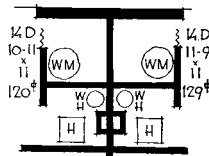

ALTERNATE FOR OIL OR GAS FORCED WARM AIR SYSTEM

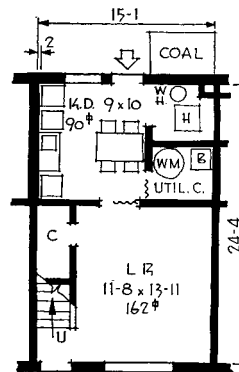

COAL FIRED FORCED WARM AIR SYSTEM

TWO- AND THREE-BEDROOM ROW HOUSE, with alternate utility arrangements for different heating systems

TWO-BEDROOM ROW HOUSE, upper and lower floors

TO EXPEDITE vitally needed housing, the Federal Housing Administration has drawn suggestive floor plans for rental housing, of which selected examples are here shown. With no intention of shutting the door against other plans, FHA makes these available to short-cut processing of unit plans, and to illustrate as quickly as possible various plan requirements. There are two series, prepared by Eugene H. Klaber, Director of Architecture, differentiating between "low-cost" and "medium" rental housing. The schemes are new, and an attempt has been made to conform to priority requirements for defense housing. In general the plans exceed the minimum dimensions that have been prescribed, the principal intent being to illustrate desirable standards. Circulating heating systems are indicated in all plans, for in housing designed to be permanent FHA is not satisfied with the performance of space heaters or floor furnaces. All of the plans indicate a common building depth, though it is not the same for both price classes. The depths are selected to permit use of standard joist lengths without waste, and development of continuous buildings of a common width, with any desired combination of living units. In the plans shown, two units are given in each case, with heating systems indicated in one, except in the medium-price class where heating plants are placed in the basement.

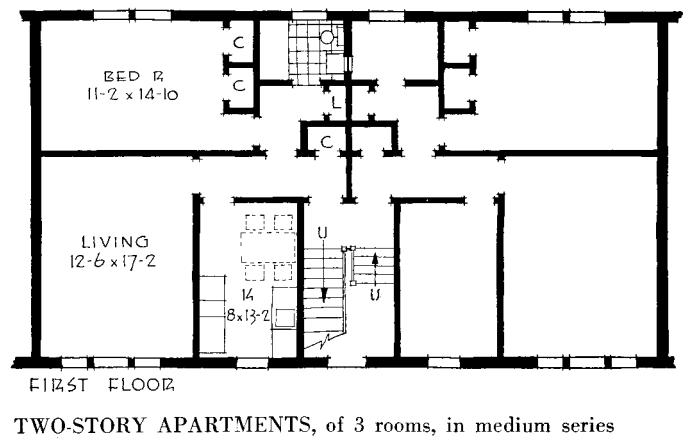
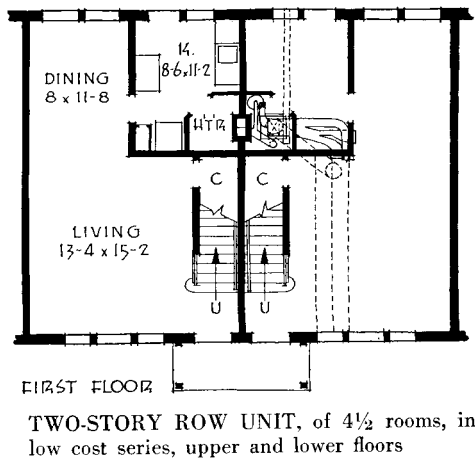
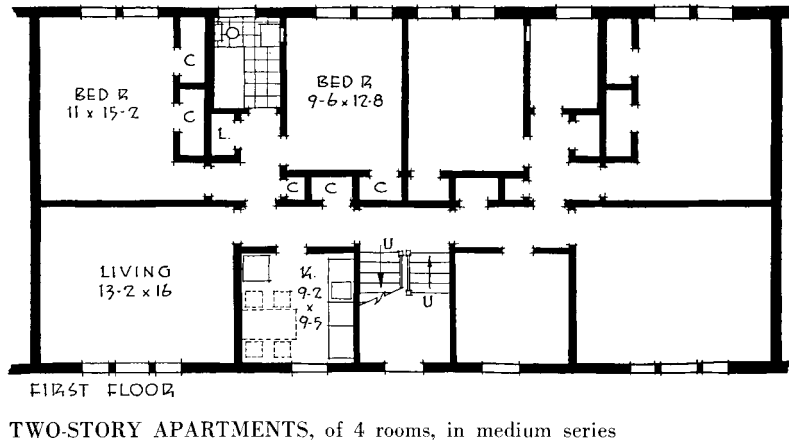
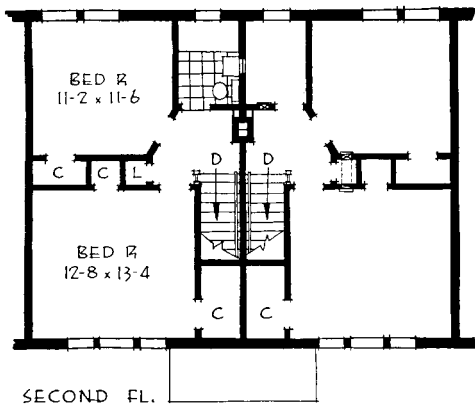
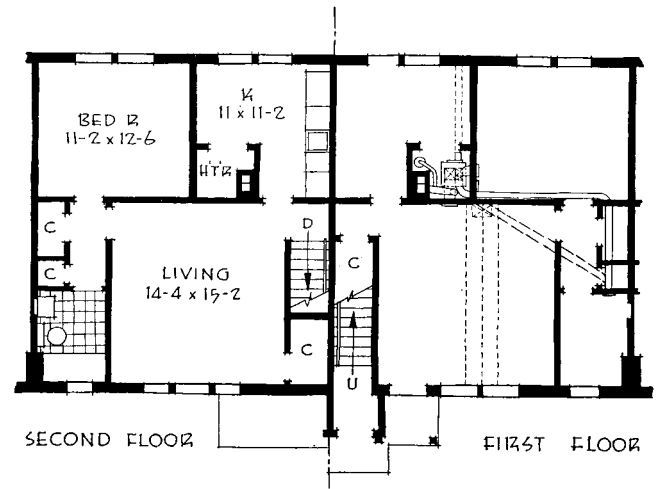
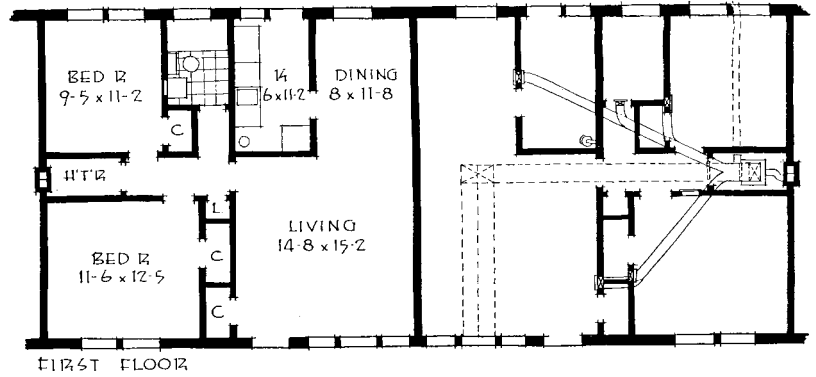

OTHER TYPES

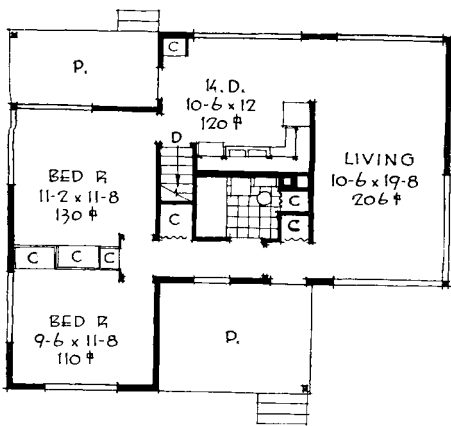

FIRST FLOOR

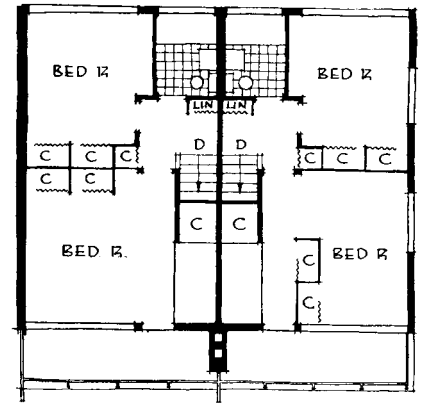

SECOND FLOOR

WHAT the future holds in the way of advancement in the conception and planning of the low-cost house is glimpsed in these plans developed by Architect Antonin Raymond. Noteworthy in the single-family house (left) is the inside bathroom, with monitor above. Another unique feature is prefabricated, demountable closets. They are fastened in place with screws and can be moved about to suit a tenant's needs. Or, as indicated in the

upper floor plans (right), they can be shifted to form a partition, enclosing a third bedroom. Further economy in partitioning is realized by use of curtains and a ceiling track to separate dining and living rooms. While the individual houses are larger than usual, they are being built for \$3,300. The plans are in use for several "experimental" units as part of USHA's Parkridge Homes defense housing project at Bethlehem, Pa.

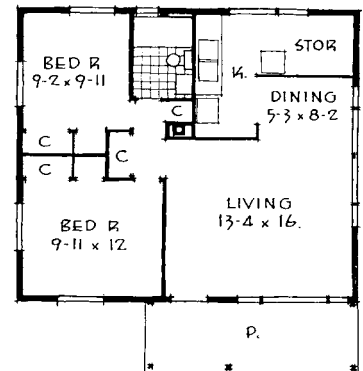
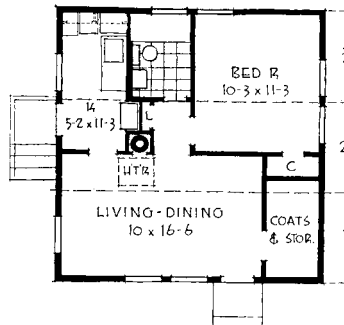
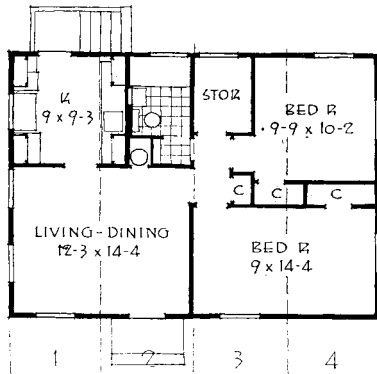

CONTAINING all of the elements considered essential for the single-family defense house, the plan on the left represents a variation from the "universal" overall size of 24 by 28 feet. It was developed by the Tennessee Valley Authority particularly for the sectional construction plan of truckable units, hence the increased width and decreased depth. The four sections, indicated on the plan, are shop prefabricated, trucked to the site and joined. The one-bedroom house at the right is similarly constructed in three sections. Both plans are in use by TVA for housing for workers on dams and in defense industries.

REGARDED by many as most noteworthy of the schemes for the basic 24 by 28 house, this plan developed by John B. Pierce Foundation and Skidmore, Owings & Merrill, consulting architects, is used for hundreds of houses by the Stansbury Corp., Baltimore (AR 5/41).

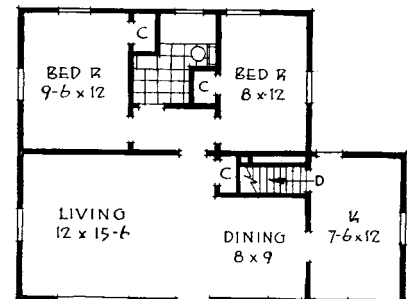
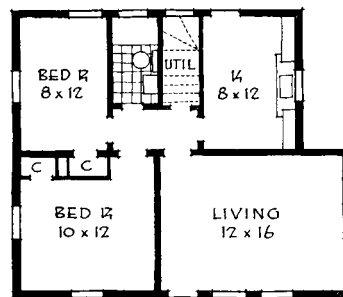
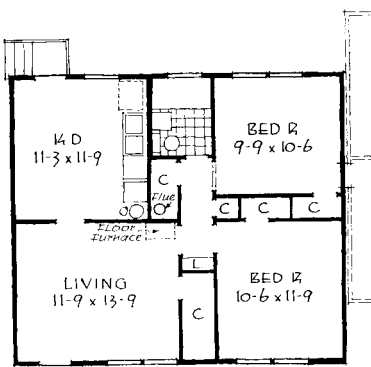

ONE of the many variations of the basic 24 by 28 house, this plan is being used in a huge project of Precision-Built units by the Homasote Company, done for Public Buildings Administration at Vallejo, Cal. It can be used for a single family house, or in rows. When adjoining units are staggered as indicated by dotted lines, a bedroom of one unit can be thrown into the next.

HERE is a slightly abbreviated version of the 24 by 28 plan, this one a standard plan of the Gunnison Housing Corporation, used for their prefabricated construction. A feature of this plan is that it can be used with or without basement. If there is no basement, the space adjacent to the kitchen is enclosed for a utility closet; the same space encloses the stairs to a basement.

AN ALTOGETHER DIFFERENT plan also cuts the basic 24 by 28 dimensions somewhat, this being possible because basement space provides the all-important utility storage room. This is a standard plan used for prefabricated construction by the National Homes Corporation, and currently being shipped in considerable quantity for defense housing in a large privately financed project at Alton, Illinois.

Sketches by Gene Hawley



TRAILER PARKS FOR DEFENSE. FARM SECURITY ADMINISTRATION. Completely mobile and immediately available, the trailer serves a primary need. FSA trailer parks have road, water, sewer and electrical systems. Utility buildings contain toilet, bath and laundry facilities. One trailer costs \$1,000, without service facilities. A "convertible" house (below) offers more for the same cost.



A HOUSING IDEA ON THE TRAILER PLAN



CONVERTIBLE DUPLEX UNITS. FARM SECURITY ADMINISTRATION. The next step up from a trailer, this unit is prefabricated and demountable. It can be moved to another location, or converted after the emergency for single-family use. Panels are rearranged as the numbers indicate; only one to be cut.

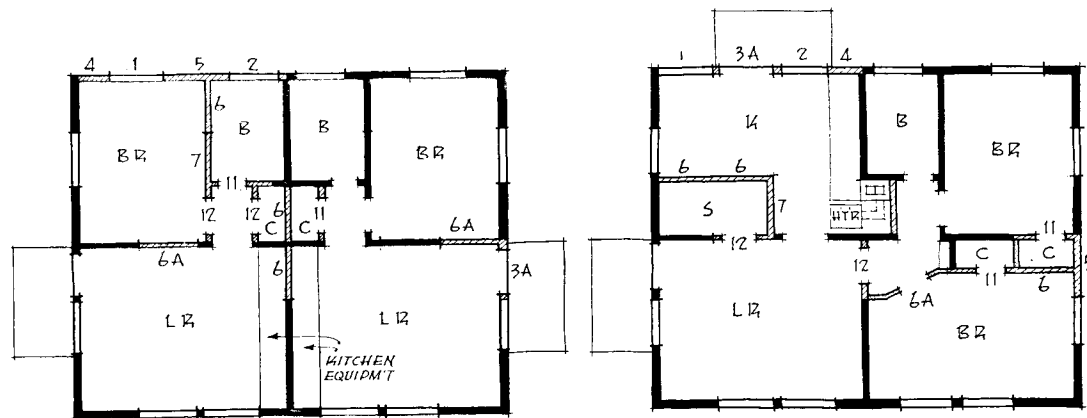

PANELS are moved according to the numbered scheme, and a duplex becomes a single-family house



CONVERTIBLE DUPLEX UNITS. TENNESSEE VALLEY AUTHORITY. Much the same idea is back of TVA's development of the truckable, convertible unit, built in prefabricated sections and completely demountable. It can be used singly or combined in duplexes. Duplexes can be converted for single-family occupancy by just opening a doorway and removing one set of kitchen equipment.

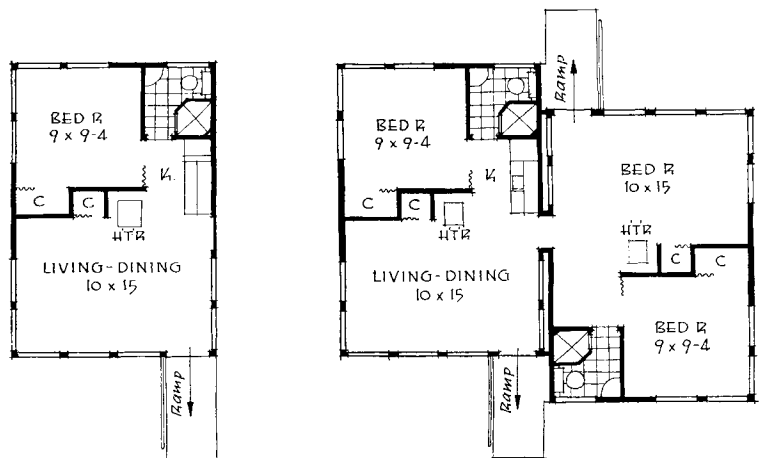



PLANNED FOR ECONOMY WITH

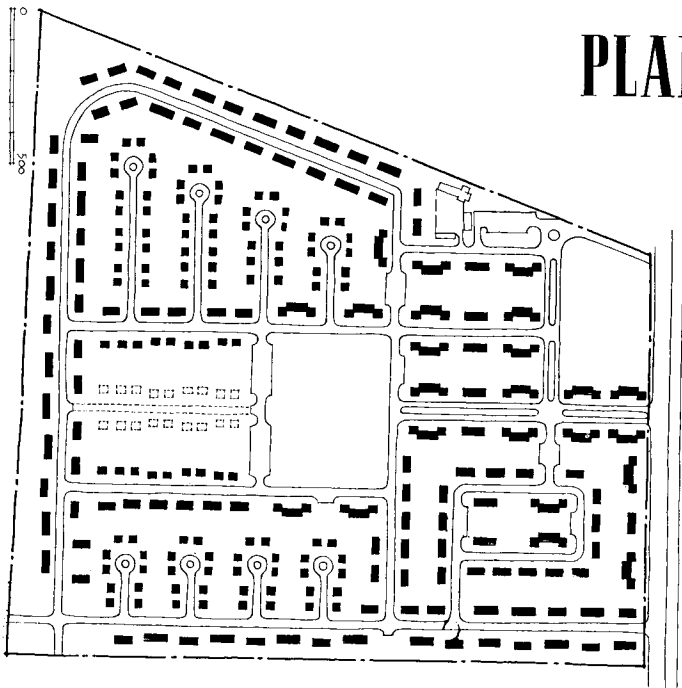

PUULOA HALE DEFENSE HOUSING PROJECT, OAHU, T. H. SUPERVISING ARCHITECT'S OFFICE, PUBLIC BUILDINGS ADMINISTRATION. Economical construction in this 550-unit project permitted full equipment while keeping overall costs low. Walls of one-story houses are of single board thickness. In two-story units first floor walls are 2-by-4 stud construction with 1-by-8 shiplap outside and 1/4-inch veneer board inside, with single-board construction above. Cooking, lighting, refrigeration and water heating are all electrical. Equipment includes refrigerators, sink and laundry trays, water heaters, ranges, and venetian blinds. Charles J. Pietsch, chairman of Hawaii Housing Authority, project managers, reports the cost, including everything from overhead to taxes, as \$3,400 per unit.





FINE EQUIPMENT

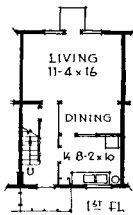
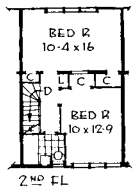
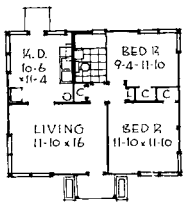

Two basic plans are combined in several ways, sometimes with minor variations, to produce variety in building forms. Typical buildings are one-story single-family houses; one-story two-family houses, which simply combine two like units; and four-family row-type buildings. But occasionally one-story houses are combined with two-story row units, as shown on the opposite page. Widening the row-type plan just a little permits the addition of a third bedroom on the upper floor.



DEFENSE CLAIMS A HOUSING PROJECT

ARSENAL COURTS, ROCK ISLAND, ILLINOIS. CERVIN & STUHR, ARCHITECTS. Late in the planning stage this project, originally conceived as slum clearance, was called to the colors to serve as housing for arsenal workers. The planning change was remarkably simple, involving only the addition of a parking area; a survey of the arsenal workers soon disclosed a higher ratio of automobiles to families than had been originally contemplated. Relief from the monotony of multi-family units was achieved with some two-family units, one- and two-story buildings, all with pitched roofs. These smaller buildings were distributed along the perimeter so as to be the first seen by visitors, or used at the end of vistas. Floor plans conform quite closely to recommendations of the USHA.

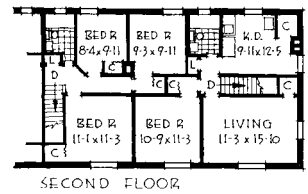
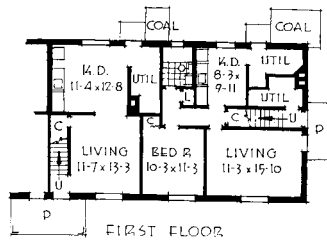
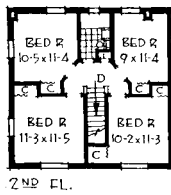
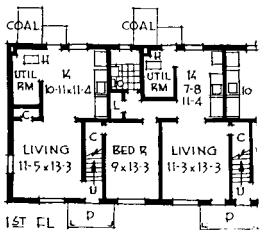
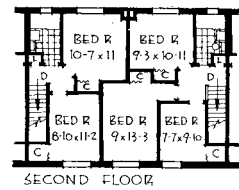
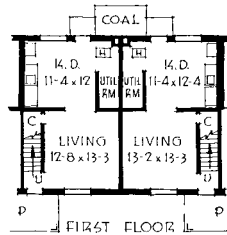
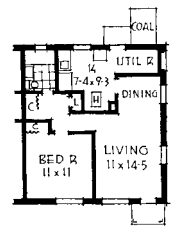

Photos by Lickman

SMALLER STRUCTURES grouped in front of Administration Building form a forecourt leading to center of project.

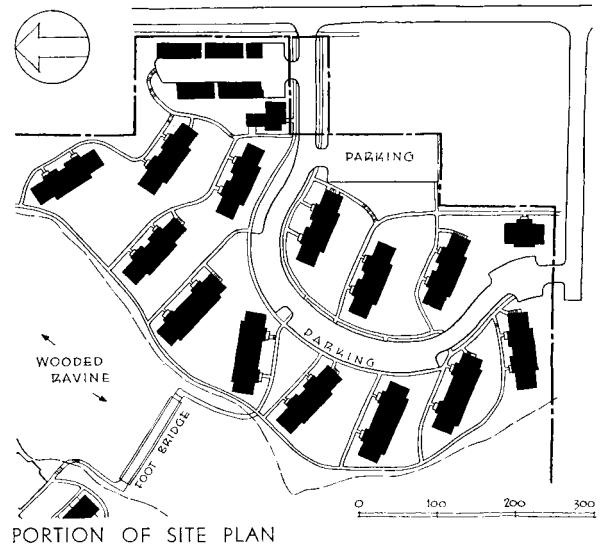
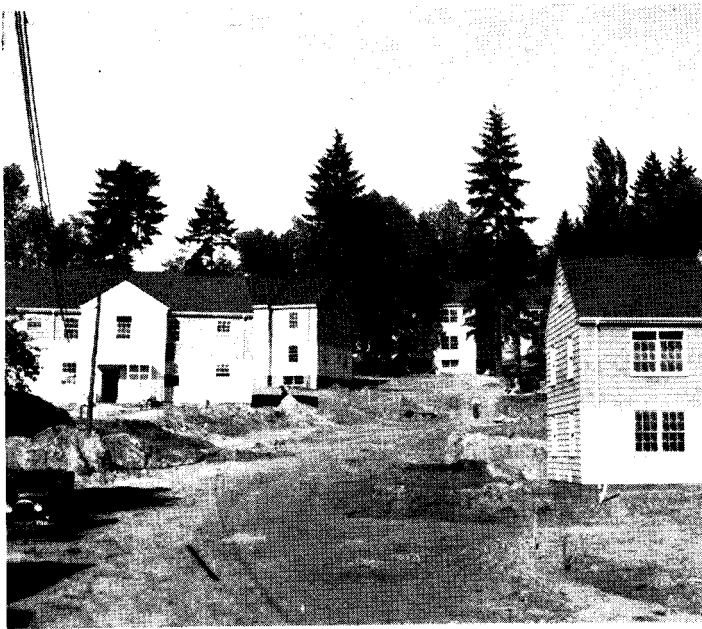

HOUSING PLANNED FOR WOODED SITE

BREMERTON GARDENS, BREMERTON, WASHINGTON. GRAHAM & PAINTER, ARCHITECTS. Hills, wooded ravines, and a view of Port Washington Narrows set the pattern for this project of Defense Homes Corporation. The site plan was developed to take advantage of views and still conform to natural contours, also to preserve trees. Character of the site also influenced the design, a domestic feeling being achieved with cedar siding, vertical boards and pre-dipt shingles in red, brown and green. Garages are provided; also laundry rooms in the basements. Heating is by forced-flow hot water boilers, with oil burners. Conventional frame construction.



TYPICAL EIGHT-UNIT BUILDING

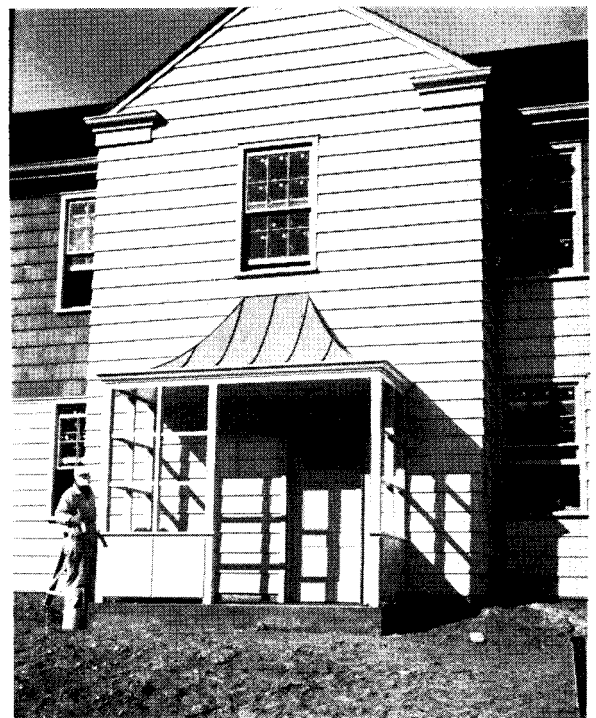
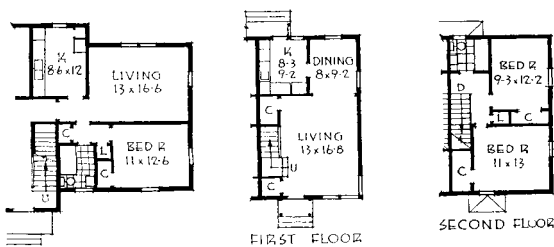

ENTRANCE DOORWAY

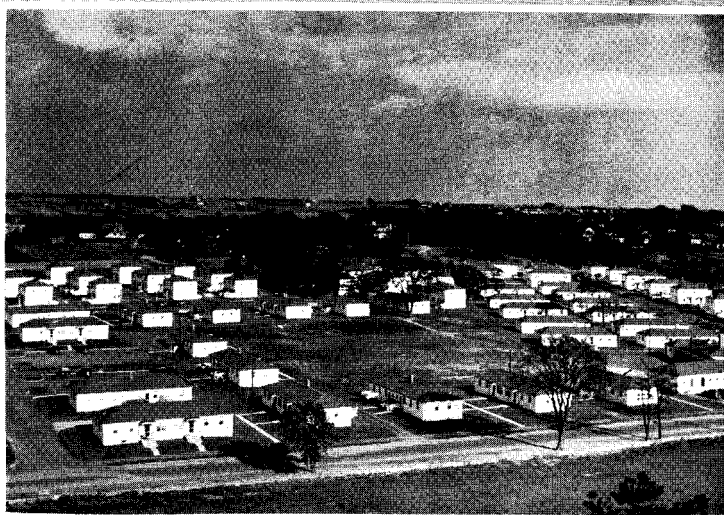

GENERAL VIEWS

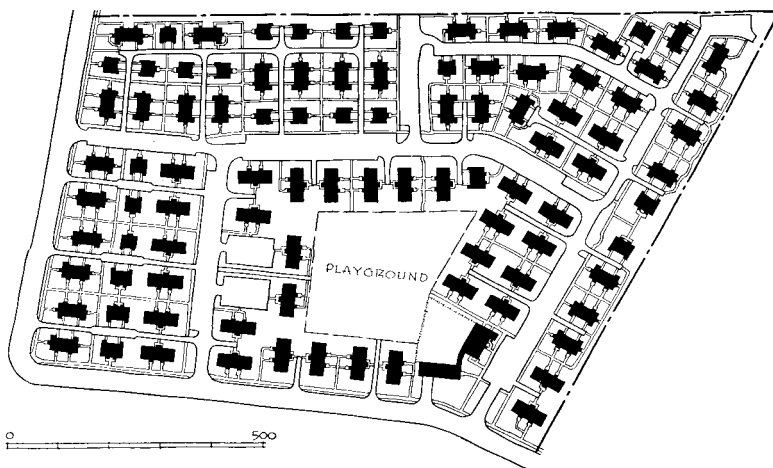

PERMANENT HOUSING

PARKHOLM DEFENSE HOUSING PROJECT, NEWPORT, RHODE ISLAND. EDWARD H. WIGHAM, ARCHITECT; W. L. VAN ALEN, ASSOCIATE. A natural addition to a city that has always had military and naval stations, this project could follow no general formula for housing. Geographically and historically a part of the city, it needed thorough integration in both design and construction. For the same reason the site plan was kept as informal as possible. Where grades permit, roads have no curbs, or the curbs are on only one side. Except on main traffic ways, foot walks follow natural flow lines of pedestrian traffic. Parking is provided for 100 per cent car ownership off the cartway of the main road, to reduce the hazards of traffic conflicting with pedestrian circulation, and to permit the green areas around the houses to be as large as possible. These

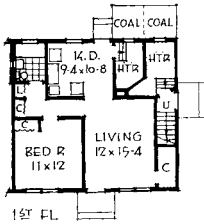
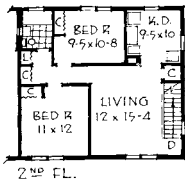

WALKS follow natural flow lines of pedestrian traffic

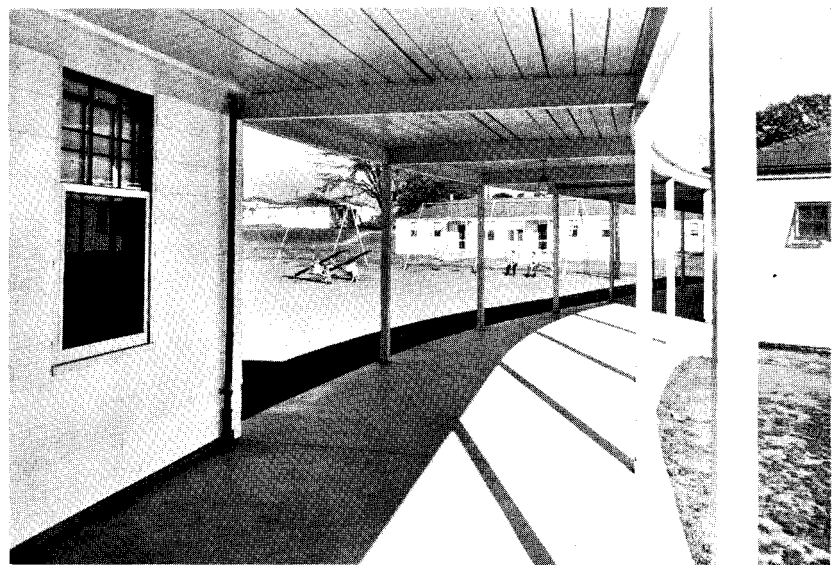
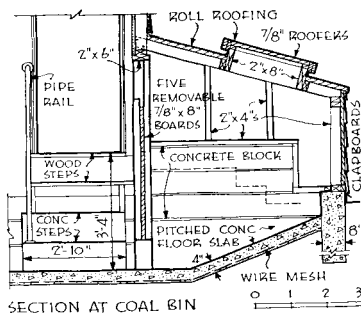

COVERED WALK between office and recreation buildings

FOR NEW ENGLAND

areas are so arranged that virtually all of the lawns are maintained by tenants; and each tenant has ground for a small garden. Wood frame construction was used, with pitched roofs in the New England tradition, because it has proved economical, and quite durable. Asbestos siding was chosen to reduce maintenance costs, and double-hung windows for protection from the excessive moisture and high winds of the locality. All units are heated by individual tenant-maintained heaters, of the gravity-fed hot water type, with expansion tank in the attic and overflow lines down to the crawl space under the building. Each living unit has a small utility room on the ground floor, containing hot water boiler and domestic water heater. Behind each utility room is a small outdoor coal bin (see sectional detail above), with a capacity of slightly over two tons.



KITCHEN and dining space viewed from living room

Photos by Cushing-Gallaty

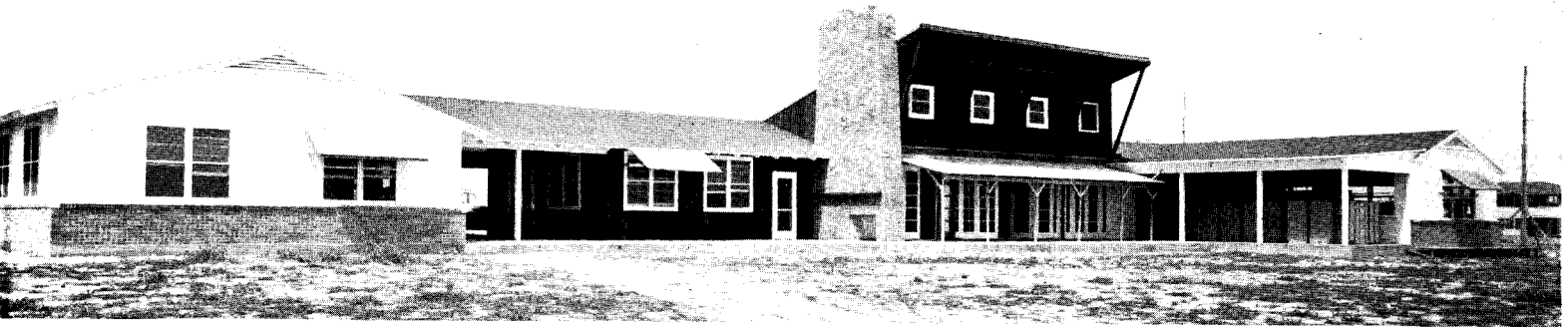

COMMUNITY HOUSE

WITH BENEFIT OF LOCAL PLANNING

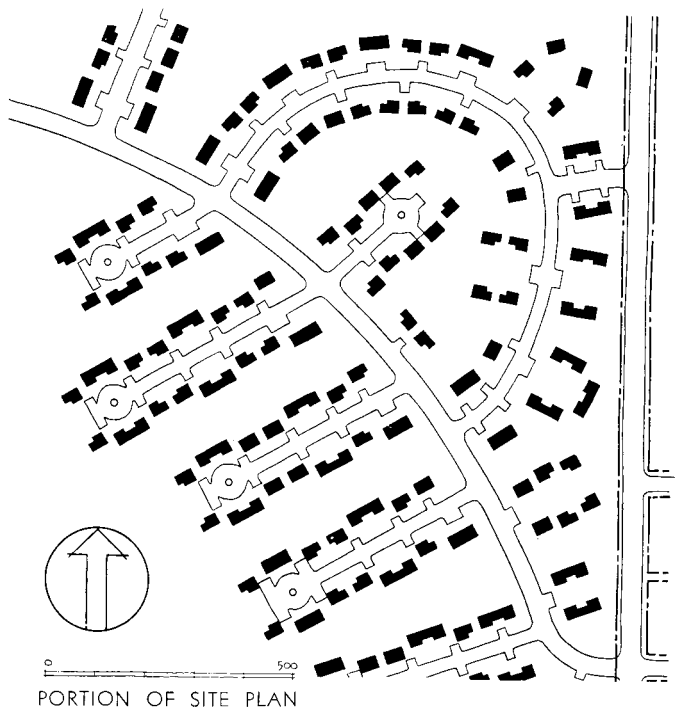

DALLAS PARK HOUSING PROJECT, DALLAS, TEXAS. BURNS ROENSCH, ARCHITECT. With benefit of local planning, this 550-unit project of the Mutual Ownership Defense Housing Division, FWA, escaped the fate of many a project planned in Washington. For in Texas orientation is all-important, in both site and building plans. In the final layout, though it required a bit more than minimum grading, nearly all buildings face directly into the breeze. Cul-de-sacs were treated more as service courts, with parking areas, than as entrance streets, leaving garden space for outdoor living. Because buildings had to be close together, all side walls were kept blank to afford maximum privacy, also to allow for future installation of car ports. Maximum cross ventilation was achieved by making front and rear walls a bank of windows. Because of the warm climate, *eating space* was provided in living rooms rather than in kitchens. Overhanging eaves afford protection from the hot sun, and add a suggestion of the Texas farm house.

Photos by George E. Marshall Studio

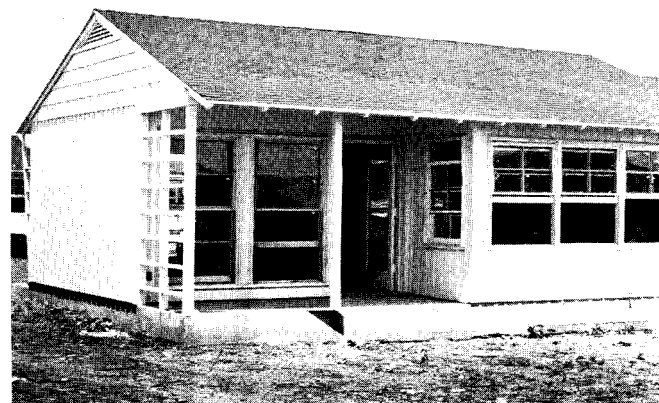

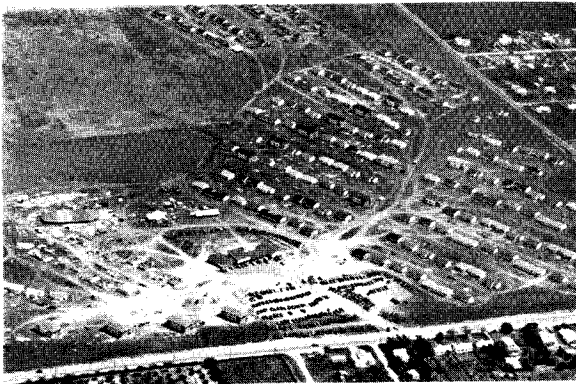

AIR VIEW during construction

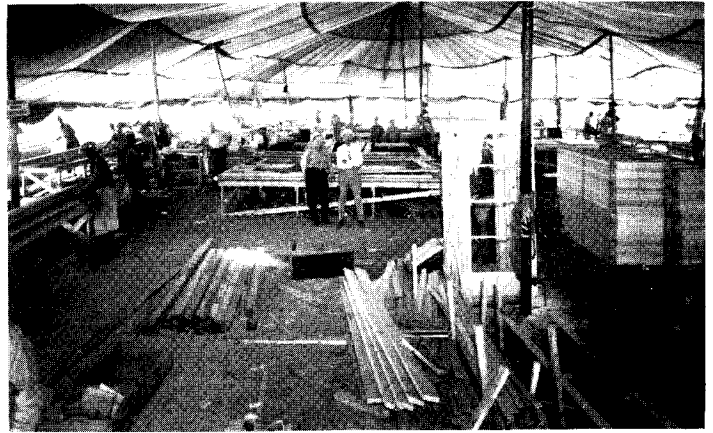

PREFABRICATION TENT for jig table operations

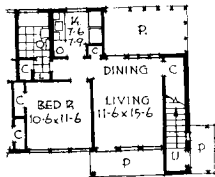
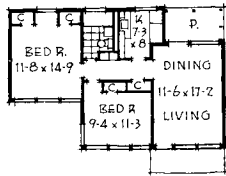

CONCRETE SLAB FLOORS and foundations

EXTERIOR walls and roof trusses were prefabricated under a tent located on the job, and taken by truck to building sites. Dry wall construction was used for interiors, with coated fabric finish. Concrete slab floors and grade beams, which proved no more expensive than other types, were poured monolithically. Slabs, poured over gravel fill covered with felt, were reinforced with wire mesh; beams with 1/2-inch bars. Finish floor is asphalt tile set in mastic. Factory-finished oak flooring was used for second stories.

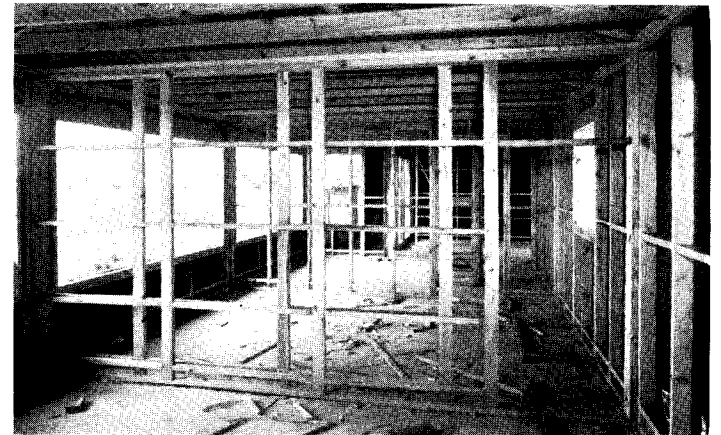

PREFABRICATED PANELS and roof trusses in place

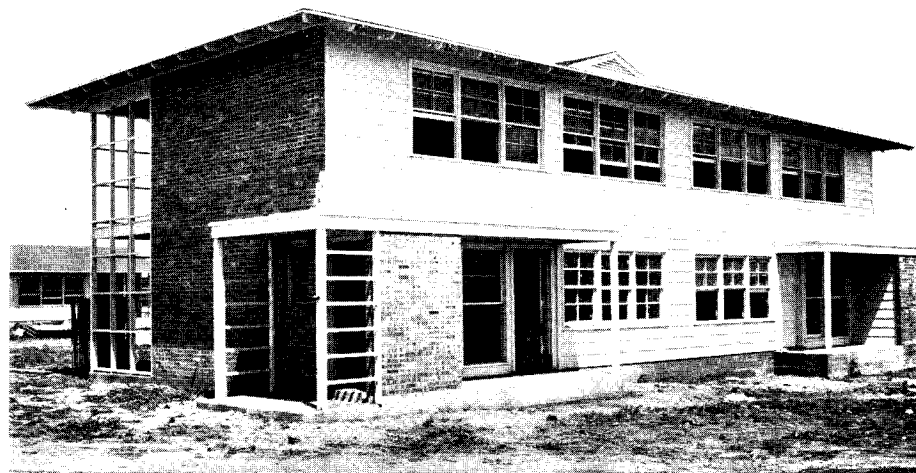
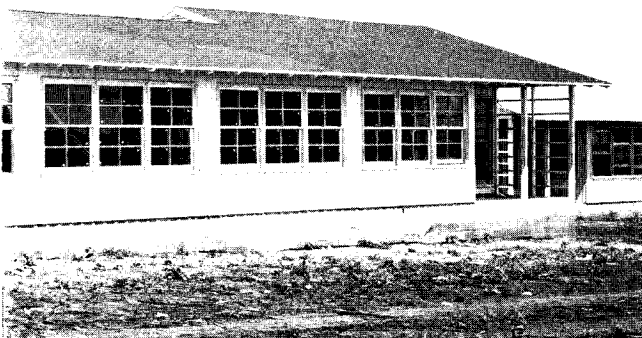



DEVELOPMENT OF A PARK SITE

RAHWAY RIVER PARK PROJECT, RAHWAY, NEW JERSEY. JOHN T. ROWLAND, ARCHITECT. Almost wholly surrounded by a park along the Rahway River, the site for this project of the Mutual Ownership Defense Housing Division, FWA, offered unusual possibilities. Requirements for the site plan were: economy; as much free garden and play space as possible; and natural development of contours. The houses follow closely the "typical" plan regarded as most economical for defense housing, but the designs are individual in the elimination of pitched roofs and the emphasis of lateral lines in both form and color. Corner windows were used where possible, thus adding interior wall space, yet not losing light or air.

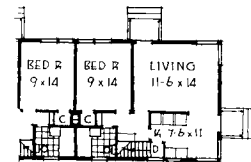
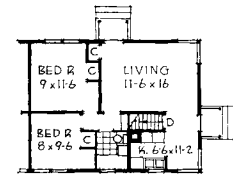

Renderings by Alan C. Dacoll, Louis Dreyer, photographer.

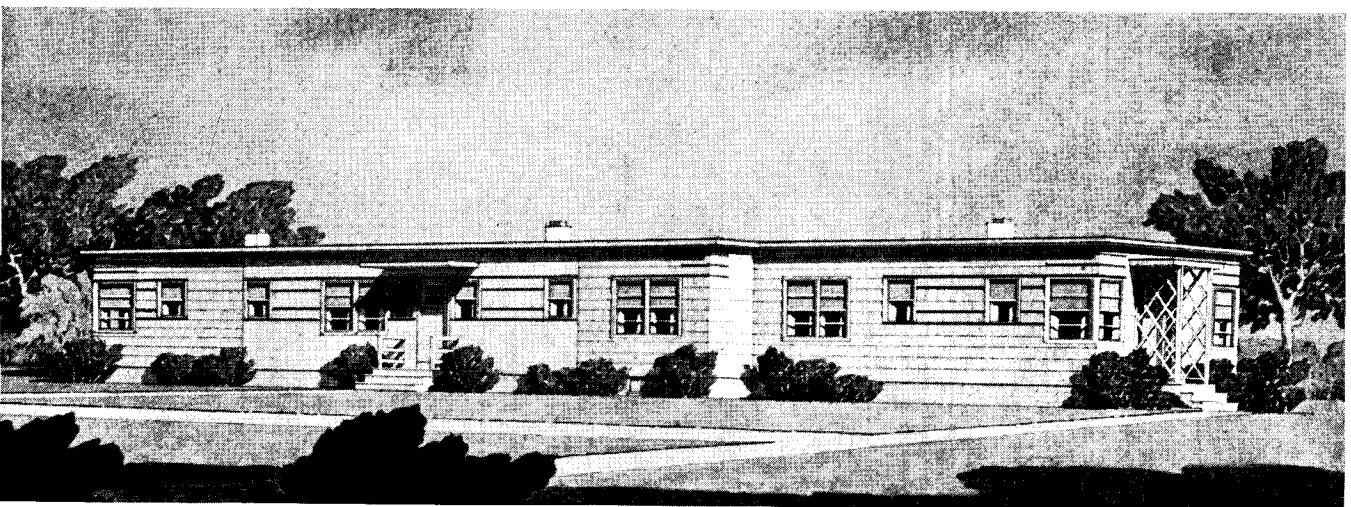

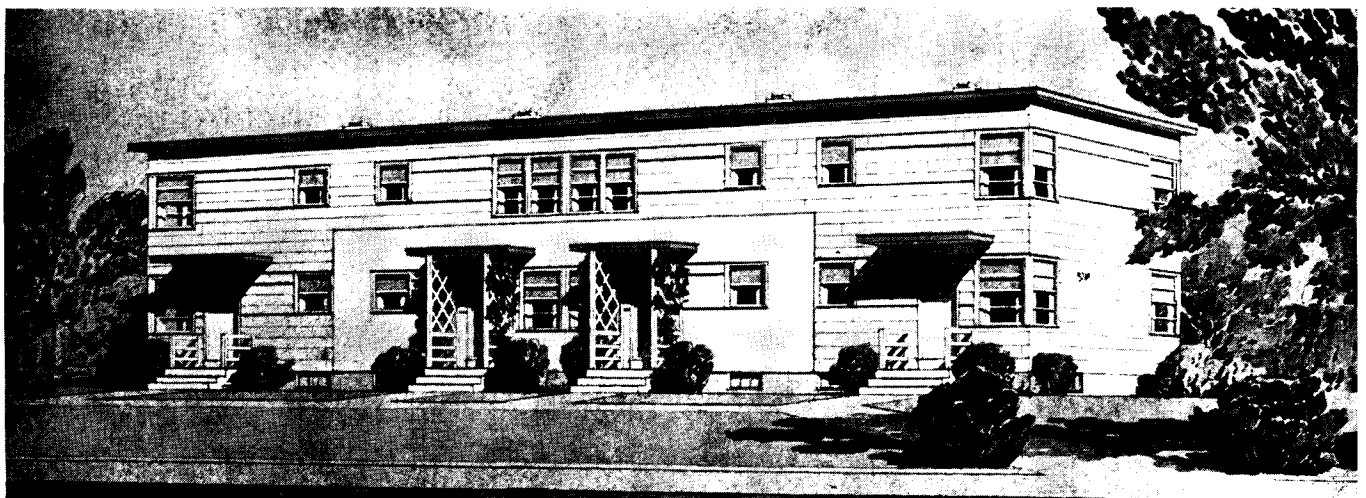
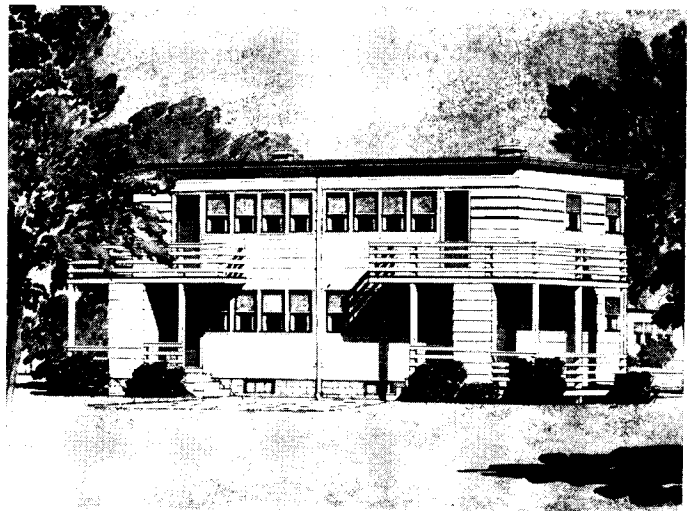
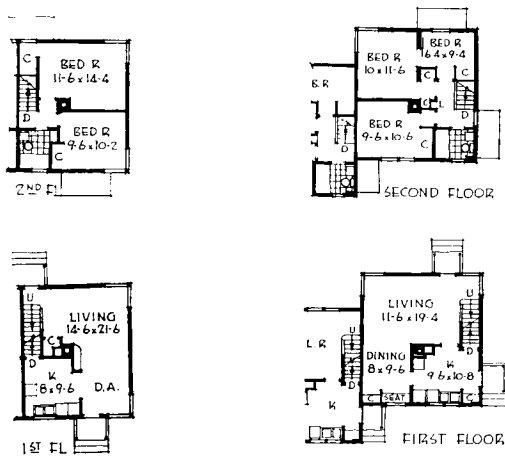
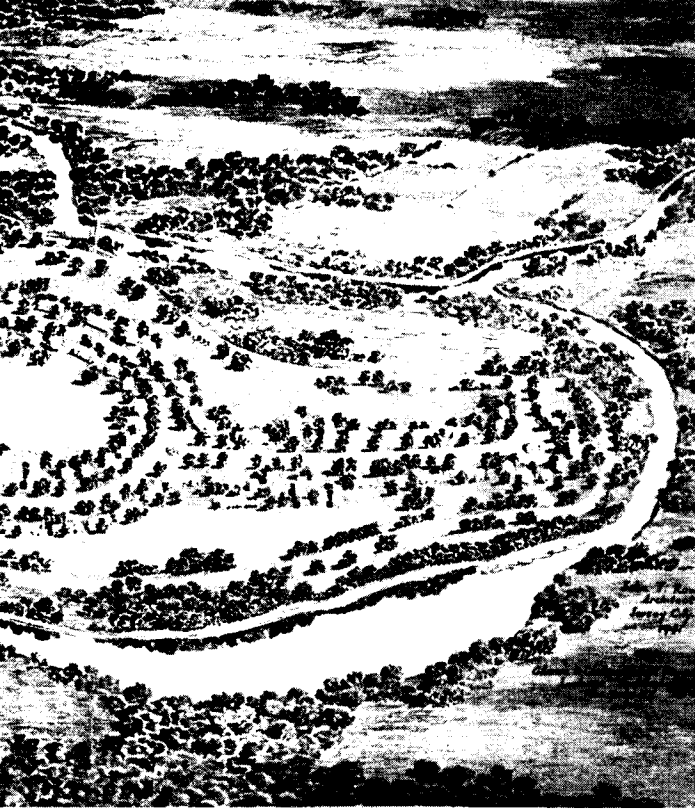

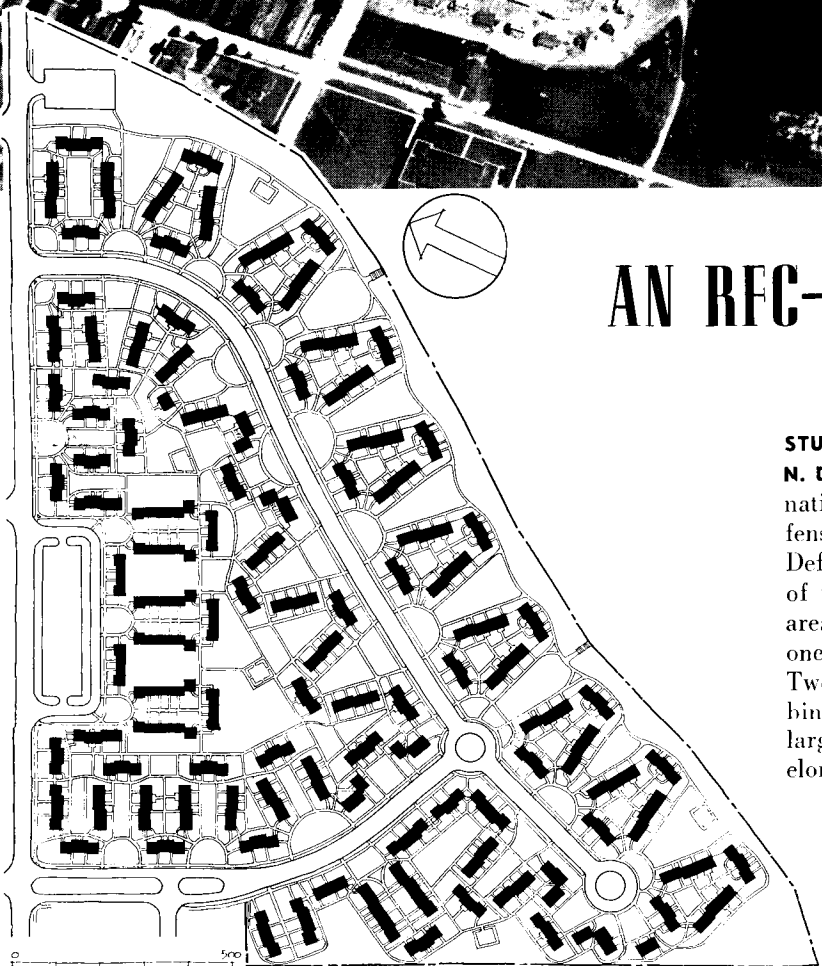
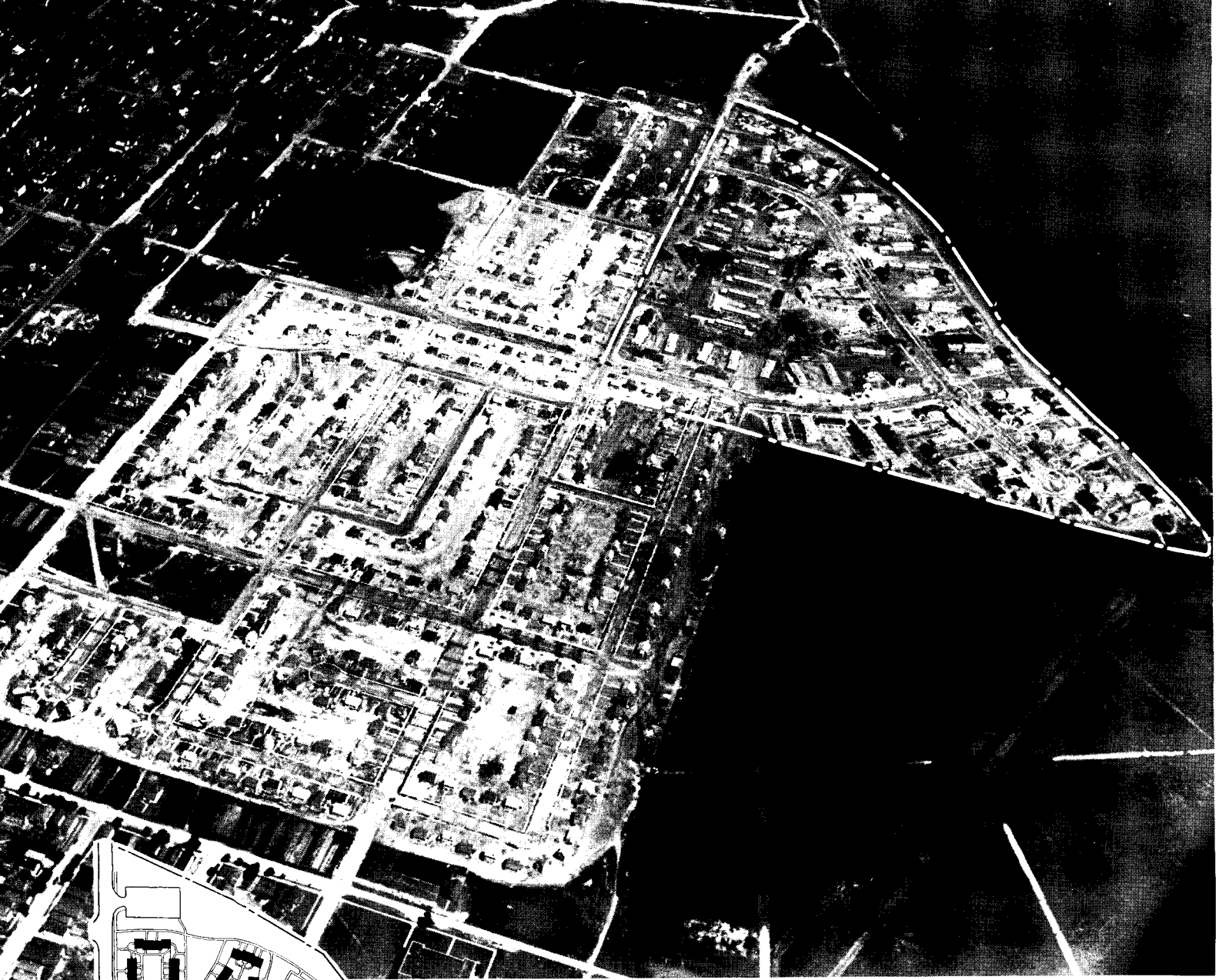

AN RFC—FHA COLLABORATION

STUART GARDENS, NEWPORT NEWS, VIRGINIA. WILLIAM N. DENTON JR., ARCHITECT. Warranting special examination as an exemplification of FHA standards for defense housing, this is one of the larger projects of the Defense Homes Corporation, RFC subsidiary, and one of the larger undertakings in the busy Hampton Roads area. Several hundred one-family houses are grouped in one section, adjoining a rental community of 500 units. Two distinct site plan solutions are interestingly combined. The one for the individual houses was directed largely by the city plan, calling for a grid pattern of elongated blocks. Some cul-de-sacs were allowed, to relieve the monotony, and changes in set-backs permitted variation of the street frontages. The angular pattern of the site plan for the group houses (section shown at left) was developed so that 60 per cent of the 500 rental units have a view of the water.

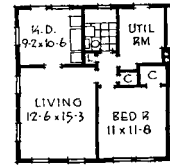
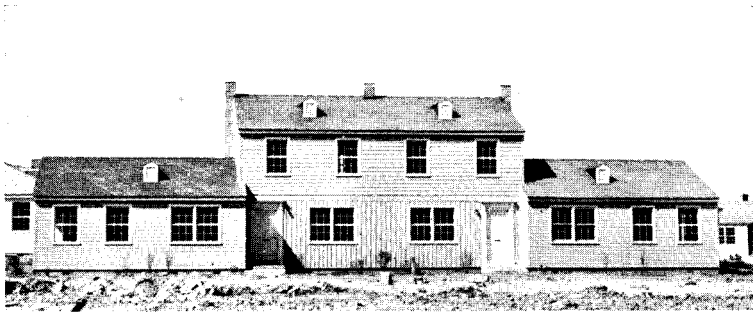
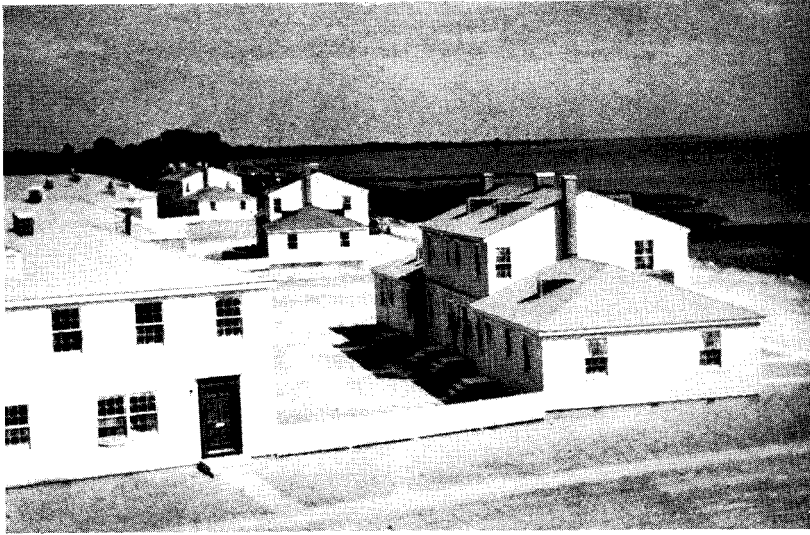

Unit A

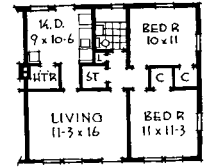

Unit B

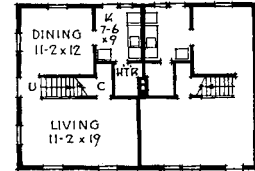

FIRST FLOOR

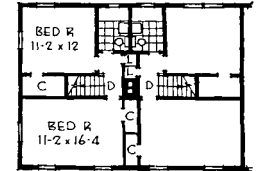

SECOND FLOOR

Unit C

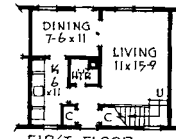

FIRST FLOOR

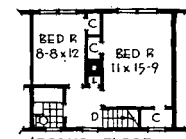

SECOND FLOOR

Unit D

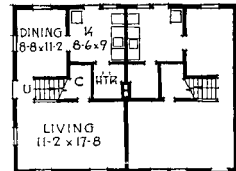

FIRST FLOOR

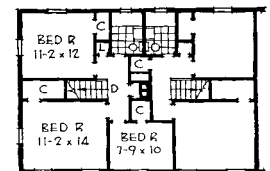

SECOND FLOOR

Unit E

THREE basic floor plans were used for 479 individual houses. With some variations, and with the addition of two other types, the same basic plans served for the rental units. Variations in exteriors were achieved with several combinations of beveled siding, vertical boards and battens, and flush siding; also with pitched and gabled roofs, front and side porches, different color combinations, and, of course, reversal of plans. Thus 30 types were developed. There were three roof colors, four wall colors, and four shutter and front door color combinations. Conventional construction was used, with 2-inch mineral wool insulation in all top-floor ceilings. Heating is by individual forced warm air furnaces with oil burners.

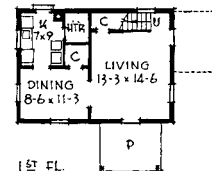

1ST FL.

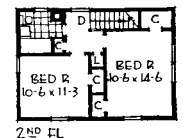

2ND FL.

Unit F

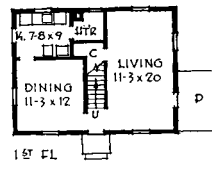

1ST FL.

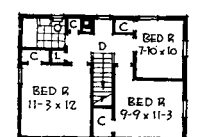

2ND FL.

Unit G

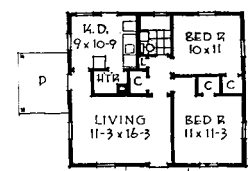

Unit H

MULTI-FAMILY UNITS

SINGLE FAMILY UNITS

George Schopfer



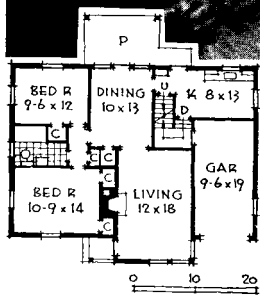
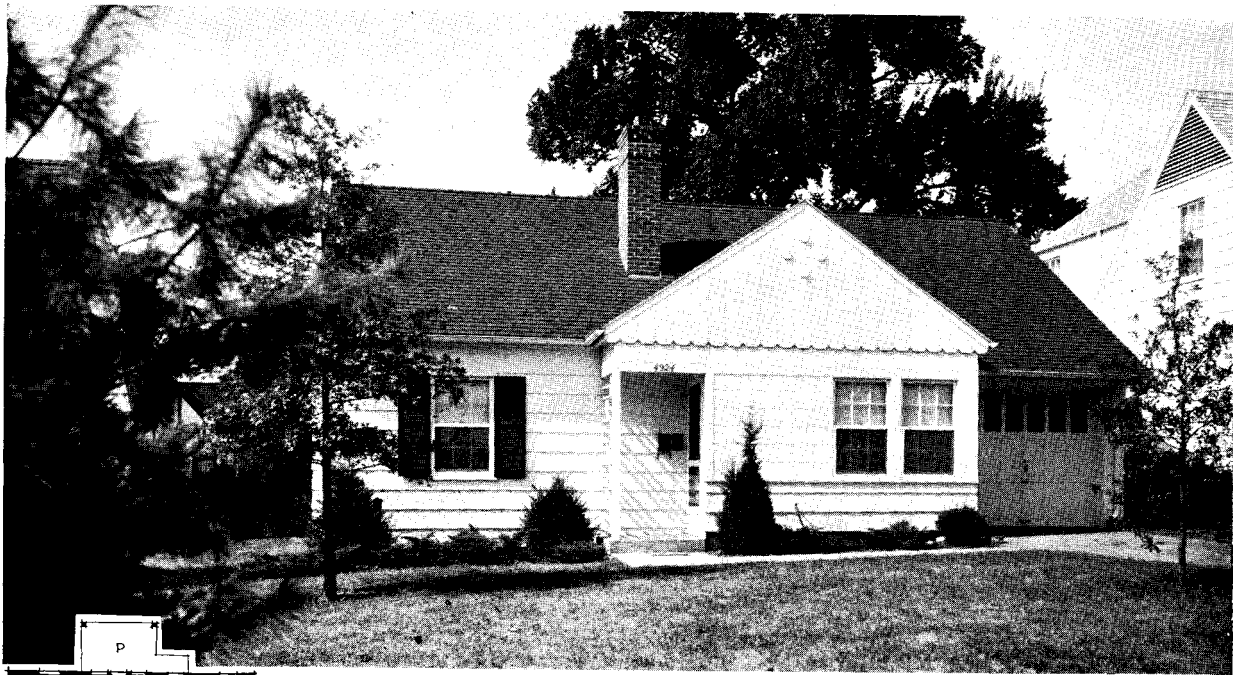

4924 STATE LINE ROAD. Country Club District, Kansas City

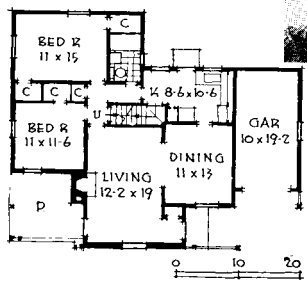

5424 NORWOOD ROAD. Country Club District, Kansas City

Photos by Tyner-Murphy

DEFENSE HOUSING IN A SUBDIVISION

HOUSES BUILT FOR SALE, J. C. NICHOLS COMPANIES, KANSAS CITY. EDWARD W. TANNER, ARCHITECT.

With private enterprise expected to supply the bulk of housing needed in defense areas, subdivision developers and their designers will be concentrating on the low-cost house. Those fortunate enough to have a low-cost development already in operation, in a defense area, may go merrily ahead under the priority system. And they

will be making the best possible contribution to the defense housing program, at the same time furthering the community's permanent development. There will be difficulty in attaining the desirability of these two Nichols houses within the \$6,000 maximum for house and lot permitted in the priority order. Much can be done to maintain the subdivision's standards by leaving out, for the present, all possible "extras."

1—WATER SUPPLY PIPING

THIS and subsequent sheets in this series present in brief the simplified, safe standards for plumbing practice advocated by the U. S. Department of Commerce's National Bureau of Standards (BMS 66). Purpose of BMS 66 is to reduce quantities of material required, and thus reduce costs. The same design procedure was adopted by the USHA for defense housing (August 1941), even to the extent of requiring that USHA standards supersede local codes. These six sheets have been prepared by Burton A. Bugbee, Architect. They apply only to one- and two-story residential buildings.

It is assumed that an adequate supply of potable water and satisfactory sewage disposal facilities are available.

PIPING

Sizes of building mains and distribution piping for typical simple installations are shown in accompanying diagrams. Minimum building main is 3/4 in.; if flush valves are used, 1 in. Pipe sizes should give minimum pressure at any one fixture outlet, at peak load, of 8 lb. per sq. in. For more complex installations, actual sizes of piping should be determined by standard tables (see BMS 66) of fixture unit ratings and flow charts. Factors governing selection are: 1. Number and types of fixtures supplied; 2. Length of piping and friction loss of fittings; 3. Probable reduction in diameter by corrosion, depending on water analysis and piping materials.

Materials: Selection of piping should be governed by analysis of water; may be brass, copper, cast or wrought iron, cement-lined, lead or steel, with approved fittings. For cold water systems use ferrous piping for slightly and moderately corrosive waters; non-ferrous or lined piping for corrosive waters. For hot water systems use ferrous piping for slightly corrosive waters; non-ferrous for moderately corrosive and corrosive waters. Lead piping must not be used in water supply until it has been determined that no poisonous lead salts are produced by contact of lead with the particular water supply. Avoid combinations which may produce electrolysis.

INSTALLATION

All connections to risers and fixtures should be made from top of mains, with all lines pitched to a low point for draining. Sill cocks should be approximately 18 in. above grade and require accessible shutoffs and drains. All water pipes and appliances subject to freezing temperatures should be protected by burying below frost line, or by insulating.

Valves. Provide stop and waste valve at entry point of service main. In single dwelling unit install valve under sink to control all fixtures in unit. In multiple dwelling units install individual stops for fixtures as follows:

- 3/8" plain wheel handle or screw driver stop for W. C.
- 3/8" plain wheel handle or screw driver stop for lavatory.
- 1/2" plain wheel handle or screw driver stop for sink.
- 1/2" concealed screw driver stop for bath.

Backflow. Every supply outlet or connection to a fixture or appliance should be protected from backflow by an approved air gap or backflow preventer between control valve of the outlet and the fixture or appliance (see table).

HOT WATER SUPPLY

Materials for even moderately corrosive waters should be non-ferrous or coated. Heater should be located as near fixtures as possible to reduce heat loss. Selection of hot water heaters should be based on size of unit, water characteristics, and fuel selection. Relief valve should be installed in each hot water system, so located that there is no shut-off or check valve between the tank and the relief valve.

SIZE OF FIXTURE BRANCHES AND OTHER OUTLETS

| Fixture, etc. | Size, inches |
|--|--------------|
| Sill cocks | 1/2 |
| Domestic water heaters | 1/2 |
| Laundry trays | 1/2 |
| Sinks | 1/2 |
| Lavatories | 3/8 |
| Bathtubs | 1/2 |
| Water closets (tanks) | 3/8 |
| Water closets (flush valves) | 1 |
| Urinals, pedestal, flush valves | 1 |
| Urinals, wall or stall, flush valves | 1/2 |

AIR GAPS REQUIRED

| Fixture, Fitting | Min. Air Gap (inches) see notes* | |
|---|-------------------------------------|-----------------|
| | Ordinary Conditions | Spout near Wall |
| Lavatory supplies, effective opening up to 1/2" | 1.0 | 1.5 |
| Sink, laundry tray, bath (gooseneck) faucets, effective opening up to 3/4" | 1.5 | 2.25 |
| Bath, over-rim fillers, effective opening up to 1" | 2.0 | 3.0 |
| Any fitting, effective opening greater than 1", multiply effective opening by | 2 | 3 |
| Drinking fountain nozzles | 0.75 | — |

*Notes

Spout near wall: If any vertical wall extending to or above the spout opening is closer to the nearest inside wall of the spout opening than four times the diameter of the effective opening, the air gap shall be as specified above for spout near wall.

Spout at angle: Should the plane of the end of the spout be at an angle to the surface of the water, use mean gap for measurement, except use lowest point of drinking-fountain nozzles.

HOT WATER SUPPLIES: MIN. SIZES (inches)

| | |
|--|-----|
| Lavatories | 3/8 |
| Bathtubs | 1/2 |
| Sinks and combination sink-trays | 1/2 |

WATER HEATER CAPACITIES

| Fuel Type and Tank Material | If Demand Charge, Tank Size and Fuel Input for Units with: | | If No Demand Charge, Tank Size and Fuel Input for Units with: | |
|--|--|------------|---|------------|
| | 1 or 2 Bedrooms | 1 Bedroom | 2 Bedrooms | 2 Bedrooms |
| Gas: Ferrous | 28 Gal. | 20 Gal. | 28 Gal. | 28 Gal. |
| | 5000 Btu | 10000 Btu | 10000 Btu | 10000 Btu |
| Nonferrous or lined | 20 Gal. | 9-15 Gal. | 9-15 Gal. | 9-15 Gal. |
| | 5000 Btu | 10000 Btu | 15000 Btu | 15000 Btu |
| Oil: Ferrous, nonferrous or lined | — | 20 Gal. | 28 Gal. | 28 Gal. |
| Electric: Ferrous, nonferrous or lined | 30 Gal. | 30 Gal. | 30 Gal. | 30 Gal. |
| | 600-1000 W | 600-1000 W | 600-1000 W | 600-1000 W |
| Coal: Ferrous, nonferrous or lined | — | 30 Gal. | 30 Gal. | 30 Gal. |

PLUMBING SYSTEMS for DEFENSE and LOW-COST HOUSING

1-WATER SUPPLY PIPING

NOVEMBER 1941

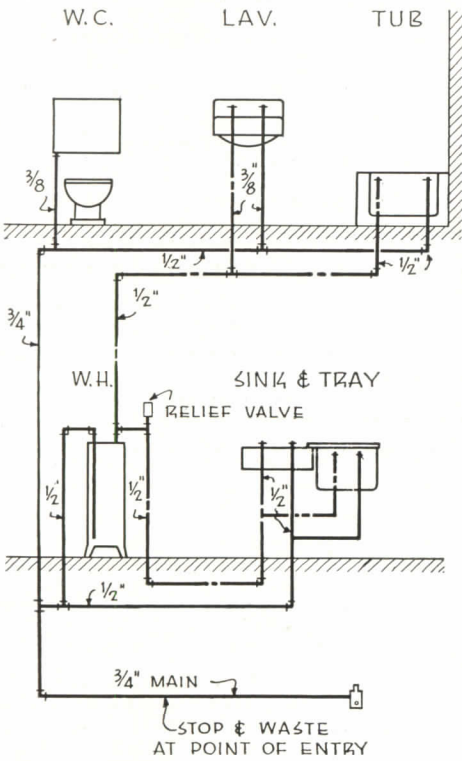
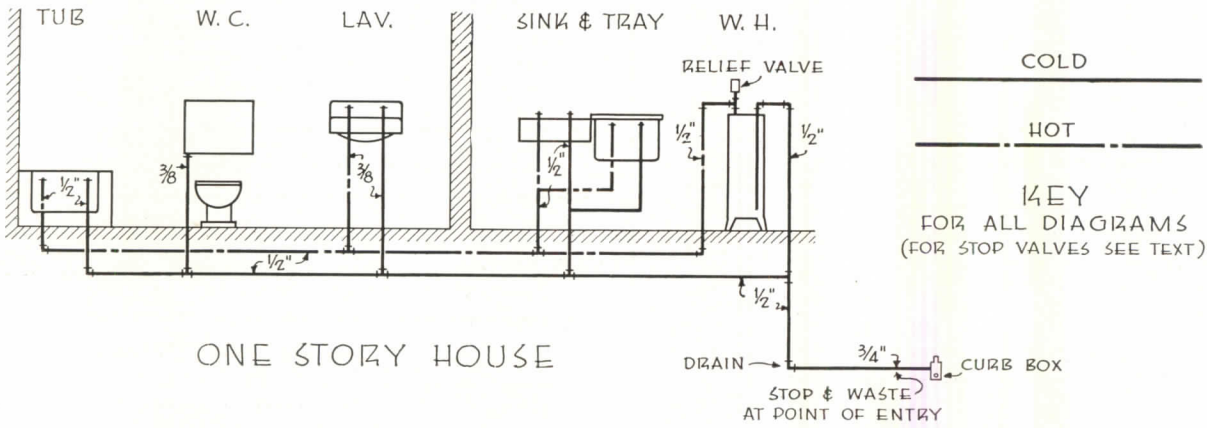

TWO STORY HOUSE
 OR ROW HOUSE

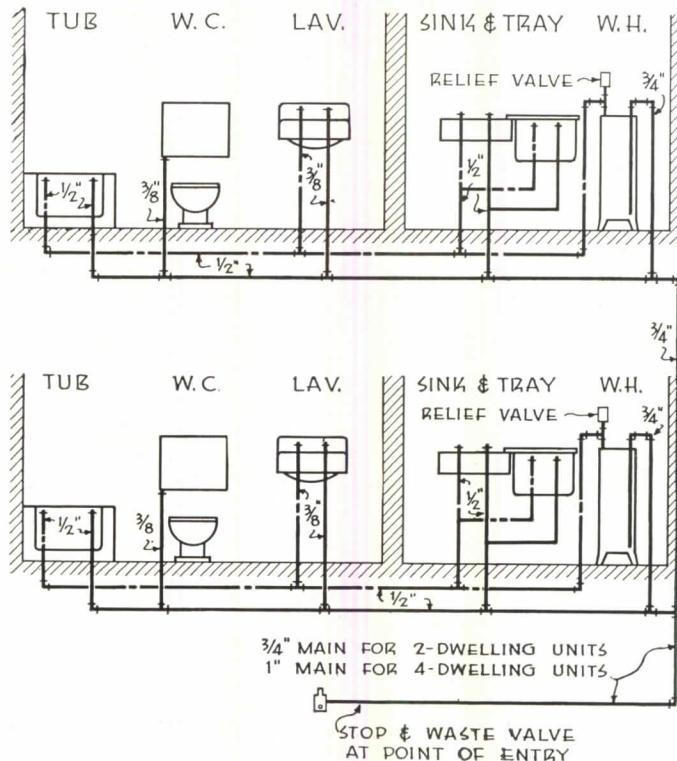

TWO STORY
 FLATS

PLUMBING SYSTEMS for DEFENSE and LOW-COST HOUSING

2-DRAINAGE DIAGRAMS and DEFINITIONS

ARCHITECTURAL RECORD
TIME-SAVER
STANDARDS

NOVEMBER 1941

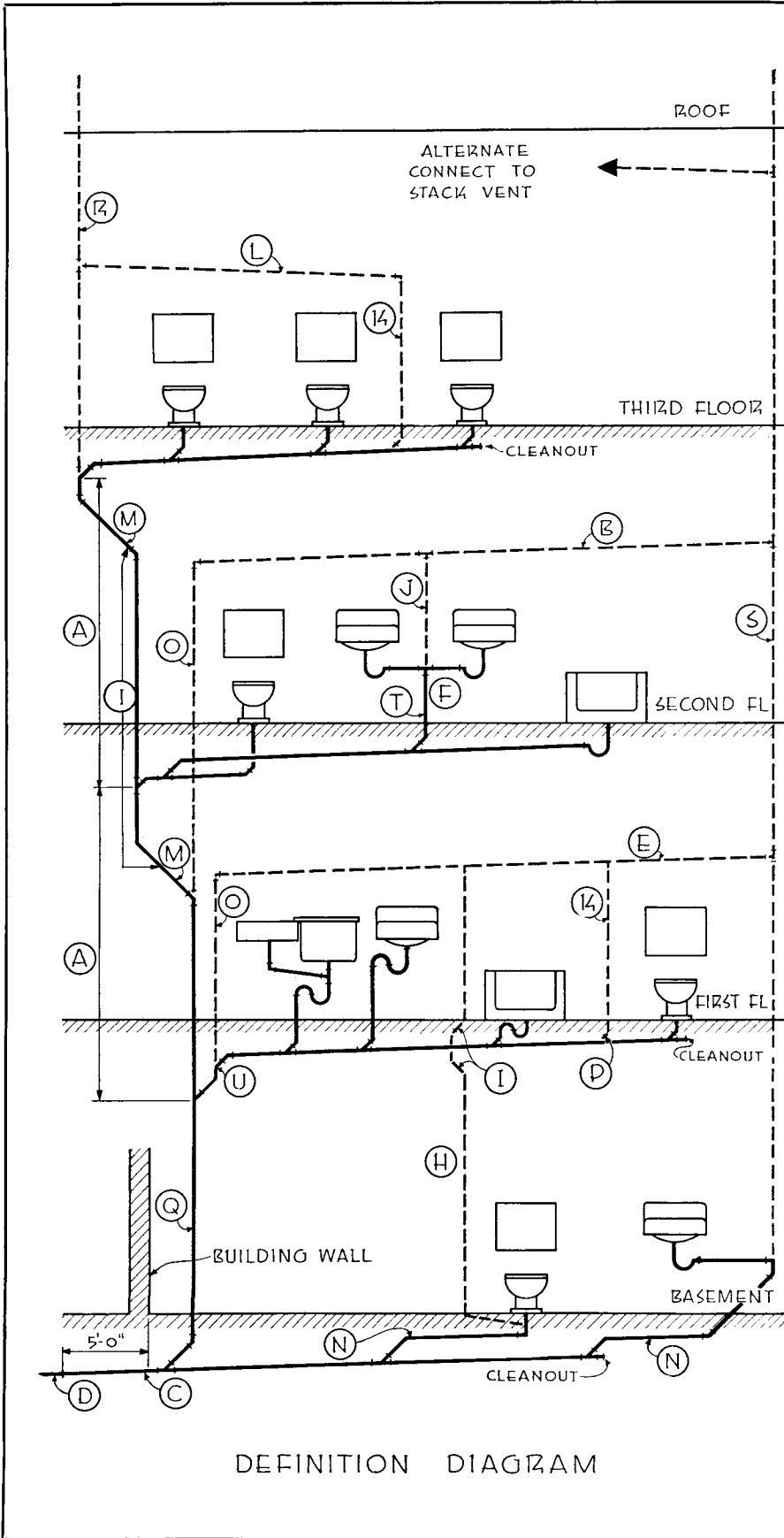

A. BRANCH INTERVAL: Length of soil or waste stack, not less than 8 ft.; in general a story height within which horizontal branches for one story connect to stack.

B. BRANCH VENT: Any vent pipe from drainage branch to vent stack.

C. BUILDING DRAIN: Final horizontal member receiving discharge of all drainage pipes, and connecting with building zonal branch to vent stack.

D. BUILDING SEWER: Horizontal member connecting building drain with street sewer or other sewage disposal means.

E. CIRCUIT VENT: Group vent extending from in front of last fixture of horizontal branch to vent stack.

F. CONTINUOUS WASTE AND VENT: A vent that is a continuation of and in a straight line with the drain to which it connects.

G. CONTINUOUS WASTE: A waste from two or more fixtures connected to a single trap.

H. DRY VENT: Any vent that does not carry water or water-borne waste.

I. DOUBLE OFFSET: Two offsets in series in same line.

J. DUAL VENT (UNIT VENT): A group vent connecting at the junction of two fixture branches and serving as vent for both branches.

K. GROUP VENT: A branch vent that vents two or more traps.

L. LOOP VENT: A group vent extending from in front of last fixture on a horizontal branch to a stack vent.

M. OFFSET: A combination of elbows or bends which brings one section of pipe out of line but parallel to another section.

N. PRIMARY BRANCH: Sloping drain from base of soil or waste stack to junction with building drain.

O. RELIEF VENT: A branch from the vent stack connected to a horizontal branch between the first fixture branch and the soil or waste stack.

P. SIDE VENT: A vent connecting to the drain pipe through a 45° wye.

Q. SOIL STACK: A vertical main which carries the discharge of water closets with or without discharge of other fixtures.

R. STACK VENT: The extension of a soil or waste stack above the highest drainage connection.

S. VENT STACK (MAIN VENT): A vertical vent pipe.

T. WET VENT: A soil or waste pipe that also serves as a vent.

U. YOKE VENT: A relief vent of the continuous-waste-and-vent type formed by the extension of a wye-branch inlet of the horizontal branch to the stack.

PLUMBING SYSTEMS for DEFENSE and LOW-COST HOUSING

3-DRAINAGE PIPING SELECTION, INSTALLATION

NOVEMBER 1941

THE SIX PAGES in this series present in brief the simplified, safe standards for plumbing practice advocated by the U. S. Department of Commerce's National Bureau of Standards (BMS 66). Purpose of BMS 66 is to reduce quantities of material required, and thus reduce costs. The same design procedure was adopted by the USHA for defense housing (August, 1941), even to the extent of requiring that USHA standards supersede local codes. These six sheets have been prepared by Burton A. Bugbee for one- and two-story residences.

SOIL AND WASTE LINES

Traps. Should be self-cleaning, of same sizes as fixture drains to which they are connected (see table). Trap each fixture separately, as near fixture as possible, except that continuous wastes with single trap may be used with combination sink and laundry trays, or with a set of not more than three laundry trays or lavatories. Each fixture trap should have a water seal of not less than 2 in. nor more than 4 in.

Cleanouts. Accessible cleanouts are required at the foot of each soil or waste stack, at each change of direction of building drain if greater than 45°. Cleanouts are required every 50 ft. in horizontal soil lines.

Piping. Extra-heavy cast iron soil pipe and fittings are preferred; standard weight may be used in one- or two-story buildings. Underground, extra-heavy only is permissible. Sizes of soil and waste piping should be determined by standard fixture unit ratings as shown in accompanying tables.

INSTALLATION

Connect building drain to sewer within 5 ft. outside of the walls as indicated on drawings. Building drain should receive all connections from soil, waste and drainage stacks.

Erect soil, waste and vent stacks of sizes shown and extend above roof. Soil stacks should be run full size through roof, and should not be less than 3 in. in diameter. Branch soil, waste and vent connections are run to the soil stack, waste stack, building drain or vent stacks as shown or required.

Support. Piping has to be rigidly supported and run in practical alignment. Install piping without undue strains or stresses. No structural member can be weakened or impaired by cutting, notching or otherwise, unless provision is made for carrying the structural load.

Changes in direction in drainage piping have to be made by appropriate use of 45° wyes, long sweep sixth, eighth, or sixteenth bends, or by combinations of these fittings; or by use of equivalent threaded fittings or their combinations, except that sanitary tees may be used on vertical stacks and short quarter bends may be used in drainage lines where the change in direction of flow is from the vertical to the horizontal. Tees and crosses may be used in vent pipes. No change in direction greater than 90° shall be made in drainage pipes. Where different sizes of pipes and fittings are to be connected, standard increasers and reducers shall be employed. Reduction of size of drain pipes in the direction of flow is prohibited (except 4 x 3 in. W. C. connection).

Drilling and tapping of house drains, soil, waste, or vent pipes, and use of saddle hubs and bends, are prohibited.

Protect from breakage pipes passing under or through walls. Protect against external corrosion, pipes passing through or under cinder concrete or other corrosive material. Protect pipes and traps from freezing by burying or by insulation.

Joints and connections should be made permanently gas- and water-tight. All exposed threads on ferrous pipe require a coat of acid-resisting paint. Joints in vitrified clay and concrete pipe or between such pipe and metal should be hot-poured asphaltum compound or cemented joints. Pack hot-poured joints with approved packing and fill with approved jointing compound at one pouring. Pack cemented joints with approved packing, secured with portland cement. Calked joints on cast-iron soil pipe must be firmly packed and secured with well-calked lead, not less than 1 in. deep.

Screwed joints are made with a lubricant on the male thread only. Remove all burrs or cuttings. *Cast-iron joints* may be either calked or screwed. *Wrought iron, steel or brass* to cast-iron joints may be either screwed or calked joints. *Wiped joints* in lead pipe or between lead pipe and brass pipes,

| MINIMUM SIZES of TRAPS, FIXTURE DRAINS, in Inches | | | |
|---|-------|---------------------------|-------|
| Bathtubs | 1 1/2 | Sinks, kitchen | 1 1/2 |
| Combination fixtures | 1 1/2 | " , hotel or public | 2 |
| Drinking fountains | 1 1/4 | " , small, pantry | 1 1/4 |
| Floor drains | 2 | " , dishwasher | 1 1/2 |
| Laundry trays | 1 1/2 | " , service | 2 |
| Lavatories | 1 1/4 | Urinals, trough | 2 |
| Shower stalls | 2 | " , stall | 2 |

| NUMBER of FIXTURE UNITS per FIXTURE or GROUP | | | |
|--|---|--|----|
| Lavatory | 1 | Bathroom group | 8 |
| Water closet | 6 | " " , separate shower | 10 |
| Shower | 2 | Laundry trays, 2 or 3, single trap | 3 |
| Sink, service | 3 | Combination sink and tray | 3 |
| " , kitchen | 2 | Sewage ejector or sump pump, | |
| Bathtub | 2 | for each 25 gpm | 50 |

| SELECTION of HORIZONTAL BRANCH and STACK SIZES | | |
|--|---------------------------|----------------|
| Number of Fixture Units on One: | Diameter of pipe (inches) | |
| Horiz. Branch | Stack | |
| 1 | 2 | 1 1/4 |
| 3 | 4 | 1 1/2 |
| 6 | 10 | 2 |
| 32 | 48 | 3 (waste only) |
| 20 | 30 | 3 (soil) |
| 160 | 240 | 4 |
| 360 | 540 | 5 |
| 640 | 960 | 6 |

| CAPACITIES of HORIZONTAL and PRIMARY BRANCHES | | | | | |
|---|-------------------------------------|-------------------------------|----------|----------|----------|
| Diameter of pipe (inches) | Permissible Number of Fixture Units | | | | |
| | Horiz. Branch | Primary Branches at Pitch of: | | | |
| | | 1/16"/ft. | 1/8"/ft. | 1/4"/ft. | 1/2"/ft. |
| 1 1/4 | 1 | — | — | 2 | 2 |
| 1 1/2 | 3 | — | — | 5 | 7 |
| 2 | 6 | — | — | 21 | 26 |
| 3 (waste only) | 32 | — | 36 | 42 | 50 |
| 3 (soil) | 20 | — | 24 | 27 | 36 |
| 4 | 160 | — | 180 | 216 | 250 |
| 5 | 360 | 360 | 400 | 480 | 560 |
| 6 | 600 | 600 | 660 | 790 | 940 |

OFFSETS: If a single, double, or return offset, not over 45°, is installed in soil or waste stack, and provided no branch connects to stack within 4 diameters of sloping portion, number of fixture units can not exceed 1/2 above.

| MINIMUM PITCH for HORIZONTAL DRAINAGE PIPING | | | |
|--|---------------------|-----------------|---------------------|
| Diam. (in.) | Pitch (in. per ft.) | Diam. (in.) | Pitch (in. per ft.) |
| 1 1/4 to 2 | 1/4 | 5 to 8 | 1/16 |
| 2 1/2 to 4 | 1/8 | 10 and up | (see BMS 66) |

ferrules, soldering nipples, bushings, or traps, in all cases on the sewer side of the trap and in concealed joints on the inlet side of the trap, shall be full wiped joints, with an exposed surface of the solder on each side of the joint not less than 3/4 in. and a minimum thickness at the thickest part of the joint of not less than 3/8 in.

Lead to cast iron, steel, or wrought iron joints shall be made by means of a calking ferrule, soldering nipple, or bushing. *Copper tubing joints* shall be made in accordance with approved practice, either soldered or flanged. *Slip joints* and unions shall be used only in trap seals or on the inlet side of the trap. *Floor connections* for water closets and other fixtures shall be made by means of an approved brass or iron floor flange soldered securely or calked to the drain pipe. The joint between the fixture and floor flange shall be secured with an approved fixture setting compound or gasket.

Obstructions. Any fitting or connection which has an enlargement, chamber or recess with a ledge, shoulder or reduction of the pipe area, that offers an obstruction to flow through the drain, is prohibited.

PLUMBING SYSTEMS for DEFENSE and LOW-COST HOUSING

4-DRAINAGE PIPING INSTALLATION PRACTICE

ARCHITECTURAL DIVISION
**TIME-SAVER
 STANDARDS**

NOVEMBER, 1941

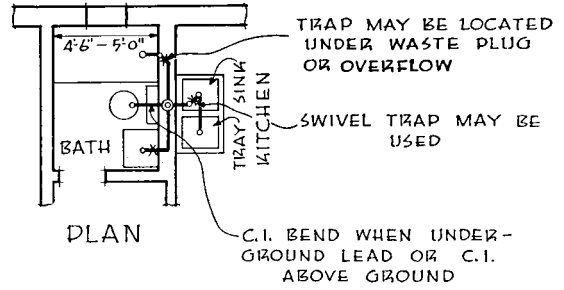
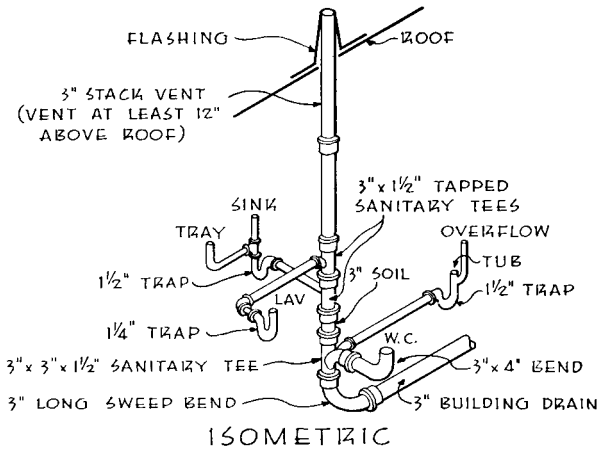

TYPICAL ONE STORY HOUSE
 (FIXTURES BACK TO BACK)

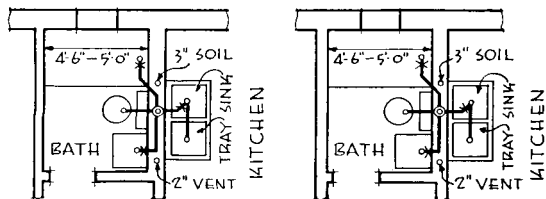
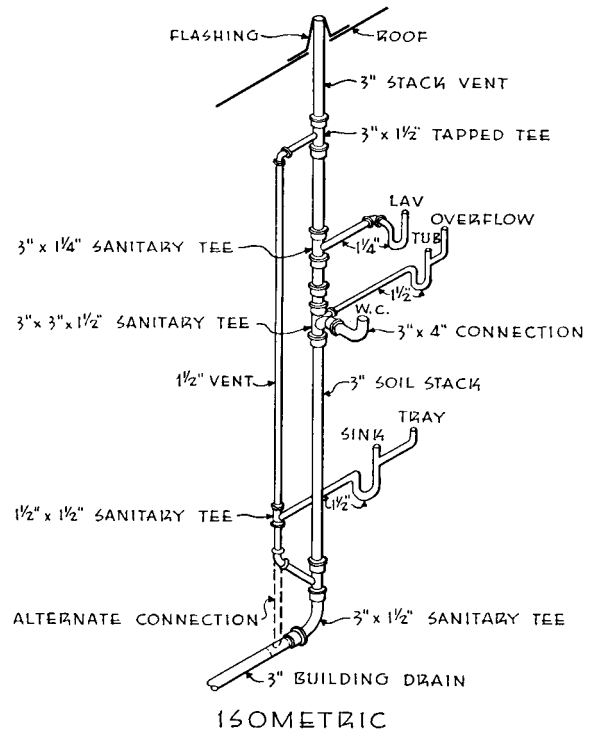
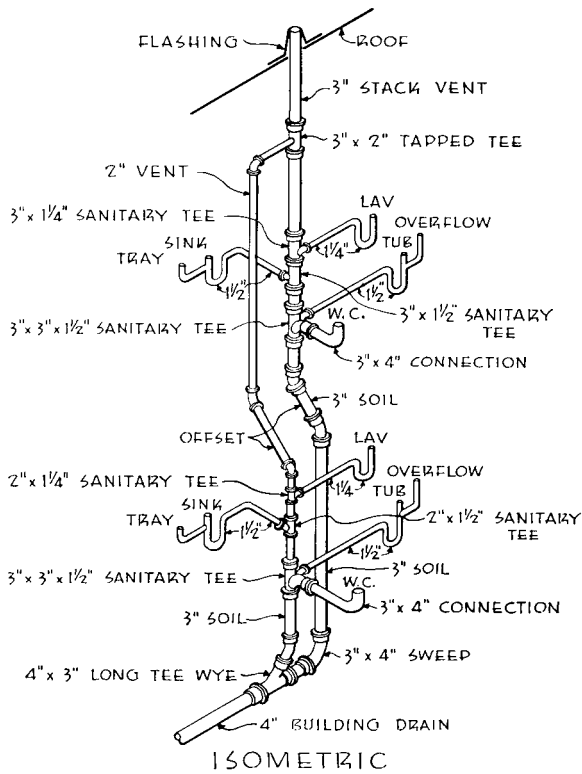

FIRST FLOOR PLAN SECOND FLOOR PLAN
 TWO FLATS (2-STORY)

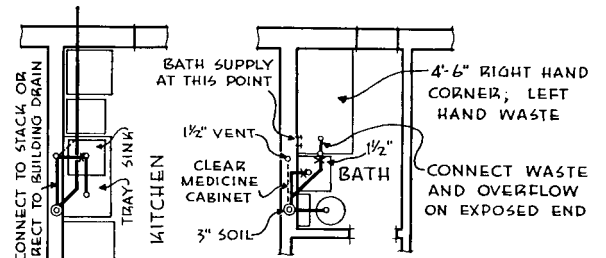

FIRST FLOOR SECOND FLOOR PLAN
 TWO STORY HOUSE

PLUMBING SYSTEMS for DEFENSE and LOW-COST HOUSING

5-VENT PIPING DIAGRAMS and DEFINITIONS

NOVEMBER, 1941

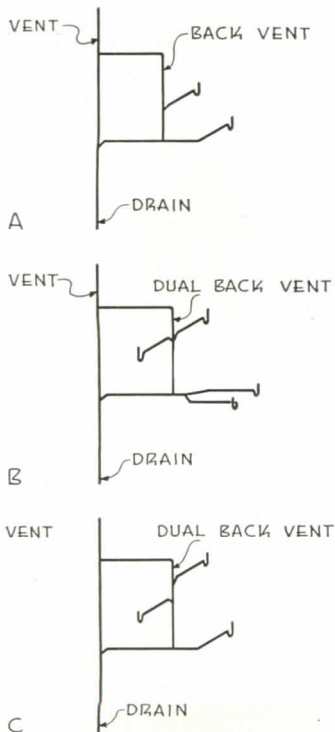
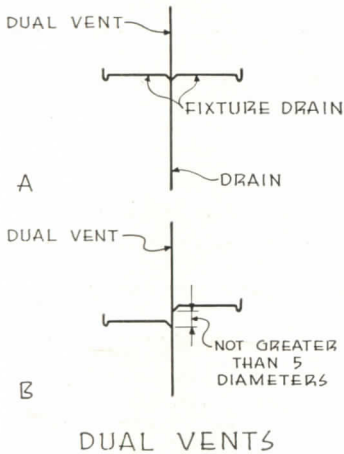
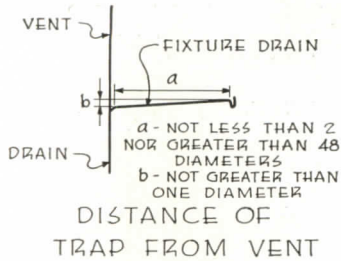

GROUP VENTS FOR LAVATORIES AND BATHTUBS

THESE VENTING STANDARDS, as set up in BMS 66 (see other T-SS in this series) and approved by USHA for defense housing, do not necessarily meet the requirements of the average local plumbing code. Data were compiled by Burton A. Bugbee, Architect.

The seal of every fixture trap has to be protected by a properly installed vent—stack vent, vent stack, back vent, relief vent, dual vent, circuit vent, or loop vent, or combination of two or more forms.

Stack vent. Every soil or waste stack shall be extended vertically as a *stack vent* above roof.

Vent stack is installed with soil or waste stack when branch vents are required in two or more branch intervals. A vent stack may extend independently to open air or may be connected to stack vent above highest fixture.

Distance, Trap to Vent. Each fixture trap, excepting water closets, pedestal urinals, and other fixtures which depend on siphon action, shall have a protecting back vent or relief vent, preferably a continuous-waste-and-vent, located so that total fall in fixture drain from trap weir to vent fitting is not more than 1 pipe diameter, and developed length of drain from trap weir to vent fitting is not less than 2 nor more than 48 pipe diameters (see diagram).

Dual Vent for two fixture traps installed as a vertical continuous-waste-and-vent, or a stack vent in a dual capacity, may be employed under the following conditions, and no additional vents for the traps thus vented are required:

A—When both fixture drains connect with a vertical drain or stack at the same level, and the developed length and total fall of each of the two fixture drains is within the above limits (see diagram).

B—When: (1), the two fixture drains connect with the vertical drain or stack at different levels; (2) difference in level of the two connections is not greater than five times the diameter of the vertical section of drain or stack; (3) diameter of vertical section or stack up to and including the higher connection is not less than that required for the horizontal drain for both fixtures; (4)

cross-section of the higher of the two fixture drains is not greater than one-half that of the vertical drain; and (5) developed length and total fall of each of the two fixture drains is within the above limits (see diagram).

Group Vents. A—A lavatory trap and a bath tub or shower stall trap may be served by a common horizontal branch with a back vent for the lavatory trap, and with no back vent for the bath tub or shower stall trap, provided: 1, vertical section of the lavatory drain is of not less than 1½-in. diameter; 2, drain connects with the tub or shower stall drain in a vertical plane; and 3, developed lengths of both fixture drains are within the limits above (see diagram).

B—Two lavatory traps and two bathtub or shower stall traps may be served by a common horizontal branch with a dual vent for the lavatory traps and with no back vents for bathtub or shower stall traps, provided that: 1, the horizontal branch, except the separate fixture drains, shall be at least 2 in. in diameter; and 2, fixture drains for bathtubs or shower stalls connect as closely as practicable upstream from the vent by means of a drainage wye (see diagram).

C—A lavatory trap, kitchen-sink trap, and a bathtub or shower stall trap may be served by a common horizontal branch as in (A), provided the dual vent for the lavatory and sink traps is installed in accordance with the above (see diagram).

Yoke and Relief Vents: Bathroom groups, each consisting of a water closet, lavatory, and a shower stall or bathtub with or without shower head, may be served by group venting as follows:

Two bathroom groups, or one bathroom group and kitchen sink or kitchen-sink-and-tray combination, may be installed in the highest branch interval of the soil stack or on a vertical yoke-vented branch of not less than 3-in. diameter with no branch vents other than the yoke vent, provided: 1, each fixture drain connects independently to the soil stack or with the water-closet drain (closet bend) in the highest branch interval; and 2, each fixture drain in all except the highest branch interval connects independently with the yoke-vented branch or with the water closet drains (closet bends) within the limits above (see diagrams on preceding page).



**GOLD BOND
HUSHES
WALDORFS'
RUSHES**

THE famous Waldorf Cafeterias need no assistance when it comes to planning meals or running fine restaurants. But when noise stepped in, they turned the problem over to Gold Bond sound control research and service.

Gold Bond is prepared to serve you completely in any way you require. For example, within the past six months, the U. S. Army chose Gold Bond to silence airplane motor test chambers . . . to kill sound in arsenal firing ranges. Every day Gold Bond meets new acoustical problems—and licks them with a complete line of sound control products and a carefully chosen organization of Acoustical Distributors ready to supervise a perfect installation—and guarantee results. Continuous research and dependable service have made National Gypsum Com-

pany the largest exclusive manufacturer of wall and ceiling materials in the world, with 21 modern plants serving the country. Under the Gold Bond name, National offers more than 150 *better* products, sold and serviced by more than 300 trained representatives. Gold Bond products include gypsum wallboard, insulation, plaster, lime, metal lath and acoustical materials. And when you specify Gold Bond exclusively, you get the added protection of having *one* manufacturer responsible for the final result. Refer to Acoustical Section in Sweet's, or write today for standard catalog file containing complete specifications on all types of Gold Bond sound control products. SOUND CONTROL PRODUCTS DIVISION, NATIONAL GYPSUM COMPANY, BUFFALO, NEW YORK.



Architect—H. S. Sack

Acoustical Distributor—Dillaby Fireproofing Company

THE SAVINGS ON THIS GOLD BOND ECONOCOUSTIC JOB were enough to pay for the extra decorative effects that beautify all Waldorf restaurants. Within the past year, 15 of these famous Waldorf restaurants have installed Econocoustic—the smart, decorative tile that lowers noise levels, increases light reflection, and helps insulate.

BUILD BETTER WITH

Gold Bond

Everything - for walls & ceilings

Producing units at:

NEW YORK, N. Y. . . . CLARENCE CENTER, N. Y. . . . AKRON, N. Y. . . . PORTSMOUTH, N. H. . . . NATIONAL CITY, MICH.
FORT DODGE, IA. . . . MEDICINE LODGE, KAN. . . . ROTAN, TEX. . . . SAVANNAH, GA. . . . LUCKEY, O. . . . BELLEFONTE, PA. . . . YORK, PA.
ORANDA, VA. . . . SALTVILLE, VA. . . . NILES, O. . . . MOBILE, ALA. . . . NEWBURGH, N. Y. . . . ALEXANDRIA, IND. . . . DUBUQUE, IA. . . . DOVER, N. J.

Blackout Materials for Industry

BLACKOUT rehearsals as well as the need for insuring against enforced shut-downs of production units at night have brought the necessity for relatively inexpensive blackout materials which may be compactly and conveniently stored without deteriorating. A material of this type is now available to industrial plants which are engaged in the national defense effort, and will also be made available to homes, public buildings and other institutions if the necessity arises. The material consists of two elements: One, a self-laminating blackout sheet in which the adhesive is integral with the material, protected by a removable sheet of glassine covering the adhesive surface. While thus protected the adhesive is said to retain its adherent quality—its “tackiness”—for a long period of time. Furnished in rolls 26 in. wide, each 50-yd. roll is packed in a carton and weighs approximately 10 lbs. As much as 10,000 yds. can be stacked on one skid. Second, supplementing the blackout sheet in use, is a daylight vent operating on the principle of a flat channelled frame and removable panel of light-weight though rigid material, assembled as a complete unit. Likewise furnished with integral, protected adhesive and packed in cartons. Tough, with high tensile strength, the blackout sheet can be cut to proper size. Tests have indicated that the permanence of the thermo-plastic adhesive makes it a protection against flying splinters of glass. Fragments are held in contact even when the pane is cracked into pieces. U. S. Defense Materials Corp., 315 Berry St., Brooklyn, N. Y.

American Ceramic Tiles

DESIGNED and made in America, a most attractive line of ceramic tiles has made its appearance. These tiles, in rich colors and a good variety of floral, abstract and other designs, are washable, impervious to heat and cold, stains and weather. They are suggested as decorative effects for lobbies, terraces, kitchens and baths,

display rooms, swimming pools, bars and soda fountains, fireplaces, pent-houses, show cases, store fronts; or as furniture insets. Standard tiles are 6 by 6 in. Exclusive designs can be produced in quantity. Ceramic Tiles, 34 Walker St., New York City. (See figure 1.)



Figure 1

New Shingles are Self-“Randoming”

STRIP shingles that look like custom-cut roofing are announced for national distribution. The tabs are variegated as to width, length and coloring and given wood-grained textures, to prevent a monotonous appearance. The manufacturer says the tabs are “self-aligning, self-nail-covering, self-joint-protecting and self-randoming,” and claims economy and excellent weather protection. United States Gypsum Company, Chicago, Ill. (See figure 2.)

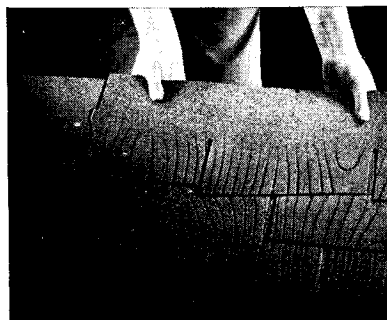

Figure 2

House of Ideas

OPEN for a month of public inspection during October was a “House of Ideas” in Bridgeport, Conn. Into a traditional New England architectural envelope were fitted such ideas as the following: circulating heatilator in the fireplace for use when fire is lighted; fluorescent lighting strips built in over windows in living and dining rooms to show drapes to advantage; shower stall in powder room; recessed fluorescent lighting over bed head; built-in shelves, drawers and racks in closets; two basins in bathroom, the smaller with shaving mirror; lighted kitchen working surface of basket weave impregnated in plastic; silent mercury non-click switches; circuit breakers to eliminate fuses; loudspeaking system at front and rear doors; package receiver with light in kitchen to signal when a package is delivered. General Electric Company, Bridgeport, Conn.

Acoustical Units

FOR sound control in broadcasting rooms, theaters, auditoriums, hospitals, restaurants, offices comes a lightweight acoustical material composed basically of Diatomaceous earth, of low thermal conductivity, with a finely knitted surface. The insulation, in travertine or white, with smooth or fissured surface, is applied to solid backing, may be sanded to obtain a new surface, does not contract or expand, is fire-resistant. Stock thicknesses $\frac{1}{2}$, $\frac{3}{4}$, $\frac{7}{8}$, 1 in. Sizes 12 by 12, 6 by 12, 18 by 18, 24 by 24 in. Incombustible. R. Guastavino Company, 500 Fifth Ave., New York.

Adjustable Bath Tub Hangers

ALL-metal hangers provide a means of holding a built-in bath tub without possibility of settling. The anchors are attached to left or right side studding by two lag screws, with an adjusting nut above the rim of the tub for raising or lowering. May be used on brick or wood walls. Hollaender Hanger Co., 1833 Sycamore St., Cincinnati, Ohio.

(continued on page 106)

[[The attractive Nairn Linoleum walls and floor make this living-room in the boys' cottage at the Southbury Training School a very pleasant place.]]
 [[The outstanding durability of Nairn Linoleum will keep the room in good condition for years, in spite of the "wear and tear" of a houseful of boys.]]



Here's a specification that meets every "endurance" test for public buildings

—and provides color and beauty, too!



Exterior of the Southbury Training School of the Connecticut State Department of Public Works, Southbury, Connecticut.

NAIRN LINOLEUM is the architect's answer for the floors and walls of public buildings, where long-lived, hard-wearing materials are "musts."

Exceptionally durable against heavy daily foot traffic, Nairn floors can take it for years with hardly a sign of wear. Nairn walls are practically *permanent*. Under normal conditions they will last as long as the building itself!

But Nairn Linoleum does more than wear well. It is sound-deadening, easy on the feet, and easy to maintain. Nairn floors need only regular clean-

ing and waxing. A damp cloth removes dust or spatters from Nairn walls.

In addition to its sturdiness, Nairn Linoleum brings new beauty. Obtainable in a wide variety of colors and patterns, it makes possible charming decorative effects through the use of contrasting insets and borders.

Add moderate first cost and negligible upkeep to the other Nairn features and you have the perfect public building specification for both floors and walls. When installed by

Authorized Contractors, Nairn Linoleum is fully guaranteed.

CONGOLEUM-NAIRN INC., KEARNY, N. J.



ARCHITECTURE

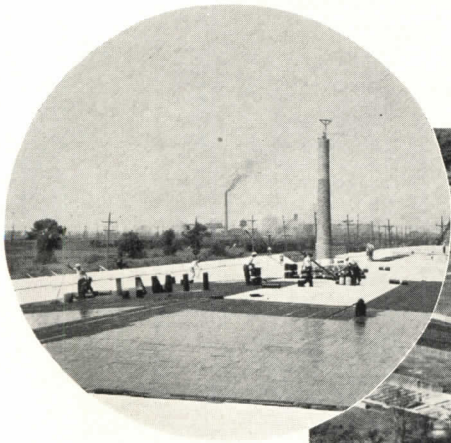

Circle, Chicago Architectural Photo. Co., airview, courtesy United Engineers and Constructors, Inc.

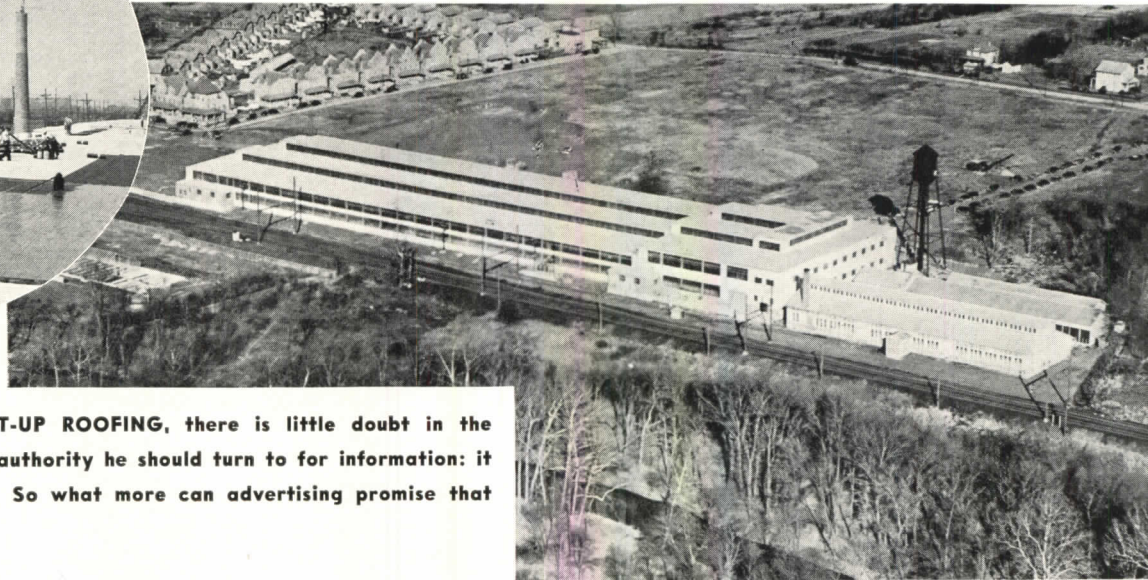

WHEN IT COMES TO BUILT-UP ROOFING, there is little doubt in the architect's mind as to what authority he should turn to for information: it is always the manufacturer. So what more can advertising promise that is not already evident?

The answer may be service—service in the shape of informative copy that gives the architect a better idea of procedure, a better picture of the scope of built-up roofing application.

As many as 30 different built-up roofing specifications have been established by a single manufacturer. To the average architect, who may not have occasion to employ built-up roofing very often, this might well present a confusing picture.

Doesn't it seem reasonable to suggest that advertising is the ideal means of clearing up this picture; of showing the architect the necessity for this wide selection?

Advertising could discuss, for example, those factors which affect the selection of any built-up roof—climate, pitch of roof, deck construction and cost—and thereby show the advantage of so wide a choice. It might point out the peculiarities of various types of deck construction and show why such things as the resinous condition of wood deck, or moisture in gypsum, must be taken into consideration. There are many related subjects that would make interesting copy for the technical reader.

In the final analysis, few roofs fail—but when they do it is rarely due to flaws in material or poor workmanship. It is due, more often, to either a mistake in selection or a change in conditions. Give the architect a better understanding of built-up roofing application; a procedure on which to base selection, and greater satisfaction, greater sales, will result.

—RONALD ALLWORK

Last Month's Question Which Readers Answer on Facing Page

As a practicing architect, what questions occur to you regarding built-up roofing which you feel could be answered in manufacturers' advertisements?

MEETS ADVERTISING

ARCHITECTS GIVE THEIR VIEWS ON BUILT-UP ROOFING ADS

FRANKLIN O. ADAMS, FAIA

WHAT usually inspires an architect to look at advertisements of building materials and equipment?

He usually doesn't do it with the object of finding any specific item, because it is much handier to go to Sweet's Catalogue or the AIA files. I believe, in most cases, he is looking for news of interest, either announcing new materials or new methods of using old materials. If the advertising has real news to tell, it should be properly headlined, followed by a brief but interesting descriptive text.

If the advertiser has nothing new to offer, he must aim his advertising at the younger practitioners, to whom many products may still be news, or to the older architect who must be kept reminded of the advertiser's products.

CLARENCE A. CAULKINS, JR., AIA

HERE are some questions which occur to me:

1. How many years can the roofing be expected to wear?
2. What is the composition of the cap sheets, etc.?
3. What about underwriters' labels, quality of asphalt, pitch and felts?
4. What service does the manufacturer offer me?

LEO A. DALY, AIA

I THINK you will find that the biggest problem of a built-up roof is the matter of flashings, and the advertisers could best serve the architects by ad-

vising them of the best methods of flashing at the different surfaces which the roof abuts, such as walls and ventilators. I refer to flat roofs at the edge of decks.

ROBERT FINNEY FERGUSON, AIA

I SHOULD LIKE to see set forth in roofing advertisements the various types of materials, the advantages of each, the function that each material performs. Also the common faults of application of the roofing, flashing, etc. So much for the public.

For the architect, advertising should include the types, weights and grades of each, new innovations in applying, etc.

We would advocate a closer check-up of the manufacturers' distributors, or their applicators. We find that in areas where built-up roofing is under a stigma this is wholly due to local roofers who may be unscrupulous, incompetent or negligent.

The company which sets out to clean up this phase of the game and

then uses plain basic facts pertaining to built-up roofing in their advertising, making the protection of the user their paramount attempt—that roofing company is insured a much larger demand for his product.

RUSSELL STACEY JOHNSTON, AIA

MANUFACTURERS should state more clearly that certain types of roofs are fireproof to a certain extent; also, clearer comparison of the different types manufactured should be indicated in their catalogues.

PHILIP CHARLES BETTENBURG, AIA

ADVERTISING of roofing materials might well describe the proper installation of insulation as a base for various types of roofing. Also the best method of installing over gypsum, monolithic or precast roof slabs. There is a variance in manufacturers' opinions as to nailing or priming and mopping directly to slab. The same is true of the insulation under this roof.

NEXT MONTH'S QUESTION

AS A PRACTICING ARCHITECT, WHAT SUGGESTIONS COULD YOU OFFER TO THE MANUFACTURER OF HEATING OR AIR CONDITIONING EQUIPMENT REGARDING HIS ADVERTISING?

SEND US YOUR IDEAS FOR PUBLICATION IN DECEMBER!
FORMS CLOSE NOVEMBER 20.

RU-BER-OID BUILT-UP ROOFS protect another housing project

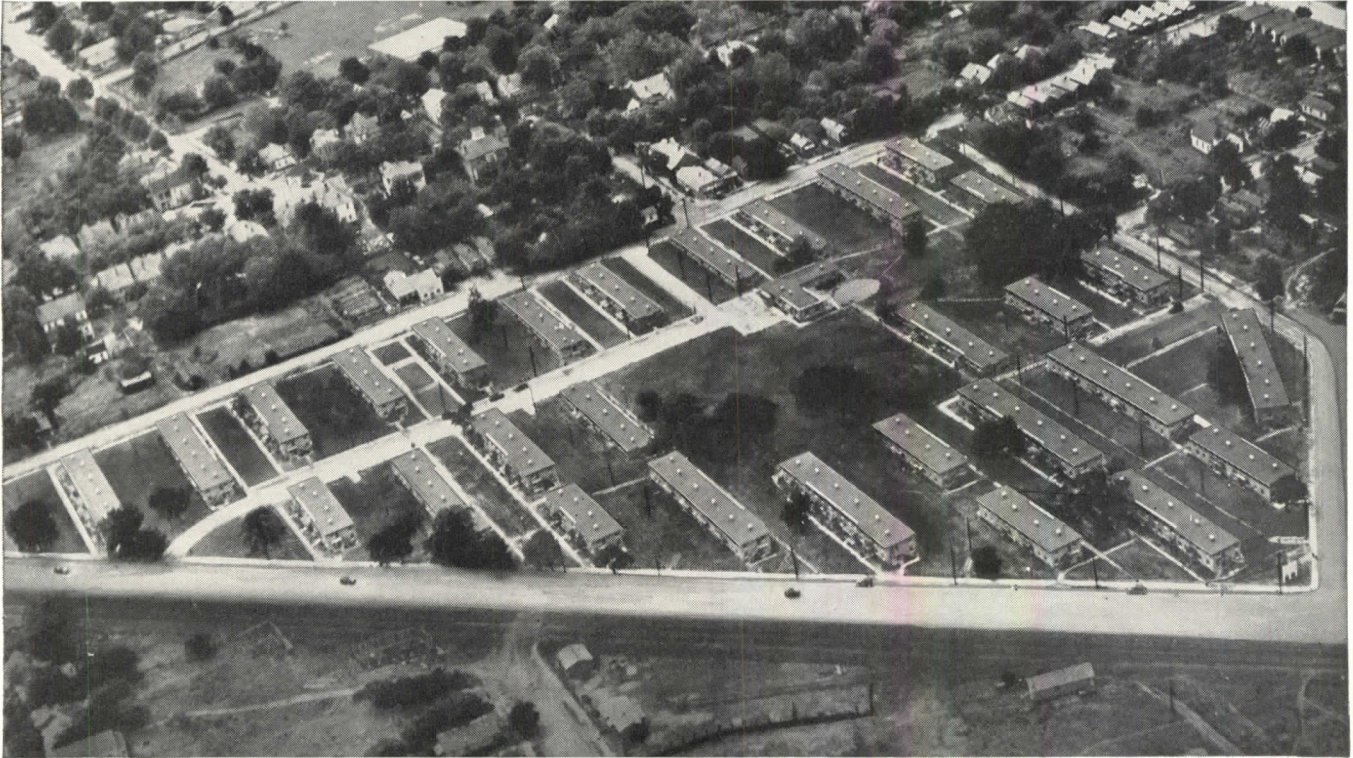

Gilbert Manor Housing Project, Augusta, Ga. Protected with 129,300 sq. ft. Ruberoid Coal Tar Pitch and Asbestos Tarred Felt Built-up Roofing. Owner, Augusta Housing Authority. *Architect*, Merry & Parsons. *General Contractor*, Claussen-Lawrence Construction Co. *Roofing Contractor*, Augusta Roofing & Metal Works.

Whether its North, East, South or West—regardless of climatic conditions—more and more RU-BER-OID Built-up Roofs are being specified. There are many reasons for this trend. Foremost is the completeness of Ruberoid's line of built-up roofing.

Ruberoid makes not one but all three major types of built-up roofing: (1) Asbestos, (2) Asphalt and (3) Coal Tar Pitch and Felt, and in a wide variety of weights and finishes. Architects can choose not only the type but the specification that best adapts itself for each job. Roofs can be custom-built to climatic conditions, the anticipated life of the building, fire hazards, fumes,

etc. — and when applied by approved roofing contractors, may be bonded for 10, 15 and 20 years for both materials and workmanship.

When you have a job on the boards where roofing counsel is desired, call in a Ruberoid engineer. His services are free. Because the Ruberoid line is complete, his recommendations are unbiased. For popular specifications, consult Sweet's. For complete specifications, write us on your letterhead please. Address The Ruberoid Co., 500 Fifth Avenue, New York, N. Y. Department AR-11.



RU-BER-OID
ROOFING AND BUILDING PRODUCTS

