

WHAT PRIORITIES MEAN TO BUILDING

A critical study of the several puzzling questions about priorities and their impact on building. It discloses: 1. That building prospects are not as dark as early, confused reports might indicate. 2. That private as well as public defense building projects are to get preferential ratings for securing materials. 3. That while non-defense building will be left to shift for itself, it is not banned. 4. Defense building projects of many types will swell construction volume. 5. Priority orders on metals for manufacture promise shifts and strains, challenging architects and manufacturers alike to find and use suitable substitutes and to find new ways to conserve essential materials in all types of building.

By **ROGER WADE SHERMAN, AIA**, Managing Editor of **ARCHITECTURAL RECORD**

WHEN, HOW AND WHERE the metals priorities will affect building is a series of puzzles which cannot be definitely solved at this moment, or probably any other moment. Statements, rumors and guesses, currently reaching flood proportions, are not to be taken at face value. But while many of the problems can only be resolved in the future, a critical analysis of the situation does clear up some vital points.

The priorities situation on basic materials for manufacture may be expected to become serious, possibly soon, but the prospects for building are by no means as dark as the casual reader of newspapers might have been led to suppose. "Business as usual" cannot be expected to continue indefinitely, but building of many types must play a large part in the national defense effort, and "building as unusual" should go forward in quite substantial volume.

This first major report (*ARCHITECTURAL RECORD* led off with a preliminary statement (AR 2/41, p. 16) has for its purpose a straightforward statement of facts now available, and a presentation of the probabilities as they currently line up.

The major points, at this early stage of priorities ruling, are:

1. Priorities will *help* building at the same time they hinder it; building in designated defense areas will be directly aided by the priorities system.
2. No formal restrictions as such on non-defense building are planned at present—critical basic materials, not building projects, are the primary subjects of priorities rulings. Defense projects (destroyers or houses) will receive preferential treatment in the allotment of the materials, but other projects have not been specifically restricted.
3. Priority systems remembered from World War I are obsolete today and should be eliminated.
4. New specifying and buying techniques will surely develop.
5. The demand for building of many types, coming from increased incomes generally, challenges the ingenuity of architects in the use of new or substitute materials to keep building active.
6. Priorities affect only a few basic building materials, principally metals; there are no general shortages of most materials or products, or of labor.

Private "non-defense" building is not banned—it is merely left to find its own materials

Contrary to the tone of some recent newspaper stories, Washington officials have not expressed any present intention of putting specific restrictions on any type of building in any locality. Non-defense building is not banned—it is merely left to shift for itself. It is not impossible, or unpatriotic, to proceed with present building plans whether or not they are related to defense. Misunderstandings on this score seem to come from thinking in terms of the priority system of World War I. The present system is entirely different (see comments of Thomas S. Holden, page 38). What will happen is that specific basic materials (and later fabricated products) will be subject to priorities rulings, to assure adequate supplies for defense industries and defense housing. Any remaining stocks may be used for any type of building project.

Projects left to shift for themselves—or find practical substitute materials—will be those which cannot secure the benefits of preferential rulings in their favor. An expensive private residence, even in a defense area, is an obvious example, or any

WHAT PRIORITIES MEAN TO BUILDING (continued)

type of structure considered non-essential to defense. Quite aside from material shortages, luxury type building would be expected to be somewhat curtailed by the developing tax situation.

Non-defense areas may expect to suffer somewhat, perhaps seriously. Even here the prospect is far from hopeless, for it is a logical assumption that defense areas will be increased both in number and extent, as new defense orders go out and as new pressure is put on industry to farm out sub-contracts. In the past few weeks, 30 new defense areas have been added to an already long list. Also, Leon Henderson's Office of Price Administration and Civilian Supply (OPACS) is intended to ease the strains of the defense program on the civilian economy, and it might later find means to sustain activity in an industry as generally important as building.

Priorities assistance to be extended to defense building projects, private and public

In an important recent statement E. R. Stettinius, Jr., Director of Priorities for OPM, and Charles F. Palmer, Coordinator of Defense

Housing, jointly announced "a broad program providing priority aid for defense housing projects," the purpose of which is to "assure a steady flow of necessary building materials to the projects deemed essential to the national defense program." Priority assistance may be given either to a publicly financed defense housing project or to private defense projects within a designated defense area. Actually private building will receive the most benefit, since private enterprise is expected to supply the bulk of defense housing.

Under the procedure announced, a preference rating will be given either to a publicly financed defense housing project, or to an area. These project or area ratings are to be extended to *applicants* by local representatives yet to be designated by the Coordinator. It is not yet clear in which government agency the representatives will function. Possibly it will be FHA. Meanwhile contact on priorities questions should be with the district manager of OPM, at the Federal Reserve Bank in each Federal Reserve District.

As to privately financed defense housing, to be handled under "area ratings," the announcement specifies that "the housing will be suitable

for, and reasonable preference in occupancy will be given to, workers engaged in the designated defense industries; that the intended sales price is \$6,000 or less or the intended shelter rental is \$50 per month or less, and that the housing is, in general, necessary in connection with defense housing needs." Exceptions may be made for other residential construction if the designated authorities consider it essential to defense needs. The priorities procedure will definitely apply to rehabilitation of existing structures.

To further clarify the procedure, the Housing Coordinator is to supply OPM with a list of public housing projects for which priorities aid is recommended, a list of areas in which a present or impending housing shortage threatens defense activity, and a formal definition of defense housing. Being prepared also is a Defense Housing Critical List of building materials for which preference ratings seem necessary. A definite effort is being made to exclude many critical metals, for which substitute materials are being sought. Even though an item necessary for a defense housing development is not on the critical list, priorities aid may be secured to speed deliveries,

THE PRIORITY SITUATION AS I SEE IT

The following are excerpts from a current statement by THOMAS S. HOLDEN, President of F. W. Dodge Corporation and Editorial Director of ARCHITECTURAL RECORD, based on several personal interviews and investigations in Washington and elsewhere

MUCH CONFUSION and misunderstanding exist with regard to priority rulings of the Office of Production Management and with respect to their impact on private building. To clear up this confusion, it is essential to eliminate any preconceived ideas about priorities derived from World War experience. A recent official OPM statement said:

"Forget all you have heard or know about the World War Priority System. To understand where we are in the present development of priorities and, in fact, to understand the system at all, this might well be your first rule. Much of the confusion about priorities comes from trying to tie up some phase of the present system with the priority plan as remembered from World War days."

Recent announcement of a system of priorities favoring defense housing caused a number of newspapers to report this new ruling in terms of "restrictions" on private building or "drastic regulation" of private building. Such misinterpretations of the intent of the recent priority order probably

arose from recollection of the order (Circular 21) issued on September 3, 1918, requiring that permits be secured from the World War Priorities Board for all construction projects, except those under Government contracts cleared by the board, repairs not exceeding \$2,500, construction directly connected with mines producing coal or metals, and highway improvements approved by the United States Highways Council. Among the principal reasons for that drastic regulation of 1918 were the need for conserving lumber and transportation, neither of which has reached a critical stage at this time. Recent personal conferences with a number of Washington officials have not disclosed any present intention, on the part of any Government executive or agency responsible for defense activities, of forbidding any particular class of construction project.

In fact, priorities are being administered as preference ratings assuring delivery of necessary critical materials for defense purposes in the order of their importance to defense production and in advance of delivery of such materials for

through application to the local priorities representative.

Defense program to swell volume of residential and other types of building

The actual purpose of the preference ratings for defense housing is to increase the volume of this class of construction, both public and private. On many occasions Mr. Palmer has set the need at 625,000 family dwelling units for the current fiscal year (July 1941 through June 1942). This compares with an estimated 500,000 in the past fiscal year. Of the 625,000 units Mr. Palmer expects 500,000 will be built by private enterprise, 125,000 by government agencies. Most, but not all, of the desired total units are considered to be defense housing.

Thus the Coordinator is asking for a 25 per cent increase in residential construction. There will also be a continued heavy program of industrial building. The PWA, with a recent appropriation of \$150 million, will continue supplying community facilities in defense areas. And priority assistance will be extended to the modernization of existing buildings in defense areas. Thus while certain types of construction may be

expected to suffer somewhat, the prospect is good for large construction program in the months ahead.

Even for non-defense building, the prospect is not entirely discouraging. New housing for defense generates a need for other types of construction. Evidence of this is found in the new \$150 million PWA program of extending community facilities, which involves several types of buildings, including schools, waterworks, recreational buildings and hospitals. Aside from the possibility of additional PWA appropriations to widen the scope of defense public works, it may be expected that needs for commercial and service buildings will develop. While such buildings have as yet had no recognition so far as priorities are concerned in the defense program, it is logical that they should when their need is demonstrated. Moreover, the number of defense areas has been growing, and should be increased further by the effort to spread defense orders.

Shortages are mainly in metals; most building materials are available

The expected shortage of materials is virtually limited to the metals. Non-metallic building materials—

lumber, cement, masonry materials, glass, etc., (except rubber and cork) are not in trouble. There may be local shortages of some, but over the country no general stringencies are now expected.

For the critical materials, a recent summary of priorities action shows two forms of priority control:

“Industry-wide mandatory control” is being maintained on 15 materials and classes of materials:

- Aluminum
- Magnesium
- Nickel
- Nickel-steel
- Ferro-tungsten
- Tungsten high speed steel
- Machine tools
- Synthetic rubber
- Copper
- Cork
- Borax
- Polyvinyl chloride
- Zinc
- Rubber
- Chromium

Of these, copper and zinc are probably those most used in building products. In neither case is the full available supply preempted for defense, and increased production of both can be expected in the future.

A “mild form of inventory control” is exercised over 14 metals and classes of metals:

civilian needs. Up to the present time, priorities relate only to specific critical raw materials and manufactured products. The project itself (whether a destroyer or a house) is not the subject of a priority rating, but its purpose in the general scheme of defense determines whether a priority rating (meaning a preferential position in the list of those entitled to receive critical materials) shall be given.

Thus, the purpose of priorities is preferred treatment for the first need—defense—and not restriction of non-defense activities. Only in cases where the total supply of a critical material or product is preempted by priorities for defense needs does the priority ruling, in fact if not in principle, become a restriction of non-defense activities. In the case of many critical materials, preferential defense needs will tend to curtail but not eliminate supplies available for non-defense uses; in such cases, where it is necessary OPACS (Office of Price Administration and Civilian Supply, under Mr. Leon Henderson) will recommend allocations of residual supplies over and above defense needs to specific civilian uses. To date, OPACS has taken no important action along these lines with reference to construction materials.

When questioned recently, OPM officials were reluctant to make any statements as to the amounts of critical materials available for civilian uses, on the ground that the program of defense requirements changes very frequently, thus mak-

ing any predictions as to civilian supply very hazardous. The U. S. Department of Commerce reports that at the end of May 1941 inventories in the hands of durable goods manufacturers amounted to \$1,000,000,000 more than in May 1940 and represent an all-time high. At the present time, there are no comprehensive data available on inventories of building materials in the hands of distributors and retail supply houses. Architects and builders concerned with non-defense projects should canvass all suppliers in their local markets in order to ascertain the possibility of deliveries of essential materials that may be on the critical list.

It would be foolish to minimize the difficulties of planning and executing non-defense construction projects under the priorities system, which will necessarily require changing rulings from time to time. It would be equally foolish to minimize the difficulties that will be encountered by producers and suppliers of materials. But it is equally unrealistic to assume at this time that non-defense construction will be impossible to execute. The demand and supply status of many of the critical materials will vary from time to time, economies in their use can be effected in construction design, and in many cases substitute materials can be used. As the situation develops, a clear objective appraisal of conditions will be necessary, plus a critical attitude towards rumors, incomplete newspaper reports and sensational headlines.

WHAT PRIORITIES MEAN TO BUILDING (continued)

Antimony
Cadmium
Cobalt
Ferrous alloys, all types
Iridium
Iron and steel products, including rolled, drawn, forgings, castings and pig iron
Lead
Manganese or Spiegeleisen
Mercury
Molybdenum
Nonferrous alloys, all types
Tin
Vanadium
Secondary material, or scrap

Iron and steel, most important to building, are in a special class, subject to inventory control, and to a special steel order. Information believed by RECORD editors to be reliable indicates that any near-term shortages of steel for construction are very likely not to extend over more than three or four months. This is borne out by a recent statement by Walter S. Tower, president of the American Iron and Steel Institute (in the New York *Herald-Tribune*): "Available facts justify the belief that, both in this year and in 1942, there will be fully 67,000,000 tons of steel-making capacity which can be used for domestic and civilian consumption and for whatever exports may seem desirable to countries other than Great Britain and Canada."

New or substitute products promise to ease the strain of materials conservation

It may be expected that sooner or later the metal priorities will prove serious in the manufacture and distribution of certain building products. How long manufacturers can continue normal production, or how soon the metals priorities may be relaxed, there is simply no way of knowing. The true situation is that nobody really knows the demand for metals in the months ahead. It has been said that, after facing increased demands in the past, the Government is now "asking for plenty." Still no one can say now that its demands are excessive, or that the situation will be relaxed later. As to finished building materials, however, the indicated present procedure is to go ahead as before, as long as supplies are available.

As metal shortages become serious

American ingenuity is relied upon to come to the rescue with substitute materials and parts, and with ideas to conserve basic things that cannot be replaced. Already manufacturing companies have their research staffs buzzing with ideas for substitute materials and parts in the effort to maintain normal production. And other manufacturers, spurred by the defense activity, are rushing production facilities for entirely new building materials. In a few instances plants are getting into production.

Washington housing agencies have been at work for some time on recommendations for substitutes in building. USHA is issuing a lengthy compilation of substitutes for its type of project. Other recommendations will come shortly from OPM and the Division of Defense Housing Coordination.

A considerable list of examples could already be given. Metal gutters and downspouts can be replaced with wooden ones. Asbestos can be used for the same purpose, or for piping. Cement and glass offer particularly good possibilities. One electric toaster manufacturer, for example, is bringing out a glass toaster, pointing out that the housewife can watch the bread as it toasts, and get just the desired brown. Glass fabric can be used for electrical insulation. One inventor is even suggesting the replacement of aluminum ice-cube trays with little wire baskets making individual ice cubes in paper cups.

Plastics have had especial mention as offering endless possibilities for substitute parts, and undoubtedly much will be done with them. However, certain of the basic materials for plastics are already seriously short; plastic industries may have their own priority troubles.

New specifying and buying techniques challenging the ingenuity of architects

Architects and engineers will not miss the challenge in it all. There is first the challenge to keep building as near as possible to "business as usual." The already active demand for buildings of all types will be heightened not only by defense building needs but also by increased business activity and purchasing power.

Construction will be vital to the maintenance of local business and employment in non-defense areas. The success of substitute materials and parts depends fully as much on designers as on producers.

Also obvious is the need for conservation of essential materials that cannot be replaced. And this is almost entirely a matter of design—the layout of a plumbing system, an electrical wiring diagram, design of a heating plant. Use of the highest recognized stresses for structural and reinforcing steel, as yet not adopted in many building codes, offers another possibility for conservation.

It is, of course, anybody's guess as to how long such conservation will be acutely necessary or to what lengths it may be needful to go in order to accomplish the objective behind the priorities situation. In any event it is reasonable to expect that emergency requirements will force a relaxation of many building code restrictions. One indication of what changes may be in store is contained in the new Plumbing Code recently completed by a Department of Commerce sub-committee. As other similar revisions to basic codes are developed architects and engineers must inevitably take intensified interest in technicalities of building products and construction processes. It is clear that gradually new specifying and buying techniques will develop which will be vital to building progress; and closer liaison between designers, manufacturers and distributors will be in order.

A point not to be missed is that the professional services of architects and engineers may be expected to be in increased demand. As the new or substitute materials come into use it will require informed technicians to get building projects completed, and capable designers to use the new things properly. Professional designers will be drawn into many new phases of the whole defense program, and will be essential to its progress.

All in all, the present picture of priorities is not a discouraging one. There will be shifts and strains, but "building as unusual" should be active. And there should be plenty of scope for the talents of architects and engineers.



St. Thomas

HOME FOR DEPENDENT CHILDREN

STAYTON NUNN, MILTON MCGINTY, Architects

THE NEW PLANT for the DePelchin Faith Home in Houston, Texas incorporates the experience of a private relief organization in caring for neglected and dependent children over a period of several decades. Although not an "orphanage"—since relatively few of the children are actually without parents—the layout and design of the new DePelchin home sets important standards for this type of institutional work. The management is convinced that children who are deprived of normal home life are best cared for when boarded in foster homes under supervision of a central staff, rather than in a central institution. Some 580 of the Home's children are now being handled in this fashion. But experience has indicated that there is always a certain portion which—for one reason or another*—must be cared for in the central establishment. It is for these children—currently about 125—that the new home is designed; in addition it serves as the central office for administration, inspection and case work.

The central problem was thus to create a living environment for the children as nearly like normal home life, and as free from the "institutional," as possible. It is interesting in this connection that all children attend regular public schools in the neighborhood, are allowed visitors at any time, may visit their parents freely, etc. Dissatisfaction with the limitations and disadvantages of large dormitory buildings—such as had been previously used—led to the adoption of a "decentralized" plan with a series of small cottage dormitories set in the midst of adequate grounds and loosely connected to central units (see next page).

*New children just entering the organization's care; children under special observation because of mental, physical or behavior problems; emergency cases; sick children; short time cases; those found to benefit more from being with larger groups than from boarding in foster homes.

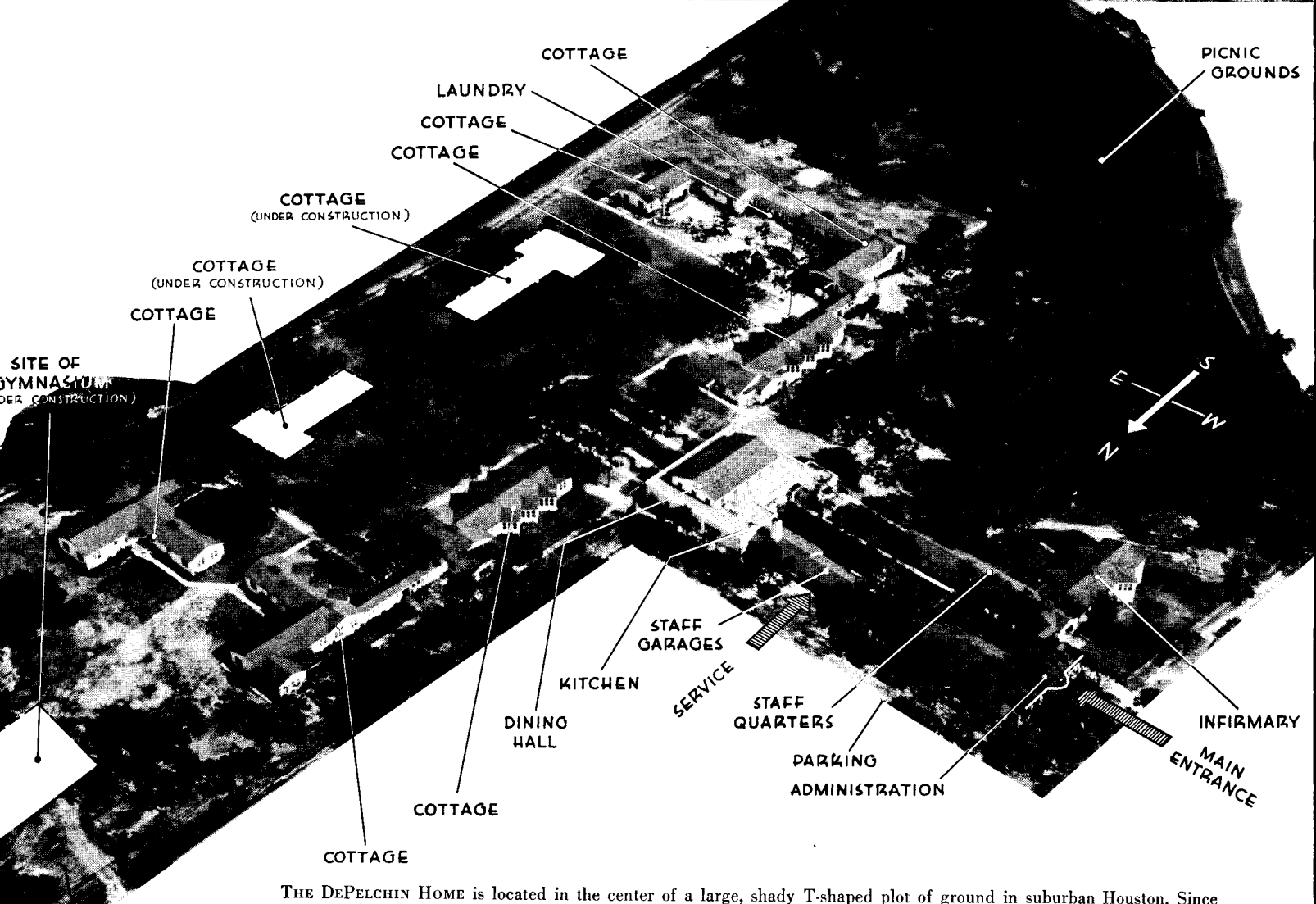

THE DEPELCHIN HOME is located in the center of a large, shady T-shaped plot of ground in suburban Houston. Since arterial highways define the south and east boundaries, the location of the central buildings on dead-end streets (above) removes the project's "center of gravity" as far as possible from heavy traffic.

The general orientation of the cottages, with their sawtooth bays, is designed to capitalize on prevailing breezes during a long summer season; covered passageways make communication between buildings easier in rainy weather. The planning and execution of the grounds are noteworthy for their simplicity: except for small landscaped areas immediately surrounding the main buildings, the entire grounds are free of "keep off the grass" signs so that children may play wherever they wish. The wooded ravine along the north boundary is developed as a picnic ground, with open air fireplaces, tables and benches.

Construction of all the buildings is uniform: Foundations and floors are of reinforced concrete; exterior walls of hollow tile, stuccoed; interior partitions are wood framed with plaster on metal lath; ceilings and roofs are wood-framed, ceilings being finished in gypsum board; low pitched roofs are felt and bitumen topped with clay shingle tile. Each building has its own gas-fired forced air heating system.

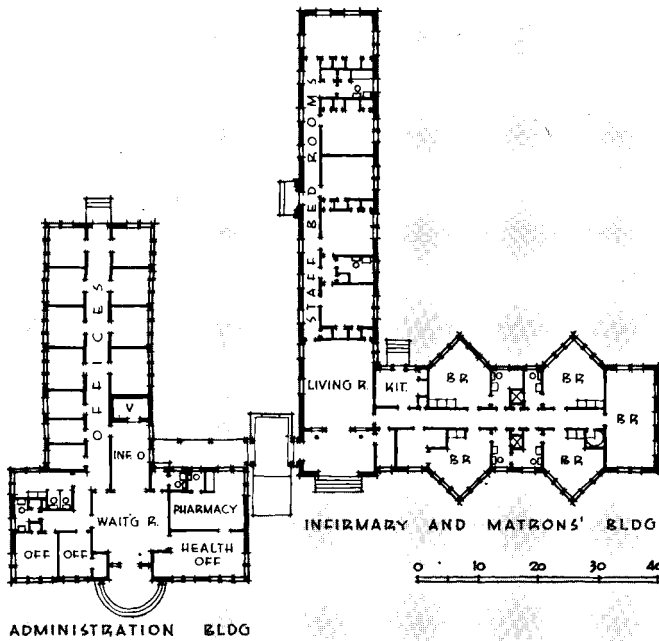

ADMINISTRATION AND INFIRMARY

THE ADMINISTRATION BUILDING establishes the architectural character of the entire plant—simple, low buildings, well fenestrated and domestic in scale. Through this building—situated at the main entrance and flanked by parking area and service drive—pass all children admitted and discharged. Here are located offices for the entire staff, those on visiting duty included. Behind the offices, but connected by a covered porch, are staff garages. (See plan, page 45.) Located in this unit also are health office and pharmacy; these connect by covered passage with the unit housing infirmary and staff residential quarters. (The Home handles all illnesses not requiring hospitalization.)

Photos by St. Thomas



COTTAGE DORMITORIES

EXPERIENCE INDICATED that 25 children was the maximum that one cottage mother and one maid could comfortably handle, while 15 children was the economic minimum. Hence the cottages, whose basic design is identical, are designed to house from 18 to 24 children. Each cottage includes: a large living room for play during bad weather or after supper; a smaller room for visitors or for study; a small kitchen for Sunday night suppers, birthday parties, etc.; bedroom and bath for matron; dormitories and wash rooms; utility room for cleaning supplies.

In line with the attempt to recreate a homelike atmosphere, the children are not segregated by age or sex (except as regards sleeping); brothers and sisters live in the same cottage. The furniture is of standardized design and the children in each room are allowed to arrange it as they choose. Each child has a built-in wardrobe.

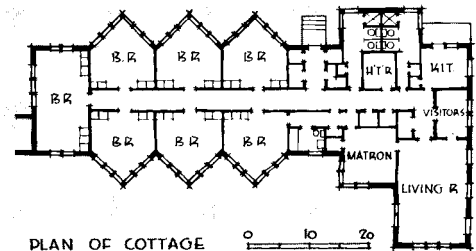

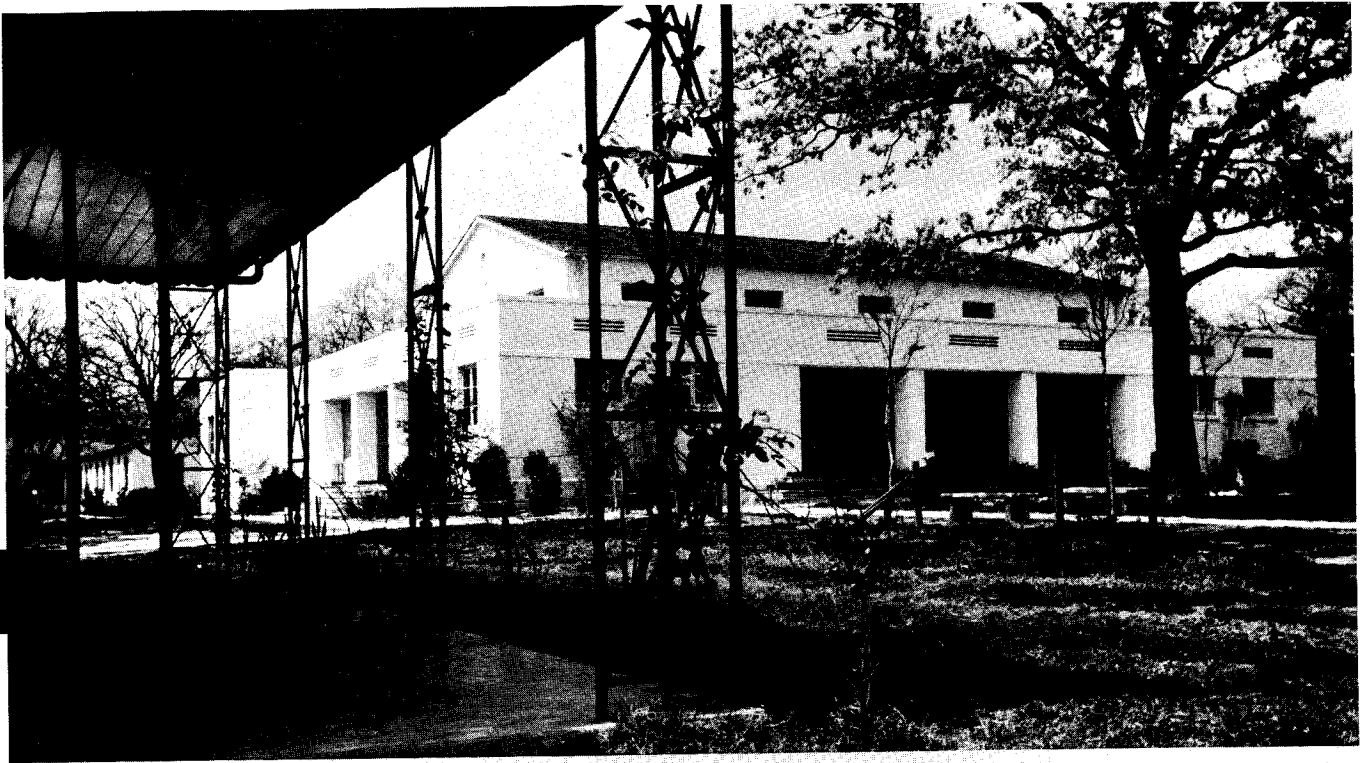

DINING HALL

THIS BUILDING not only includes provisions for feeding upward of 125 children and staff members, but serves also upon occasion as an assembly hall—the staff dining room serving as a stage. Note that the deep covered porch overlooking the central court is flanked on either side by lavatories where children may wash up before eating.

The well equipped pantry and kitchen in one wing open on to the service drive (see plan below); the other wing is occupied by a sewing room and closets for repair and storage of the children's clothes.

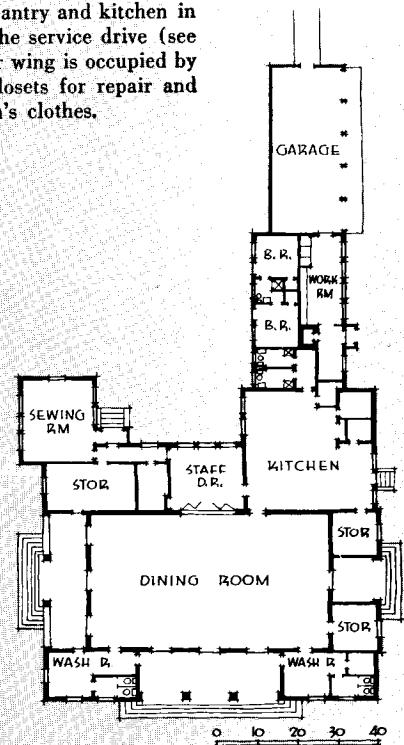

MOVIE THEATER

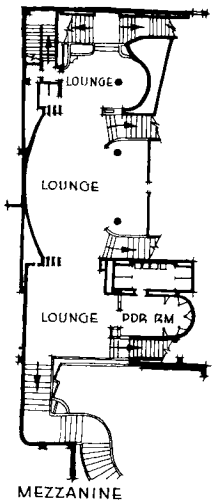
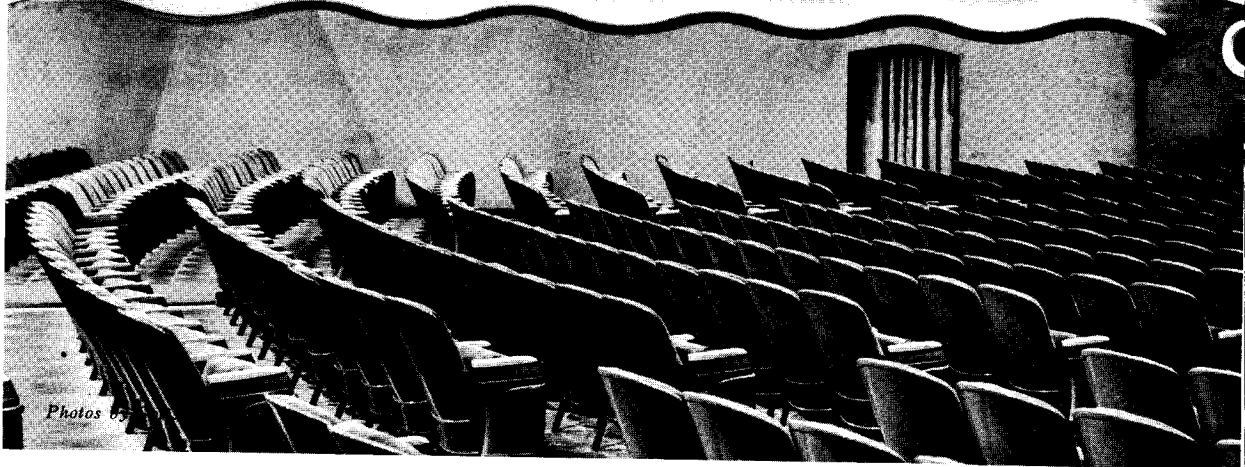

MEZZANINE

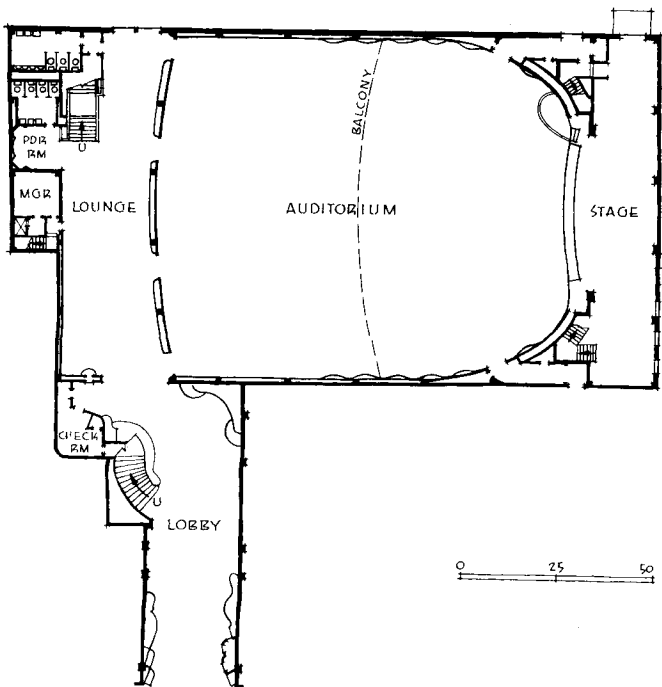

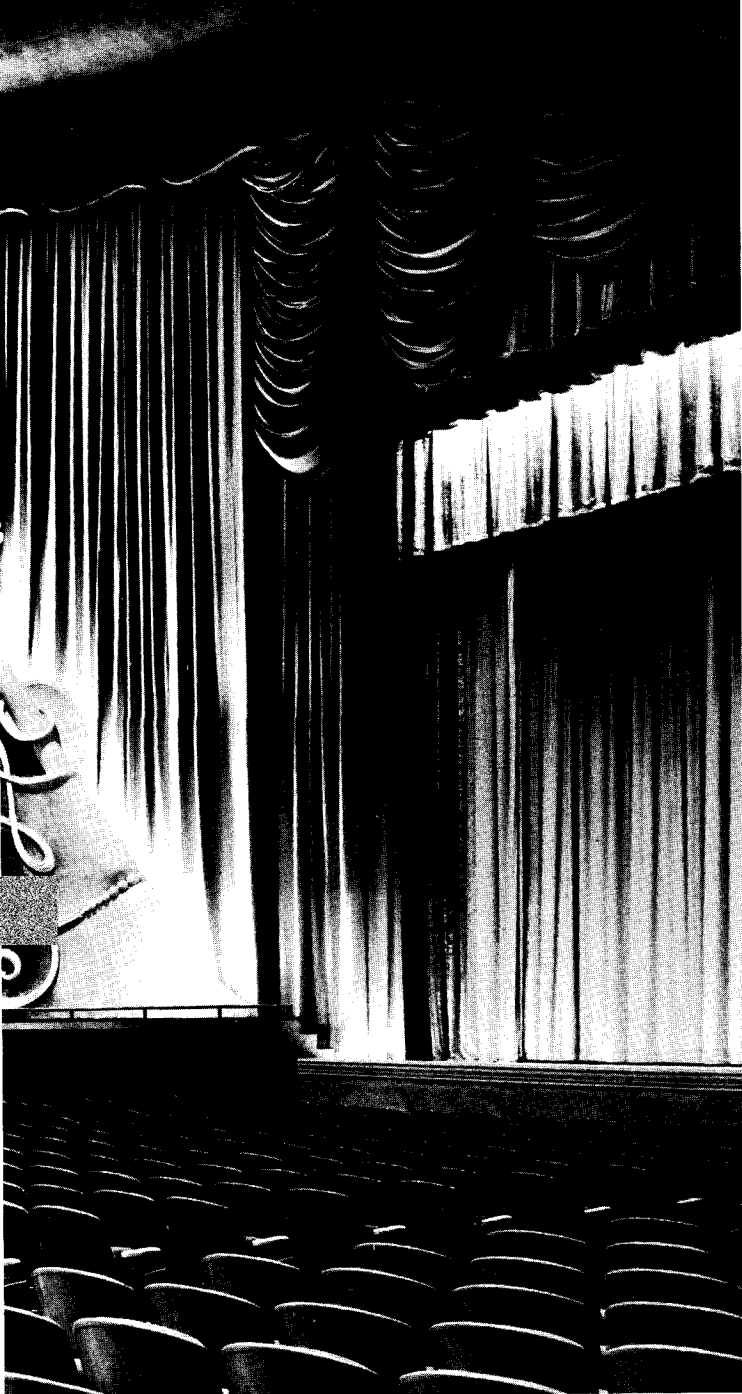

BEACH THEATER, MIAMI BEACH, FLA. ROBERT LAW WEED AND EDWIN T. REEDER, ARCHITECTS; HAL PEREIRA, CONSULTANT. In this recently completed movie theater, two features are of particular design interest: 1. The novel wall treatment of the auditorium, which breaks through conventional conceptions of the proscenium arch and tends visually to unite the audience and presentation. 2. The unusually spacious foyer, lobbies and lounges, which in most instances eliminate standee lines entirely.

In place of the usual proscenium, the screen is flanked by a draped wall which carries around onto the side walls of the auditorium. The curtaining is of copper-colored satin; the walls are a deep blue-green with an all-over pattern of tropical leaves in gray-white.

Illumination under operating conditions is provided by neon lighting in the ceiling coves and in a cove on top of the wainscot. White and blue neon was used, installed in sections that are controlled from the projection booth. Neither light sources nor air conditioning outlets are visible from the seats. Work lights are flush ceiling down lights.

On entering the theater, the left-hand wall of the lobby is of marble from floor to ceiling; the right-hand wall is mirrored with panels of double-strength window glass, secured at the corners by mahogany blocks. At one end of the lobby, a curving bin holds fantastic tropical plant forms made of plastic, copper, aluminum, nickel, brass and fabrics.

CONTINUED OVERPAGE →



Photos by Gottscho



MEZZANINE LOUNGE



POWDER ROOM

As in the main lobby (see photo at right) the carpeted mezzanine lounge also has plant bins surfaced with faience mosaic tile in greens and blues. The powder room is separated from the lounge by a screen of etched glass set in a natural mahogany frame. With the exception of floor and table lamps, all lighting in the lounge is indirect.

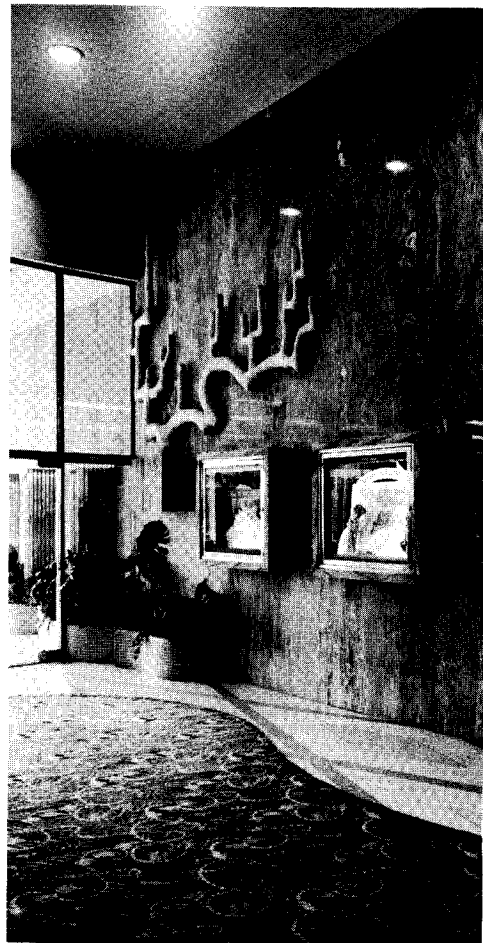

LOBBY DETAIL

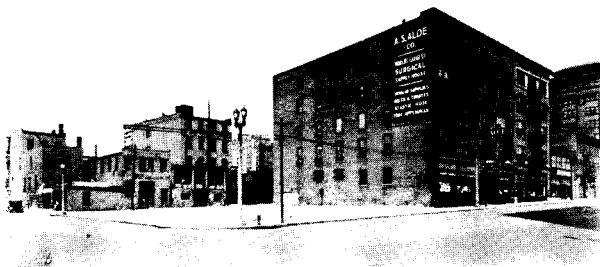

SALES AND OFFICE BUILDING

BUILDING FOR A. S. ALOE COMPANY, ST. LOUIS, MO. WILLIAM P. WACHSMAN ASSOCIATES, ARCHITECTS AND DESIGNERS. The new home of one of the world's largest surgical and hospital supply organizations, the Aloe Building is made up of a new 4-story building on the corner of the site joined with a 5-story building on the side street that formerly housed the company's activities. The two portions are visually united by the continuous bands of steel sash and the exterior surfacing materials. Notable among these are the panels of stainless steel which, with a stone base, sheath the entire ground floor street facades of the building. The company signs, also of stainless steel, are illuminated at night.

Foundations, framing and floor slabs of the new building are of reinforced concrete; above the stainless steel, the street elevation surfaces are of face brick; alley or rear elevations are of concrete. The elliptical lobby dramatizes the building's function; facing the entrance is a two-story-high curved wall of glass which provides an impressive view of the whole main display and sales floor. The lobby floor is terrazzo. A curved stair with an aluminum handrail leads up to the executive, advertising and clerical offices on the floor above; the lobby wall mural, by David Leavitt, depicts the romance, history and symbolism of medicine.



LOBBY



MAIN STAIR



MAIN SELLING ARENA

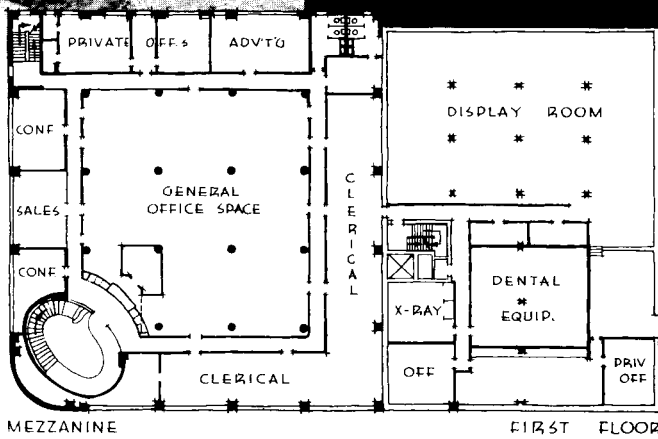

MEZZANINE

FIRST FLOOR

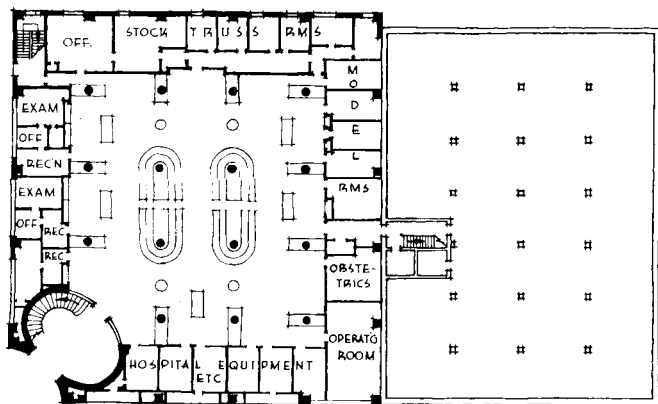

GROUND FLOOR - NEW BUILDING

BASEMENT - EXISTING BUILDING

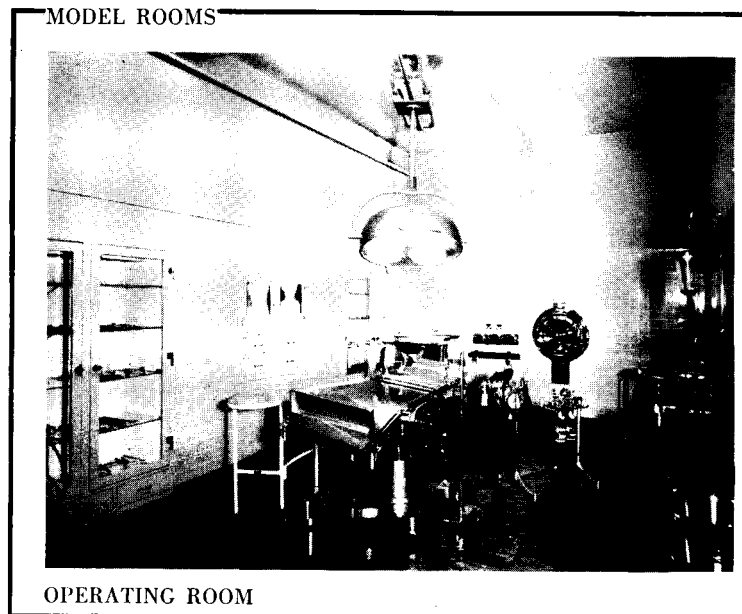

MODEL ROOMS

OPERATING ROOM

Lighting

The lighting problem was solved by the use of both incandescent and fluorescent systems. General illumination is from fluorescent tubing concealed in ceiling covers above traffic lanes; emphasis on special displays or important points is achieved by piercing this general illumination with flush ceiling spots of incandescent light. The open portion of the second floor, devoted to clerical work, is illuminated completely by fluorescent lighting. Lighting of executive offices is by indirect incandescent fixtures.

Display

The merchandise to be displayed consists of a multitudinous variety of objects both large and small—from minute parts of hand instruments all the way up to complete equipment for a doctor's office or a hospital operating room. Display of the smaller objects is handled in four horseshoe-shaped counters in the center of the main floor that form a pair of island sales units. The counters are of white rubbed oak, with interiors in a rich terra cotta color which makes a striking foil for the gleaming merchandise. Walls of the room are a soft gray color. The resilient floor tile picks up the terra cotta color in an inset band. Around this central merchandise display are 24 small display islands either freestanding or built out from the base of the columns. Display is further supplemented by colorful, glazed wall cases. The only major sales department left in the old building is located on the ground floor, along with a repair shop for instruments and apparatus. Floors above contain laboratory equipment and storage lofts.

Model rooms

A specially noteworthy merchandising feature is the series of fully equipped model rooms which border the main floor. At the left of the entrance are physicians' suites—waiting rooms, examination rooms, etc. On the right are hospital equipment displays complete to the last detail—eye, ear, nose and throat treatment rooms; a complete laboratory; an obstetrics delivery room and a complete hospital operating room with tile walls and equipment permanently installed. Along another wall are three model hospital patients' rooms and three specialized treatment rooms.



CONFERENCE ROOM



EXECUTIVE'S OFFICE

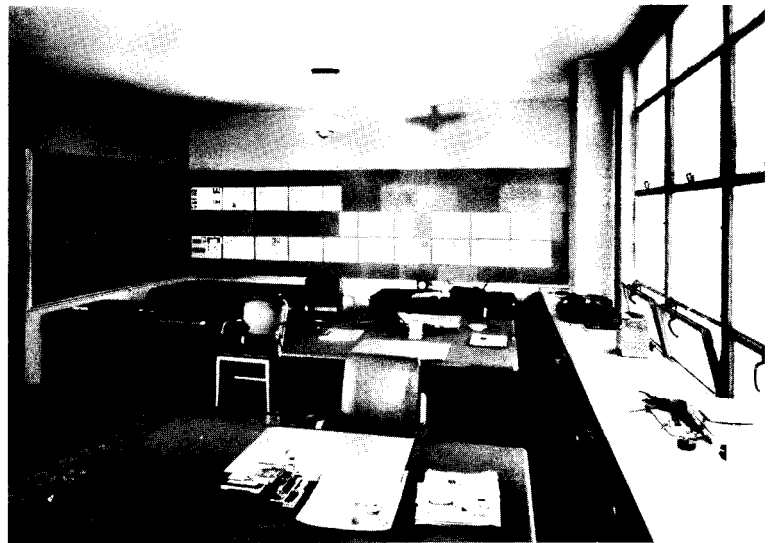

ADVERTISING DEPARTMENT



EXAMINATION ROOMS

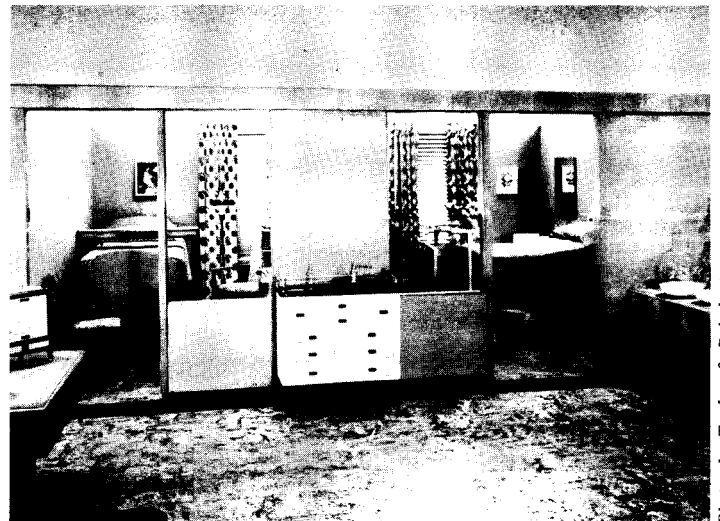

HOSPITAL ROOMS

Photos by Tucker & Poindexter



CLUB HOUSE

PALM SPRINGS WOMEN'S CLUB, PALM SPRINGS, CALIF. JOHN PORTER CLARK, ARCHITECT. Basic design requirements for this successful small club house were: an auditorium to seat a membership of 150, with provision for greater attendance on special occasions; a place in which to serve teas; flexible facilities for various types of social gatherings. In addition, the building had to come within a budget of \$12,000. The architect satisfied these demands by (1) employing a simple frame and stucco structural system and (2) by an adroit ordering of elements whereby areas are made to serve more than one purpose.

The centrally located sun room serves both its primary purpose as a lounge for informal gatherings and teas and as accommodation for audience overflow from either the inside auditorium or the walled-in patio. The latter is equipped with an outdoor stage at the far end. Both sun room and patio are served directly from the caterer's kitchen. The auditorium stage is accessible either from the auditorium floor or through a concealed entrance from the hall.

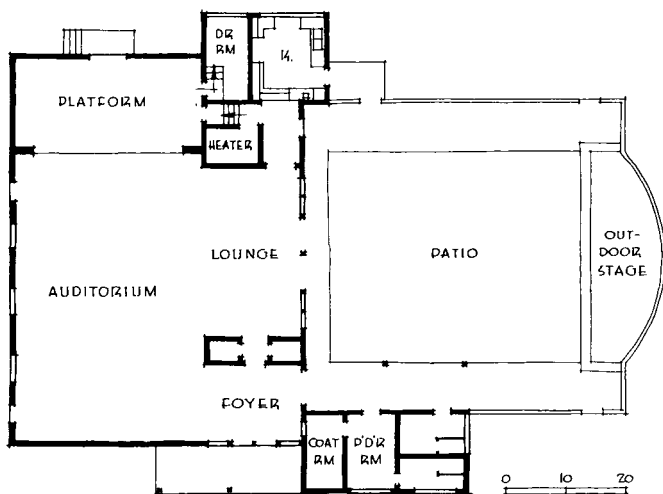



EXTERIOR PLASTER WALLS are coral in tone; the roof is of tan tile



THE OAK-FLOORED AUDITORIUM is frequently used for community dances



THE WALLED PATIO also serves as an outdoor auditorium

Don Taylor

HIGH SCHOOL

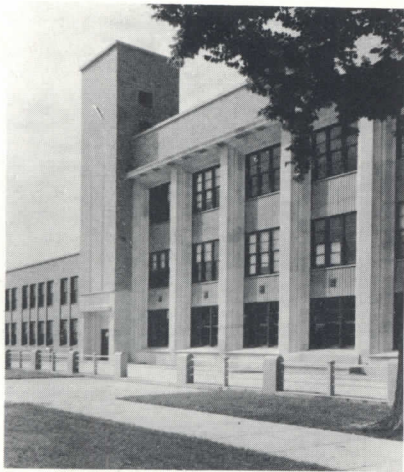
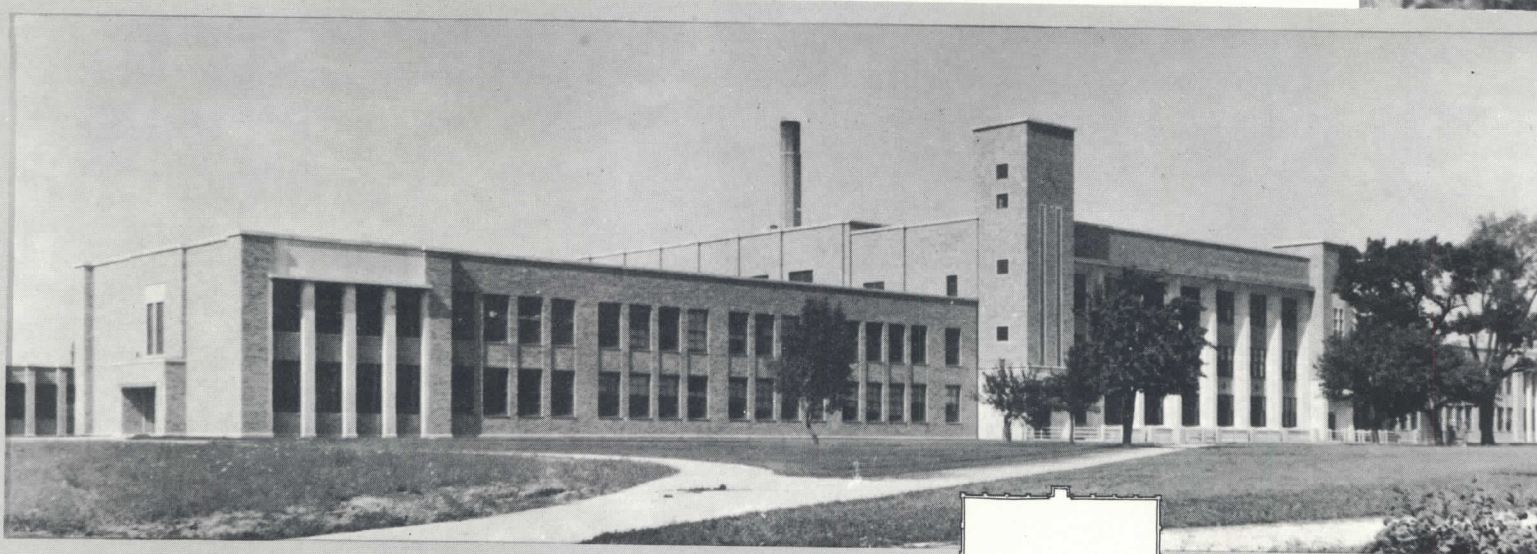

**ARTHUR HILL HIGH SCHOOL, SAGINAW, MICH.
ROBERT FRANTZ and JAMES SPENCE, ARCHITECTS.**

The school is located on a 70-acre site, with ample provisions for driveways, parking, baseball and football fields, etc. A joint project of the Board of Education and PWA (1939-40), the design was worked out after four years' study in conjunction with Chester F. Miller, Superintendent of Schools, and Dr. Arthur B. Moehlman, Consultant on Educational Design. Present capacity is 1,700 students; future extension of wings will eventually take care of 2,400. Locker and shower facilities for boys and girls are in the basement with direct access to the play fields at the rear. All corridors are 14 ft. wide to prevent congestion; fire extinguishers or hose cabinets are within from 50 to 100 ft. of every point in the building; an exit is within 10 ft. of every classroom. Construction is of concrete-fireproofed steel frame; concrete slab-joint floors; brick and stone facing; aluminum spandrels, window sills and marquis facings. Cost of the building including the separate power plant came to \$1,282,850 or 31 cents per cu. ft.

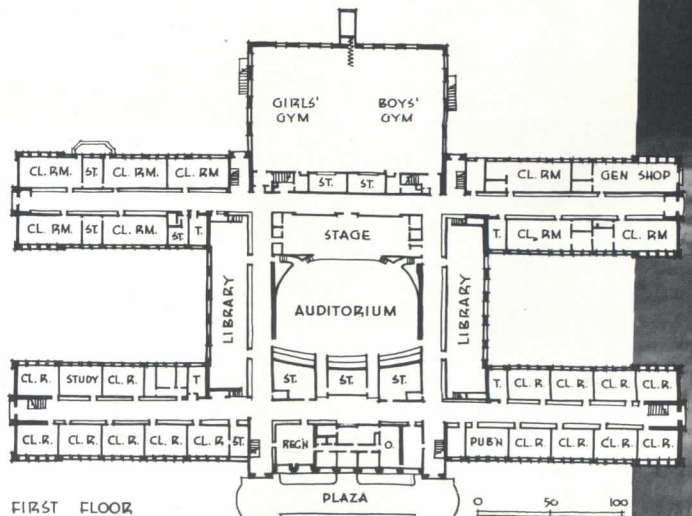
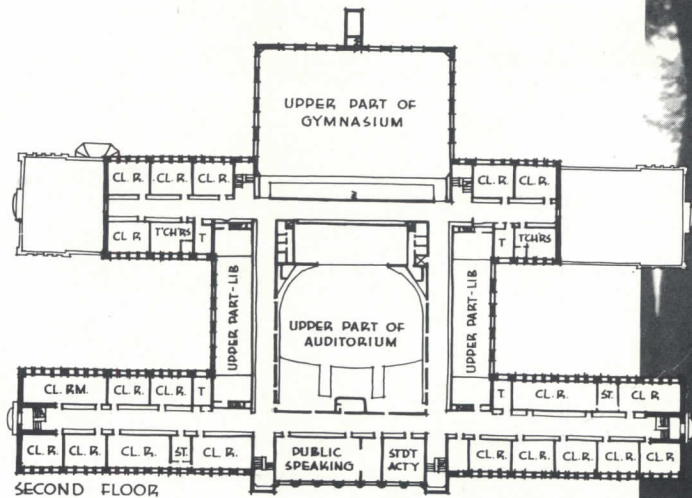
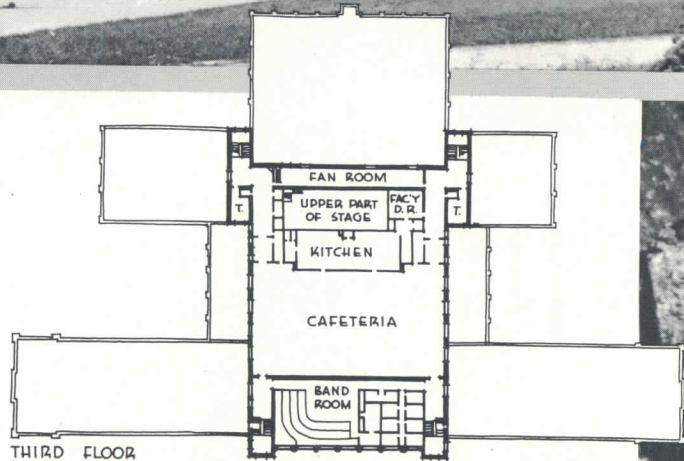





AUDITORIUM CORRIDOR

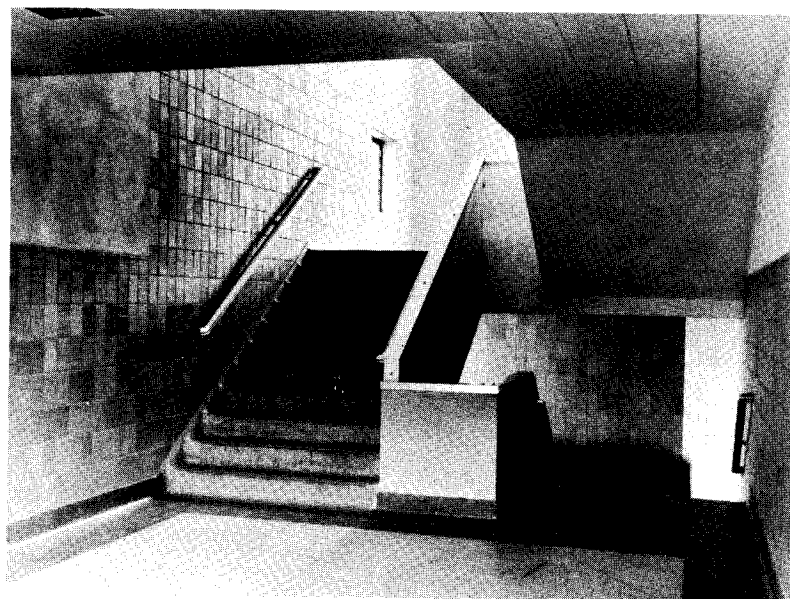

TYPICAL STAIR



TYPICAL CORRIDOR

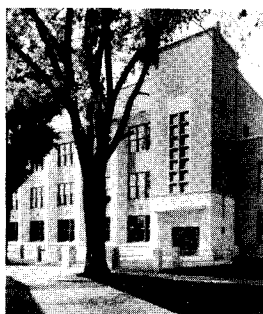

SAFETY

IN ADDITION to the 14-ft. corridors, fire-fighting equipment and numerous well located exits, safety provisions include: electrically operated rolling plywood partition in the gymnasium which folds into a recessed compartment without any projection into the room; passenger elevator for disabled students, heating plant 100 ft. away from main building, auditorium projection booth vented direct to the outside; fire doors and shutters on all openings; and fire alarms 100 ft. apart that are operated independently direct to the Fire Department. Gym equipment is housed behind flush doors; there are no thresholds; door mats are depressed flush; stairways have daylight. Pianos are located in recesses; thermostat shower valves prevent scald accidents; classroom doors are fitted with clear glass panels.

Photos by George H. Van Anda



PUBLIC SPEAKING CLASSROOM

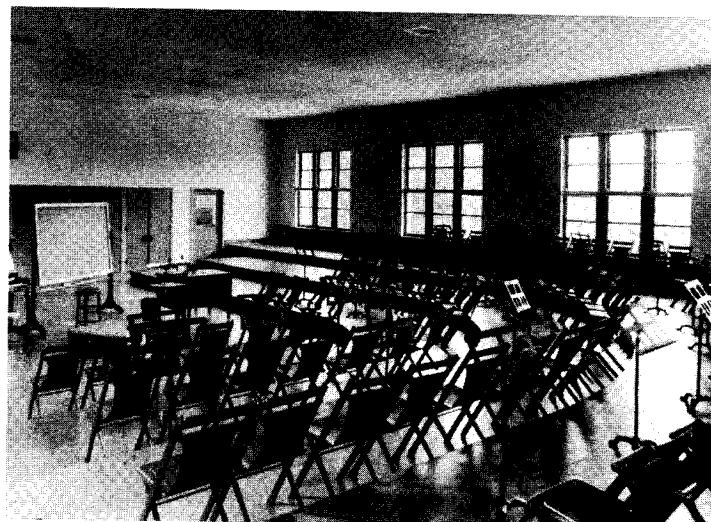

BAND ROOM

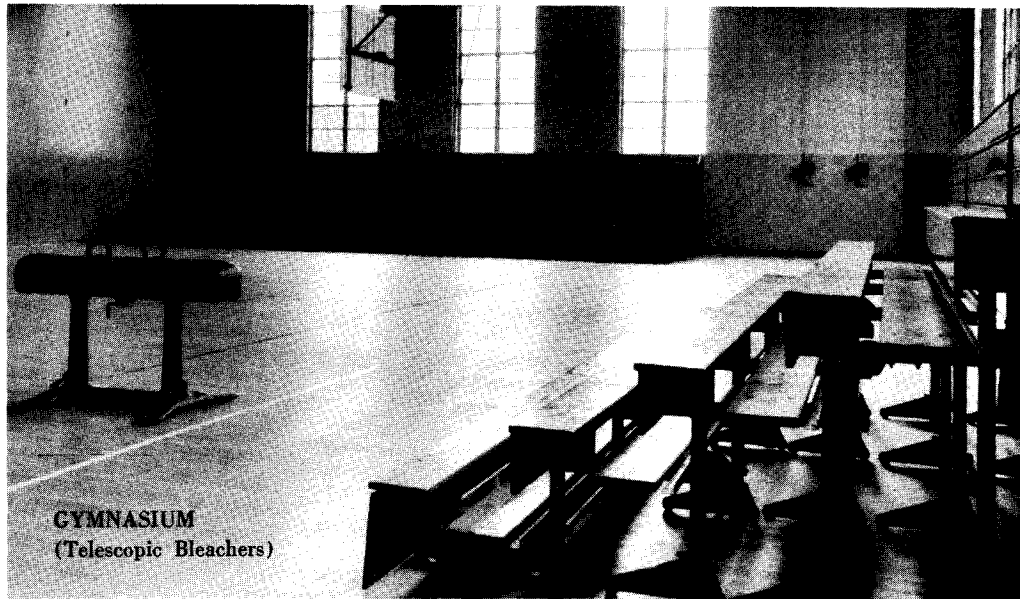

GYMNASIUM
(Telescopic Bleachers)

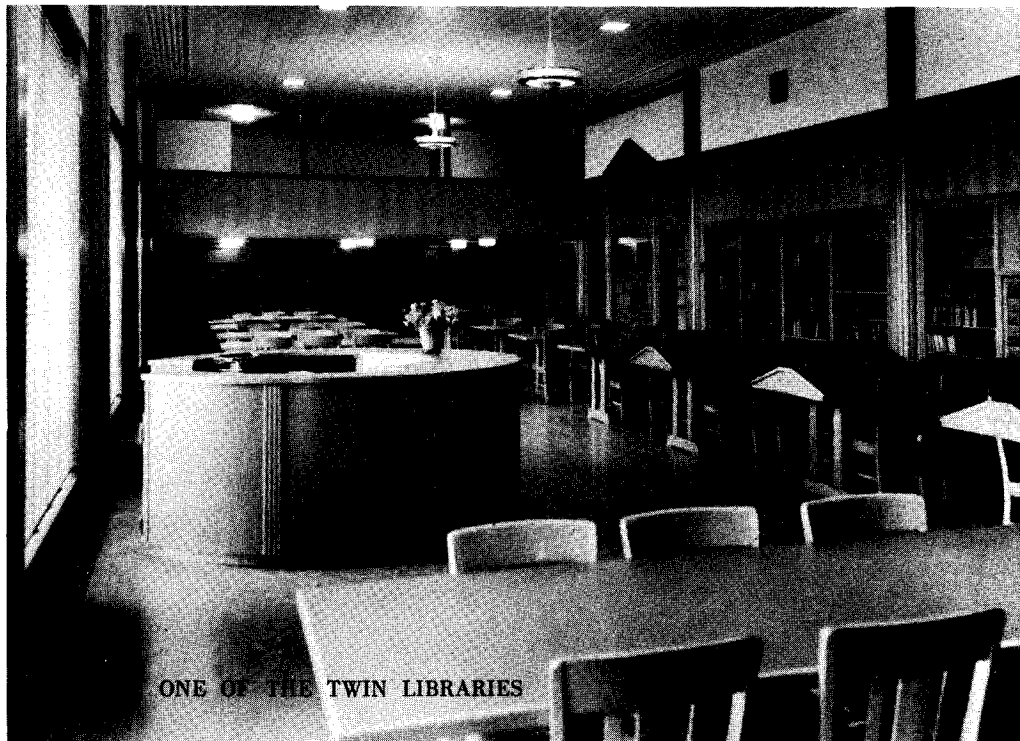
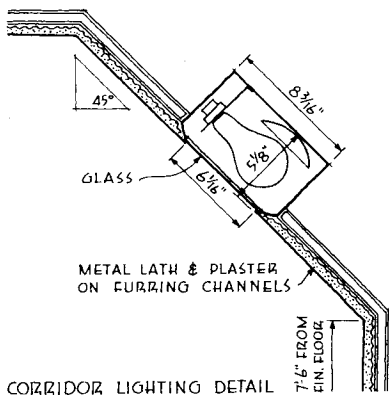

ONE OF THE TWIN LIBRARIES

HEAT AND LIGHT

HEATING is of the split type; fan rooms are in various locations—over the twin libraries, over the stage, etc., with separate controls for the gymnasiums, the auditorium and each of the wings. All rooms and corridors have acoustic ceilings. Corridor lighting is made up of flush recessed units set into beveled ceiling elements (see detail above). The lenses spread the light down into the lockers and out into the corridors. Gym lights are flush in the ceiling with unbreakable glass. Classroom lighting is controlled by electric eye, insuring automatic proper intensity from suspended-type fixtures. Flush ceiling flood lights occur above all blackboards. For details of auditorium and cafeteria lighting systems, see pages 58 and 59.

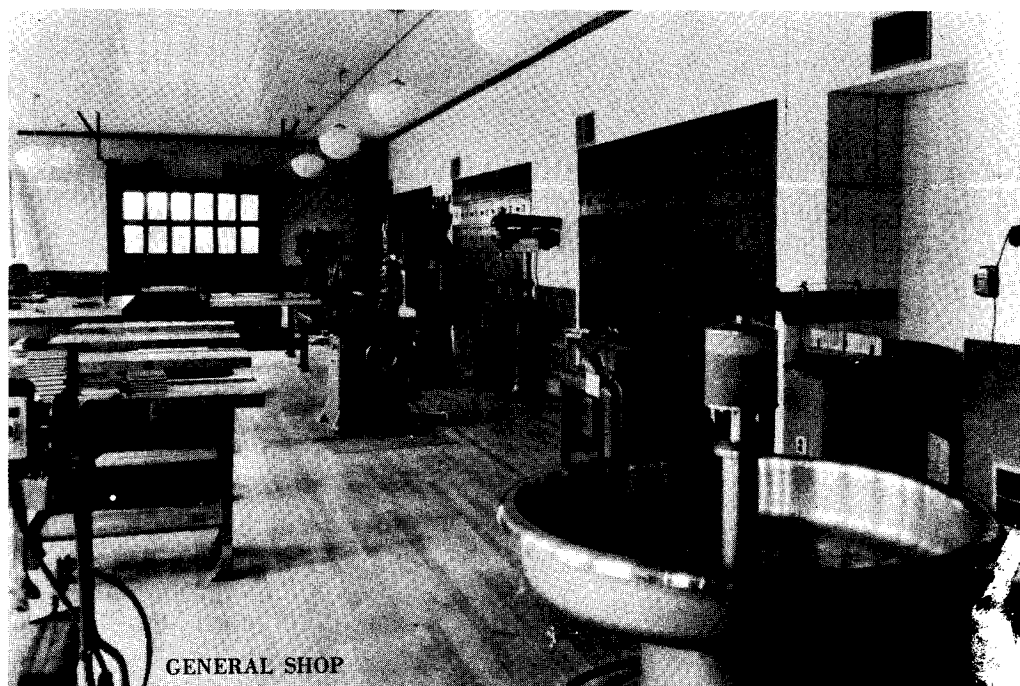

GENERAL SHOP

AUDITORIUM

THE AUDITORIUM is of the stadium type with seats for 1,008 on the main floor and 466 in the balcony portion. Provisions for the control of light and sound were major determinants in the treatment of the room. To break up sound travel, both walls and ceilings are divided into coves. Within these, lighting and air-distributing elements are incorporated in such a way that they are not visible from the seats. Continuous fluorescent tubing is carried in alternate coves up the sides of the room and curved across the ceiling. Supplementary work lights are mounted flush in the ceiling. Every other ceiling cove contains ventilating louvres. Access to both lighting and ventilating is by means of catwalks that come between the suspended ceiling and floor slab above. There is space for a 90-piece orchestra in the pit. Above a plywood dado, the side walls and ceiling are of plaster; the rear wall is surfaced with acoustic material.

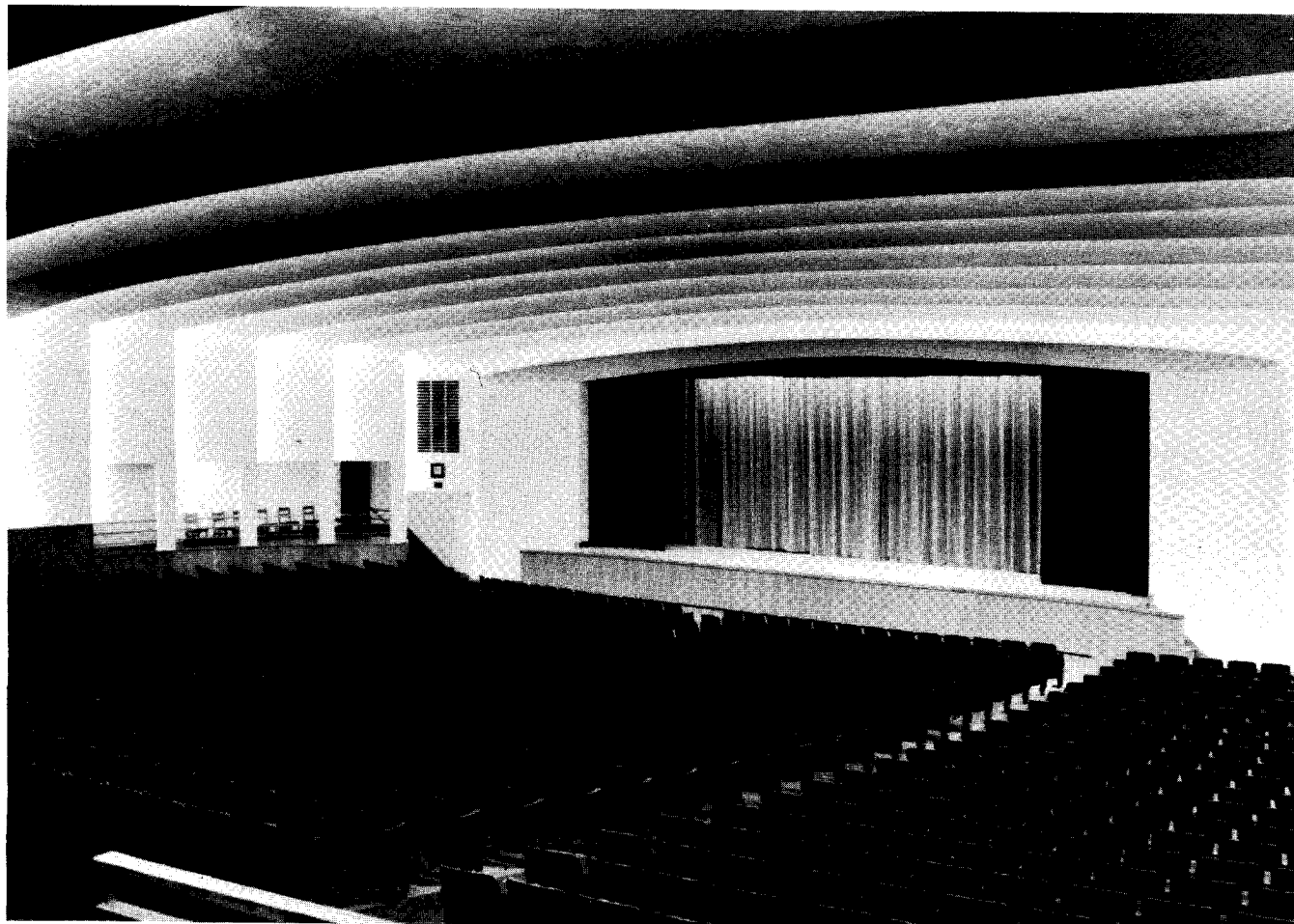
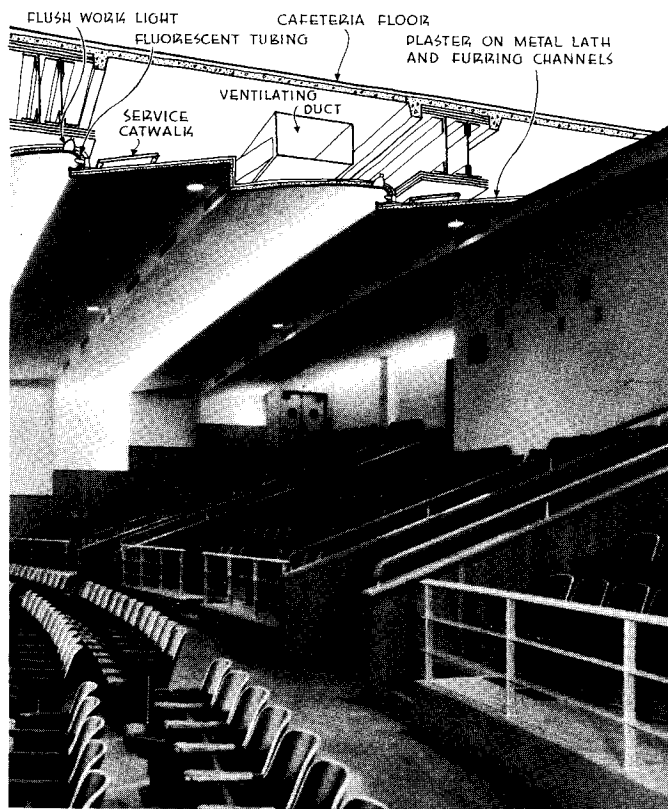

Photos by George H. Van Anda

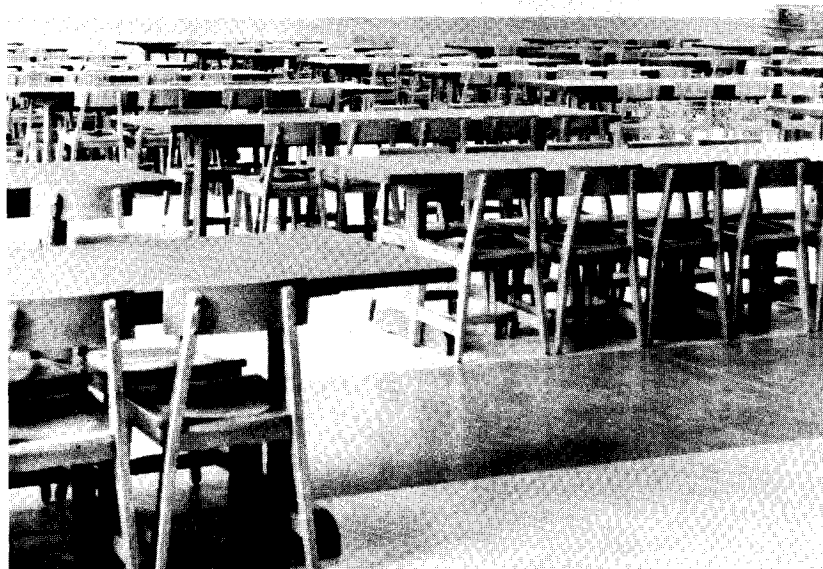
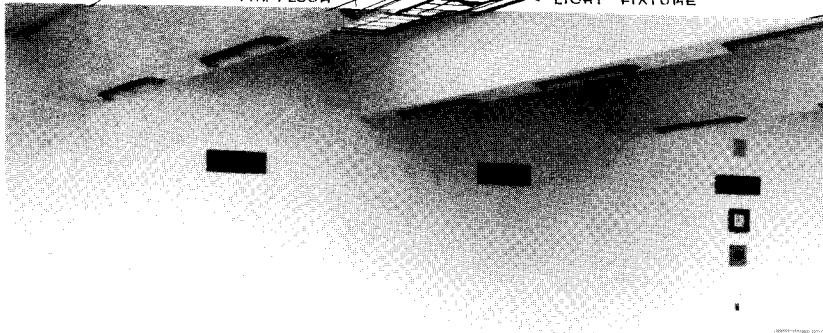
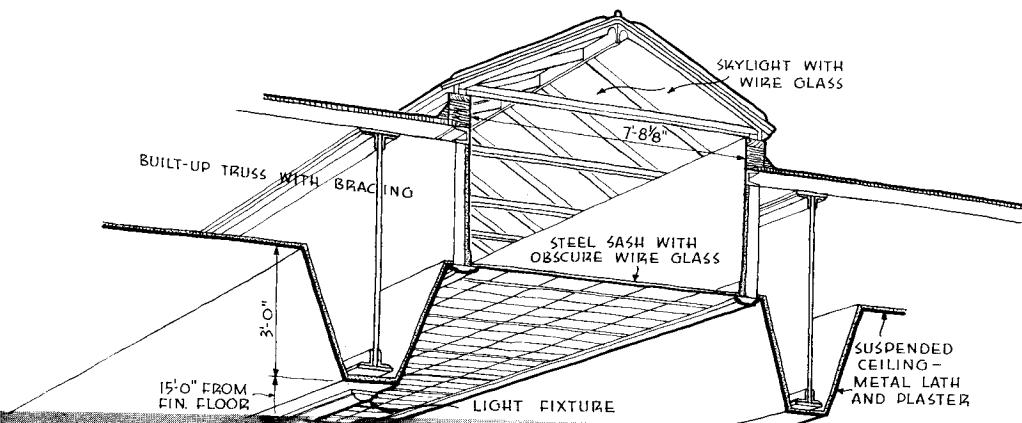
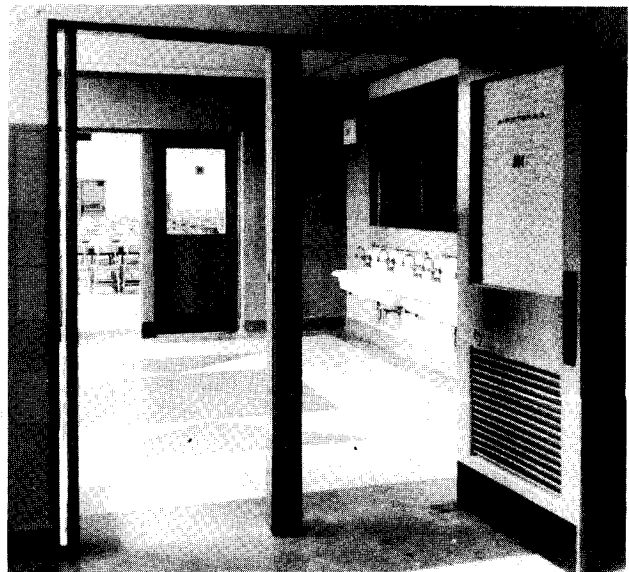
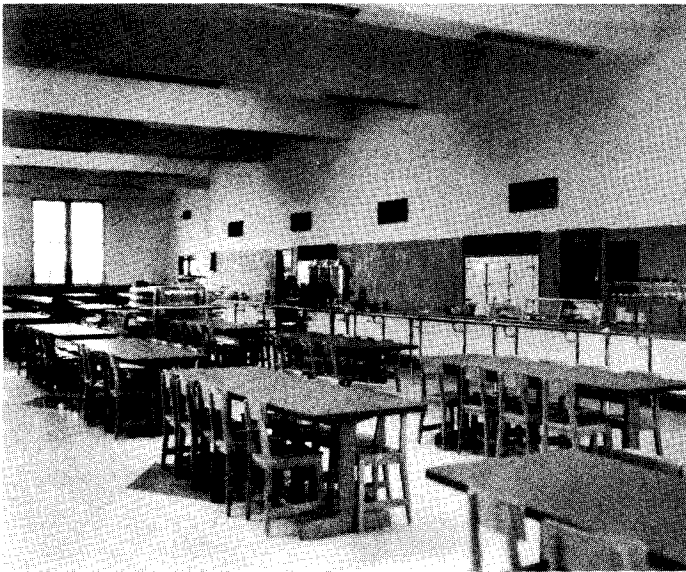

CAFETERIA

THE SCHOOL CAFETERIA, located above the auditorium on the third floor, seats 600.

An unusual amount of daylighting comes from both wall and sky lights. At night, the room is illuminated from built-in fluorescent fixtures that are integrated with the beam framing. The floor is terrazzo; walls are of brick tile (wainscot) and plaster. Along the walls of both entrance and exit rooms are gang washing facilities (see photo above, at right). Kitchen deliveries are made by elevator.

FACTORY

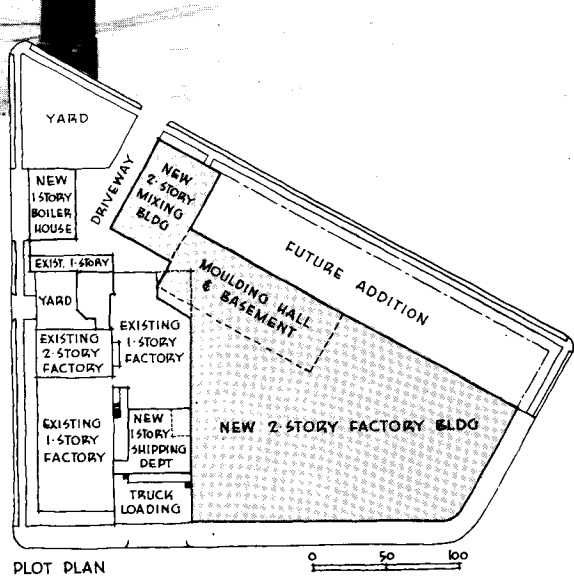
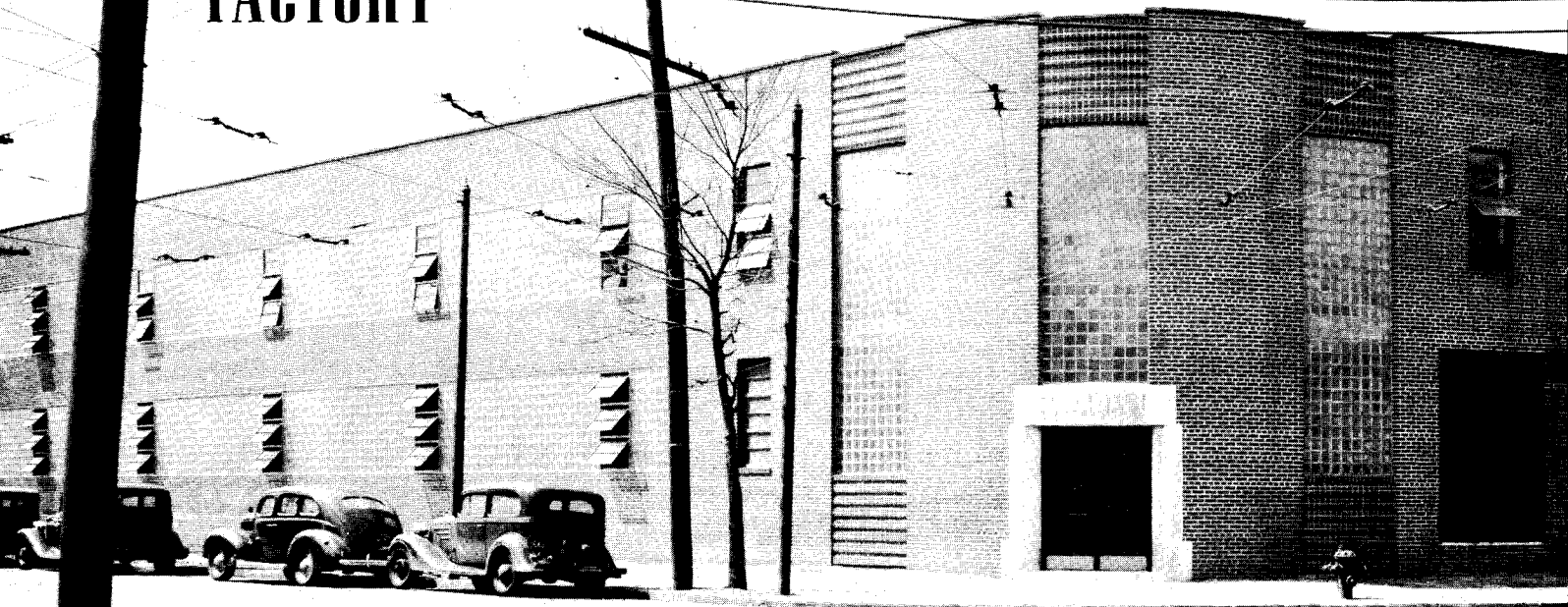

BUILDING FOR THE CELLULOPLASTIC CORPORATION, NEWARK, N. J. DAVID SICHEL, ARCHITECT. Several specialized problems entered into the design of this addition to an industrial plant: irregular-shaped site; need for extreme safety provisions due to the hazardous nature of the fabrication process; ordering of areas to serve carefully timed flow-line production; special provisions for ventilation and light.

Structurally the building is a combination of reinforced concrete flat slab construction and fireproofed structural steel. Placement of columns inside the envelope allowed the use of continuous bands of windows, made up of glass block panels with clear sash units at about 20-ft. intervals.

Among the safety provisions are: 12-in. fire walls and fire doors separating hazardous areas; explosion vents and explosion type steel sash; complete fire prevention equipment; sprinkler system connection to both high and low pressure mains; fireproof structure throughout; plant signal systems; explosion-proof wiring and equipment.

Large electric roof ventilators serve the second-floor finishing department; the first floor is ventilated by air which is sent in under pressure and leaves through the windows. This is supplemented by individual exhaust systems for special processes.



THE TALL GLASS-BLOCK PANELS light the two-story Moulding Hall

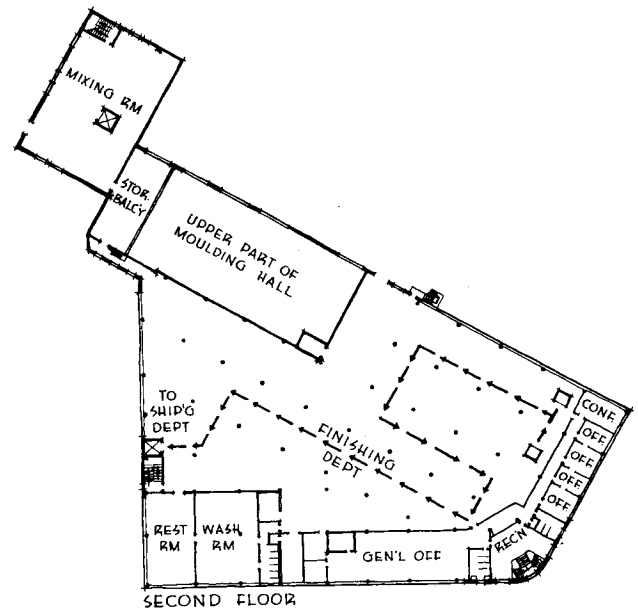

SECOND FLOOR

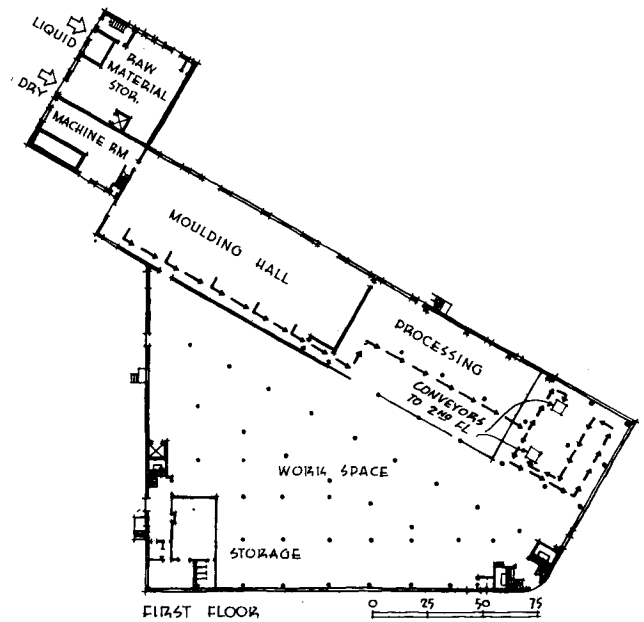

FIRST FLOOR

In general, the flow line is as follows: Raw materials, both liquid and dry, enter the plant at the point indicated by arrows on the first-floor plan. From here they are hoisted or pumped directly above to the second-floor mixing room. Gravity brings the mix down into the two-story moulding hall. From here conveyors carry the material in a line through several processing steps to the end of the building where overhead conveyors take it up to the second floor for finishing. The product is then packed and carried down by elevator to the shipping department and truck platform.

Second-floor business offices are so arranged that employees may pass from one wing to the other without entering the public area.



GENERAL OFFICE SPACE on the second floor

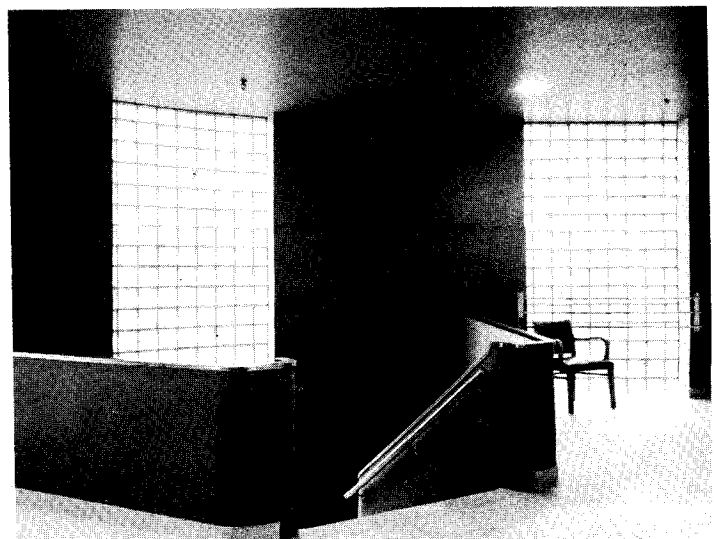

STAIR HALL at entrance to business offices



Photos by St. Thomas

NEWSPAPER PLANT AND OFFICE BUILDING

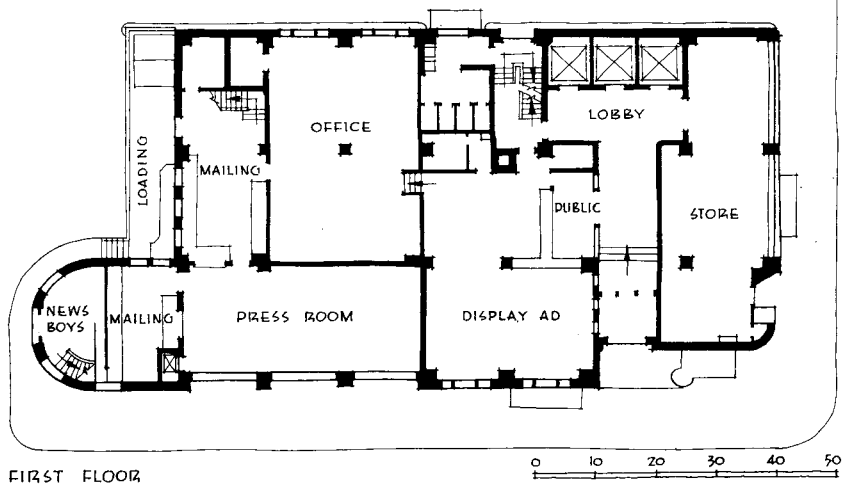
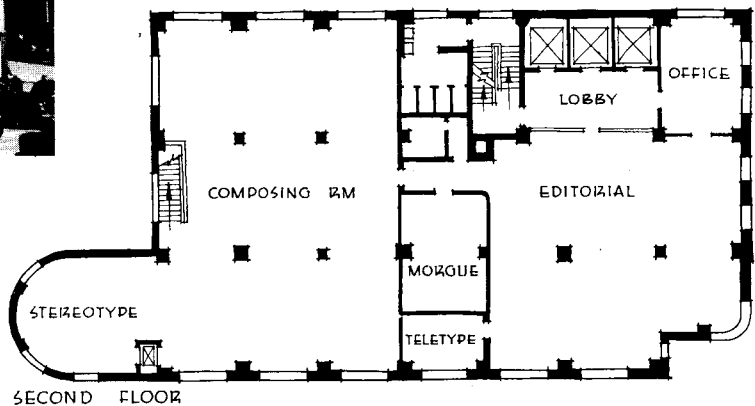
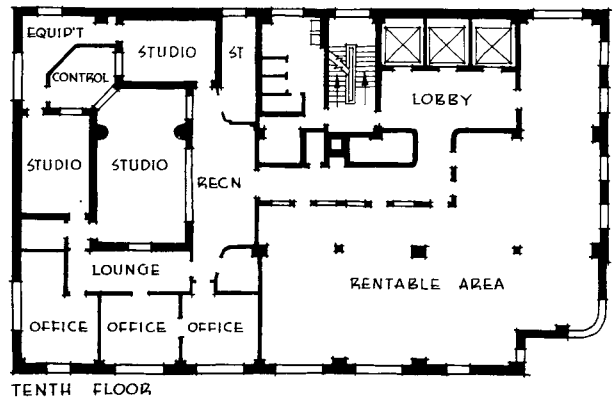
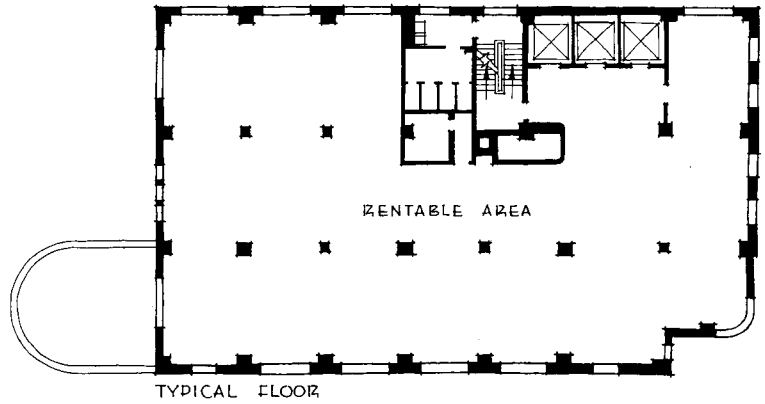

AUSTIN DAILY TRIBUNE BUILDING, AUSTIN, TEXAS. SHIRLEY SIMONS, ARCHITECT; PAGE, SOUTHERLAND & PAGE, ASSOCIATE ARCHITECTS. The basic planning problem was to combine two major but entirely different functional elements—a modern newspaper plant and a revenue-producing office building—into a dignified modern structure that would do honor to a daily paper dedicated to the welfare of the people of Texas. In addition, space was needed for radio-broadcasting studios, a ground-floor rental area and a penthouse apartment. While revenue demands made careful planning of the typical office floor a requisite, the type of clientele sought required considerably more than commercial minimum of space, finish and detail. Structure consists of reinforced concrete frame, pans and joists. Exterior walls are of hollow tile; cream-colored, smooth-textured face brick; Texas limestone trim, and a variegated red and black granite base. Trim and sash are of aluminum.

Photos by St. Thomas

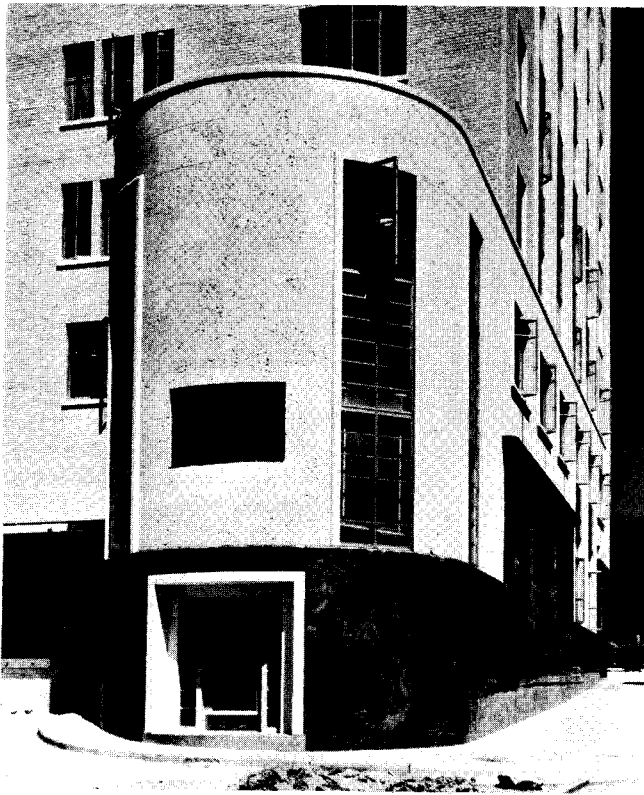

THE NEWSPAPER OFFICES occupy the lower floors, at left of the main lobby. Each department is located according to its function. For instance, the advertising and circulation offices—the two departments with which the public most often comes in contact—are immediately accessible from the public area. Press room and paper delivery department also demanded a location at street-floor level. On the second floor, editorial and news assembly rooms are located near composing room and stereotype departments; the editorial and news rooms, placed toward the front of the building, have contact with the public through the main stairs and the office-building elevators. The composing room is placed immediately above the press room and has direct connection with it by both service elevator and stairs. On a mezzanine level, between the composing room and press room, are locker, shower and wash-room facilities. Car-load paper storage is provided just below the press room.

The curved windows at each office floor level afford a full view of the state capitol grounds. The two-story semi-circular element at the opposite end of the building masks the loading area of the distribution department and affords safe and convenient space for the newsboys. The roof above

this projecting element provides direct venting for heavy-duty composing room machinery.

In offices and corridors, floors are of terrazzo; asphalt tile and edge-grain pine blocks are used in the newspaper space; wash rooms and toilets have ceramic tile floors. The main lobby walls are finished in marble.

Fluorescent lighting is used throughout the first floor. The building is equipped with an electric clock system, master clock, relay control cabinet and secondary clocks; telephone and telegraph systems.

The radio studios on the tenth floor are insulated against sound and vibration; construction consists of a 9-in. brick wall, with hollow center; double plate glass observation windows; plaster walls and ceilings with acoustic panels; sound-proof doors, and floors surfaced either in carpet or rubber tile.

The entire building is year-round air conditioned. Separate systems govern the newspaper plant and the office floors. Additional systems serve the rental space on the first floor, the radio studios on the tenth and the penthouse apartment on the eleventh floor; temperature is automatically controlled.

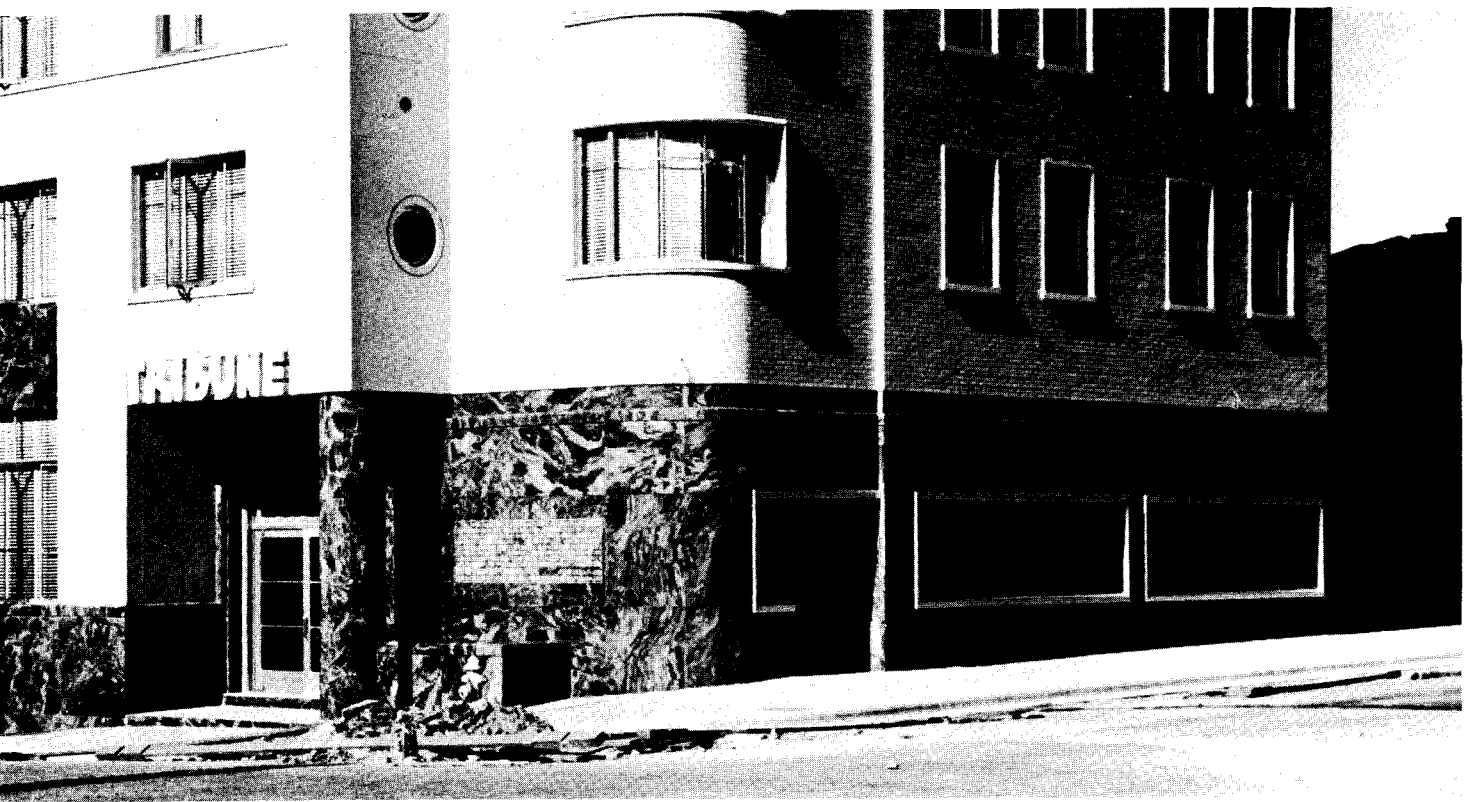

SPORTS ARENA

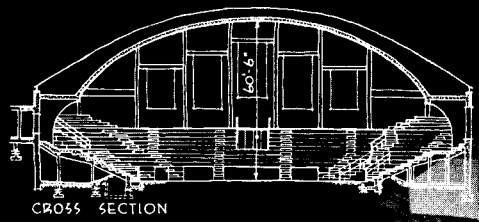

Photos by Ezra Stoller

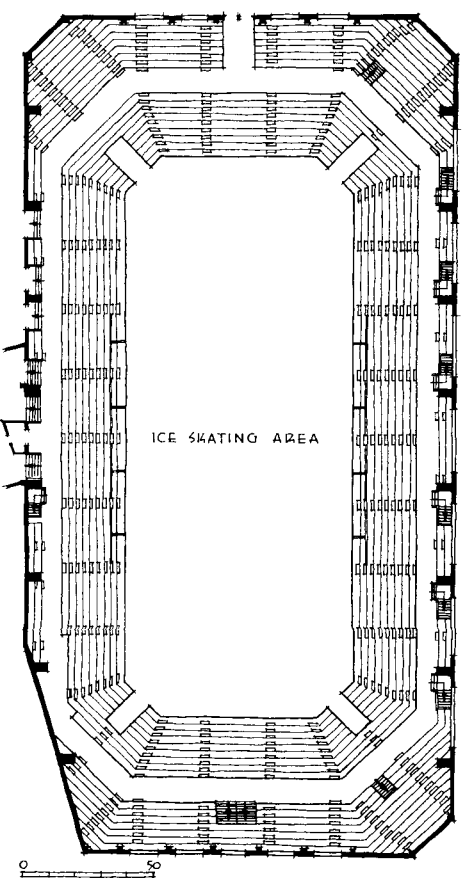

ULINE SPORTS ARENA, WASHINGTON, D. C. JOE HARRY LAPISH, ARCHITECT. The arena accommodates all types of events from ice hockey (seating capacity 5,200) to basketball (6,500) to boxing (8,500) to dances and public gatherings. In space beneath the seats are service rooms, toilets, lunch counters, dressing rooms, etc., and storage space for boxing equipment, the board track, sectional dance floor and movable seats.

To enclose the huge area, 324 ft. in length with a clear span of 164 ft., the Z-D system of monolithic reinforced concrete construction was used. Eight arch ribs carry the concrete barrel shell, which is only $3\frac{5}{8}$ -in. thick at the crown, increasing in thickness to $5\frac{1}{4}$ in. at the spring line. The shell is divided into five independent-acting sections by 4 transverse expansion joints midway between every second rib. The arch ribs have a width of 18 in. and a depth of 5 ft. at the crown, continuing down on the hinge at a point approximately at the highest level of the seating, where the supporting haunch has a section of 3 by 6 ft. Due to site restrictions, the haunches go down vertically to the footings, and the seating balconies are so designed as to neutralize the outward horizontal thrust of the arch ribs. Each of the five curved roof sections and adjoining arch ribs between expansion joints was poured in one continuous operation. Exterior curtain walls are of cement block surfaced with face brick on the exterior.

The rink floor is a patented monolithic floor construction which consists in general of the main supply and return headers running under the long axis of the floor, from which 1-in. iron pipe spaced 4 in. on center take off transversely and carry the refrigerant through the entire concrete slab. The floor is reinforced with quarter-inch steel bars below the pipe, spaced 5 in. on center each way. The concrete for the floor was poured in a single operation.

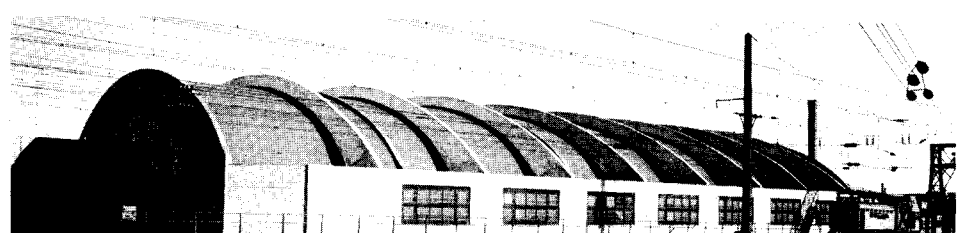

Tenant Adjustments Show Need for NEW STANDARDS IN APARTMENT DESIGN

Although based upon tenant adjustment experience in several public housing projects in New York City, the usefulness of the following study is by no means confined to "public" or "low-rent" housing. On the contrary, the deficiencies described apply with equal force to all types of multi-family housing—public or private, low-rent or de luxe. This study has been prepared with the assistance of LOUIS SACKMAN, formerly of the Interior Design Staff of the Works Projects Administration, and is based on the final report of the members of this staff.

APPROXIMATELY 200,000 American families are now living in public housing projects ranging from the 8-story elevator units of New York to the 1-story detached houses of Texas defense projects. A vast accumulation of experience (in site-planning, unit planning, construction and maintenance) has resulted in minimum standards whose accuracy is already established. But a new set of problems is emerging from this experience—problems which indicate the need for (1) a much more *detailed knowledge* of what tenant requirements actually are, and (2) the formulation of much more *precise standards* of unit planning.

The problem of *adjusting the amount and organization of space in a dwelling unit to meet the growing and changing needs of its occupants* now becomes of *paramount importance*. Formerly it was thought enough to provide "parlour," dining room, kitchen, and bedrooms, to take care of a comparatively simple family life in a relatively large space. Then apartments began to be classified by rooms—2, 2½, 3, 3½, etc.; and occupancy by ratio—1, 1½, 2 persons per room. But this unit of measurement for dwelling space, though better than its predecessors, is still insufficiently precise. Today family life has become more complex, with a much greater diversity of home activities. While more demands are made upon the dwelling unit, the space remains the same and many times grows relatively smaller. Thus the architect is faced with the problem of adjusting a fixed or diminishing living space to an increased, more complex family life.

Calling attention to this fact, the

Committee on Hygiene of Housing observes*: "The new projects being built under the housing program have to meet a number of space requirements which are supposed to represent at least minimum standards for healthy and decent living. In many instances, however, standards thus established cannot be put down in specific figures but result in such general principles or statements as 'adequate space,' 'adequate privacy,' etc., and permit, therefore, of a broad interpretation by those who are to put them into practice . . .

"In addition to the mere provision of shelter and of sanitary and mechanical equipment, the amount and the arrangement of space are among the most important factors which determine the usability of a dwelling. Therefore, buildings ought to be planned so that, aside from their physical ability to survive an amortization period of 60 years, they should not become obsolete in terms of their use by people. Once the structure is completed and space-divisions are permanently established, changes of the plan to meet requirements not originally contemplated are extremely difficult with the present method of construction."

These conclusions are substantiated by first hand experience of the Interior Design Staff† in two New York City housing projects. This Staff was set up to act in a consultative capacity to all tenants in the projects who re-

*In its forthcoming report, "Principles of Space Planning and Space Organization for Low Rent Dwelling Units"; American Public Health Association, New Haven, Conn.

†The Staff was a WPA project, set up at Red Hook and Williamsburg Housing Projects with the cooperation of the New York City Housing Authority.

quested assistance in "getting settled." The experience of the Staff was wide and varied; but the problems met with and the solutions arrived at could be grouped under the following general classifications:

1. Need for tenant guidance

Many of the cases handled involved lack of understanding of basic home-planning principles on the part of the tenants. In such cases, the Staff could analyze the family's living patterns, showing *how* and *why* the room use and furniture placement could be re-organized to better advantage. Such cases were those shown in Figs. 5, 6, 7, 8. More difficult, yet closely related to this problem, was that of adapting living patterns or habits which the family brought with them based on having previously lived in entirely different types of dwelling units.

2. Furniture deficiencies

Almost every case handled by the Staff revealed important deficiencies in the furniture and equipment brought in by the tenants. There was either too much (Fig. 8) or too little (Fig. 10). Much of it was "oversize"—too large in scale (Figs. 8, 14), poorly designed and badly built (Fig. 7). Most common was a shortage of basic *storage* pieces—chests, dressers, cabinets, book-shelves, etc.—and convertible beds. The Staff limited its recommendations for buying to those pieces which were essential and which tenants could afford to buy. In this connection, the Staff's advice on furniture buying proved the need for consumer guidance in such matters (Figs. 5, 6).

3. Overcrowding

It was found that both parents and

a child 2 years of age or over slept in the same room in 32 out of 37 3-room apartments. Children of different sexes 6 years of age or over slept in the same room in 12 out of 102 apartments. Such problem situations could have been avoided if the living room were used for sleeping, as was done in 11 out of 102 apartments. The open plan living room in many of the Red Hook apartments does not provide sufficient privacy for anyone who may have to sleep there (see Figs. 8, 11, 12). If and when occupancy standards make allowances for sufficient rooms so that no one will have to sleep in the living room, arrangements for sleeping there will no longer be a problem. Now, however, many families do use the living room for sleeping and many others should because of growing children and crowded bedrooms.

4. Lack of indoor play areas

Space should be provided in the

dwelling where children can play and store their playthings. This is important for a more complete development of the child's personality; it also reduces the amount of housework (the average housewife works about 60 hours per week) and helps to eliminate friction which might arise were the child to get in the way of another child or adult member of the family. At Red Hook, in at least 30 out of 102 apartments, most of which contained children, no provision was made for play areas. Many tenants did not recognize this as an important consideration when furnishing the apartment, and others could not make provision for play space because of the arrangement of walls, windows, and radiators.

5. Pros and cons of combination rooms

In smaller apartments it was found that many of the difficulties listed above could be eliminated if the rooms were planned not as "living rooms" or

"bedrooms" but as combination living-bed rooms based upon the specific needs of the individual family. In 60 out of 102 apartments, the living room either was or should have been used for sleeping. The value of such planning is obvious when we compare Figs. 5 and 8, taken from the records of tenant consultations of the Interior Design Staff.

Although housing authorities may prefer that the living room not be slept in, this is the only advisable thing to do in many cases (Figs. 5, 8, 11). Because of the room size and shape, the location of windows and radiators, it is often difficult to arrange the furniture conveniently. A person in the living room cannot sleep comfortably with his head toward the window because the radiator is too close to the bed. Facing the window makes it difficult to sleep when early morning light enters the window. In

BASIC FURNITURE UNITS

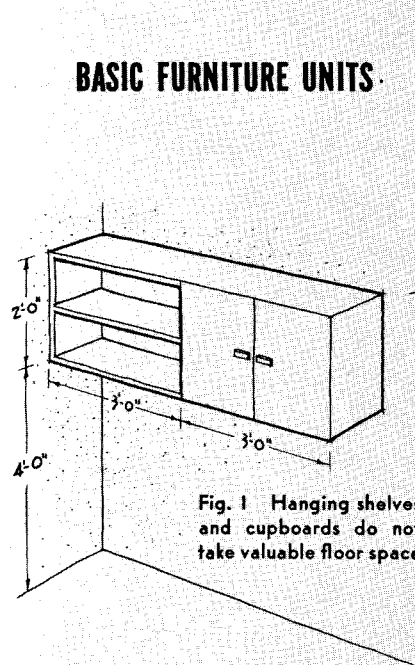

Fig. 1 Hanging shelves and cupboards do not take valuable floor space

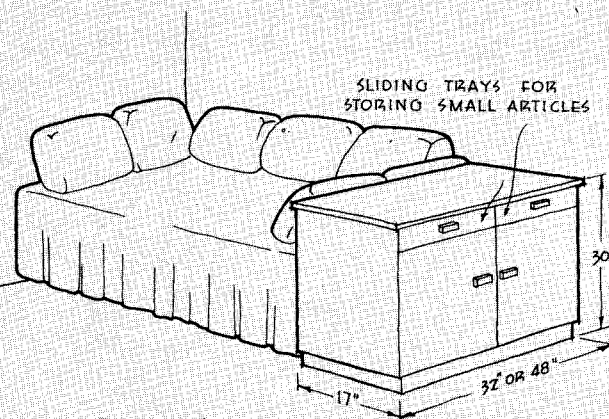

Fig. 2 Where beds are used as couches in daytime, combination end table and chest serves as storage for bedding and/or clothing

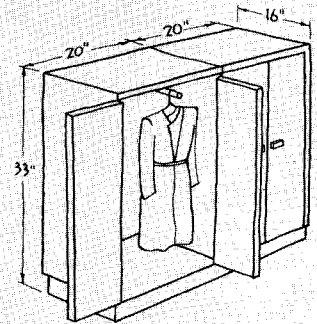

Fig. 3 Storage cabinets for children's clothes and toys. Also suitable for adults' clothing

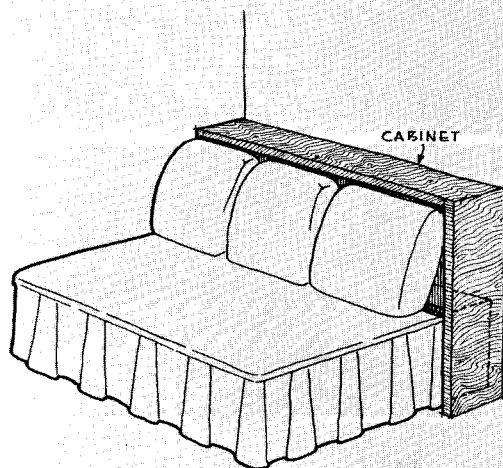
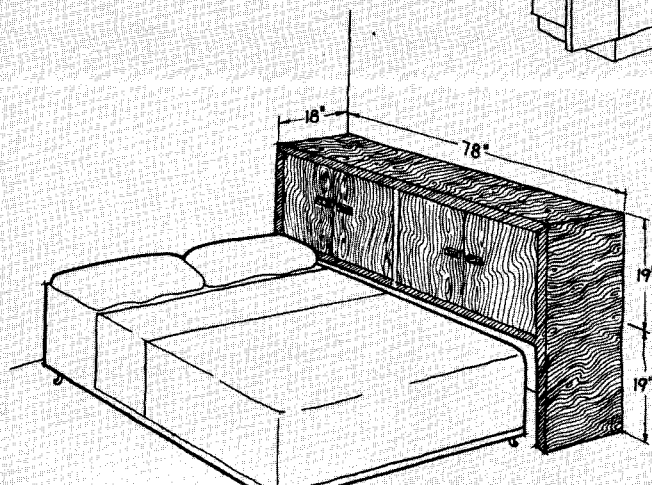

Fig. 4 Wide use of living rooms for regular sleeping suggests need of this basic unit. Made up as couch (left) and as bed (right) unit can be used with either single or double bed



addition, the wall spaces in the living room often prevent the most efficient furniture arrangement. In 2½-room apartments consisting of one large room, a small kitchenette and bathroom, tenant adjustment is even more difficult. Here there is no provision for complete privacy for either member of the family for studying, sleeping or during illness (Fig. 6). In urban communities where living space is at a premium, the architect and the housing manager might well consider "multiple use" rooms as one solution of fitting families into small apartments and still satisfy minimal standards for occupancy, relative to mental as well as physical health. This, however, implies even more detailed study of tenant habits, furniture sizes, location of wall openings, radiators, steam pipes, and so on.

6. Relation of cooking and dining areas

In 31 out of 102 apartments at Red Hook, tenants found it inconvenient to eat in the area designated for eating outside of the kitchen. In many instances, the dining area was too far from the kitchen; this caused too much walking back and forth, and food spillage became a problem (Figs. 7, 8, 13). Others complained of lack of privacy in the dining area adjoining the living room and put up curtains. This cut off a supply of light from the dining area and usually detracted from the appearance of the living and dining area. Still others could not adjust themselves to the new eating arrangement and continued to eat in the kitchen, which had been planned only for food preparation, storage and washing. A general criticism seems to be failure to provide counter space on which to place china and food between stove and table. In most cases this important (from the housewife's standpoint) omission could be corrected by rearrangement of kitchen (Fig. 12).

The question of large or small kitchens can be solved only when more is known about the habits, needs and preferences of the specific group of people to be housed.

7. Storage space

Closet space in some apartments was found to be inadequate, especially since small rooms and broken wall spaces prevented use of storage units such as dressers, chests, etc. This shortage appeared sharply in larger apartments. Tenants in 4½-room apartments found that the smaller of

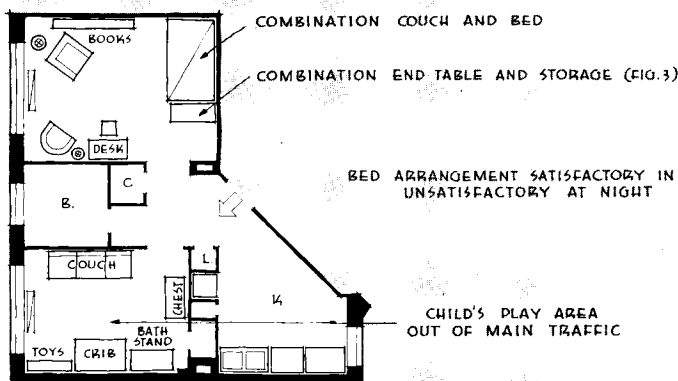

Fig. 5 Parents and 2-year old child. Tenants ignored room labels, made "bedroom" into child's room, "living room" into living-sleeping room. Child has play area, toy storage in own room, thus lightening house work; either parent can sleep on the couch in an emergency

Fig. 6 Young couple. Staff furnished specific advice on furniture purchase and layout, (including designs for bookcases, desk and end table built to order), I.E.S. lamps, etc. Even with dining area, this housewife set up small table in kitchen which "saved her much trotting to and fro." Tenants complained of inadequate food storage in kitchen

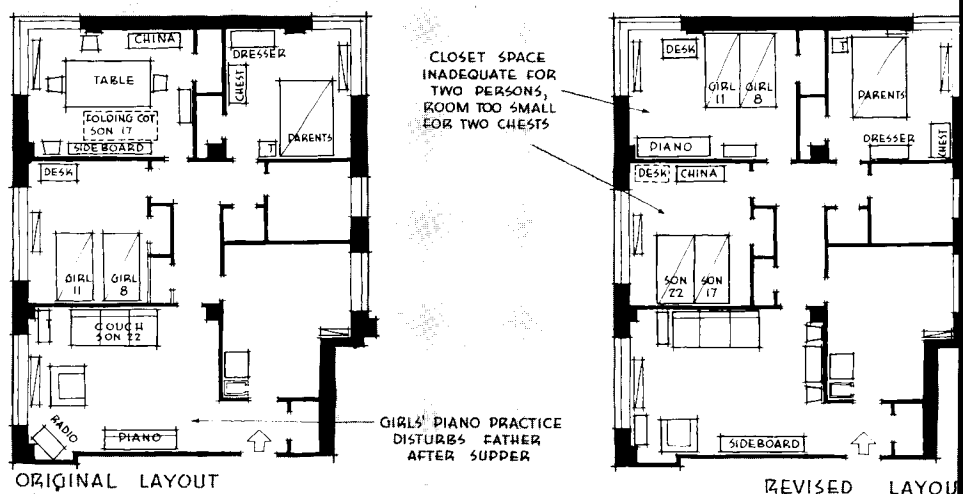

Fig. 7 Parents, two sons aged 22 and 17, two daughters aged 11 and 3. This family bought and arranged the furniture as shown at left: the oldest son, who works, could not sleep well on the couch in the living room; the youngest son, in college, had to sleep on a folding cot in the "dining room"; the parents' bed was placed so that light was disturbing. Analysis showed that the entire family only used dining room about twice a month, otherwise eating in kitchen. By rearrangement shown at right, worst deficiencies were eliminated

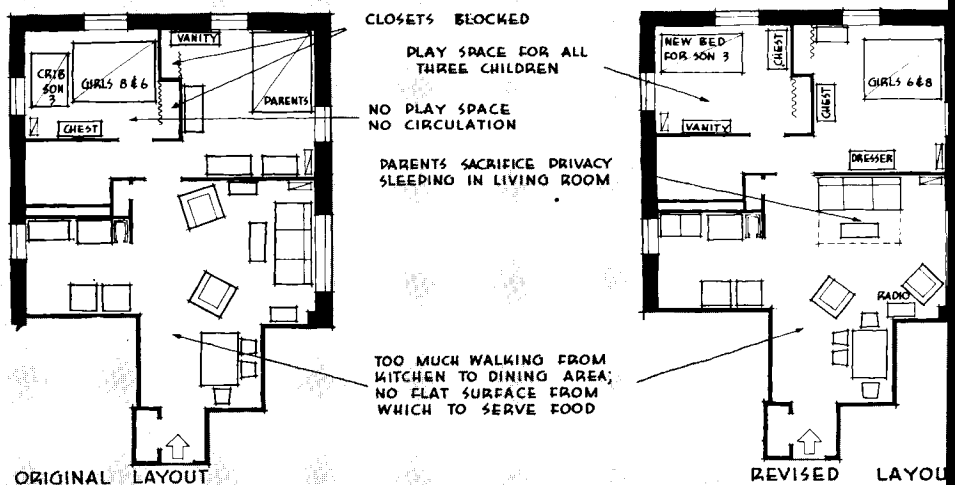

Fig. 8 Parents, two girls aged 8 and 6, son aged 3. Main problems here were crowding, segregation of children, provision of play space. Rearrangement (right) lightened housework but means parents have little privacy, inadequate storage space. Wife was one of many who complained about kitchen, dining arrangements—no serving space, too much walking, etc. Also needed proper space for sewing

the two bed rooms (90 square feet) was not large enough to accommodate a double bed or twin beds, and two storage pieces for the wearing apparel of two individuals who usually occupied this room (Figs. 12, 13). The logical solution would be to increase the size of the room. However, if this cannot be done, it might be possible to use simple built-in storage cabinets (Fig. 3). The cost of this unit might be included in the general cost of the apartment and could be amortised along with the rest of the apartment. This approach to planning becomes increasingly necessary if public housing projects are to admit the low income groups who have difficulty in obtaining even the most essential pieces

of furniture of satisfactory quality.

8. Misplacement of tenants

Several night workers at Williamsburg and Red Hook complained that it was difficult to sleep during the day because their bedrooms were too close to an outdoor play area or noisy street. In future housing developments it might be possible to set aside apartments in quieter locations for night workers or others who might find it necessary to sleep during the day. This is especially true in defense housing areas, where many people work at night and sleep during the day.

The experience of the Interior Design Staff over a period of years indicated the pressing need for a much

closer study of the *social organization of the family*. What activities are to be provided for in multi-family dwellings and by what criteria can they be judged? In the typical American family the following activities constitute the main elements of "home life": sleeping; eating and food preparation; study and school work; relaxation; recreation and play (for children and adults); personal hygiene; child care; care of the sick; maintenance work including laundering, sewing, cleaning (sweeping, mopping, dusting, window washing).

Obviously, the criterion for judging a given dwelling unit will be the *ease* with which these activities can be concurrently or sequentially carried on in it—i.e., *the reduction of friction to the minimum*. While the architect cannot be expected to anticipate the actual and specific needs of each family which will occupy a housing project, he can and should have a general idea of what the *average* family of a given type requires.

In trying to resolve the problems listed above, the Interior Design Staff found that the solutions actually lay at three different levels: (1) Correct utilization by tenant of approximately suitable space; (2) where this proved impossible because of basic deficiencies in a given apartment, transferring the tenant to another unit in the same project better suited to his needs; and (3) *structural* alterations in existing or *plan* alterations in future apartment units to correct both minor shortcomings (window and radiator locations, etc.) and major deficiencies (larger kitchens, more closet space, etc.).

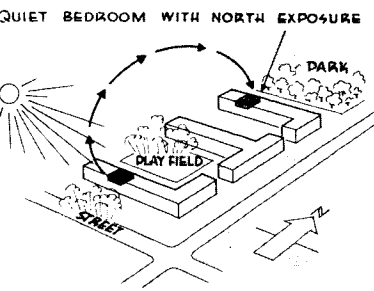

Fig. 9 Southern exposure, noise from nearby street and playground make sleeping difficult for night workers. Solution: moving to another apartment with same layout in quieter part of project; bedroom facing north; top floor to minimize internal noise

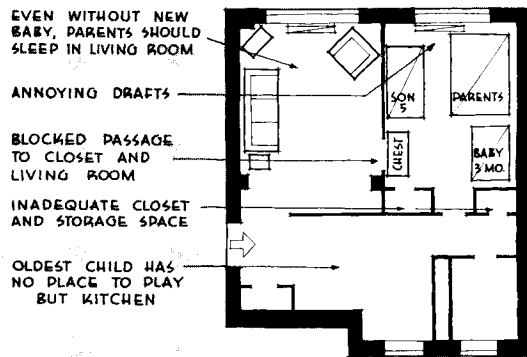

Fig. 10 Parents, son of 5 years, infant of 3 months (born since family moved in). Only solution here would be for parents to use living room for sleeping, bedroom for 2 children. Housewife unwilling to give up new living room furniture still being bought on installment. Family should move to apartment similar to Fig. 8. At time of consultation the Housing Authority had not yet been able to move the family to larger apartment

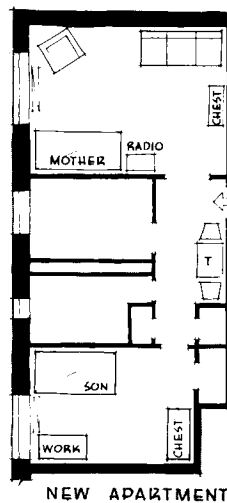
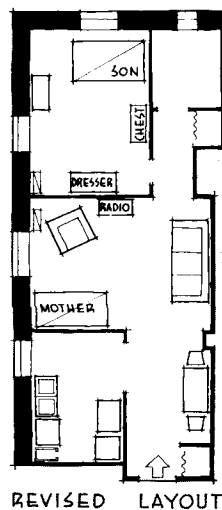
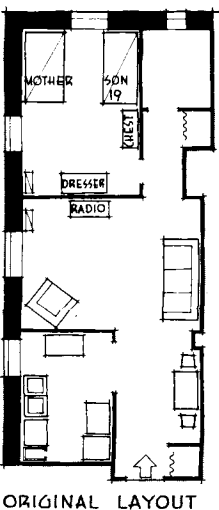

Fig. 11 Widowed mother and son 19. Although suitable for a married couple, the original layout (left) is obviously unsatisfactory. Revised layout (center) calls for mother's sleeping in living room. Privacy is increased and son, who does drafting at night, can have work table in own room instead of in kitchen, as at present. Best solution, however, would be to move tenants to 3 1/2-room apartment with center entrance. This would give both persons privacy for sleeping, work, etc.

(1) Unfortunately, proper use of approximately suitable space implies suitable furniture; and the furniture which most tenants bring with them was found to have important deficiencies in type, size and quality. The Staff found that many tenants brought complete dining room sets—china cupboard, sideboard, buffet, large table, and many chairs—to apartments which had no dining rooms at all! (Fig. 7). Others had bedroom sets—double bed, chest, bureau and "vanity"—which covered 80 per cent of the floor space of the large bedroom (Fig. 8). Analysis of many problems indicated the need for compact convertible couches to serve as an extra bed during illness or for overnight guests. Nearly all the furniture studied was

over-size and not really efficient. This was particularly true of storage pieces. Yet closet space was found to be generally inadequate and inefficient (Figs. 5, 7, 12).

The quality of most furniture was found to be poor—both in construction and design—and disproportionately expensive. Furniture costs present very serious problems to most housing project tenants. Many of the Staff's recommendations could not be carried out because the tenant could not afford to discard old and buy new furniture, while other tenants could only buy from installment plan stores where desired units were seldom available. For this reason, it is essential that simply designed, properly scaled and sturdily built furniture be available. This is especially desirable in storage units; and the Staff has suggested that such basic designs as indicated in Fig. 14 might be considered as part of the apartment equipment—like stove and refrigerator. The cost of such units could become a small monthly item in the rent. The Staff has also suggested some basic designs for low-income urban families which might be considered by furniture manufacturers (Figs. 1 to 4)

(2) The second type of problem the Design Staff found was that of tenants who—for one reason or another—had apartments which were simply unsuited to their needs. This problem usually involved family *composition* rather than family *size*. Thus a childless married couple can use a 2½-room unit as planned (Fig. 6) while a mother and her adult son can only do so by using the living room as a bedroom. Even then, there would be no privacy for the person sleeping in the living room unless entrance to the apartment was in the center (Fig. 11). Person-per-room ratios do not reveal factors of this sort. Again, the Staff found several instances of night workers whose apartments would have been satisfactory except that *their location near a noisy street or play field made daytime sleeping difficult* (Fig. 9). Births and deaths in the family pose the need for more or less space or for a different organization of it (Fig. 10).

The solution in such cases would obviously have been to move the tenants to other apartments in the same project whose layout could be better adapted to their needs. This leads to the conclusion that all projects should

have a supply of "spare" apartments of various sizes and types to permit adjustment. Advanced housing groups have long recognized this as an important consideration.

(3) The Interior Design Staff observed many instances of apartment deficiencies which could be corrected only by structural alterations to present apartments or redesign of future

ones. Some of these were of a minor structural nature, although often causing important difficulties in furniture arrangement. Among such features were window, radiator and steam pipe locations (Figs. 12, 13), lack of serving counters between kitchens and dining areas (Figs. 8, 12), location of bathroom window over tub, etc. But others involved major changes in

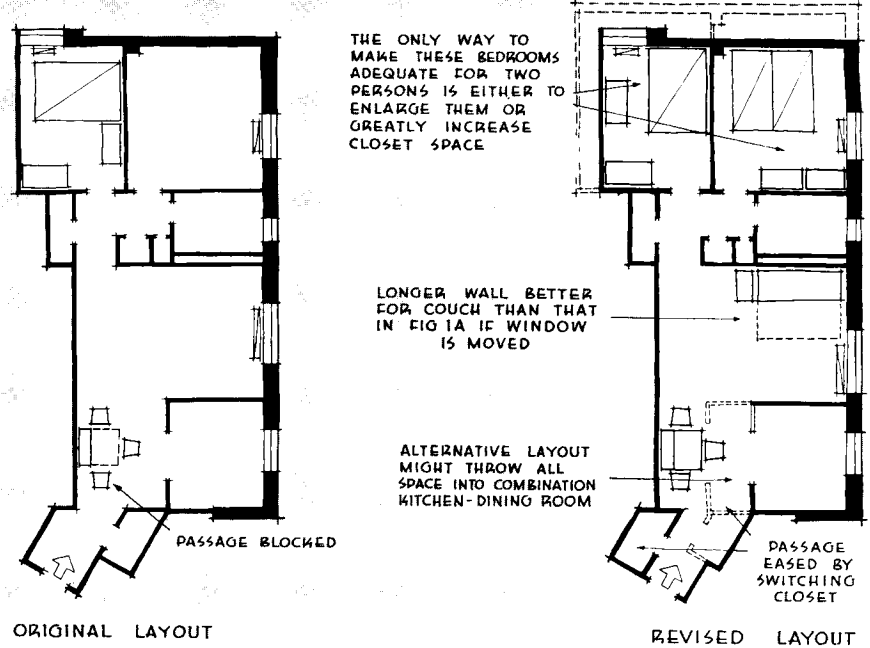

Fig. 12 As analysis showed, families consisting of parents and 2 children usually occupied 2-bedroom apartments. Thus both bedrooms are actually used by two persons. Sex and age permitting, larger bedroom logically goes to children, since play space here keeps them out of housewife's way elsewhere. But smaller bedroom (90 sq. ft.) is inadequate for twin or single free-standing beds plus necessary storage pieces. Solution: enlarging both bedrooms or doubling built-in storage space or both

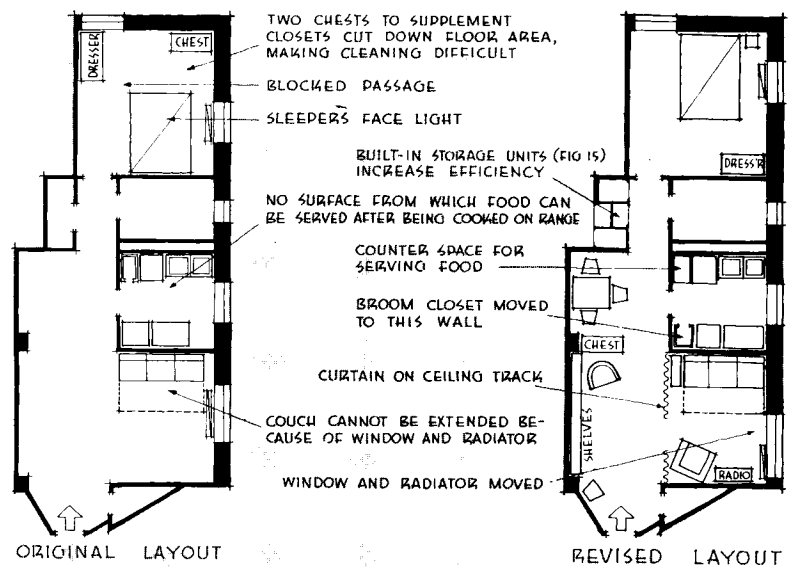

Fig. 13 If an apartment of this size is occupied by a married couple, the layout is fairly satisfactory — though tenants complained about lack of counter space between range and dining table. But in case of illness or visitors, living room window and radiator prevent extending couch. If family has a child, need for sleeping in living room raises question of privacy and additional storage facilities. Furniture layout makes bedroom difficult to clean; only structural changes such as indicated (right) will correct

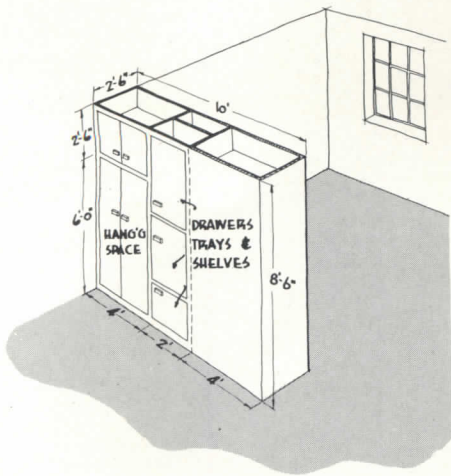

Fig. 14 Built-in cabinets such as this instead of closets would greatly increase storage capacity and thereby free floor area, as well as reducing the amount of furniture which tenants would need to buy

plan and construction. Among these were poorly planned closet space and bedrooms whose shape, size and wall space would not permit sufficient storage units (Fig. 12); and lack of privacy in living rooms which should have been slept in—either regularly or during illnesses.

Perhaps the most basic and at the same time most general shortcoming of all apartments was not so much the quantity as the *quality* of the space provided. The ordinary unit of measurement—so many sq. ft. per room—does not adequately express this important factor. A space 4 x 30 ft. has the same floor area as one 10 x 12 ft., yet the quality of the two is obviously different. It is this phenomenon which has led the Hygiene of Housing Committee* to observe that “although a dwelling may have been planned in a most efficient way to allow space for the proper placing of furniture, circulation, and even privacy, it is nevertheless possible that there will be a feeling of discomfort and of space-crowding. There is no scientific evidence to prove that this will result in mental ill effects; however, in view of the frequently expressed desire for more space, it is important to pay attention to this problem. It is an established practice to consider a site plan in terms of its coverage by buildings and to set standards of 25 to 30 per cent coverage. Perhaps a similar approach might

*In the report cited.

be used with regard to floor plans; at least it would be instructive to analyze some of the existing designs with regard to the floor area covered by furniture.”

How can the architect get this information?

If dwelling design is to improve progressively, studies must be carried on at existing housing developments to determine to what extent the houses meet people's needs. This type of work might be facilitated if the families participate in these studies, possibly through schools, women's clubs, community clubs, tenant organizations, etc. Some of the techniques which might be used are: to set up classes in home planning at housing developments or nearby schools and have the class gather the desired information and evaluate their own dwellings in the light of standards which have been set up; another is to set up a tenant service at the housing development which, in the course of its work with tenants, will learn more about the nature of tenants' problems, and can thus provide data by which the efficiency of apartment layouts can progressively improve.

WHAT EVERY ARCHITECT SHOULD KNOW

1. Standards for distribution of living and working space: The architect must be familiar with the satisfactory standards for such functions as:

- (a) sleeping relative to age and sex differences, requirements of old people.
- (b) eating relative to circulation, privacy, convenience and accessibility from the food preparation centers, the habits and preferences of the families.
- (c) recreation, rest and play relative to privacy, elimination of outside disturbance, storage of playthings, space requirements, orientation of windows. Supervision of children is also an important consideration when children are young.

2. Standards for arrangement of furniture and equipment within a given space, for example:

- (a) location of beds in terms of proper lighting, ventilation, circulation, and privacy.
- (b) location of homework centers in terms of adequate space, lighting, elimination of disturbance, privacy.
- (c) location and arrangement of play areas in terms of adequate space, storage units, privacy, safety, and (in some instances) sunlight.
- (d) location and arrangement of reading, relaxa-

tion and radio listening centers in terms of good radio reception, elimination of disturbance, circulation.

- (e) location and arrangement of social centers for entertaining, bridge parties, sewing circles, discussion groups.
- (f) location and arrangement of kitchen work centers in terms of the interrelated family activities which go on there. For example: the housewife may have to keep her eye on the very young children while she does her kitchen work; or she may want someone to keep her company when the meal is finished and she is washing the dishes.
- (g) location and arrangement of furniture and equipment in the bathrooms and laundry centers.
- (h) location and arrangement of storage space.

3. Standards for the design of furniture and equipment: The architect should know enough about designs of existing furniture and equipment to understand how well they meet the requirements of everyday use. This will make possible not only improvement in housing design but a parallel improvement in design for furniture and equipment.

THE FIRM OF SHREVE, LAMB & HARMON

A first-hand account of how an outstanding office is organized and how it operates. . . . It's the first of several similar stories presented to give a behind-the-scenes picture of America's architects in action and to report the personnel, policies and procedure that make for success in day-by-day office operation.

By HENRY H. SAYLOR, AIA

All photographs by the author.

ARCHITECTURAL OFFICES are something like the cells of living tissue. Cells double up and split. Where there was one today, two may exist tomorrow. A famous firm of New York City was such a cell. One day it was Carrère and Hastings; the next day it was Carrère & Hastings, Shreve & Lamb; shortly afterward it became two offices instead of one.

It was in 1924 that the inevitable split occurred. Among the more sizable jobs in the office were the Fisk, Macmillan and Standard Oil buildings. Upon the insistence of the clients, these works were completed under a temporary association of Carrère and Hastings and the new firm of Shreve, Lamb and Blake. Theodore Blake subsequently returned to the C. and H. fold, and five years later Arthur Loomis Harmon joined the firm of Shreve & Lamb.

Each of the three partners has achieved distinction as an individual, entirely apart from the firm's outstanding reputation. Each has been elevated to Fellowship in the Institute.

Richmond H. Shreve had been two or three years late in entering Cornell to study architecture, due to his having had to go to work after high school days to earn his tuition expenses. This work was in an architect's office and brought a sense of values that made up for the delay.

After his four-year course Shreve's appetite for graduate study was satisfied through Cornell's offer of an instructor's job. He also prepared illustrations for a textbook on shades and shadows. Even then, time hung heavily on his hands until, at the suggestion of the faculty, Carrère and Hastings made him clerk of the works for a million dollars' worth of buildings they were erecting on the campus. Just how one man could pursue graduate study, instruct fresh-

men in the graphic arts, and hold down a full-time job of clerk of the works is not clear, but Shreve did it. The Cornell buildings finished, Mr. Carrère asked him to join the New York office. By 1920 he had become a partner.

Mr. Shreve was Chief Architect of the Williamsburg Housing Project, and of the Vladeck Housing Project, each carried out by a group of associated architects. For the New York World's Fair, he served as a member of its Board of Design. He is at present Chairman of the Board of Design of Parkchester, Metropolitan Life's big residential community. His outside activities include the past-presidency of the New York Building Congress and membership on the Advisory Board of Architects of Goucher College, Baltimore, and on the Advisory Council of the College of Architecture of Cornell University. After serving two terms as Regional Director of the New York District, AIA, he was elected President of the Institute last May.

William F. Lamb was graduated from Williams College before he elected to follow architecture. In his first summer after graduation he served as an office boy for the architectural office of Frank Helmle, probably at the foot of his class in earnings—three dollars per week. Two years of the architectural course at Columbia would ordinarily have been considered hopelessly inadequate preparation for the Ecole des Beaux-Arts, but after that short period of training Lamb was admitted to the Paris school as top man among those attempting the entrance examinations.

After four years he was awarded the coveted *Diplome par le Gouvernement Francais*, returned to New York and at once entered the office of Carrère & Hastings. By 1920 he also had become a partner in the firm

then styled Carrère & Hastings, Shreve & Lamb.

For three years — 1937-9 — Mr. Lamb was the hub of the World's Fair Board of Design. He coordinated the work of all the outside architects and directed the design activities of the Fair's Board of Design. President Roosevelt made him a member of the national Commission of Fine Arts, a post which he now occupies. For the City of New York he served as a member of the Art Commission. In 1932 Williams College honored him with the degree, Doctor of Science.

Arthur Loomis Harmon was born in Chicago, earned his way through a year of architectural study at the Armour Institute and the Art Institute. The combination did not seem to be giving him the training he sought, so he came to New York and entered the architectural school at Columbia in the fall of 1898. This should have brought him to graduation in 1902, but he beat the gun by a year and went back to his home town. The summers between terms had offered little time in the way of vacation. In one of them Harmon worked as a carpenter on a house that the late Frank Wallis had designed in Montclair.

Back in Chicago, Harmon saw the inside of several offices—Holabird and Roche, D. H. Burnham and Company, Howard Van Doren Shaw, Benjamin Marshall. But the lure of New York beckoned and Mr. Harmon came east in search of a new connection. Walking along the street, he met William Partridge who invited him up to help render the reconstructed L'Enfant plan of Washington in the McKim, Mead & White office. It proved to be a nine-year tenure in that distinguished organization, interrupted only by travel and a look at the architecture abroad. For two



SENIOR PARTNERS: top, Richmond H. Shreve; center, William F. Lamb; bottom, Arthur Loomis Harmon

years he practiced in association with Wallis and Goodwillie, then on his own until he joined Messrs. Shreve and Lamb in 1929.

Mr. Harmon is a past president of the New York Chapter, AIA, and also

of the Architectural League of New York. He is a member of the National Academy of Design and the Fine Arts Federation of New York City. In 1925 The League awarded to him its Gold Medal for the Shelton Hotel,

and that same monument brought him the Gold Medal of the American Institute of Architects.

So much for the individual backgrounds. In view of these, it is rather surprising to find the office of Shreve, Lamb & Harmon an example of closely welded teamwork. Three such vigorous personalities do not often find it possible to merge their efforts in a comfortable collaboration, year in and year out.

How do the wants and needs of a new client become translated into working documents and a completed structure? Sometimes all three of the partners are in on the first conferences, occasionally only two, but Shreve is pretty sure to be one of them. From this point the development of the design usually becomes the personal responsibility of either Lamb or Harmon until the preliminary drawings are made, a scheme accepted and the work put into the hands of a job captain to be executed. Both Lamb and Harmon refuse to be cheated out of the fun of putting a scheme on paper with their own hands. In the private office of each, drawing-board, T-square and triangles are in front of the principal's seat. Letters, memoranda and other impedimenta may cover them for a while, but the actual tools of design are never put aside.

The office is conducted on the job captain plan, but rather more so than usual. A job captain, having been given the accepted preliminary sketches, not only makes the working drawings, aided by his crew, but writes the specifications and supervises the job. He is the one man who is expected to know all about the job in his care. Having been with it daily and hourly since its inception, he does know it, else he would not be holding the job captain's table. A man out of an architectural school usually serves seven or eight years before he achieves a job captaincy.

In this procedure, specifications take form with the drawings instead of being written afterwards, thus avoiding the inevitable risk of gaps in conformity. Matters of design are subject to the constant supervision of either Mr. Lamb or Mr. Harmon, sometimes of both. Although Mr. Shreve leaves the evolution of a design pretty much in the hands of whichever partner is controlling it, he is likely to step into the batter's

box when presentation drawings are about ready for submission to the client. When he does, his criticism is usually aimed from the client's point of view. He will question the workability of the building rather than a detail of esthetics.

A distinctive feature of the Shreve, Lamb & Harmon office is its Operating Committee. Four persons constitute its membership. In effect they are junior partners. Their names appear on the building's directory, on the letterhead and as individual listings in the telephone directory, and in addition to their salaries they participate in the profits. Every Thursday the four lunch together in a private room at a nearby restaurant, discussing ways and means of conducting the office more efficiently, allocating tasks and supervision among themselves, counseling upon "hiring and firing." The extent to which these administrative efforts relieve the three partners from routine and free them for more creative work is one of the conspicuous characteristics of the organization.

Three of the four Operating Committee members pioneered with the young firm of Shreve & Lamb when it stepped out on its own from under the Carrère & Hastings banner: H. F. Vanderbeck, Margaret Livsey and H. R. Dowswell. H. C. Bernhard came out of Cornell, the son of an architect now retired but for many years architectural engineer of James Gamble Rogers' office. Before he had had time to orient himself in the S. L. & H. office Bernhard found himself in charge of the Reynolds Tobacco Company Building, a two-million dollar project in Winston-Salem. Neither he nor the building came out of it any the worse for the shotgun marriage, and Bernhard has been job-captaining ever since. It was about three years ago that he was made a member of the Operating Committee.

Vanderbeck began as an office boy in Carrère & Hastings' office. Today he is a revered master of preliminary drawings. They say he can knock out a set of sketch plans almost before Mr. Lamb or Mr. Harmon finishes explaining to him a tentative *parti*. Another branch of the office practice that inevitably falls to his hand is tenant space—the design or remodeling of leaseholds in office buildings the firm has built. That sort of work, incidentally, is the nearest approach



OPERATING COMMITTEE: left to right, H. F. Vanderbeck, H. R. Dowswell, H. C. Bernhard and Margaret Livsey

to a backlog in the firm's practice. In good times and bad it keeps rolling along.

Miss Livsey was one of Shreve's assistants in the C. & H. office and is, according to him, his "boss." She has added to her jobs that of confidential secretary, the hiring, training and managing of the clerical accounting staffs, and the correlation of all and sundry information and records of the firm's activities. I suspect she knows more of what is going on in the wide orbit of the office than any other single individual, and I am quite sure that she knows enough to pass through to R. H. S., W. F. L. and A. L. H. only what it is good for them to know. An after-hours visitor to the office, awaiting one of the staff, regretted the fact that he had encountered no member of the firm; but he had been much impressed by the activities of "Mrs. Shreve, Lamb & Harmon."

Dowswell has made a national reputation for himself as an all-round technician and specification writer.

No individual in the S. L. & H. office has a secretary. There is a secretarial pool of highly trained girls—five at present—who work in very close collaboration. Any one of them is subject to call by the partners, associates and job captains. The obvious objection that in this system no one girl becomes familiar with all the names and personal relationships involved seems to have been overcome by unusually close teamwork of the five and their long service together. Correspondence files and library are in charge of a file clerk who is also a trained librarian. Ac-

counting, bookkeeping, telephone and reception work are done by persons expert in each special field rather than by members of the general secretarial pool.

Down the lefthand margin of the draftsman's weekly time sheet are printed the office regulations. Hours are 9 to 5, with the hour between 1 and 2 for lunch. Draftsmen register their arrival and departure at the reception room desk. Extra time and make-up time are recorded on special daily tickets and require the approval of the job captain. Persons employed for six months or more are entitled to half pay for sick time, up to two weeks in any one year. After the first six months of employment, vacation time is earned at the rate of one week for each six months prior to June 1st of any year. The drafting staff is on a five-day week the year round; the clerical staff, a 5½ day week.

Unlike some of the large offices, this one believes in enlisting the services of outside structural and mechanical engineers rather than maintaining its own. Of course, with long-experienced master builders like Dowswell in the place, the office needs no outside help in figuring steel or sizing pipe for the ordinary job, but they usually call in engineers with whom they are constantly collaborating, to do the job more quickly and without the cross-checking the regular staff would feel was needed in this less familiar work.

Several contract forms are used by the office. Those calling for cost plus a fee are drawn after the pattern arising from the firm's experience. For lump-sum contracts, the AIA long or

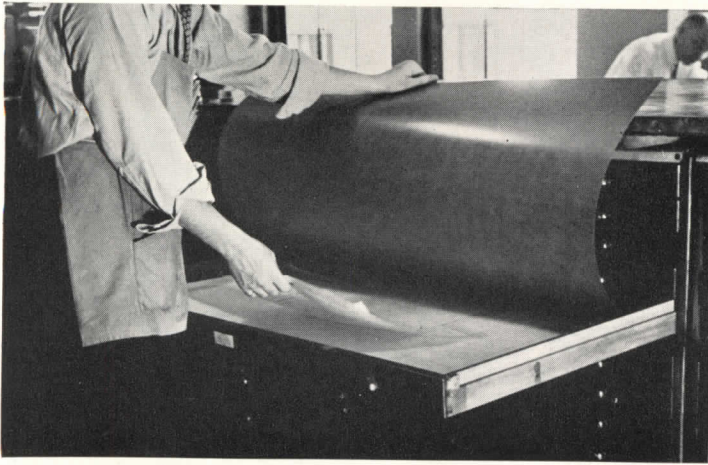

Drawings for active jobs are filed flat

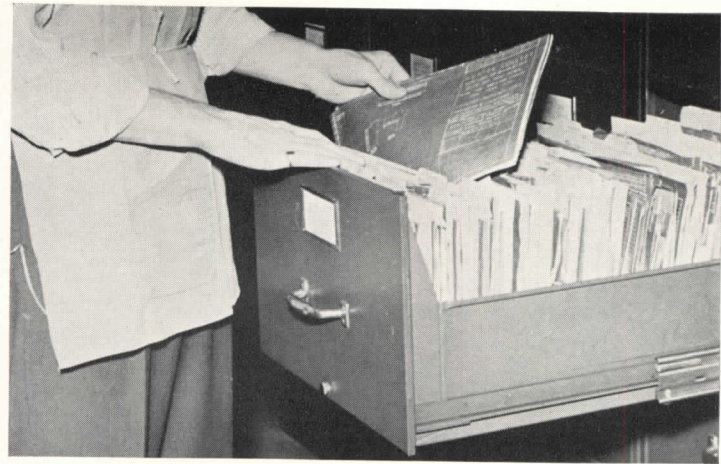

... and shop drawings folded to legal size

short forms are used as a general rule.

Change orders are made out in quadruplicate, and must originate in the contractor's office. Each is a proposal of the contractor to do a certain piece of work for a specified sum. The original, when approved by both architect and owner, is sent to the contractor; copies are retained by owner, job captain and auditing department.

Minutes are written covering all meetings of owner's representatives with architects and builders, listing those who attended and setting down the findings agreed upon. Decisions made by the firm, the associates or job captain are invariably put into memorandum form and filed as a documentary history of the job.

The system of numbering drawings

is helpful. In addition to the job number, a working drawing will bear a combination of four digits. The first two digits, from left, give the classification as to materials, 20 being reserved for the general plans and elevations. The final two digits become more specific. Thus 2001 is the first floor plan; 2006, the sixth floor plan. Scale details of first floor plan would take the number 2011; full-size details of first floor would be labeled 2021. Numbers below the 2000 are for preliminary drawings in order of production. A number starting with 21 indicates that it is concerned with excavation; if with terra cotta it starts with 34. Each category of construction has its regular number, ranging from 21 through 55. Thus the number of a drawing alone is sufficient to identify

its purpose, and the subtitle becomes unnecessary.

Each working drawing bears, along its righthand edge, a table in which is entered each successive revision, if any, and each issue of prints. A glance at this tabular matter on any original will show when prints were issued, to whom, and the package number under which they were sent out. Drawings are kept flat in drawers between pressboard guides while the job is active, then rolled in a large tube, indexed and stored.

Sheet sizes of working drawings are established for each job by the size of plans and elevations at the desired scale with regard for stock widths of linen. Once established, this sheet size is maintained throughout the job. Drawings are made in ink on linen in cases where much blue-printing is anticipated. Government jobs require it in all cases. Full-size details requiring few prints are made in pencil on paper. Minor jobs are occasionally drawn in pencil on linen, or even on paper.

Shop drawings are received in duplicate; one is returned with approval or corrections, one is folded to legal file size and filed under category guides and job number with the drawing file clerk. It is an unwritten rule of the office that each shop drawing submitted is returned with approval or corrections within five days.

Every drawing or print that leaves or arrives at the office is recorded by the clerk in charge of the file. Prints going out are accompanied by a transmittal form typed in triplicate: original with the prints, duplicate to the job captain, triplicate to the drawing clerk's file. This specifies the



Drafting room of the Shreve, Lamb & Harmon organization

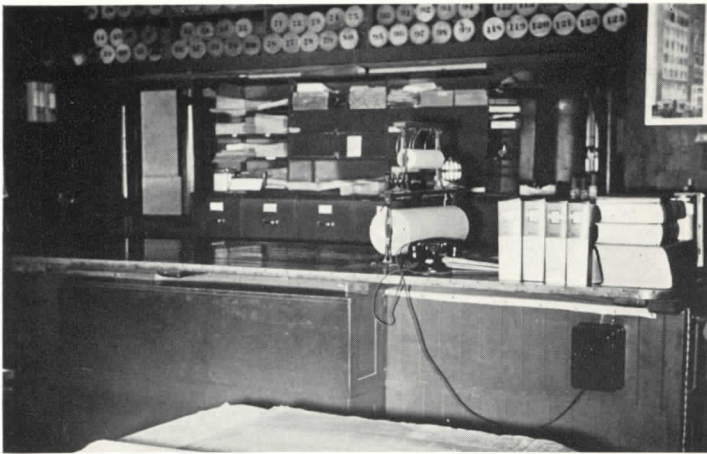

File Clerk's desk where all drawings are checked in and out

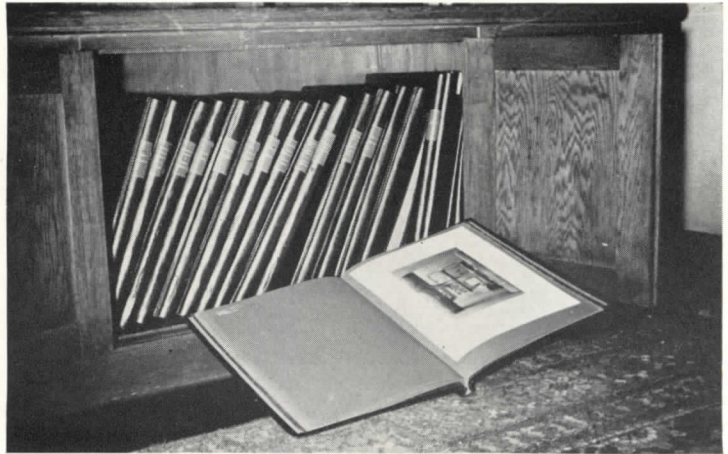

Photographic records of completed jobs are uniformly bound for reference

drawing by name and number, to whom it is sent, and for what purpose.

The lads who are entrusted with these files usually step up from the office boys, and these are selected with far more than the usual care. Most of them come from the Brooklyn Technical High School's architectural department. To qualify, a boy must have ambition to become an architect, and a conviction that he has a long and hard road of study ahead. The office gladly pays half the cost of night-class schooling he will undertake. Ten or twelve of these boys have put their feet on the ladder; two have gone on up to Cornell; four or five have studied at New York University.

Recalling their own early days and the awesome difficulties of getting a start, the firm established some years ago the Shreve, Lamb & Harmon Fellowship at Cornell. Each year the faculty selects from the senior class in the architectural school a man whose record and personality deserve this recognition. He is welcomed to the office on a year's contract at a salary that will support him comfortably in New York. In that year the organization tries to acquaint him with every branch of the work, including outside supervision. It is an ideal arrangement for the fledgling, giving him every opportunity of finding the particular niche his tastes and capabilities indicate. At the end of the year he will either have shown that there is a place for him in the organization or will seek new fields.

A subject on which I sought information was the march of new products and techniques. How does the office keep abreast of these?

Messrs. Dowswell and Bernhard try to see every salesman who calls and hear his story. Catalogues and data sheets that he may leave are filed in the regular AIA file, and it is an extensive one. Advertising matter which arrives by mail is routed by Miss Livsey to Mr. Bernhard who indicates what is to be filed and what destroyed. For the sake of convenient and economical filing space, all hands plead for the standard $8\frac{1}{2} \times 11$ in. size in manufacturers' literature.

New materials and methods that impress Bernhard or Dowswell are shown to S. L. & H. partners for the effect these products may have upon future basic design.

Current magazines are routed to the partners and associates, each marking pages that he wants clipped and filed. These clippings—or sometimes whole issues—are gathered into

portfolios covering a wide range of subjects, and stand on the library shelves, accessible to any of the staff. In the office library stands a row of tall portfolios, each a photographic record of an architectural achievement in the firm's less than twenty years of practice.

At the moment the large drafting-room is only sparsely occupied with active boards. On two lower floors, however, are large rooms filled elbow-to-elbow with draftsmen and engineers busy with plans for the Army's Newfoundland Outlying Defense Base. And the name on the doors is "Shreve, Lamb & Harmon, Fay, Spofford & Thorndike, Architect-Engineer." The Newfoundland Base job, like Trinidad and Bermuda, was awarded to the architect-engineer combinations on the basis of cost plus a fixed fee.



NEWLY ELECTED PRESIDENT OF THE AIA

RICHMOND H. SHREVE, with a bent for "order, forethought and system," discusses architectural practice and the trend of a changing professional field.

TWO invitations were important factors in the professional life of R. H. Shreve. The first, extended by John M. Carrère in the course of a warm friendship, invited the young man to leave his instructorship at Cornell and enter the Carrère & Hastings office. The second, offered with some heat by Thomas Hastings, invited Shreve, then a partner in the firm, to leave the office within 24 hours. Shreve accepted the first and declined the second.

While Carrère was debating whether to put the new employee, brought down from Cornell, on the New York Library job, or on a large country house, Shreve roamed the office, seeking what he could devour. The mail seemed a promising tidbit, so he opened and routed it. A new sort of indoor game was soon evolved. Shreve played it with himself as opponent. He would study in advance a

letter that needed J. M. Carrère's decision; the match was lost when, on reading the letter, J. M. asked some question that Shreve couldn't answer. On the other hand, if all the contributing documents and other facts could be assembled beforehand, to forestall any question J. M. might ask, Shreve won that match. He spent a lot of time and thought preparing himself to win those matches, and his scoring must have improved rapidly.

Looking at the events in retrospect after these many years, it seems highly amusing to see an unabashed youngster sneak up behind that particular old-school silk-hat firm, with slide rule in one hand and a sheaf of plotted curves in the other, and finally having the organization eating the contents of both his hands, and liking it.

If you were to suggest to Shreve that his contribution in the work of his firm seemed to be more closely connected with the business administration than with the esthetics of the joint effort, he would pull out of his desk drawer a bronze medal once awarded him for excellence in architectural design. His election to a Cornell honorary society, based on scholarship, meant far less to him, I imagine, than the fact that Olaf Brauner had framed one of Shreve's life drawings and had kept it at the college for the 34 years he remained on the faculty. Nevertheless, if one starts him talking about Empire State or Parkchester, or the Newfoundland Defense Base, he will spend more time upon the operations chart than upon the detail drawings. It will pain him just as much to recall that the plumbing subcontractor was three days late on the schedule, as that a grille which might have been bronze had to be cast iron.

Order, forethought, system are words that might be his middle name.

Shreve knows how to play as well as how to work. His chief relaxation is in the north woods. One would hardly expect him to relish the comparative quiet and slow motion of the fisherman, yet he is a particularly skillful one. These excursions, usually into the Hudson's Bay country, however, are as Shrevian as his office routine. They are planned ahead and scheduled almost to the hour. Barring interference by acts of God, his party will emerge from the woods to entrain at the hour and day scheduled, and will have covered every mile of watercourse, every foot of carry, every hour specified for hunting or fishing as set down on the program months before. Shreve went around the world a few years ago, and the single deviation from his schedule was occasioned by the premature death of a man he was to have met for lunch in Bombay.

It has been said of Shreve by an intimate friend that his favorite sport is playing chess with men rather than with carved markers. He loves to telephone someone, suggesting action along a line he has plotted in his imagination. Then, sitting back in his chair, he pictures the action proceeding here and there about the city, like sparks along a time-fuse, until the telephone rings to let him know that the last event in the train has occurred and another one of those games with himself has been won.

Shreve's memory is of the file-index type, with every significant fact, every illustrative anecdote, put away in a slot from which it can be instantly withdrawn for use. When he speaks in public, his words are suave, temperate, and so orderly an expression of thought as to suggest that they have been dictated, typed, reread, corrected and retyped—all in the process of being uttered. A listener is inclined to mutter impatiently to himself, "Why isn't he dogmatic about it?—any fool can see he is right."

ACTING upon the feeling that the new AIA president's thoughts would interest the profession, I put to him some pertinent—perhaps impertinent—questions.

What is the architect's future? Is he being displaced? What is the Institute's program? Is practice by bureaus likely to keep on increasing? Would you advise your own son to follow architecture under today's conditions?

"For one thing," said Shreve, "it seems not quite fair to demand a new and militant Institute program from one who has been president a bare two months, and who, looking into the Institute's cash-box, finds it needing careful nurturing. Nevertheless, there are earnest and conscientious men working in committees all over the country, and I'm cooperating with them at every point. We shall have something to say on Institute matters before very long.

"I will say this. The Institute has probably been too much of an *indoor* activity, deeply concerned with organization procedure, with precise and beautiful accounting systems, with the conduct of meetings and with admission requirements. One of its chief concerns has been to find a clear legal path among its own entangling by-laws. A lot of this indoor sport will have to be given up as the Institute gets out into the open air, breathes deeply and tackles the new problems of a changing professional field.

"If your question as to the architect's future means, is he going to see soon again the lush days of the 20's, the answer is 'Not soon.' The sort of practice we look back upon with yearning had for its principal element a rich man. Rich men built great manor houses, college memorials, art museums. They made possible the costly churches, university stadia. Such commissions will appear less frequently.

"The signs are fairly clear, it seems to me, that whatever is in store for us as a nation—and he would be a rash prophet who attempted to blue-print it—we are not going to be overburdened with rich men turning their surplus wealth into impressive personal architectural monuments.

"The whole trend of the times, insofar as we can see it, is towards a leveling off of our national economy. That must mean building with rigidly budgeted funds for the services of necessity—national defense first, and a lot of its blood brothers following after for some time to come.

"That calls for an attitude of the architect very different from that of 'the good old days.' Those who look backward in a nostalgic dream are likely to go hungry.

"To say that designers are coming to be less in demand and will go out like the dodo, is to talk foolishness. Plain common sense should tell us that the technician, whether in building or any other activity of mankind, is more and more needed as we settle down to a community life founded by necessity on economy of structure and precise fitness to new needs. Buildings in that category do not get themselves built—they have to be designed with all the skill mankind can muster!

"I doubt that we shall see in the next decade or more the architecture of pride, of display, or of self-gratification. But we shall undoubtedly see outdated, inefficient, uneconomical structures torn down to make way for new and efficient and economical buildings, in tune with the time and meeting our constantly growing needs.

"Would I urge a son of mine to follow architecture today? Well, I haven't done so with my three, because they made their own well considered choices—medicine, administrative and mechanical engineering. But I see no reason whatever for looking upon architecture as a dimming prospect if the youngster realizes clearly that he is not entering upon a glamorous future of merely painting beautiful compositions in pigments of wood, steel, glass and concrete.

"Another thing: the hallowed six or eight or ten or any other percentage of the cost as an equitable fee is being challenged. It was a workable basis of remuneration from the rich patron of the arts. Today, government, state, municipality are becoming harder buyers. They think—and those who direct big business are likewise coming to think—that a highly skilled technical service can more accurately be measured in comparison with other skilled services of the individual in terms of yearly income, entirely dissociated from the necessary costs of assistance and overhead. The cost-plus-a-fixed-fee contract, such as the Government has put into effect, is likely to change the nation's thinking in the matter of architects' remuneration. Those who think of architecture merely as an art may regret, but cannot stop, the trend.

"Architectural education, like all other education, is facing readjustment. Colleges and universities used to coast along on income from endowments. Today this income is materially decreased, with no prospect of a turn upward. We can hope that endowments may be increased by the beneficence of our disappearing rich men. Otherwise education must cost the student more. Defense demands upon youth mean fewer college students for a time and more cost per student. All this threatens to whittle down the education we are going to get—probably at a sacrifice of arts and letters and a greater emphasis on specialization in techniques.

"The Institute proposes to face these professional problems realistically and earnestly."



MACDONALD HOSPITAL, Warsaw, Indiana. A. M. Strauss, Architect

HOSPITALS

A BUILDING TYPES STUDY

- FOR DEFENSE

- PSYCHIATRIC

- GENERAL VOLUNTARY

FOR THE FIRST six months of 1941, total floor area provided and valuation of hospital building are slightly greater than for the corresponding 1940 period, according to F. W. Dodge statistics. The number of individual projects, however, is almost three times as great. This is due to several factors, of which probably the most important is that many of the projects are in army cantonments. Each camp requires many hospital structures ranging from blister clinics to operating suites, including administrative, service, recreation, and ward buildings. Completely equipped infirmaries and nine general hospitals located in various sections of the country, totaling more than 45,000 beds, testify to this type of activity. At Fort Bragg in North Carolina, where the total construction bill was over \$32¼ million, 204 hospital buildings cost more than \$2,800,000. This is perhaps an extreme case. In Fort Leonard Wood, for example, 20 hospital buildings cost approximately \$435,000.

What other kinds of hospital building are going on, and what seem to be in prospect? *Modern Hospital* reports that of 465 non-military hospital building projects surveyed, 95 were new hospitals, most of them costing

\$100,000 or less. Additions and alterations totaled 289, almost equally divided between those costing less than \$100,000 and those of more than \$100,000 valuation. Nurses' homes, new and remodeled, totaled only 38 projects.

This emphasis on rejuvenation of existing non-military hospital plants is logical. By the time a hospital is 20 or 30 years old, there are 72 chances out of a hundred that it will be modernized or replaced. Out of a thousand such hospital projects surveyed, more than half of the replies reported renovations; a little over 10 per cent had demolished old buildings to make way for new ones. A hospital's life does not usually exceed 40 years—2½ per cent of all hospitals are replaced each year. Such institutions are expensive. Costs of new buildings have to be carefully weighed against modernizing costs.

Hospital administrators cannot let their plants remain static. The public reads of a new treatment; the doctor sees greater possibilities if his facilities are improved—and soon the hospital building is obsolete or remodeled.

Nor do mere additions suffice. More clearly than in most building types, the ultimate hospital function demands a closely integrated set of services—food, heat, laundry, sterilization, to name a few. These have to be expanded or changed as more bed space, or a new department, is added. Expansion entails much rearrangement of the entire plan.

Three persons are commonly associated in a hospital project: the hospital administrator, the architect, and the consulting specialist. Occasionally the administrator or the architect assumes the consultant's job. But the administrator is the only person who can be expected to know intimately all the conditions under which the work will be prosecuted. It is his job to inform the architect, with the object of assuring production of a smooth-working hospital design.

The consultant is most often an administrator or ex-administrator whose talents and experience fit him to advise either on special problems or on the job as a whole. His abilities are much in demand; in this highly organized field his role is often as important as the architect's.

MILITARY HOSPITALS ARE



ON THESE AND THE FOLLOWING TWO PAGES we treat a subject which has an immediate practical value—planning PAVILION HOSPITALS. Illustrations are of military hospitals in this country and abroad—subjects of timely interest. Principles of planning for pavilion structures are equally applicable to many peacetime institutions: to hospitals for treating tuberculosis, some forms of insanity, and even to certain types of hospitals for chronic patients. Welfare Island Chronic Hospital, in New York City, a municipal institution, is a series of multi-storied pavilions. Data are based in part on a summary by A. G. Stephenson, Australian architect, which appeared in *The Modern Hospital*.

Top: U. S. ARMY LA GARDE HOSPITAL, NEW ORLEANS, LA. FAVROT AND REED, ARCHITECTS AND ENGINEERS. Lower photos: BILLINGS GENERAL HOSPITAL, FORT BENJAMIN HARRISON, INDIANA. McGUIRE AND SHOOK, ARCHITECTS; BEVINGTON AND WILLIAMS, ENGINEERS

PLANNED IN PAVILION UNITS HERE AND ABROAD



Photos courtesy Trone Co.

ADMINISTRATION UNIT

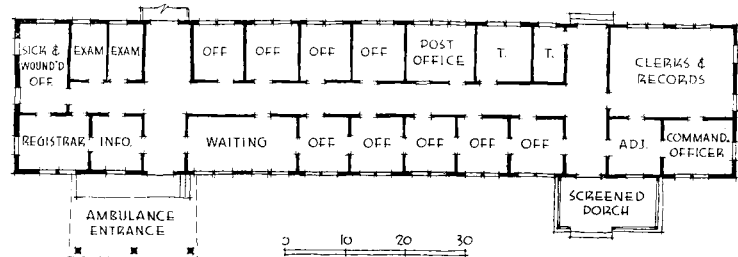

THE UNITED STATES has adopted the principles of pavilion planning for many of its military hospitals. The tremendous expansion of army camps has necessitated numerous hospital buildings. Such institutions have to be built quickly; most are expected to be temporary; they have to be inexpensive; each hospital has to provide for potentially huge numbers of patients. Pavilion plans permit these fundamental requirements to be met, and have at least two further advantages. Once the central administrative offices and services are established, expansion is a comparatively simple matter; and if construction cannot proceed quickly enough to meet the demand for bed space, pavilions can be occupied as they are finished—occupancy does not have to wait upon completion of the entire project.

La Garde Hospital, army institution in New Orleans, is an excellent example. It was built in 74 days by 4,747 men; the power plant was in operation after 32 days. Construction is such that, when the project is abandoned, the minimum capital outlay will be lost; probably, figured as an amortizing project, the hospital will have earned at least 100 per cent of its cost. Its gas and electricity requirements have been compared to those of a city of 30,000 people.

La Garde's pavilions cover 50 acres of a 105-acre lakefront site, and are connected by walks, most of them covered. Units, typical of this kind of hospital, include administration offices, store houses, mess halls, power plant, incinerator, laundry, gas station and garage, fire house, cold storage plant, kitchen, cafeteria, and recreation building, in addition to dental clinics, an infirmary, and 28 ward buildings, detention wards, guard houses and a morgue. Close-ups of Billings Hospital's ward units indicate the usual type of construction.

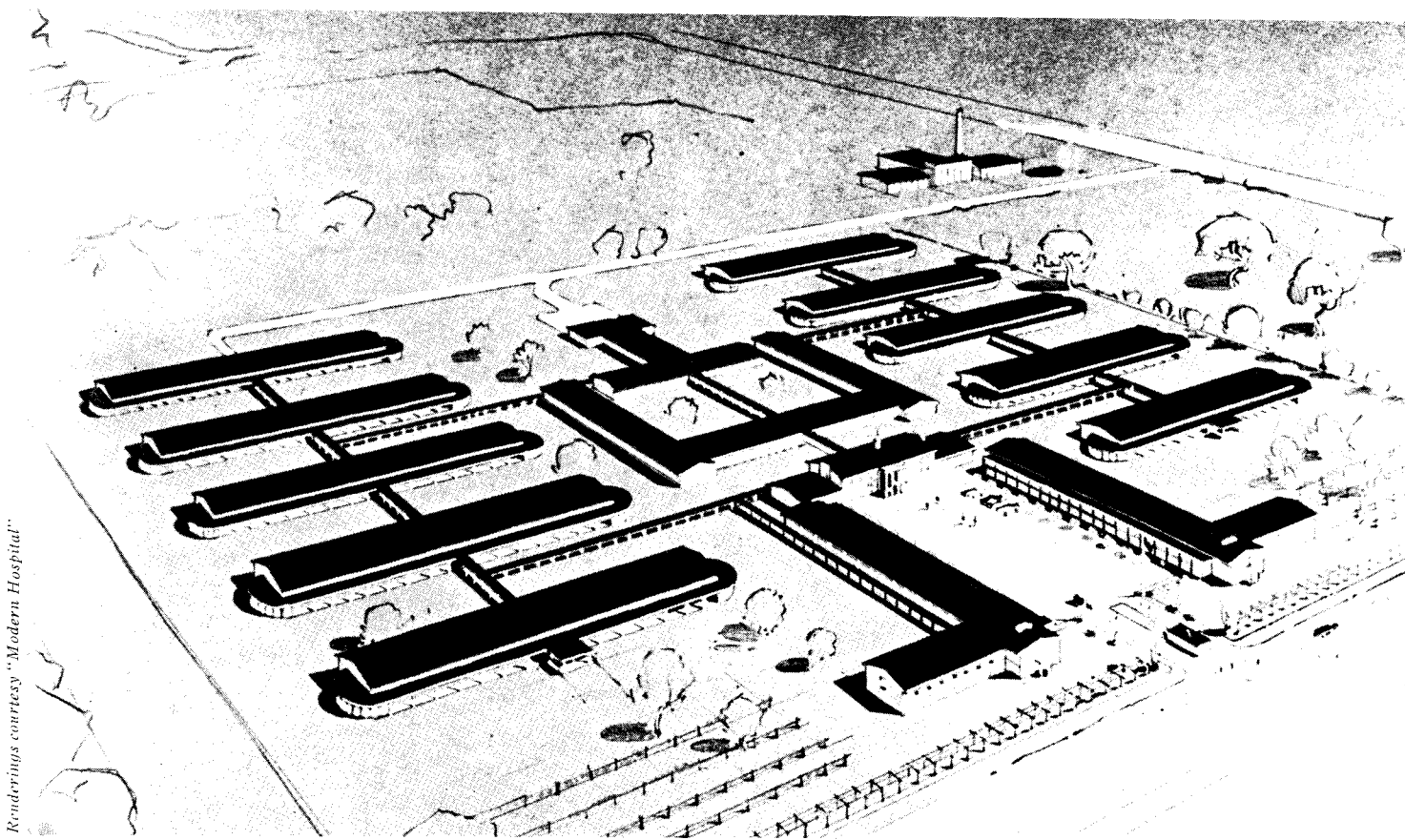

Renderings courtesy "Modern Hospital"

ADELAIDE, S. A.

GENERAL MILITARY HOSPITALS, ADELAIDE, BRISBANE AND YARALLA, AUSTRALIA. STEPHENSON AND TURNER, ARCHITECTS.—Institutions in Adelaide and Brisbane are temporary or semi-permanent; Yaralla Hospital is permanent. The latter, illustrated in plan, is a multi-story "T," with a ward per floor per wing. Typical ward pavilion for Adelaide and Brisbane is on facing page.

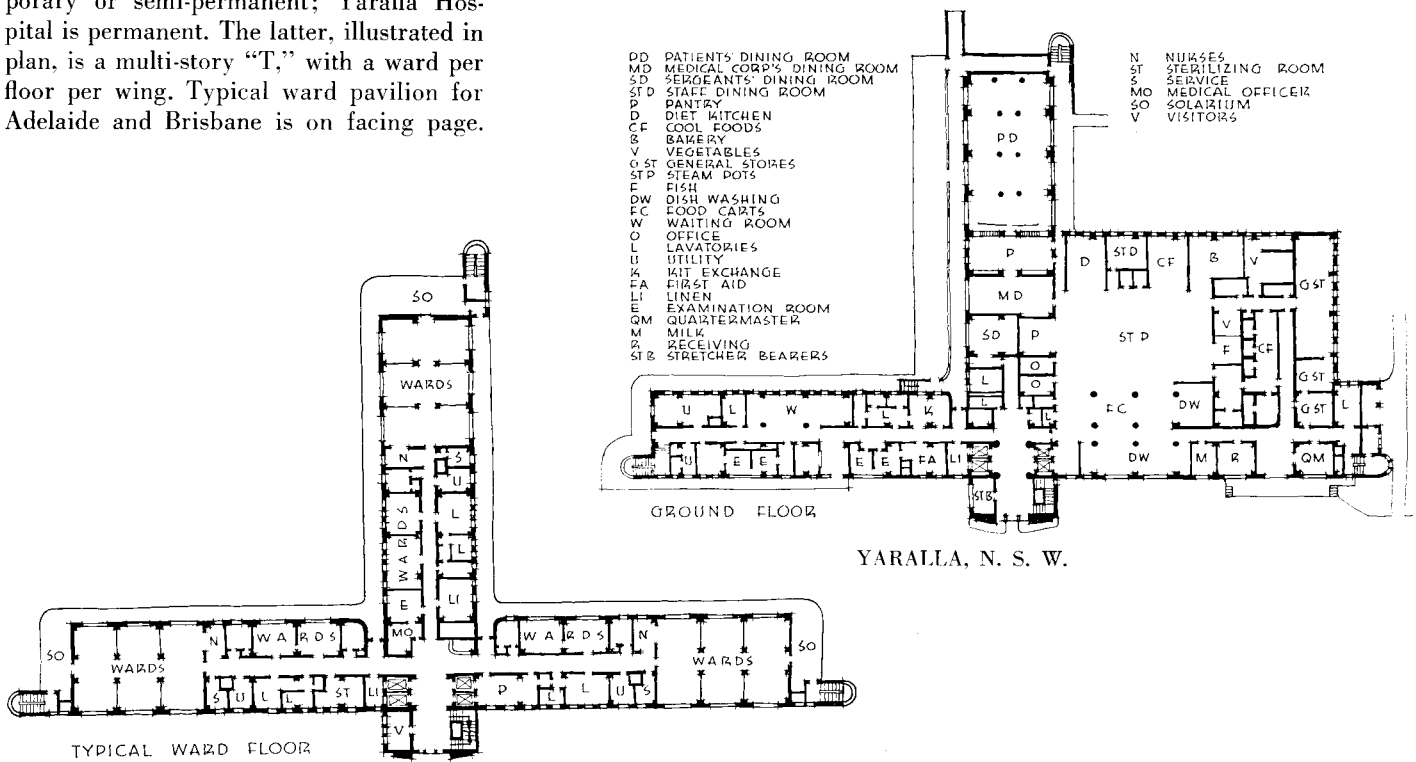

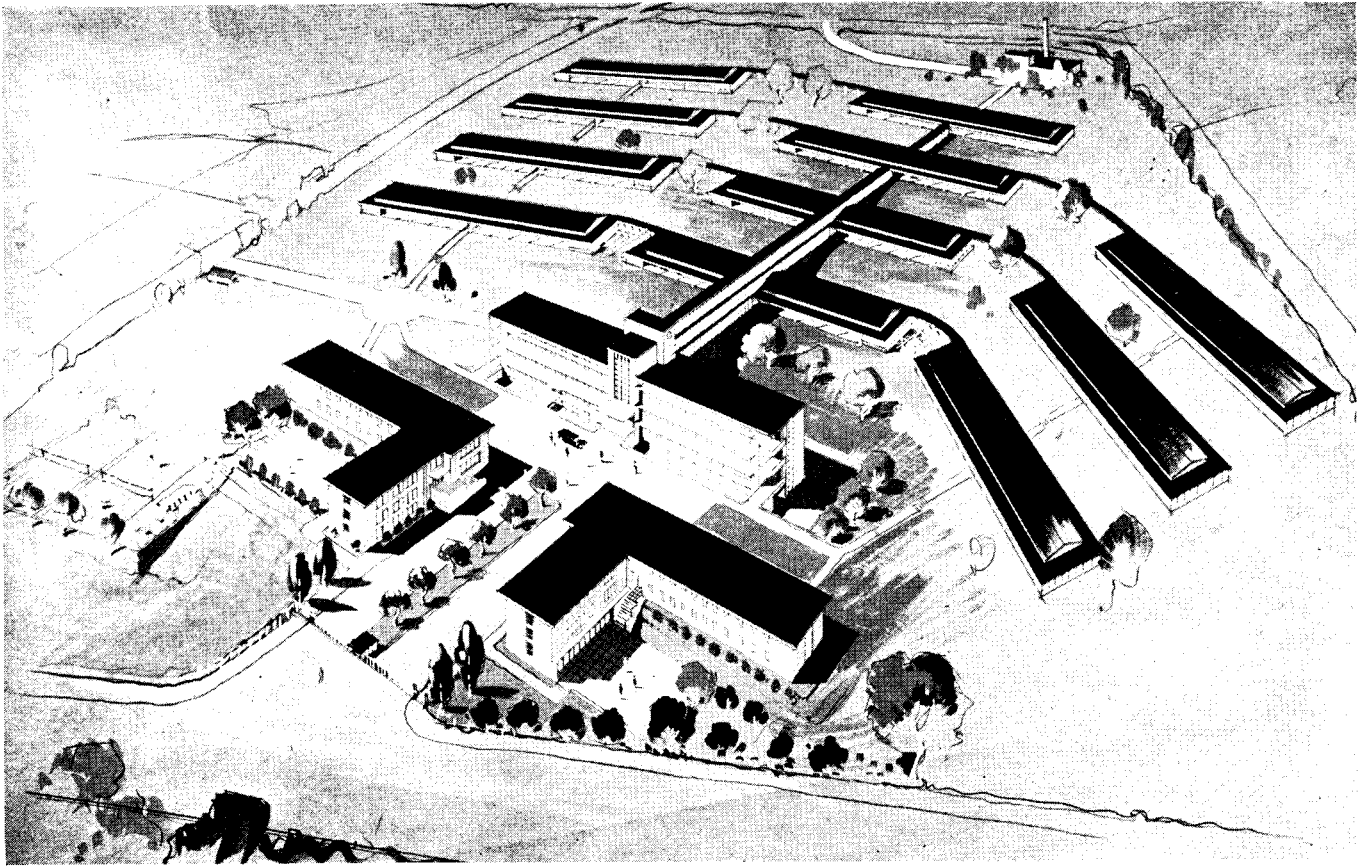

BRISBANE, Q.

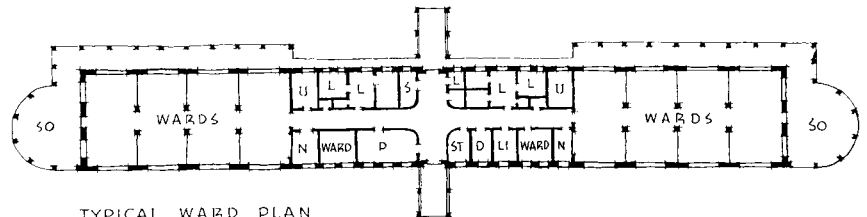

TYPICAL WARD PLAN
ADELAIDE AND BRISBANE

IN AUSTRALIA military hospitals are of four general types: camp hospitals, temporary pavilion types, permanent pavilion types, permanent multi-storied types. Military authorities prefer pavilion plans.

Sites selected for Australian hospitals had to be level; or at least of a 1 to 18 or 20 maximum grade—most desirable for economical pavilion construction. When accessibility or other administrative reasons force selection of a hilly site, multi-storied administrative blocks at low points of sites serve ward pavilions laid out to contours. Adelaide hospital has a level site; Brisbane's plot slopes.

Each pavilion hospital had to be planned for expansion up to four times initial development. Brisbane has wards for 200 wounded; services are departmentalized, have capacity for 400 beds, are so laid out that each department's capacity can be increased to an ultimate 800 beds.

Facilities include examination, treatment and physical therapy clinics, and provisions for special types of wound treatments. In permanent hospitals, 100 sq. ft. per bed is minimum; in temporary units, 80 sq. ft. per bed. Permanent ward units each contain one 24-bed ward, two 3-bed wards, two 1-bed wards (total, 32). Pavilions each house 68 beds: two 32-bed wards, two 2-bed. Costs for one permanent hospital averaged \$3,400 (U. S. currency) per bed; for a pavilion hospital, \$3,150 per bed for initial capacity, with beds in additional pavilion units costing \$530 each.

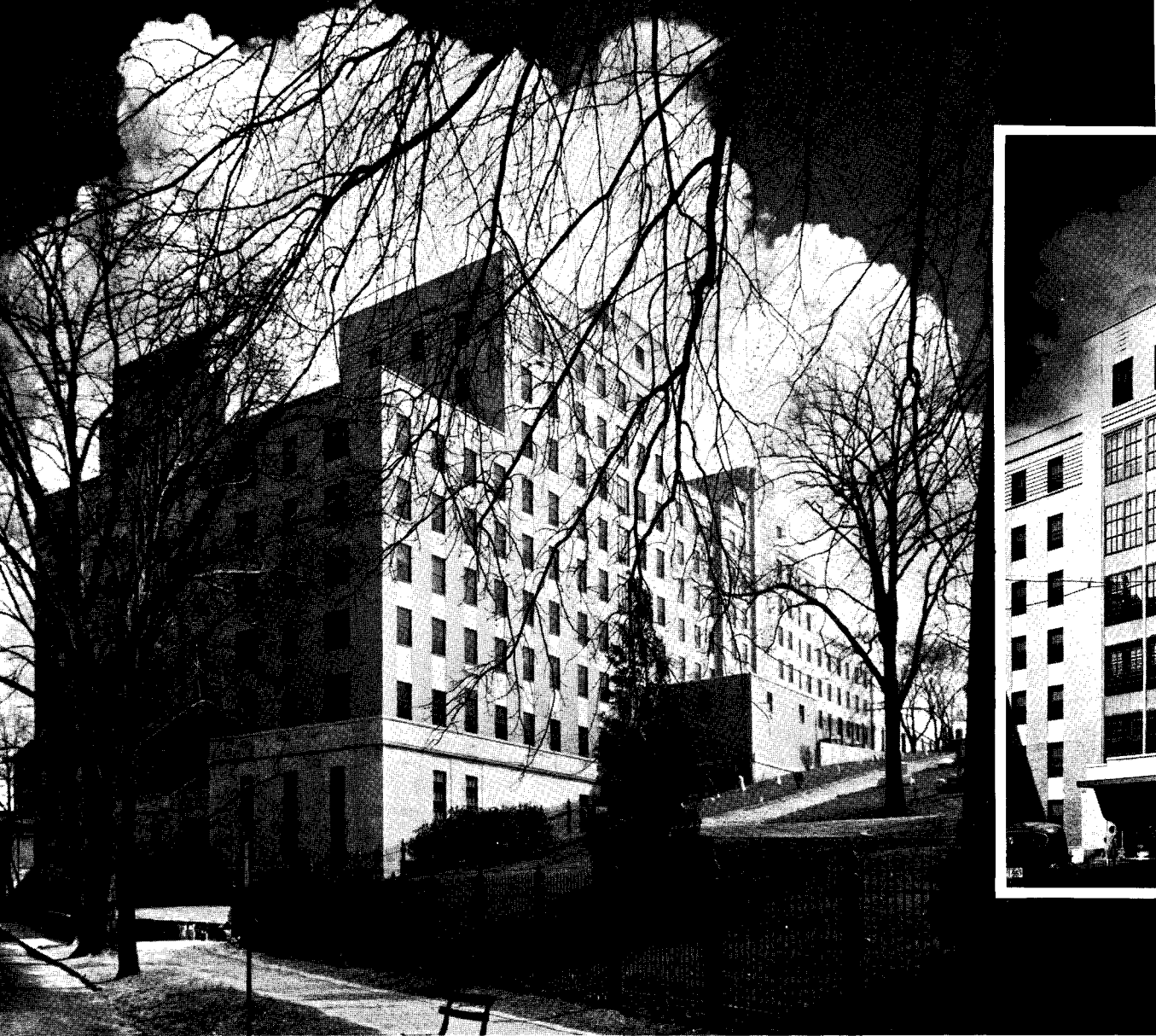

NEW GENERAL HOSPITAL BUILT AROUND OLD

DELAWARE HOSPITAL, WILMINGTON, DEL. MASSENA AND DUPONT, ARCHITECTS. As the plot plan shows, new units of this privately financed general hospital enclose the old buildings, which were maintained in operation until new quarters could be occupied. Unit 1—administrative, surgical and private rooms—and Unit 2—clinics, wards, nursery, maternity—are now completed. Unit 3—nurses' home—is under construction; old nursing school between Units 2 and 3 is being incorporated in new work. Because the hospital is the only one in the heart of Wilmington, it gets 80 per cent of all accident, emergency and clinic patients. Present designed capacity is 344 beds, capable of expansion to 700 beds. Units 1, 2 and 3 are estimated to cost \$3,392,285; cost per cu. ft., 85c.; cost per bed (344 beds) \$9,861.29.

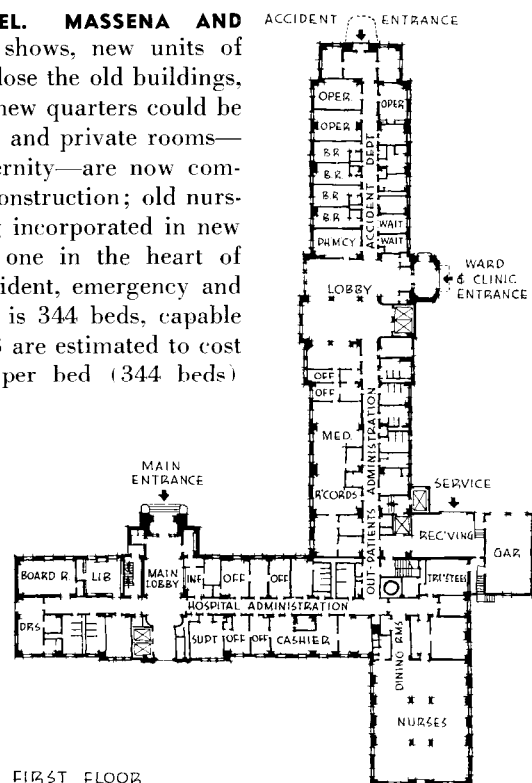
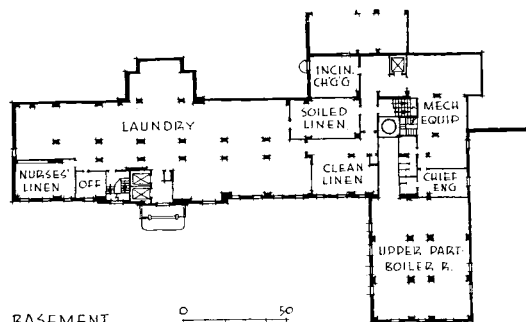
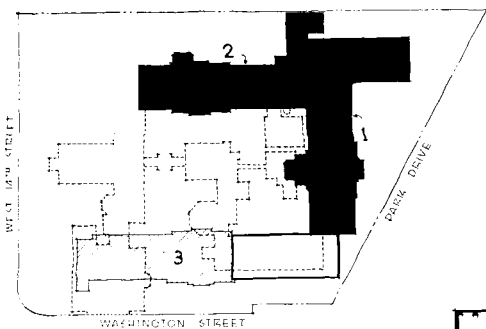

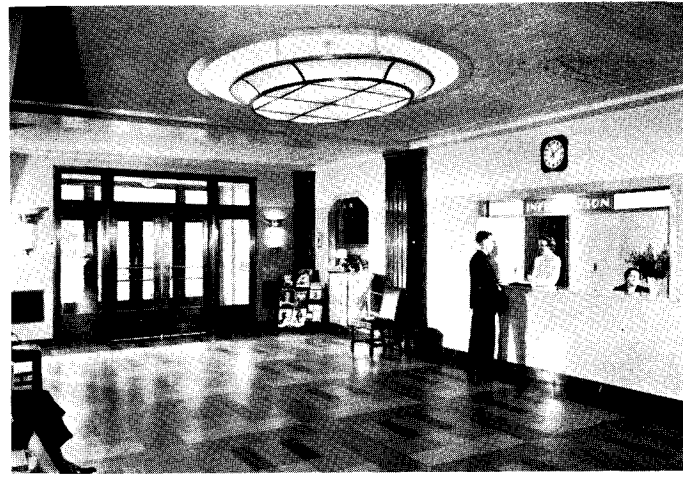

Photos by H. M. Rittase

Photos, left to right: exterior; main entrance; clinic entrance; lobby, Unit 1; clinic lobby, Unit 2. Structure has reinforced concrete skeleton, brick walls shaded progressively lighter from base to coping, limestone trim. Color is extensively used in operating rooms, public and private bed spaces. All possible means of noise control are employed; sources are eliminated or acoustically treated; installation of sound-deadening material is called largest in any privately financed hospital. Signal system operates lights instead of loud speakers or bells

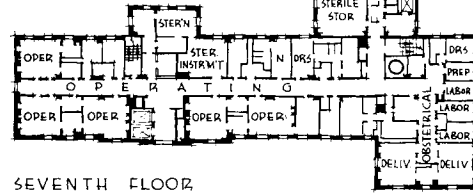
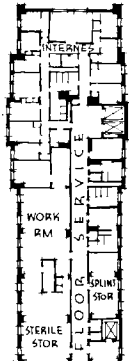

SEVENTH FLOOR

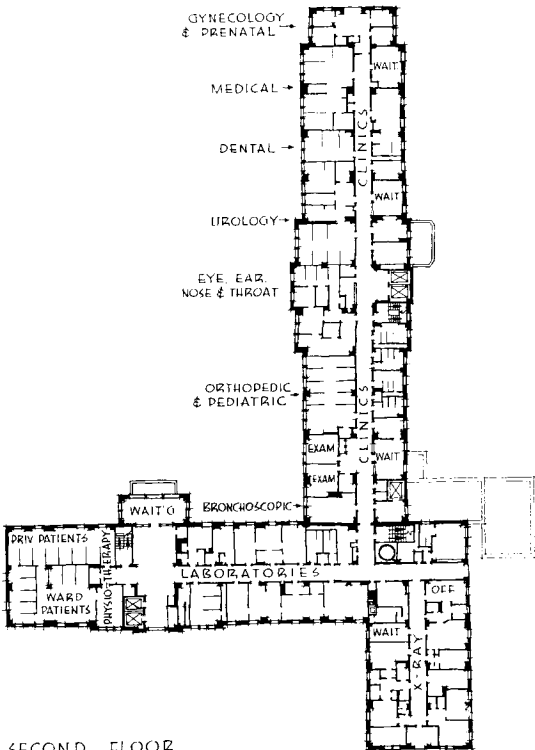

SECOND FLOOR

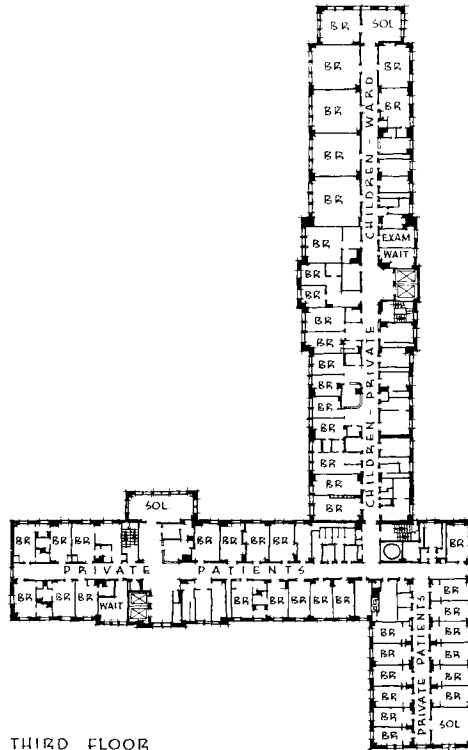

THIRD FLOOR

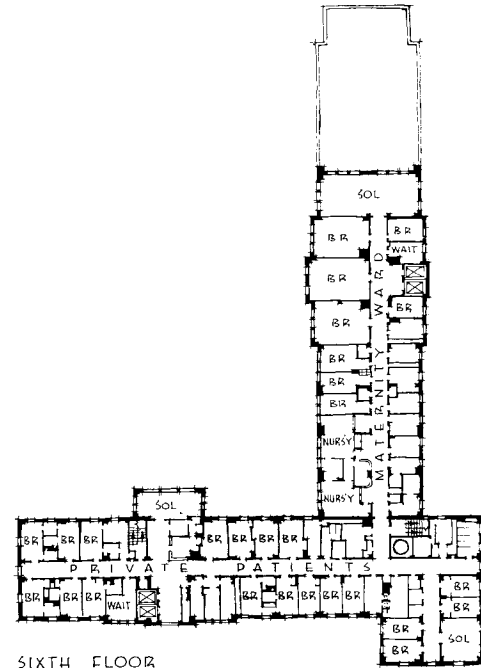

SIXTH FLOOR

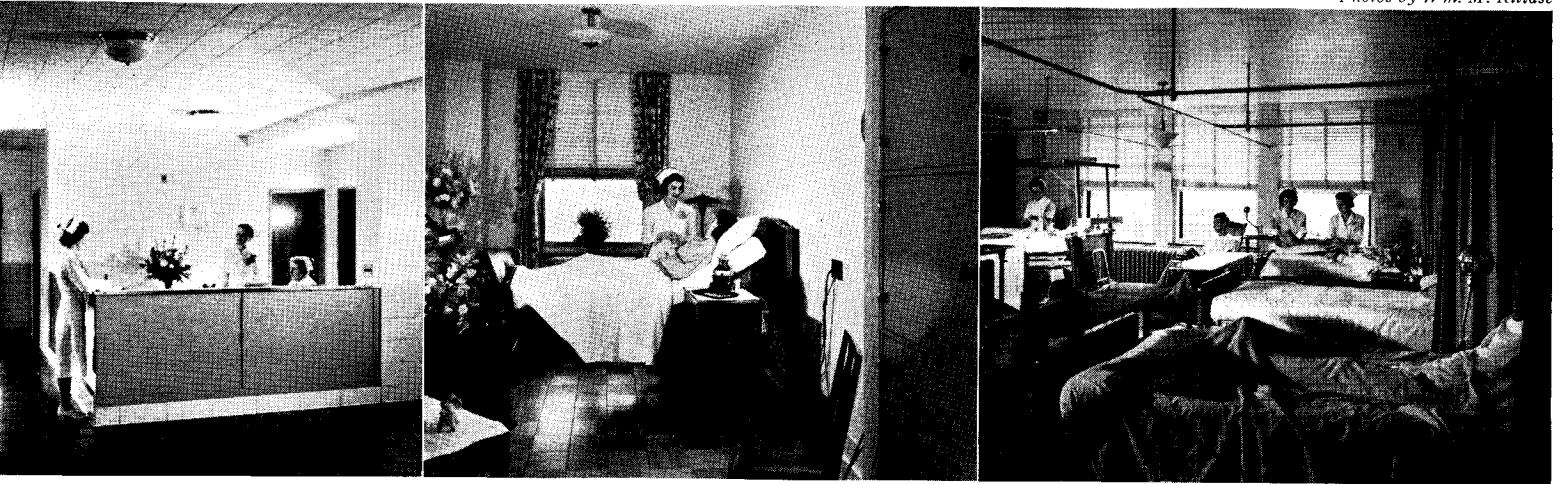

Left, NURSES' STATION; center, PRIVATE ROOM (both in Unit 1); right, ADULT WARD, Unit 2. Each floor has medicine and floor service rooms to centralize supplies for local needs, instead of keeping medicines in nurses' stations. Central supply service room on the 7th floor handles all needs for all floors; delivers orders via electric lift in 41 seconds

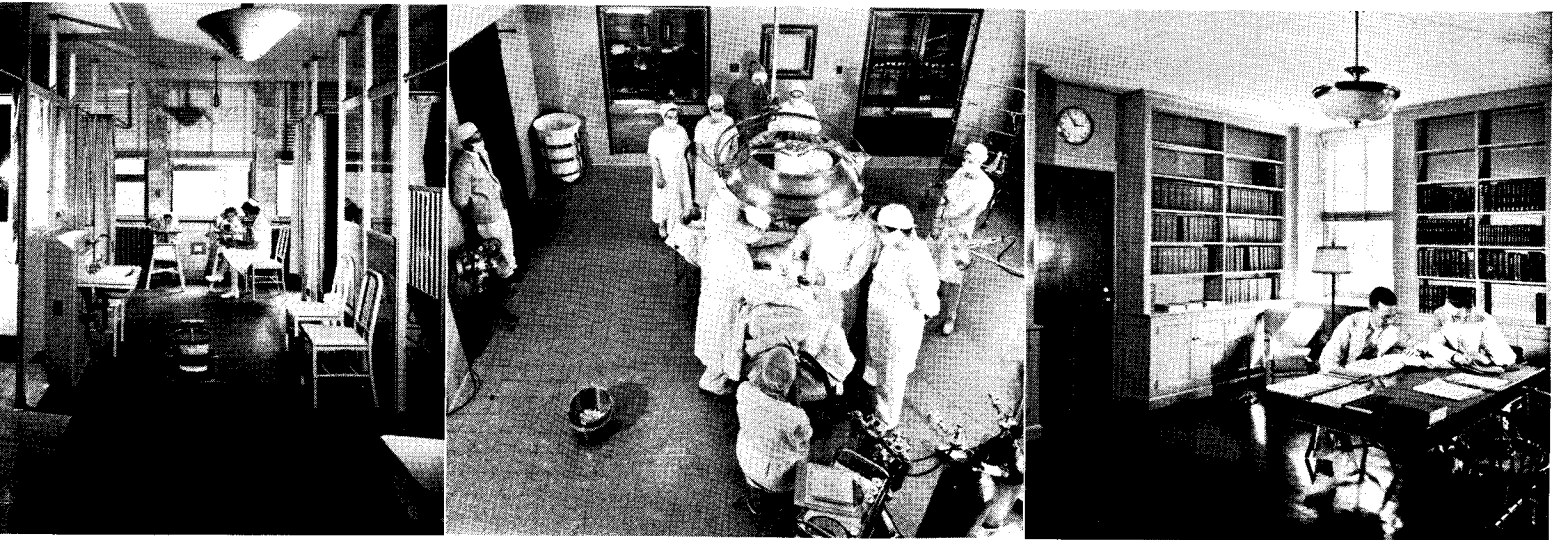

Left, CHILDREN'S WARD, Unit 2; center, OPERATING ROOM; right, MEDICAL LIBRARY (both in Unit 1). Operating rooms are all-year air-conditioned with special attention to features which minimize dangers of static explosions, and of infections. Ultra-violet fixtures are bactericidal. Light blue tile walls ease eyestrain



Extreme left, X-RAY CONTROLS for complete diagnostic and therapeutic equipment. Left center, PHYSIOTHERAPY ROOM with treatment cubicles. Right center, COMPLETE SUITE OF LABORATORIES, near operating room. Right, FLOOR SERVING PANTRY: food trays traverse "assembly line" 10 seconds apart, reach patient via subveyor in 4 minutes

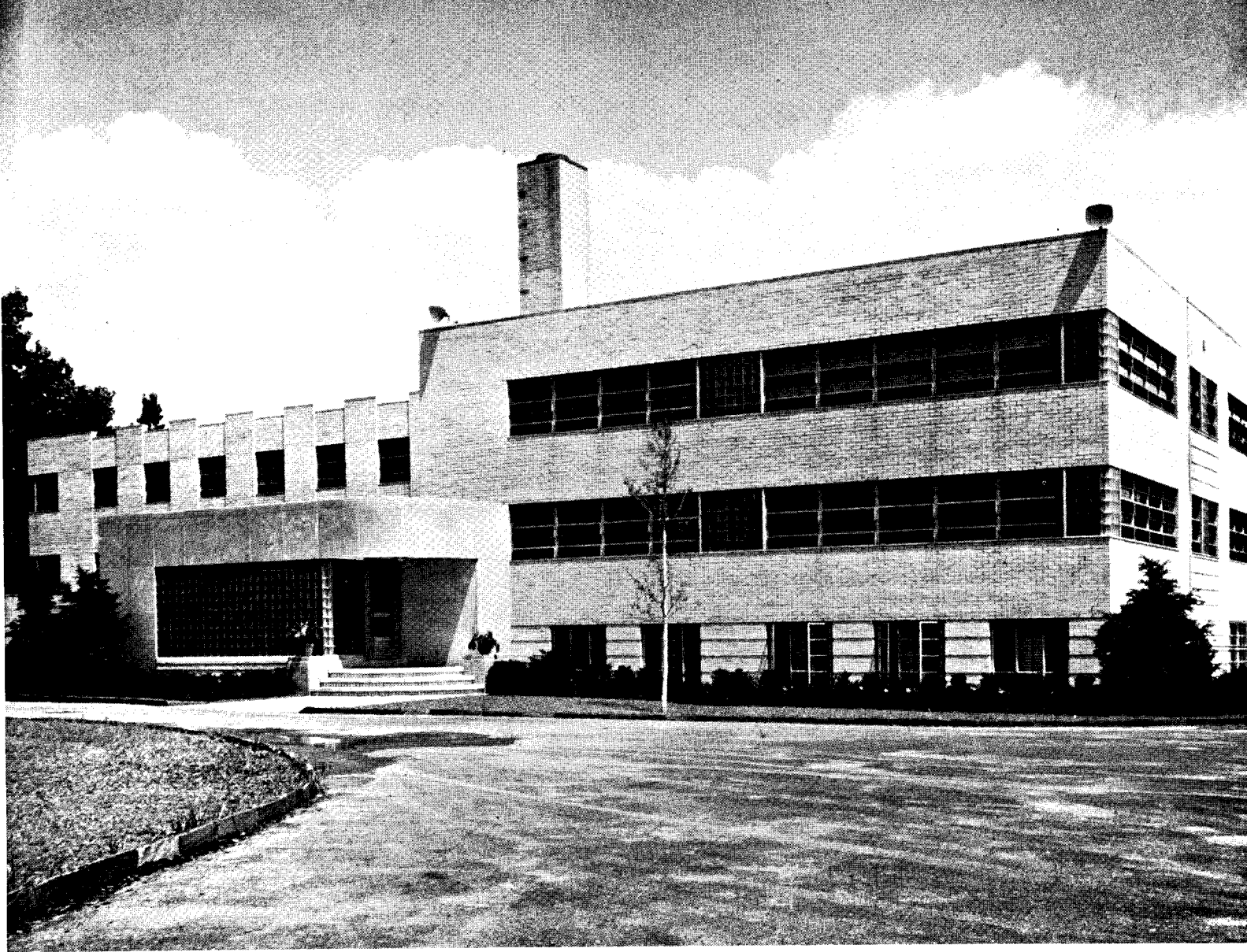

HOSPITAL TO CURE MENTALLY ILL

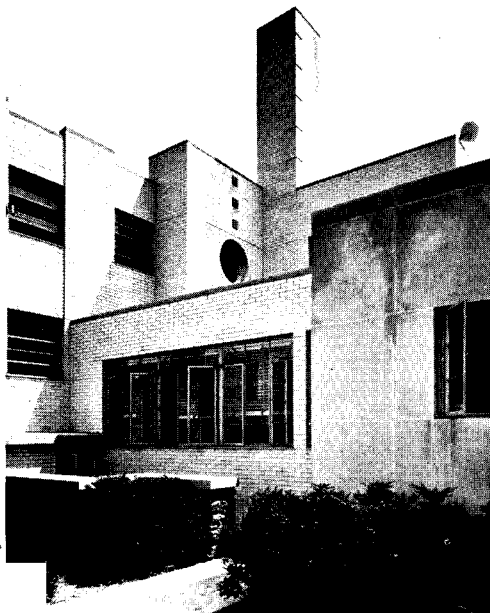
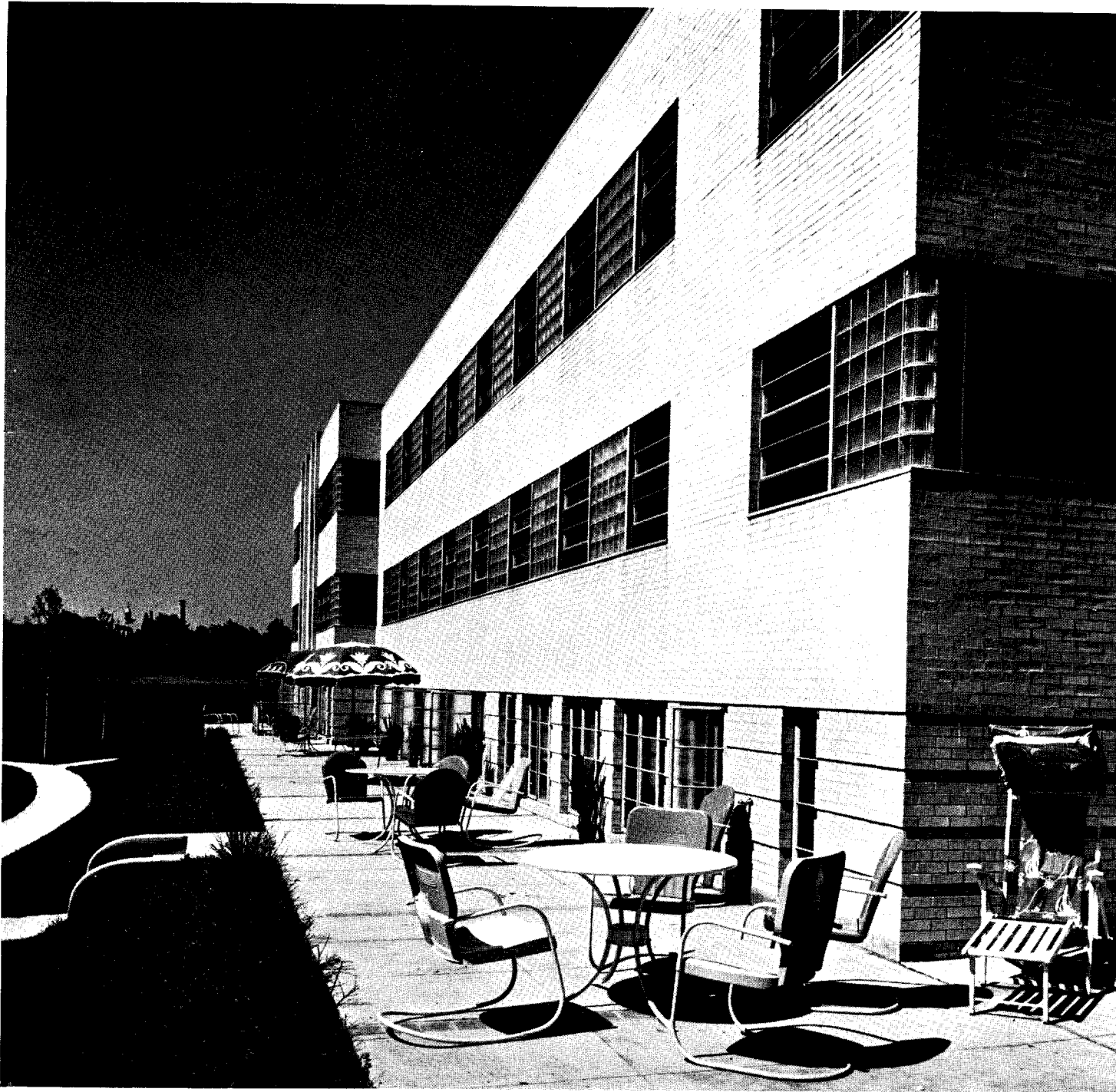

Photo by C. V. D. Hubbard

PHILADELPHIA PSYCHIATRIC HOSPITAL, PHILADELPHIA, PA. THALHEIMER AND WEITZ, ARCHITECTS; HORACE FLEISHER, LANDSCAPE ARCHITECTS. This building is designed to further experiments started some years ago for treating men and women for whom there is hope of recovery from mental strain. This attitude is apparent from a study of the plans and photographs. Rooms are cheerful in comparison with accommodations in most similar institutions. Even such small items as the windows, though they are of "detention" type, are so handled that the quality of restraint is unobtrusive.

The entire development comprises a Nurses' and Doctors' Home and the hospital proper, which latter is illustrated here. The large irregular plot is in an excellent residential section, where streets are wide and relatively free of traffic. Existing landscaping is retained as far as possible. An old mansion has been remodeled into a Nurses' and Doctors' Home at a cost of approximately \$14,000.



TERRACE for patients and visitors is included in landscaping

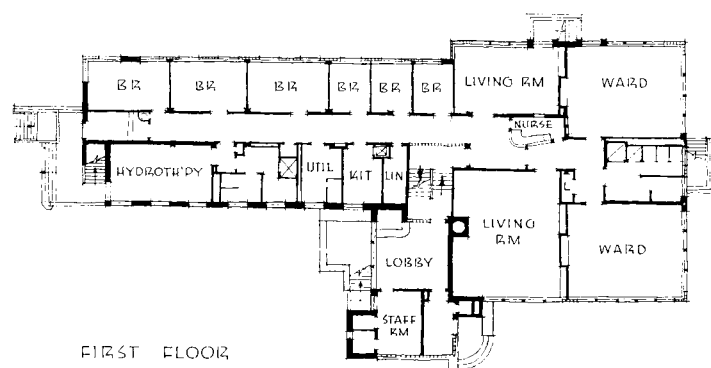
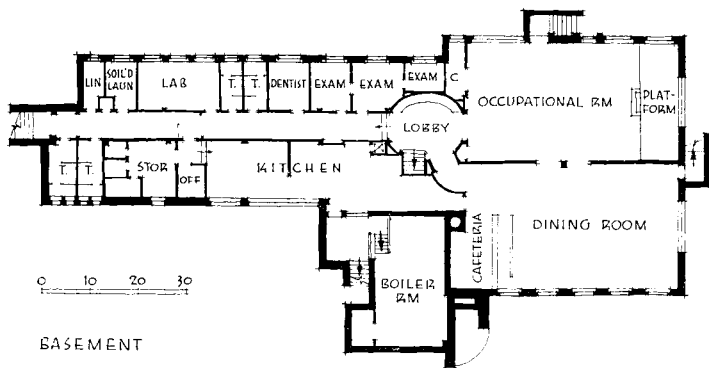

PHILADELPHIA PSYCHIATRIC HOSPITAL,
THALHEIMER AND WEITZ, Architects;
HORACE FLEISHER, Landscape Architect
 (continued)



RECEPTION LOBBY

HOSPITAL BUILDING PROPER is oriented to take maximum advantage of sunlight and prevailing breezes, and is thoroughly modern in equipment and construction. Construction is concrete and steel. Generous quantities of glass and glass block are used to lighten the interior. Accommodations total 60 beds, arranged on first and second floors in the following units: 3-bed semi-private rooms; private rooms; and 8-bed wards. Instead of the institutional solarium, each group of patients has the use of a "living room," furnished comfortably and cheerfully. In addition, each floor has its kitchen, utility room, hydrotherapy room, linen closets, toilets, etc., and is supervised from a central nurses' station. Facilities which serve the hospital as a whole are concentrated in the basement.

This project was envisioned from the start as one of the leading institutions of its kind. The building is planned for expansion. Cost of hospital proper was approximately \$100,000, excluding land and equipment. Mechanical equipment cost \$30,000.



TYPICAL "LIVING ROOM"

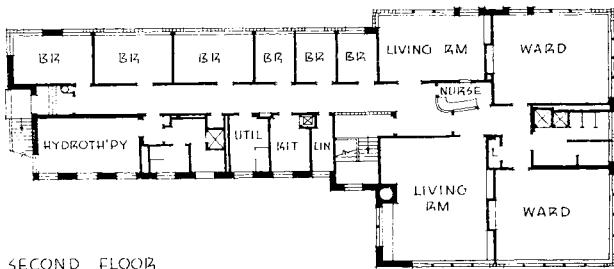

SECOND FLOOR



PRIVATE ROOM

Photos by C. F. D. Hubbard

ARCHITECT MAKES SURVEY, PLANS PROGRAM



Photos courtesy "Portland Cement Assn."

CITY HOSPITAL, OSWEGO, KANSAS. THOMAS LARRICK, AIA, ARCHITECT. The architect was asked to assist in preparing the program for the building, which involved passing some legislation to make it lawful for this second-class city to build a hospital. A survey to determine the number of beds and hospital facilities needed, and presentation of the entire program to the community for their approval, were additional duties of the architect.

Due to the location on main thoroughfare, it was desirable that the building be placed well back on the lot. The service drive passes behind the building; at all points it is kept at some distance so traffic will not annoy the patients. The fact that the building was to be built by the WPA determined that it should be of monolithic concrete, divided into three main sections, separated by expansion joints.

Administrative and service facilities are in the central block, with staff quarters above. The one-story wing to the south contains well-oriented patients' rooms; the west wing houses surgical and clinical rooms. North light is provided for operating and delivery rooms, which are on the ground floor. Both wings are designed for future second stories. Total cost was \$64,250; without equipment, the cu. ft. cost was approximately 41c.

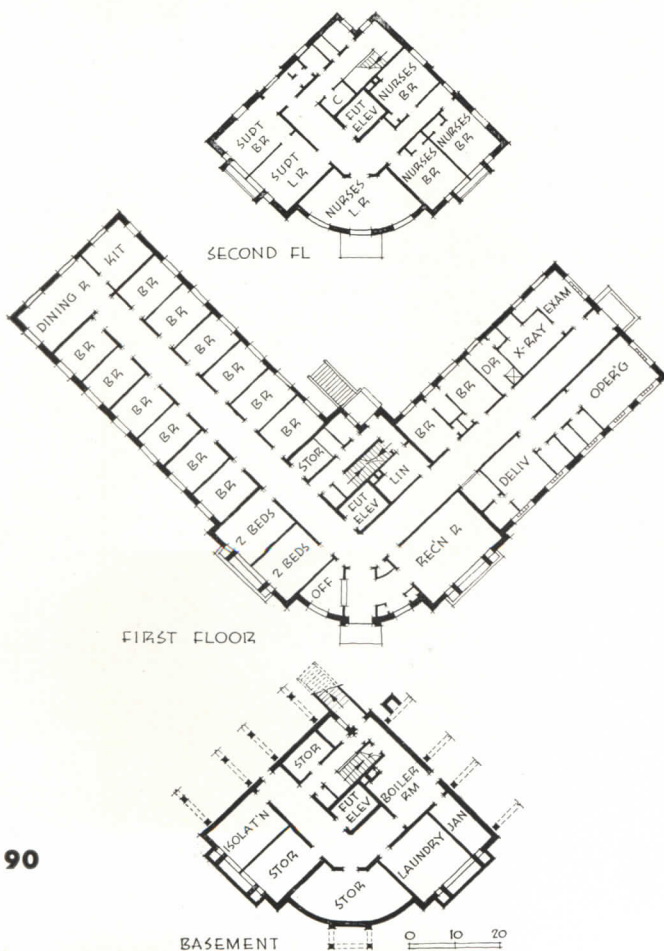

120-ROOM HOSPITAL SERVES SOUTHWEST ALASKA

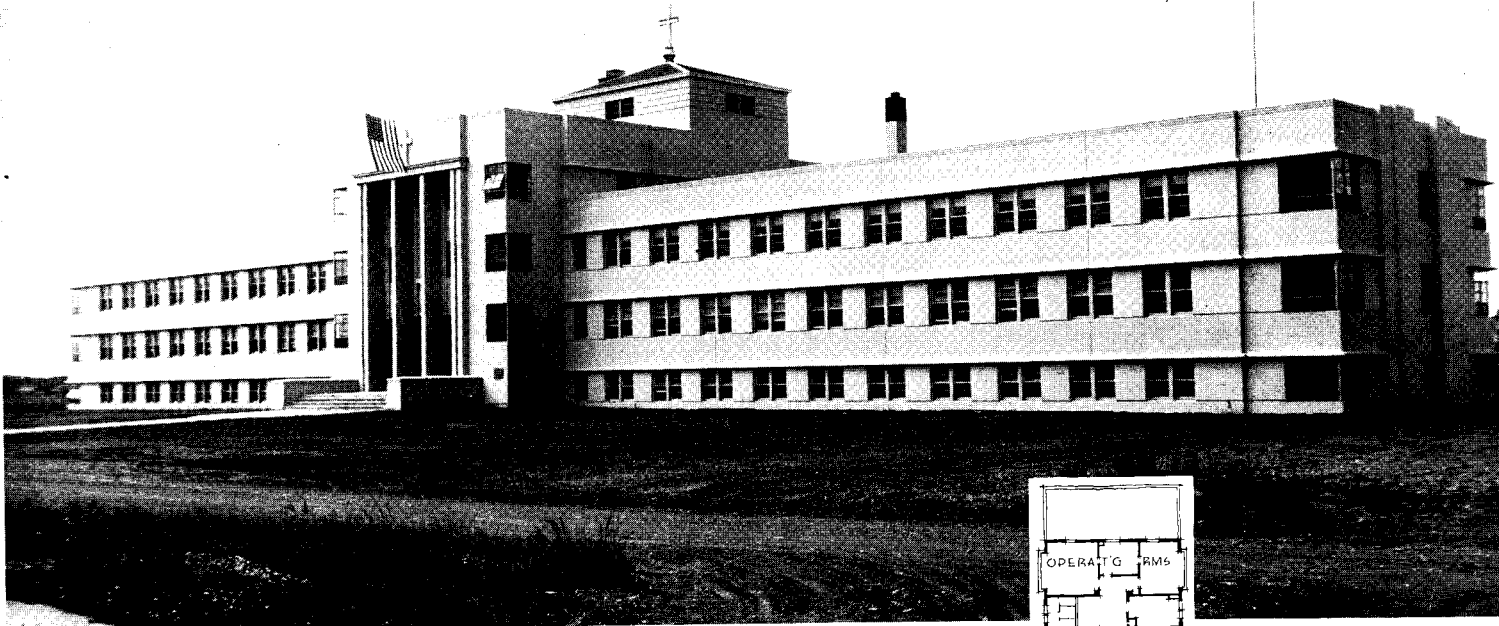

PROVIDENCE HOSPITAL, ANCHORAGE, ALASKA. JOHN W. MALONEY, AIA, ARCHITECT. Near Anchorage, which is almost 2,000 miles from continental United States, are Matanuska Settlement, several coal mines, and a new U. S. Army air base. The region is well established and has definite future prospects. The Sisters of Charity determined upon high standards for both equipment and construction of Providence Hospital. Reinforced concrete construction was chosen for this and several related reasons. Earthquake-resistance was required. Since local materials are almost non-existent—nearly everything is imported by water and rail—local sand and gravel, plus imported cement and steel, were employed. Beams and columns flanking the central corridor support continuous one-way floor slabs; exterior walls and some partitions are concrete.

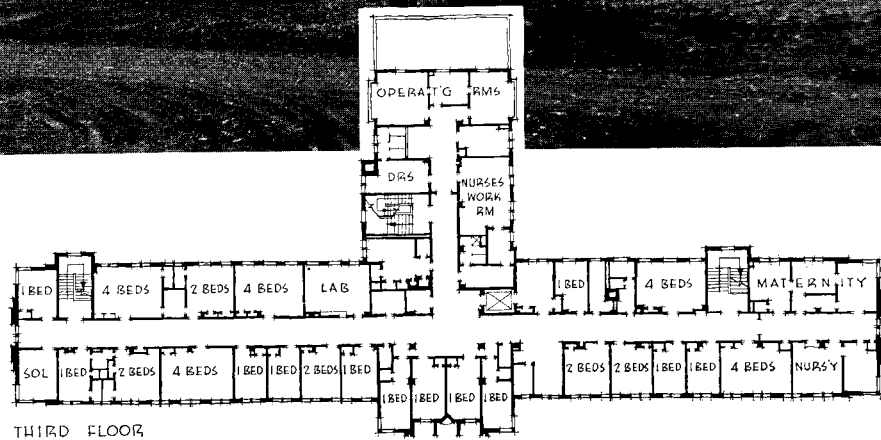

THIRD FLOOR

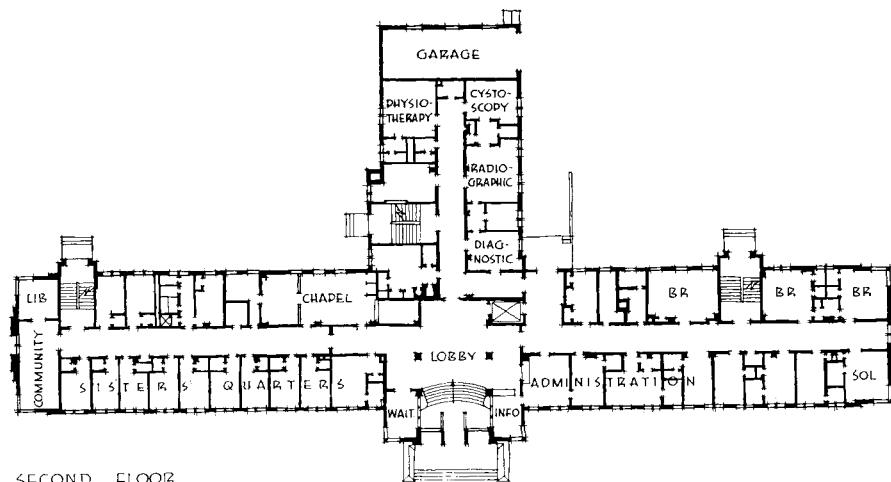

SECOND FLOOR

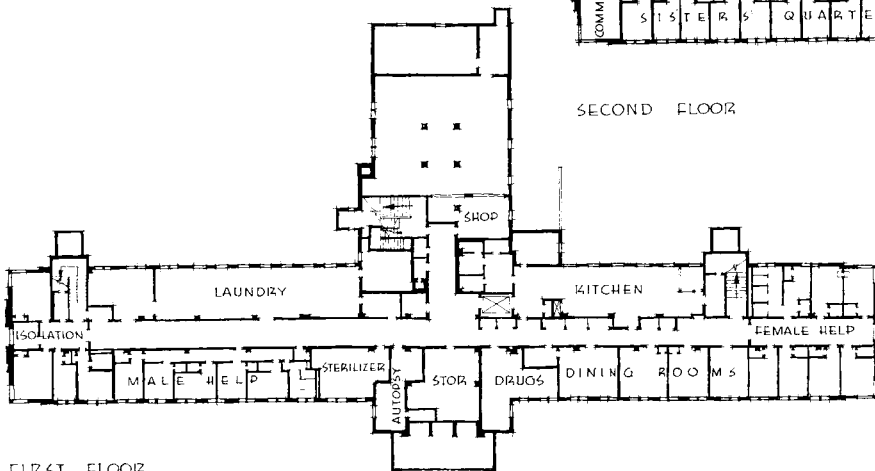

FIRST FLOOR

Photos by Cecil F. Anney

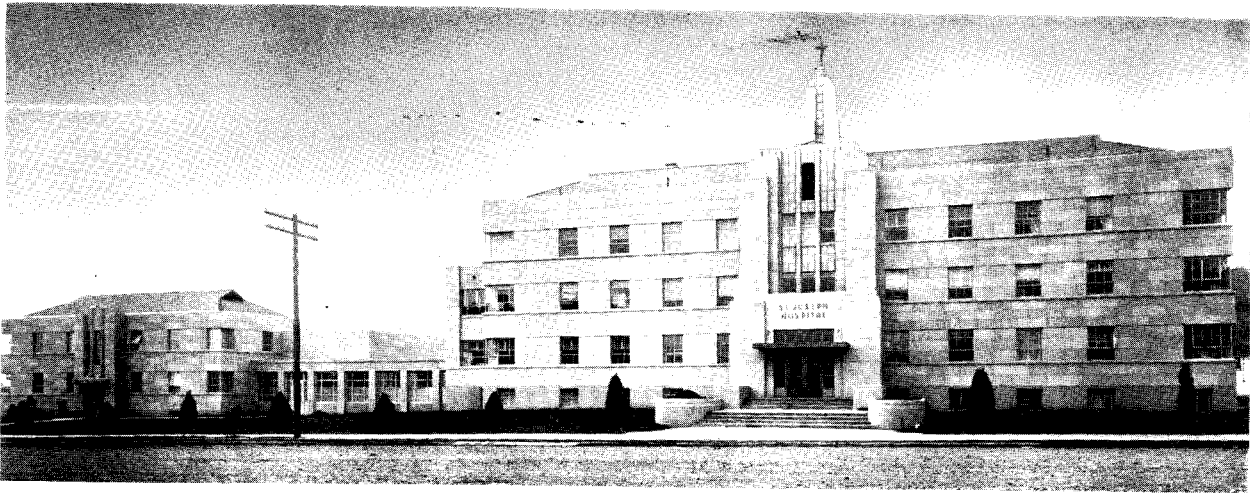

SAND-SURFACED CONCRETE HOSPITAL

ST. JOSEPH HOSPITAL, LA GRANDE, ORE; TOURTELOTTE AND PHILLIPS, ARCHITECTS. The hospital group consists of hospital, convent, chapel, laundry and heater room; and future additions will double patients' accommodations and include a nurses' home. All are of concrete. Exterior surfaces were given an ashlar effect by inserting wood strips in the plywood forms. When forms were removed, a brush coat of portland cement was applied. Into this, while still soft, was blasted fine granite sand to form an integral surfacing. Cost of project was \$180,000 excluding land and equipment.

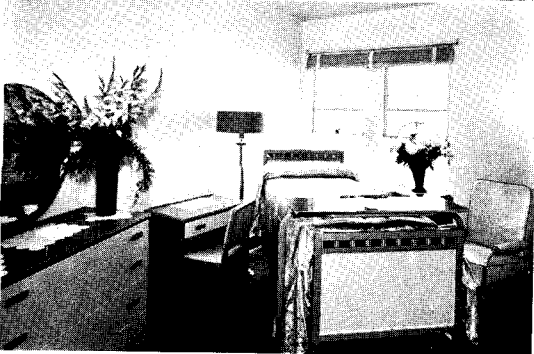

Above, OPERATING ROOM; below, PRIVATE ROOM

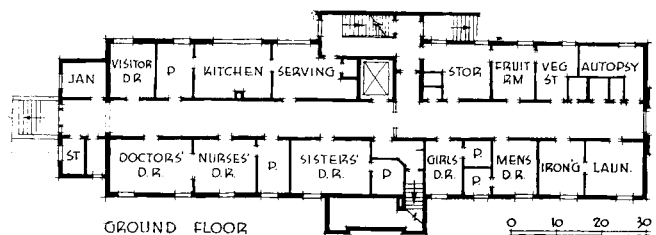
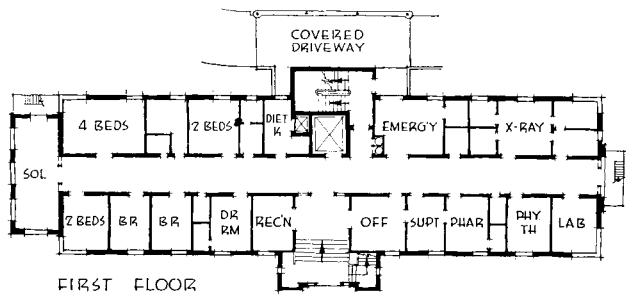
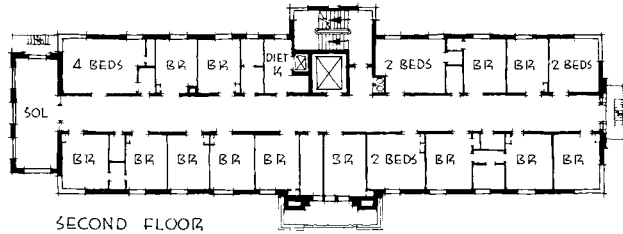
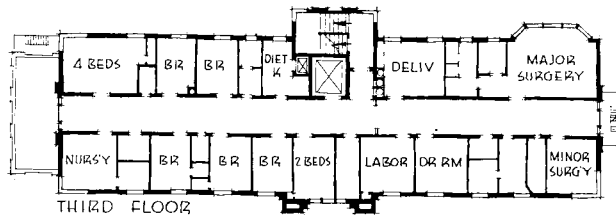

HOSPITALS—PLANNING UNITS

ARCHITECTURAL RECORD
TIME-SAVER
STANDARDS

AUGUST 1941

Information on this sheet was prepared by Ronald Allwork from data furnished by New York City Bureau of Architecture,

Dept. of Public Works, Isadore Rosenfield, Chief Architect—Hospitals, Joseph Blumencratz, Senior Architect—Hospitals.

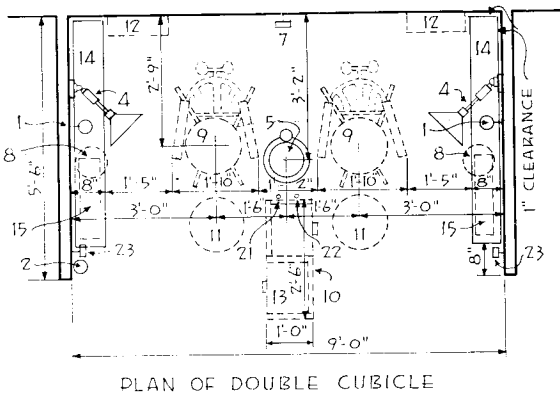
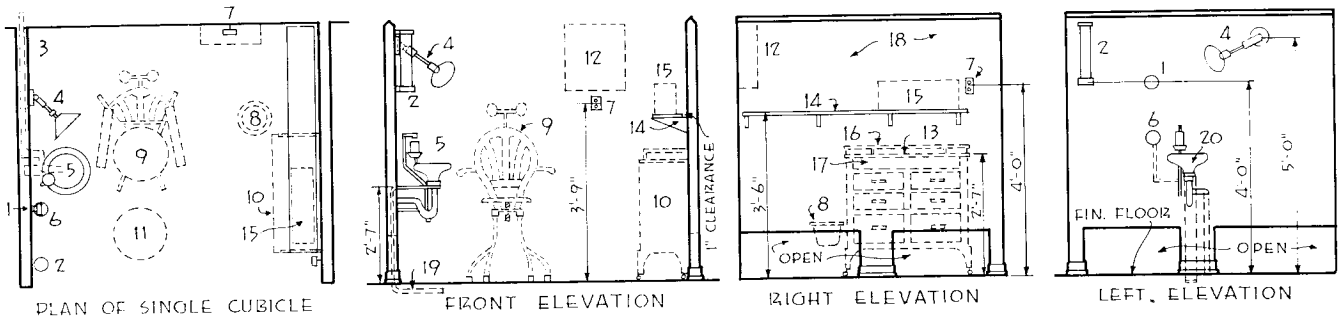

EAR NOSE AND THROAT CUBICLES

- KEY TO ELEMENTS
- 1 POWER RECEPTACLE
 - 2 CUP DISPENSER
 - 3 VENT
 - 4 TELESCOPIC BALL JOINT EXTENSION LAMP
 - 5 CUSPIDOR
 - 6 COMPRESSED AIR COCK AND GAUGE BELOW
 - 7 DUPLEX RECEPTACLE
 - 8 WASTE RECEPTACLE
 - 9 TREATMENT CHAIR
 - 10 INSTRUMENT TABLE
 - 11 DOCTOR'S STOOL
 - 12 SPACE FOR VIEWING CABINET
 - 13 TRANSPARENT GLASS TOP
 - 14 MONEL METAL SHELF AND BRACKETS
 - 15 SPACE FOR PORTABLE ELECTRIC STERILIZER
 - 16 METAL TRAILING
 - 17 OPEN SHELF
 - 18 FLUKE METAL PARTITION
 - 19 CONCEALED FLOOR BRACKET
 - 20 WATER OPERATED SUCTION
 - 21 VACUUM
 - 22 COMPRESSED AIR
 - 23 OUTLET FOR STERILIZER

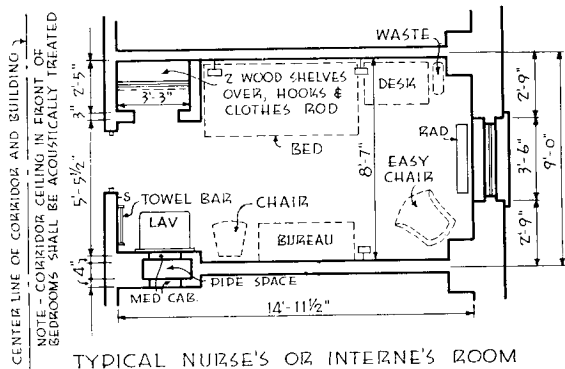
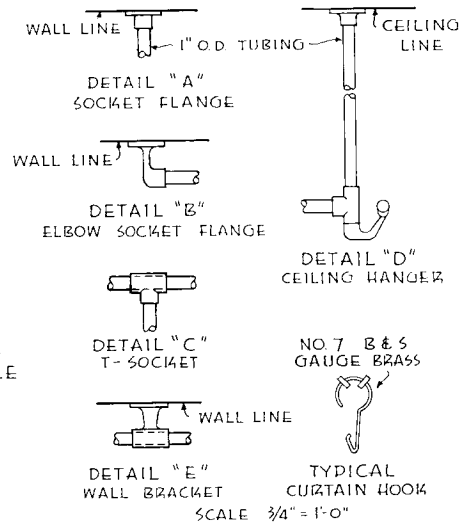
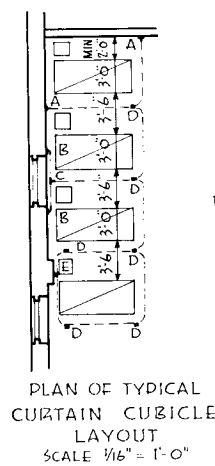
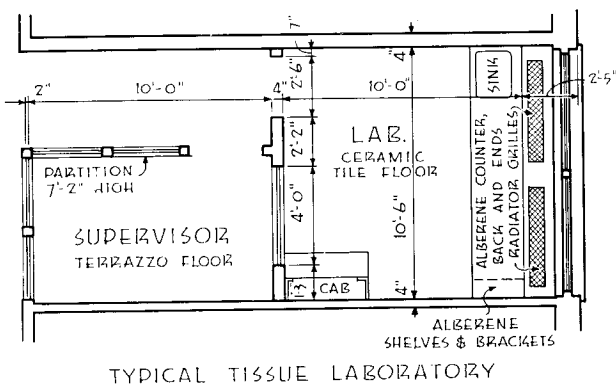

NOTE - CURTAIN TRACKS, FITTINGS, CURTAIN HOOKS, ETC., SHALL BE OF BRASS OR BIZONZE - CHROMIUM PLATED - SATIN FINISH

TYPICAL HOSPITAL PLANNING DETAILS

SCALE 1/8" = 1'-0"

UNLESS OTHERWISE NOTED

HOSPITALS—PLANNING UNITS

AUGUST 1941

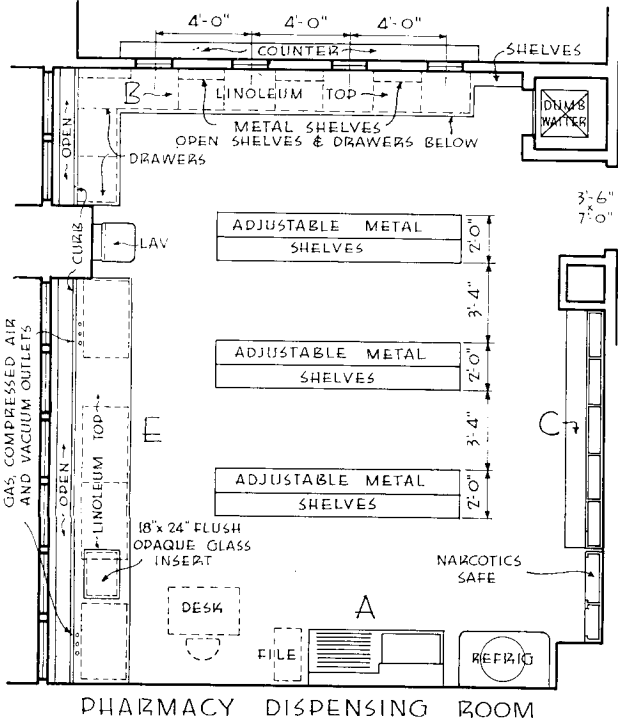

PHARMACY DISPENSING ROOM

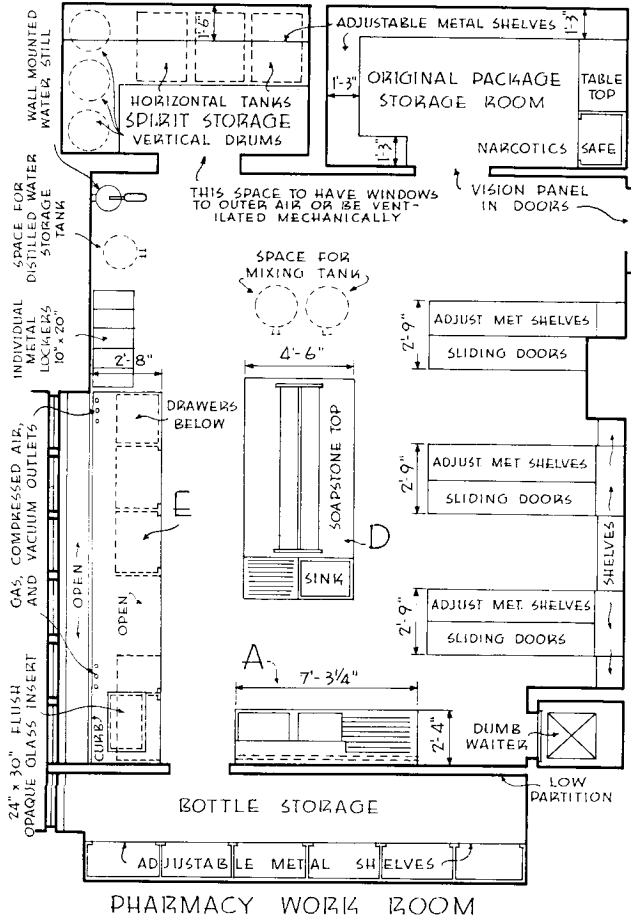

PHARMACY WORK ROOM

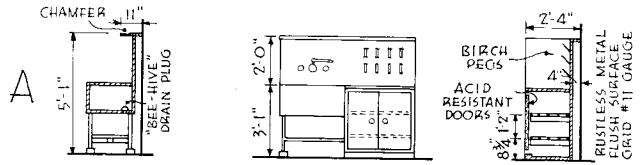

PHARMACY SINK

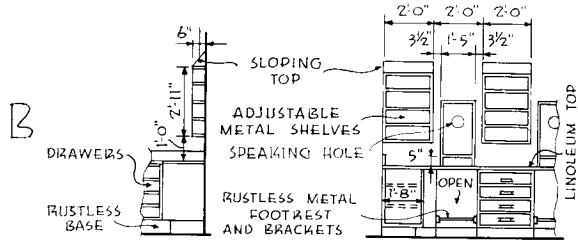

DISPENSING COUNTER

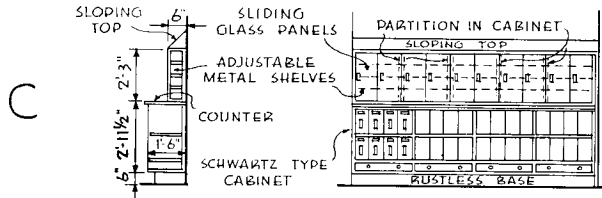

PRESCRIPTION COUNTER

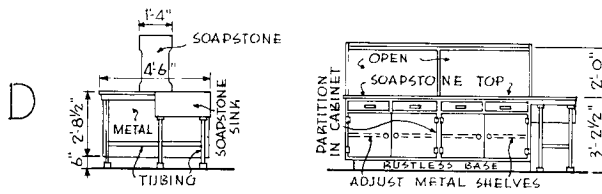

LABORATORY TABLE

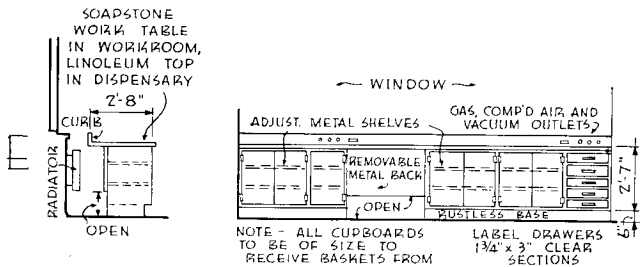

WORK TABLE

TYPICAL PHARMACY PLANNING DETAILS

SCALE 1/8" = 1'-0"

NOTES - 1 SIZE OF WORK ROOM AND STORAGE ROOMS AND SIZE AND NUMBER OF EQUIPMENT UNITS ARE SUBJECT TO VARIATION DEPENDING UPON REQUIREMENTS OF EACH SPECIFIC INSTITUTION.

2 WORK AND DISPENSING ROOMS MUST NOT NECESSARILY BE PLACED ONE OVER THE OTHER. HOWEVER, EASY COMMUNICATION BETWEEN THE TWO IS ESSENTIAL.

HOSPITALS—PORTABLE EQUIPMENT

Information on this sheet was prepared by Ronald Allwork from data furnished by New York City Bureau of Architecture,

Dept. of Public Works, Isadore Rosenfield, Chief Architect—Hospitals, Joseph Blumencratz, Senior Architect—Hospitals.

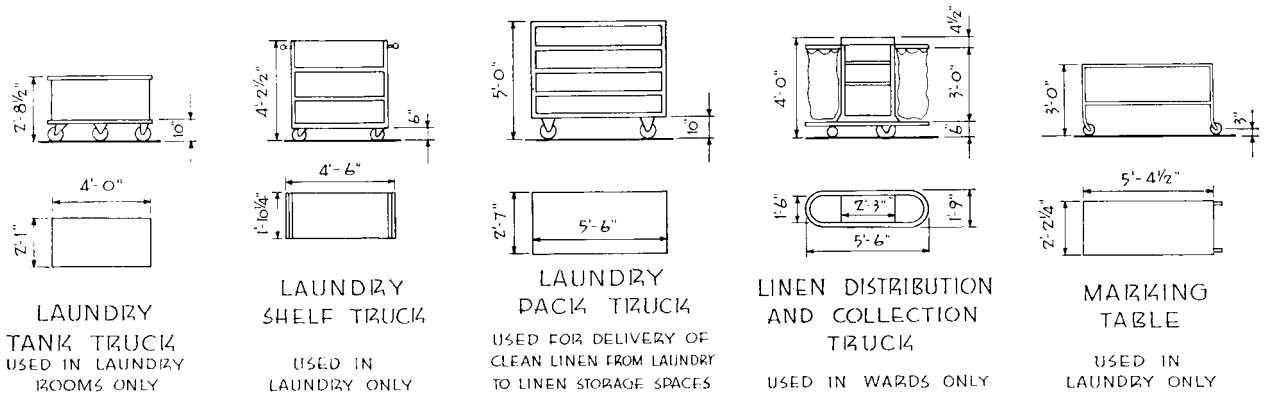

LAUNDRY VEHICLES

NOTE - EACH VEHICLE IS SHOWN IN PLAN AND ELEVATION
 SCALE OF ALL DRAWINGS ON PAGE 1/8" = 1'-0"

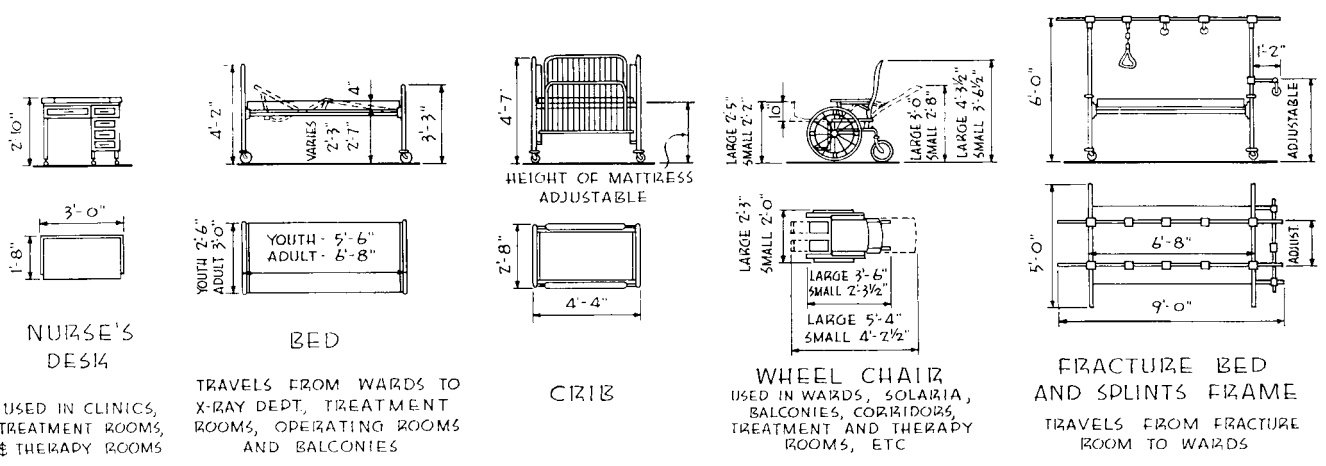
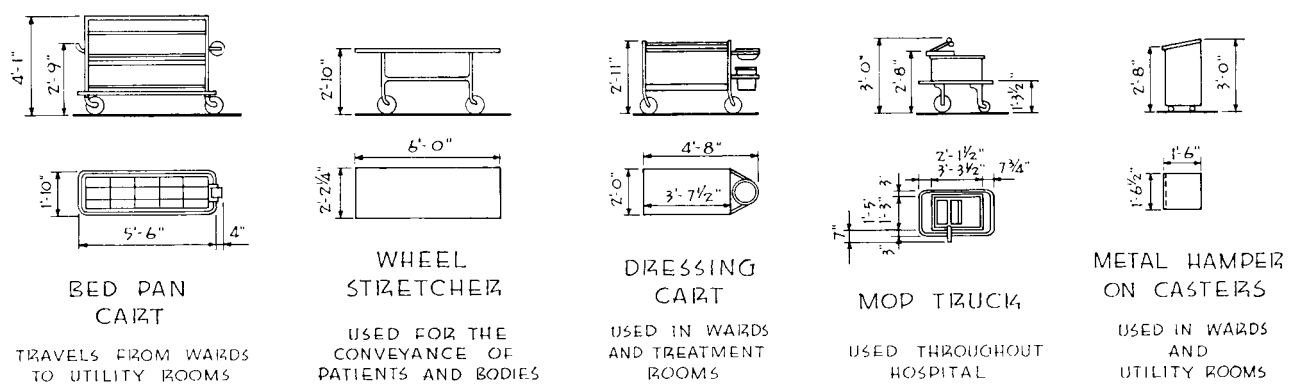

MISCELLANEOUS VEHICLES

HOSPITALS—PORTABLE EQUIPMENT

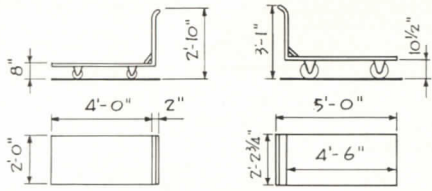

PLATFORM TRUCKS

USED THROUGHOUT HOSPITAL

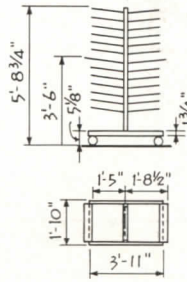

MIXED DOUGH
 RACK

USED IN BAKERY
 AND KITCHEN ONLY

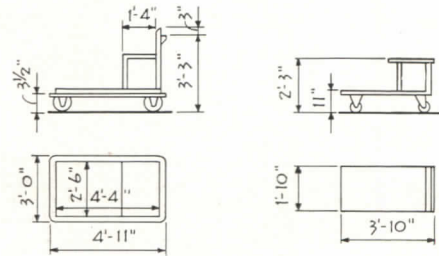

KITCHEN TRUCKS

USED IN KITCHEN ONLY

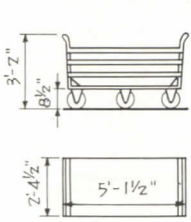

GENERAL
 UTILITY TRUCK

USED THROUGHOUT
 HOSPITAL

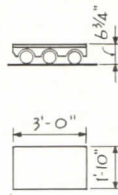

WOOD
 DOLLY

USED IN STORAGE
 AND RECEIVING
 ROOMS ONLY

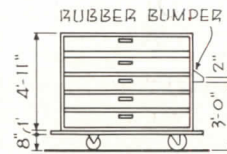

RUBBER BUMPER

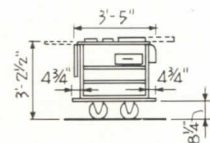

ELECTRICALLY
 HEATED
 TRAY CART

TRAVELS FROM DIET
 KITCHEN TO WARDS

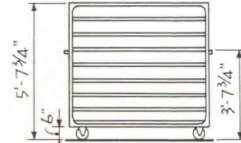

BUMPER PROJECTS

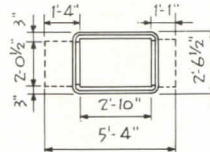

ENCLOSED
 ELECTRICALLY
 HEATED
 FOOD CART

TRAVELS BETWEEN
 KITCHEN AND WARDS

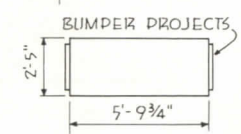

FINISHED
 PASTRY
 CART

USED IN BAKERY
 AND KITCHEN

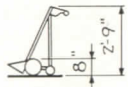

OXYGEN
 TANK TRUCK

TRAVELS FROM
 STORAGE TO WARDS

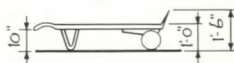

HEAVY DUTY
 HAND TRUCK

USED IN STORAGE
 ROOM ONLY

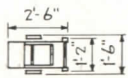

OPEN PLATFORM
 JACK

USED THROUGHOUT
 HOSPITAL

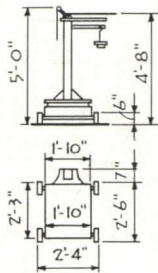

MOVABLE
 SCALE

USED IN STORAGE
 ROOMS AND KITCHEN

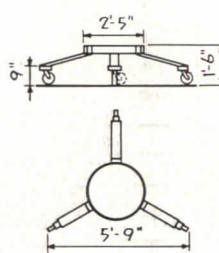

BOWL
 TRUCK

USED IN
 KITCHEN ONLY

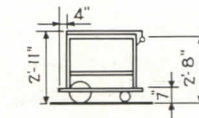

DISH TRUCK

TRAVELS FROM
 KITCHEN TO WARDS,
 CAFETERIAS, AND
 DINING ROOMS

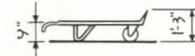

HAND
 TRUCK

USED IN
 KITCHEN ONLY

STORAGE ROOM VEHICLES

KITCHEN VEHICLES

EACH VEHICLE IS SHOWN IN PLAN AND ELEVATION
 SCALE OF ALL DRAWINGS ON PAGE 1/8" = 1'-0"