

# ARCHITECTURAL RECORD

COMBINED WITH AMERICAN ARCHITECT AND ARCHITECTURE

VOLUME 87

FEBRUARY 1940

NUMBER 2

## BUILDING NEWS

37

### NEW BUILDINGS

38-52

State Exhibit Building in Louisiana	38-41
Retail Nursery Store in California	42-44
School Chapel in Pennsylvania	45-48
Specialty Shop in California	49, 50
Milk Receiving Station in New Hampshire	51, 52

### NEW HOUSES (from two to four bedrooms)

53-66

Two-story House in Massachusetts	53-55
House of Many Levels, Oregon	56-58
Small Hillside Home, Northern California	59
Designer's Own Home, Tennessee	60, 61
\$4,950 Two-bedroom House, Southern California	62-64
Four-bedroom House at \$6,050, Louisiana	65, 66

### NEW HOUSE UNITS: VIEW WINDOWS

67-72

## DESIGN TRENDS

73

LANDSCAPE DESIGN AND THE PRIMEVAL ENVIRONMENT	74-79
---	-------

## BUILDING TYPES

81

### FACTORIES: DESIGN FOR MASS PRODUCTION

82-108

### CASE STUDIES

86-103

Toledo Scale Company	86-90
Allison Division, General Motors Corp.	91-95
Crown Can Company	96, 97
Cummins Engine Company	98, 99
English Chemical Factory	100-103

### TOWARD BETTER EMPLOYEE FACILITIES

104-108

(Index to Advertisements . . . Page 138)

Copyright, 1940, by F. W. Dodge Corp. All rights reserved.

## BEHIND THE RECORD

AN ARDENT ADVOCATE of the democratic principle once told us that if we drew a line 5½ ft. long on a blackboard and asked 100 representative persons to estimate its length, the average of the 100 estimates—though they ranged from 3½ to 7 ft.—would be 5½ ft.

Whereas our soapbox adventures never afforded an opportunity to make this particular test, we have from time to time employed variations of it. The most recent had to do with what 1409 architectural offices thought about various magazines in the building field. Because 1409 principals were interviewed personally we believe we obtained some figures which can be relied upon.

The first statistic to warrant mention was that among these 1409 offices, the RECORD has 11% more architect-and-engineer subscribers than any other architectural magazine in the country. Another was the vote on the "most helpful" magazines: readers having a preference gave 10% more votes to the RECORD than to any other magazine. And of all the features in the various magazines, the *Design Trends* and *Building Types* sections of

(Continued on page 7)

*Editorial Director:* Thomas S. Holden. *Editors:* Orville C. Anderson (*Managing*), James M. Fitch, Jr., Roger Wade Sherman. *Associate Editors:* Elisabeth Kendall, Irvin Kuper, Frank G. Lopez, Jr., George A. Sanderson. *Art Director:* Gene Hawley. *Desk Editor:* John W. Ragsdale.

*Editorial Consultant:* Michael A. Mikkelsen.

Architectural RECORD (combined with *American Architect and Architecture*) is published monthly by F. W. DODGE CORPORATION, 115-119 West 40th Street, New York. Truman S. Morgan, Pres.; Howard J. Barringer, Vice Pres. and Treas.; Irving W. Hadsell, Vice Pres.; Thomas S. Holden, Vice Pres.; Michael A. Mikkelsen, Vice Pres.; H. Judd Payne, Vice Pres.; Chauncey L. Williams, Vice Pres.; John M. Williams, Vice Pres.; Sanford D. Stockton, Jr., Secy.; Walter F. DeSaix, Asst. Treas.; Edwin H. Freed, Asst. Treas. Member Audit Bureau of Circulations and Associated Business Papers, Inc. Architectural RECORD is indexed in Readers' Guide, Art Index, and Industrial Arts Index.

Subscription Rates: United States and Possessions, Canada, Cuba, and Mexico. \$3 the year, \$5 for two years, \$6 for three years; Elsewhere, \$5 the year; Single copy, \$1. *Circulation Manager:* Robert C. MacDougall.

Manuscripts, photographs, and drawings which conform to RECORD'S editorial aims are welcomed. Every effort will be made to return material (if accompanied by stamped, addressed envelopes); but the editors will not be responsible for losses.

Other Dodge Services: REAL ESTATE RECORD, SWEET'S CATALOG FILES, HOME OWNERS' CATALOGS, DODGE REPORTS, and DODGE STATISTICAL RESEARCH SERVICE

# FOR CONCRETING CUT 29%

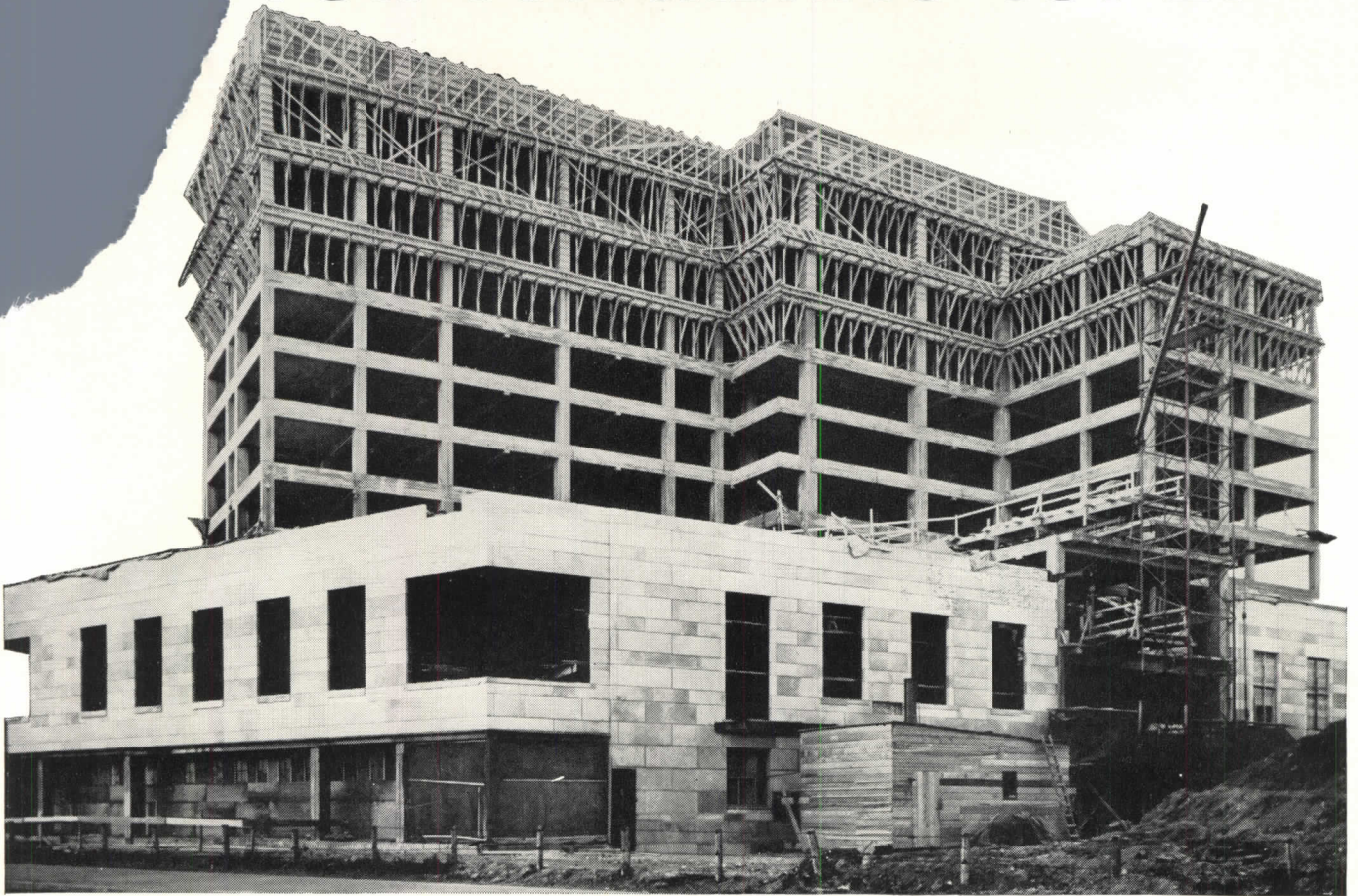

## Saved

24 days in winter concreting  
24 hours per floor in protection  
1 complete set of forms

Skyscraper home for 700 students at Northwestern University, Chicago, being rushed to completion with Atlas High-Early cement. Universal portland cement used on first three floors. Shift to Atlas High-Early cement has, so far saved 4 days per floor. Architect, James Gamble Rogers, New York; General Contractor, R. C. Wieboldt Co., Chicago.

## ... ALL WITH ATLAS HIGH-EARLY CEMENT

CONCRETING had been completed on but 3 stories of Northwestern University's new dormitory when cold weather set in. Winter construction plus necessity of completing this 18-story building on schedule prompted R. C. Wieboldt Co., the contractor, to shift from Universal standard portland cement to Atlas High-Early cement for the remaining 15 floors. Did it pay? What were the results?

Cylinder tests showed that the concrete attained over 2000 lb. strength in 3 days and over 3000 lb. in 7 days, as required. So forms were stripped in 10 days instead of 14—a saving of 4 days per floor, or 24 days in constructing floors 4 to 9 inclusive. Therefore, time for concreting was cut 29% with Atlas High-Early cement. In addition, time required for protection and curing was reduced from 48 to 24 hours, and costs

were cut as well. There were savings in form costs, too. Two complete sets of forms instead of 3 are doing the job. And plans call for continuing the construction with Atlas High-Early cement.

Consider Atlas High-Early cement on your next job. It saves time and promotes more economical construction on many jobs. Universal Atlas Cement Co. (United States Steel Corporation Subsidiary), Chrysler Building, New York.

# Atlas High-Early Cement

A UNIVERSAL ATLAS PRODUCT



AR-H-5

**BEHIND THE RECORD (continued)**

the RECORD topped the list in that order.

Other facts caught our eye (and some—such as the demand for more filable magazines—our private ear), but one point seemed especially significant: the advertising pages of the RECORD are more carefully scanned than those of any other magazine—average reading time for this purpose being 63 minutes. A statistically-minded staff member figures that this means a monthly total of 1,323,000 minutes of our reading public's time is devoted to finding out what's on the market.

**This month**

NEATLY SUPPORTING our editorial hunch for this month's *Building Types* subject matter—Factories—comes a statement by Pennsylvania's Commerce Secretary, Richard P. Brown, that expenditures in that state on plant construction and equipment totaled \$194,846,109.00 for 1939. "This figure is more than twice as large as . . . in any recent year". . . . In *Design Trends*, Messrs. Eckbo, Kiley, and Rose complete the last of their series of studies on landscape design. So widely recognized has the series become that the RECORD plans to reprint them in pamphlet form. . . . In *Building News* a permanent exhibit building for a state fair, a retail store for nursery stock, and a Pennsylvania chapel supplement 20 pages of new houses and house units.

**Next month**

BUILDING NEWS will lead off with Miami's newest and most newsworthy hotel, incorporating many features which merit consideration far north of the palm and hibiscus; a small hillside apartment group from California; the "home office" of one of the North-

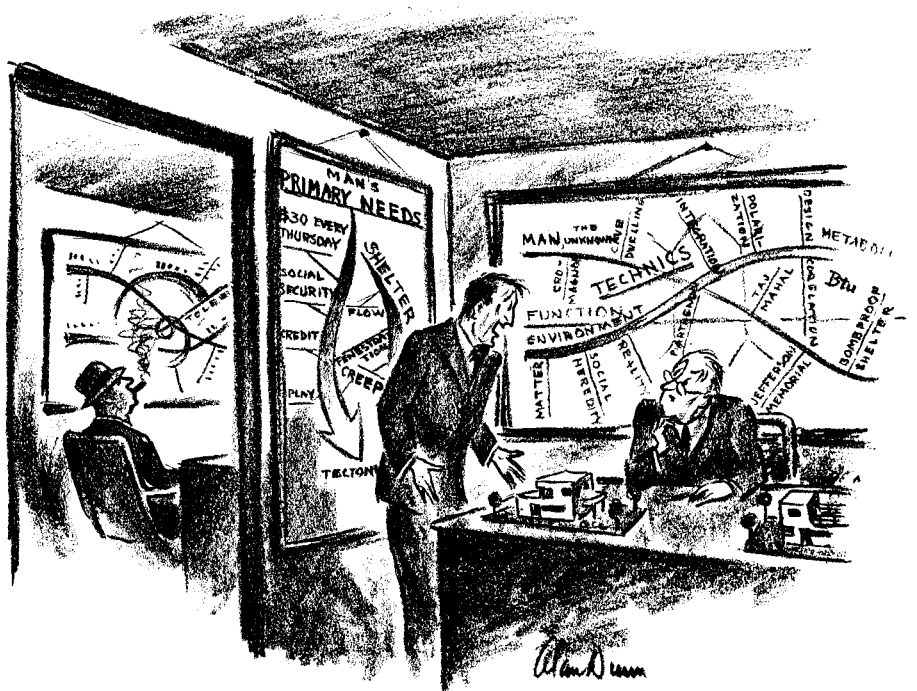

"What do I do now? . . . He says that wherever he hangs his hat is home to him."

—Drawn for the RECORD by Alan Dunn

west's most progressive Bishops; and a specialty shop in Manhattan—plus 16 pages of special-use houses. . . . *Design Trends* has scheduled an analysis of the survey we've just made of what recent architectural graduates are doing, would like to be doing, and think the schools should have done for them. Trenchant stuff! . . . In the first of its three 1940 studies on houses, *Building Types* will analyze sanitation, circulation, light, sound, and heating and ventilating as they affect house design and illustrate its points with appropriate case studies.

**Even better than we thought**

LOUIS H. GERDING, whose school we ran in January (pp 35-38), writes that his office accidentally quoted us a cost on the job which was \$100,000 *too high!* Figure should have been \$200,000. . . . On page 12 of our

December issue the credit for the design of the First Baptist Church in Denver should have included the firm of Merrill, Humble, and Taylor as consulting architects.

**Season's Greetings**

ARCHITECT RHEES BURKET sends us his version (see below): 1. Doll house design for friend. 2. First scheme for client's house. 3. Second scheme—something wrong. 4. Approved plan. 5. Elevation—not approved.\* 6. Plan for swank bar—a 10% job. 7. Apartment project; business is good. 8. Design for shop; business is excellent.\*\* 9. Pencil broken in rage. 10. Self portrait, Dec. 24. 11. T-square—easy to draw. 12. Seeing double Xmas trees, Dec. 25. 13. Self portrait in dog house. 14. Jan. 1.—Hope renewed.

\*Project abandoned. \*\*All projects abandoned as of December 23, 1939.

**INDEX TO DRAWINGS**

1. DOLL HOUSE DESIGN FOR FRIEND.
2. FIRST SCHEME FOR CLIENT'S HOUSE.
3. SECOND SCHEME (SOMETHING WRONG).
4. APPROVED PLAN.
5. ELEVATION (NOT APPROVED).
6. PLAN FOR SWANK BAR (A 10% JOB).
7. APARTMENT PROJECT (BUSINESS IS GOOD).
8. DESIGN FOR SHOP (BUSINESS IS EXCELLENT).
9. PENCIL BROKEN IN RAGE.
10. SELF PORTRAIT, DEC. 24.
11. T-SQUARE—EASY TO DRAW.
12. SEEING DOUBLE XMAS TREES, DEC. 25.
13. SELF PORTRAIT IN DOG HOUSE.
14. JAN. 1.—HOPE RENEWED.

**LEGEND**

ARCHITECTS IS THE NEAREST  
PEOPLES—ESPECIALLY AT  
CHRISTMAS TIME.

**CHRISTMAS**

DATE: \_\_\_\_\_ DRAWN BY: Rhea Burket

# ANNOUNCING

## Silence without screens, shot or mufflers



### INDEPENDENT LABORATORY TESTS

show Watrous **SILENT-ACTION** eliminates 88.5% of flush valve noise

• In order that those who buy, specify and install flush valves might have definite, unbiased information as to the efficiency of Watrous **SILENT-ACTION** Flush Valves in eliminating noise, Imperial submitted these flush valves for test to a nationally known, independent research laboratory (name on request).

The report of this laboratory, based upon tests in which the most efficient

sound recording instruments were used, shows that Watrous **SILENT-ACTION** reduces ordinary flush valve noise energy an average of 88.5%.

The tests also indicated that even after the valve had been used for a long period of time with water having considerable suspended matter in it, the noise level of the valve did not increase.

**NOISE ENERGY** generated by ordinary Flush Valve

100%

Noise energy remaining when Watrous **SILENT-ACTION** Equipment is used

← 11½%

FOR FURTHER  
INFORMATION  
SEE OUR  
CATALOG IN  
SWEET'S

THE IMPERIAL BRASS MFG. CO., 1240 W. Harrison Street, Chicago, Ill.

ARCHITECTURAL RECORD

# in the new **SILENT-ACTION** Watrous Flush Valve

**H**ERE is the most significant development ever made in the silencing of flush valves.

Watrous SILENT-ACTION Flush Valves, for the first time in the history of the industry, completely eliminate all objectionable flush valve noise without the use of screens, shot, mufflers, or other elements which readily become clogged.

The dramatic effectiveness of these valves in the elimination of noise has been proved by the tests of a nationally known, independent testing laboratory as described on the opposite page. These tests show that Watrous SILENT-ACTION eliminates an average of 88.5% of flush valve noise.

The advantages of Watrous SILENT-ACTION — with its complete absence of screens to clog — include:

(1) Silent operation that stays silent.

(2) No need for frequent adjustment of stop to compensate for gradual clogging (such as occurs when screens are employed).

(3) No parts requiring frequent replacement or cleaning.

All types of Watrous Flush Valves—Majestic, Imperial and Jewel—can be furnished complete with SILENT-ACTION equipment. The Watrous SILENT-ACTION Shut-off can also be applied to old installations of any make of flush valve.

You will be interested in getting complete information on how flush valve noise can be *permanently and efficiently* eliminated in hospitals, institutions, apartments, offices, hotels and schools. Write for your copy of "A Scientific Method of Silencing Flush Valves."

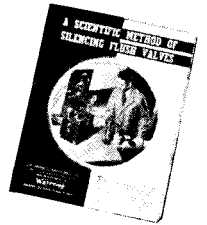

● This patented, corrugated dispersion silencing element inside the Watrous SILENT-ACTION Shut-off does the bulk of the silencing job. It not only eliminates all objectionable line and shut-off noises, but by quieting water flow to flush valve, also substantially reduces both bowl and closing noises. **NOTE THAT NO SCREENS WHATSOEVER ARE USED.**

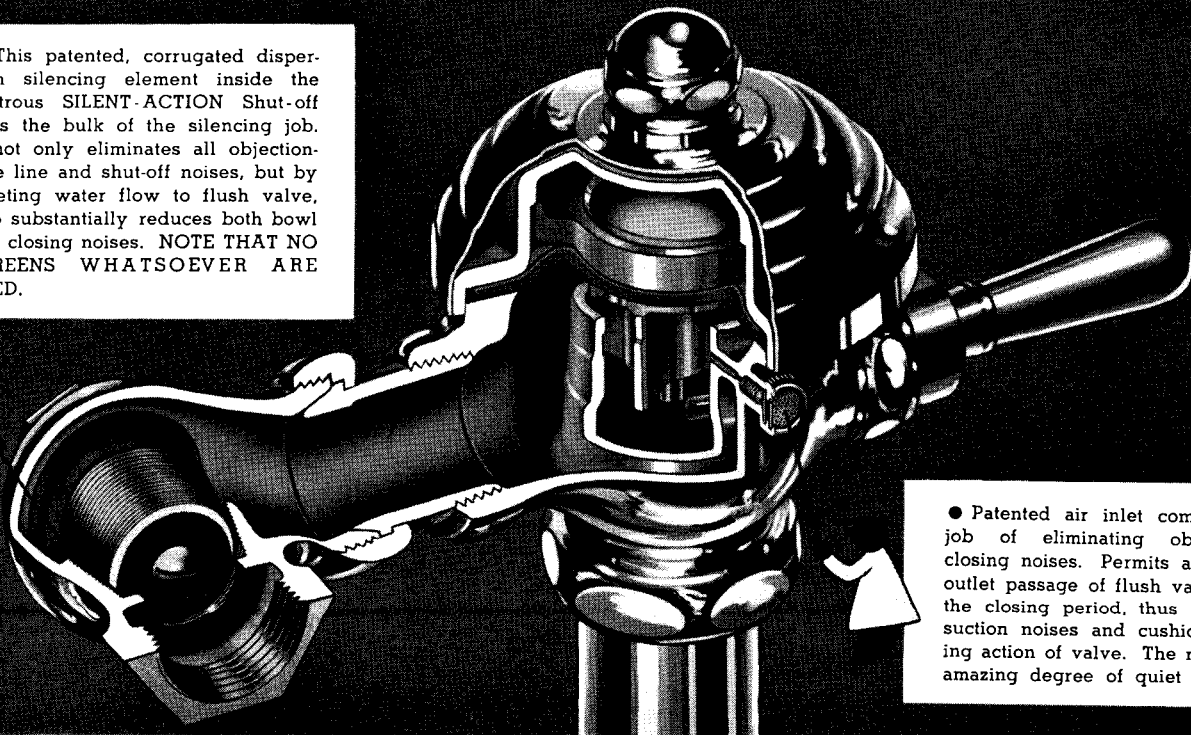

● Patented air inlet completes the job of eliminating objectionable closing noises. Permits air to enter outlet passage of flush valve during the closing period, thus eliminating suction noises and cushioning closing action of valve. The result is an amazing degree of quiet in closing.

Watrous SILENT-ACTION can be obtained in both Watrous diaphragm type and piston type flush valves.

**Sole manufacturers of Watrous Flush Valves and Imperial Vacuum Breakers**

## WITH RECORD READERS

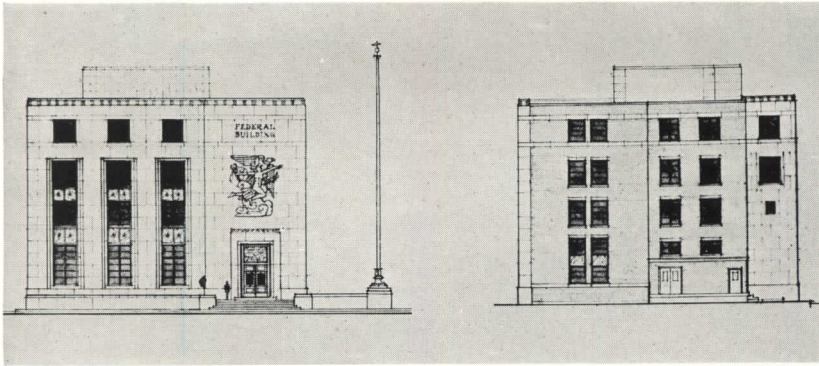

Main facade and rear elevation.

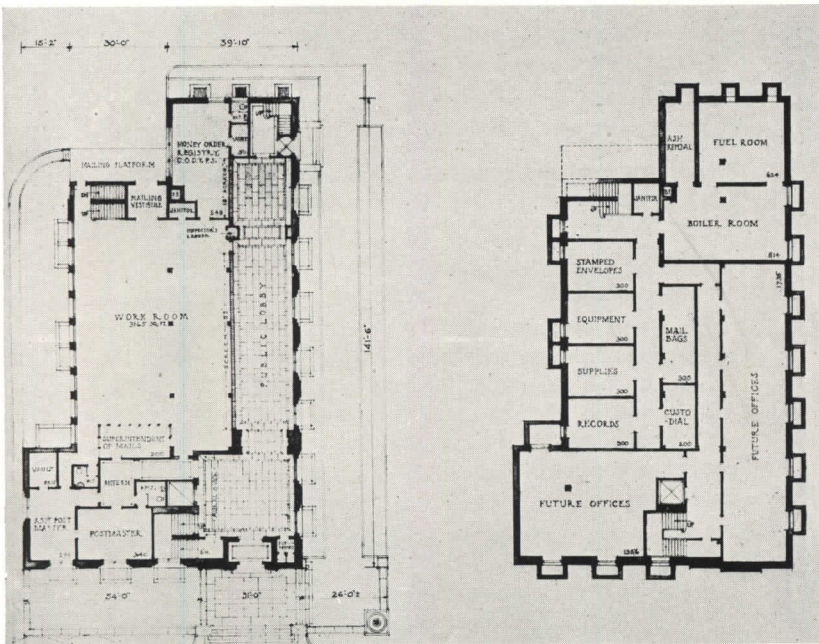

Above: first floor and basement. Below: second, mezzanine, third floors.

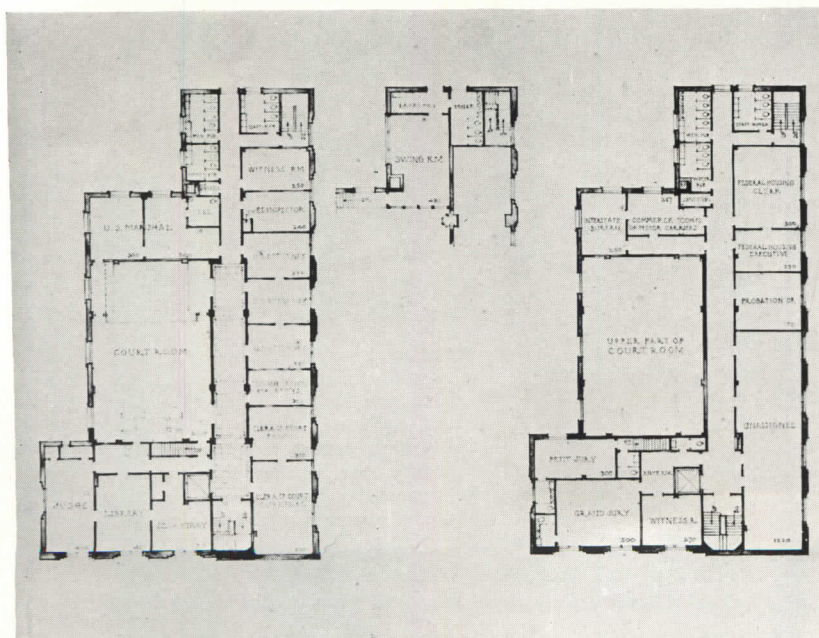

WINNING DESIGN: Submitted to Jury as Number 20, by Frederick Mathesius, J. A. Thompson, and G. A. Holmes, Associated Architects.

## Jury Names Winners in Montpelier Post Office Design Competition

DESIGN No. 20, later unveiled as the work of *Fredrick Mathesius, John A. Thompson, and Gerald A. Holmes*, Associated Architects of Stamford, Conn., was unanimously chosen winner in the competition for a Post Office and Court House at Montpelier, Vt. This was the third in the series of competitions conducted under the auspices of Federal Works Administrator *John M. Carmody*, to select architects for proposed Federal buildings.

Seventy-four entries were submitted by architects with home offices in Region No. 1, defined by Secretary Morgenthau's plan of March 1939 (see AR 5/39, p. 10) to embrace Maine, Vermont, New Hampshire, Massachusetts, Rhode Island, and Connecticut. In addition to designating the winner, the Jury composed of *Sherley W. Morgan* of Princeton, N. J., Chairman, *George Bain Cummings* of Binghamton, N. Y., *Alfred V. du Pont* of Wilmington, Del., *Edward B. Green* of Buffalo, N. Y., and *Charles T. Ingham* of Pittsburgh, Pa., also recommended that the three designs pictured on page 12 be awarded honorable mention. The authors of the winning design received a fee of \$4,000 and will be paid an additional \$4,000 as consultants to the Office of the Supervising Architect in the preparation of actual working drawings and specifications. If for any reason the winners are unable to serve in this capacity, the jury voted that honorable-mention design No. 45 be considered the First Alternate, and that its authors, the *Thomas M. James Co.* of Boston, Mass., succeed as consultants.

In addition to an estimated cost of \$400,000 for the proposed building, other conditions were that it should be limited to an absolute maximum of 650,000 cu. ft.; that because of its proximity to the Rutland marble quarries and the granite works at Barre, stone would be chosen as the material; and that mechanical ventilation be employed and the necessity of outside light obviated.

Other plan elements for which the Jury were looking included: "unobstructed and well-lighted work space, and adequate lobbies and circulations, both horizontal and vertical." In elevation they hoped to find "a building of simple yet interesting mass placed so as to take advantage of the possibilities of the site."

It was also contemplated that "the building would consist of four stories." This last provision, though not mandatory, was in general so scrupulously observed that it led all the proposed solutions to affect the Jury with, in their words, "a rather monotonous uniformity." The interesting site possibilities "might well have suggested a more unusual concept."

In commenting on the winning design specifically, the Jury were agreed that it was superior in meeting the majority of these conditions. Although a number of weaknesses were recognized, it was felt that further study could easily eliminate them.

# FREE to ARCHITECTS and BUILDERS

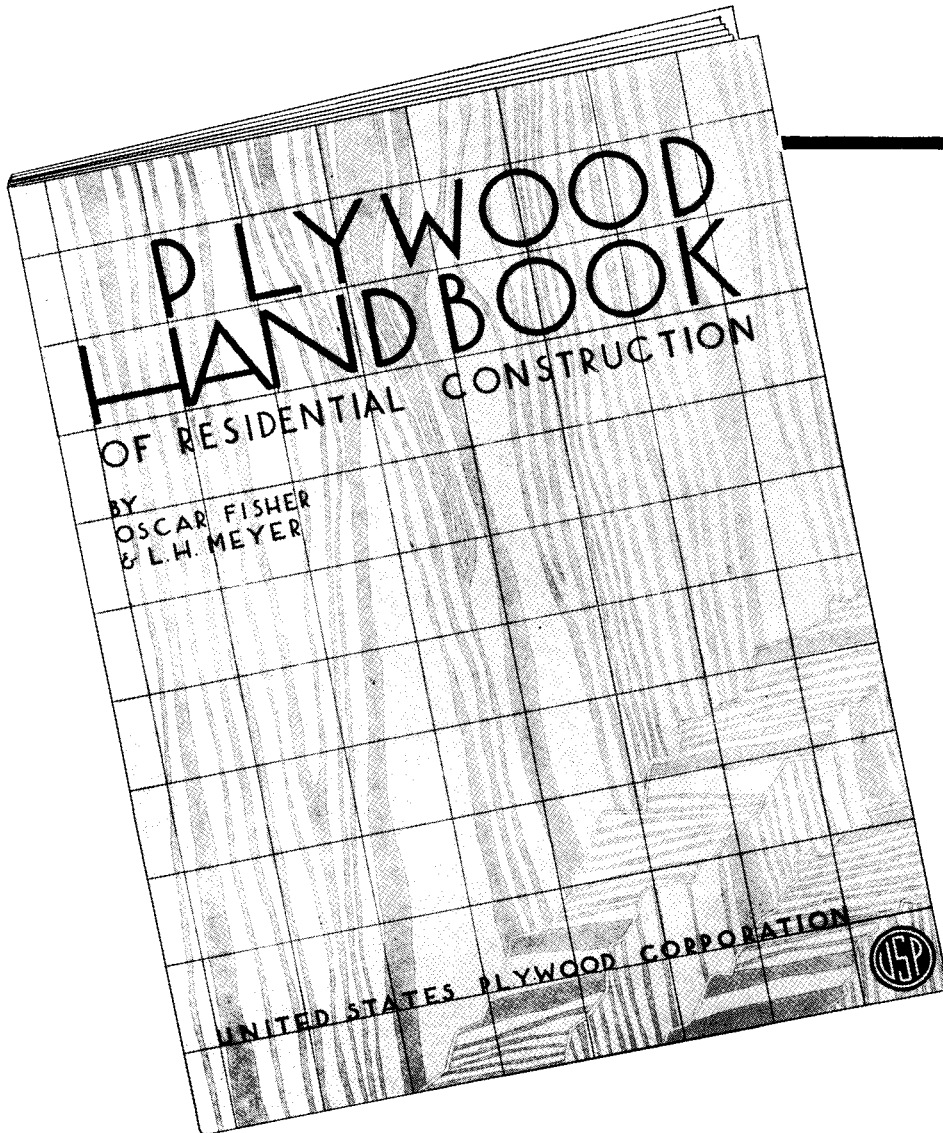

## The Plywood Handbook

summarizes the *field* experience of *practical* men in the erection of all-plywood houses. It explains the fundamental steps in design and development and includes draughting details such as

● EXTERIOR and INTERIOR CORNERS and JOINTS, DATA on INSULATION and MOISTURE BARRIERS, NAILING and FINISHING.

The TYPICAL PLANS and renderings of \$2,000, \$3,500 and \$5,000 HOUSES with outline SPECIFICATIONS and COST BUDGETS will serve as a sound basis from which designers can develop individual ideas.

One hundred illustrations make the Plywood Handbook a clear, concise and invaluable aid to the practical man.



## FREE

A note on your letterhead or business card will bring this 40 pp. 8½" x 11" booklet

## FREE

## UNITED STATES PLYWOOD CORPORATION

Producers of

### WELDBORD

*DeLuxe Blue Label*

FOR interior trim, in bright finish or under paint, enamel or wallpaper.

### WELDWOOD

*Waterproof Plywood*

FOR Siding or any other outdoor use.

### DOUGLAS FIR

*the all-purpose Plywood*

FOR cabinets, under-flooring, sheathing, wallboard and built-ins.

EXECUTIVE OFFICES: 616 WEST 46TH STREET, NEW YORK, N. Y.

BRANCH OFFICES AND WAREHOUSES IN PRINCIPAL CITIES

## WITH RECORD READERS (Montpelier Competition, continued)

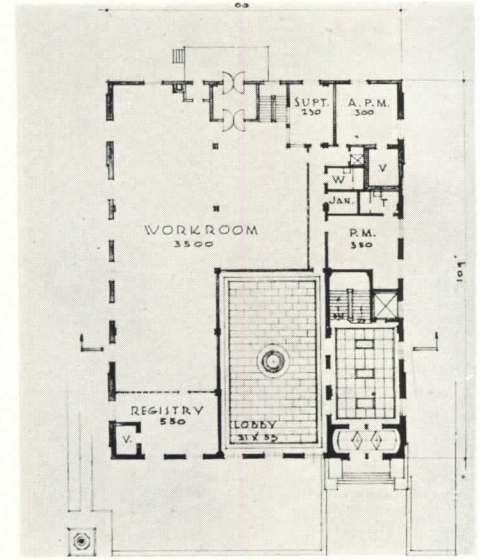
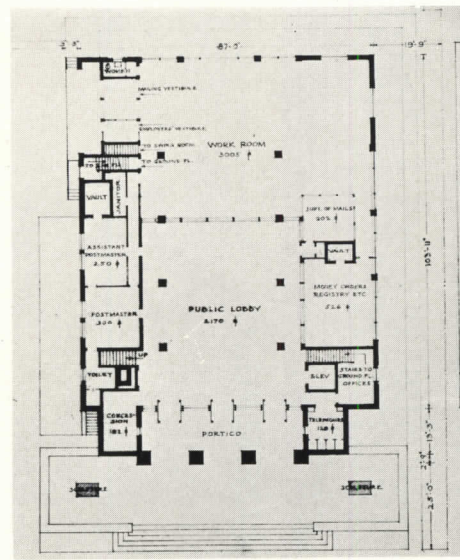
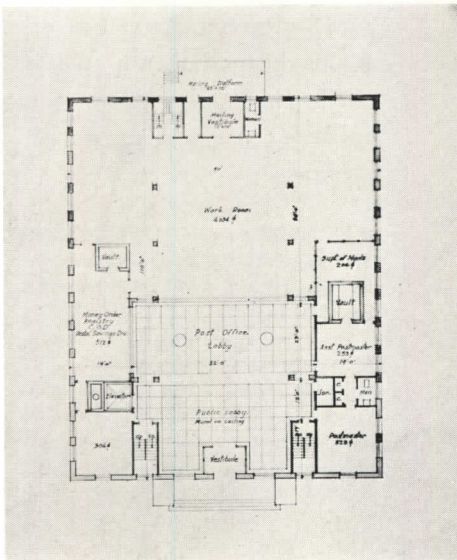
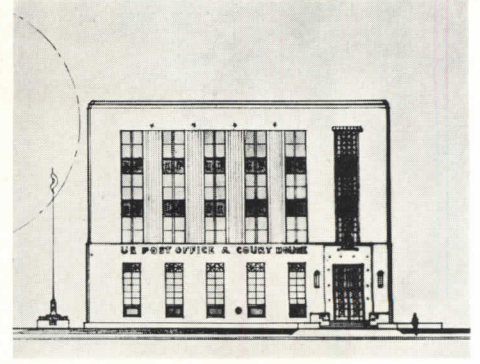
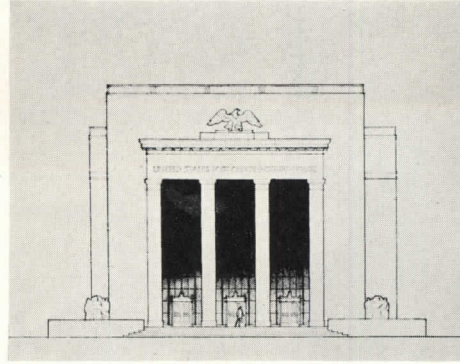
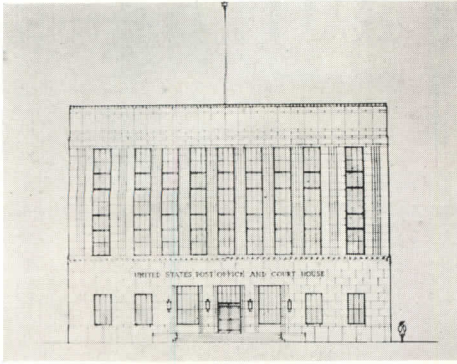

Top, main facade; bottom, first floor.

**HONORABLE MENTION:** Submitted as Design #45, by Thomas M. James Company, Architects, Boston, Mass.

Top, main facade; bottom, first floor.

**HONORABLE MENTION:** Submitted as Design #54; prepared by Raphael Hume, Architect, of Stamford, Conn.

Top, main facade; bottom, first floor.

**HONORABLE MENTION:** Submitted as Design #11, by Austin & Austin, and E. J. Ryan, Archts., Burlington, Vt.

### Winners of West Coast P. O. Design Competition Announced

ULYSSES FLOYD RIBLE of Beverly Hills, Calif., will receive \$1,500 as author of the winning design for a new Post Office building at Burlingame, Calif. Later, as consultant to the Office of the Supervising Architect, he will be paid \$1,500 more. *W. E. Reynolds*, U. S. Commissioner of Public Buildings, also announced, in connection with this competition, that Federal Works Administrator *John M. Carmody* had approved the Jury's recommendation of honorable-mention awards to the following: *Harry M. Michelsen*, San Francisco; *John Ekin Dinwiddie*, San Francisco; and *Graham Latta*, Architect, *Whitney R. Smith*, Associate, of Glendale, Calif. The Jury in the case consisted of *E. F. Lawrence*, Portland Oreg.; *Burnham Hoyt*, Denver; and

*R. H. Cameron*, of San Antonio, Tex.

The Burlingame Post Office, with an estimated cost of \$150,000, fourth project in the series of regional competitions, attracted 132 entries from California, Nevada, and Arizona, the states comprising Region No. 11. In an early issue, *Pencil Points* will present plans and elevations of the winning design and the runners-up, in accordance with the trilateral agreement existing among that magazine, *Architectural Forum*, and the RECORD to alternate in publishing detailed accounts.

Commissioner Reynolds, commenting on these competitions in general, observes: "Under this program a new effort is being made to enlist the full strength of the Nation's architectural

skill in designing Government buildings. . . the competing architects are governed by the provisions of a program issued to qualified competitors by the Public Buildings Administration. These provisions . . . are the result of extensive study of . . . the highly specialized needs of the Governmental Departments involved, the comfort and convenience of the public, the size and character of the building site, and the traditions and tastes of the community.

"The finally accepted design, therefore, is no haphazard thought of some individual as to what might look well in this particular location, but rather the inevitable result of technical, geographical, and social factors, skillfully correlated in a unified design."





IT'S "COLD COMFORT"  
for the Architect

*... when he, alone, remembers that his structure was "fireproof!"*

AFTER a building is destroyed by fire, no one credits the architect for employing fire-proof design. For, the best concrete-and-metal construction soon crumbles when fire feeds on inflammable materials stored within.

It takes but one added precaution to prevent such disaster. Call a Grinnell engineer before plans reach the blueprint stage. Incorporate automatic sprinkler fire protection that will *stop fire at its source!* On guard twenty-four hours a day, these systems have put out over 8,000 incipient fires since 1930.

By working with Grinnell, you obtain undivided responsibility from the world's leader in fire protection.

Every valve, fitting and sprinkler head is engineered by Grinnell . . . every pipe is pre-cut to your plans. And Grinnell's 60 years' experience aids you not only in planning efficient installation, but also in harmonizing fire protection with architectural design.

Consult Grinnell for full details. No obligation. Grinnell Company, Inc., Executive Offices, Providence, Rhode Island. Branch offices in principal cities of United States and Canada.

**GRINNELL**  
AUTOMATIC SPRINKLER FIRE PROTECTION

*If it isn't Sprinkler-Equipped, it isn't Fireproof!*

# L. C. SMITH & CORONA TYPEWRITERS, INC. CUTS HEATING COSTS

Webster Moderator System Helps  
Groton, N. Y. Plant to Slash  
Coal Consumption 20 P.C.

SAVES \$1,151.83 IN ONE YEAR

Maintains Desired Temperatures  
in Manufacturing and Storage  
Sections, Offices, Gymnasium

COMFORT IN COLDEST WEATHER

Groton, N. Y.—Coal consumption in the Groton Plant of L. C. Smith & Corona Typewriters, Inc., has been reduced approximately 20 per cent as the result of a Webster Heating Modernization Program.

A preliminary survey of the heating system in this modern plant was carried out in 1937. As a result, a Webster Moderator System of Steam Heating was installed to correct steam circulation difficulties and cut fuel costs.



The new Corona Typewriter

The Webster Moderator System maintains desired temperatures in manufacturing sections, offices, storage sections, gymnasium and club rooms.

It was originally planned to allow the modernization program to pay for itself out of fuel savings. After two years of satisfactory results, it was decided to close the transaction for cash.

There is a total of 20,673 sq. ft. of installed direct radiation in the Groton Plant of L. C. Smith & Corona Typewriters, Inc.

A feature of the modernization program was the equipping of 24 coils with Webster Process Steam Traps and Webster Dirt Strainers.



## LOW HEATING COST

GET THIS BOOK . . . Read the fact stories about economy and comfort in the heating of 144 buildings. No exaggerated claims. No promises. Just 64 pages of heating results. Ask for "Performance Facts."

WARREN WEBSTER & CO., Camden, N. J. Pioneers of the Vacuum System of Steam Heating Representatives in 65 principal U. S. Cities—Est. 1888

## WITH RECORD READERS



### Mark Daniels, AIA, Presents Plan for Chinatown Housing

BELIEVING THAT the "atmosphere" of San Francisco's famous Chinatown was getting a bit too thick, the Junior Chamber of Commerce in that city recently unleashed a drive for a housing project in "the greatest Oriental colony outside Asia". Architect *Mark Daniels*, AIA, Northern California Chapter, was called upon by the Chamber committee to draw up a possible solution to the problem. Two major evils were involved. First and worst is that 20,000 Chinese are stuffed into an area of 20 scanty city blocks. A rocketing mortality rate and a steadily gathering threat of plague are the natural results. Second is that this "exotic city within a city" has rapidly been losing its traditional character.

Mr. Daniels' proposed housing unit, pictured above, would remedy the first condition by resettling eighty families, with three rooms to each apartment. The not incongruous multistory block-type plan, achieving vertical expansion, would relieve the unhealthy congestion hitherto caused by space limitations. Modeled after the lamasary at Lhasa, sacred Buddhist city of Thibet, the unit, and others to be patterned on it, would also serve to re-establish the essential Oriental character of Chinatown and, it is hoped, stimulate the inhabitants to resist the imposition of incompatible alien forms.

### \$1200 Brunner Scholarship Offered by New York AIA

BETWEEN THE DATES of February 1st and April 1st, the New York Chapter of the AIA will receive applications

for the first Arnold W. Brunner Scholarship, established through bequest by the widow of the late Arnold W. Brunner, New York architect.

Award may be made to citizens of the United States engaged in the profession of architecture, regardless of place of residence. Candidates must have adequate professional background, more advanced and broader in scope than is generally implied by undergraduate architectural school training. They are required to submit their qualifications on blanks available for the purpose, together with briefs or outlines of their proposed studies in the field of investigation assigned, which for 1940 is: "A comparative study of the influence of local conditions on regional architecture in the United States—An analysis of the practical effects of geographic and social factors on past and present building."

The \$1,200 scholarship will be awarded to that candidate who, in the opinion of the New York AIA Com-

(Continued on page 114)

### CALENDAR OF EVENTS

- February 1—March 1—Reception of proposals of candidates for Langley Scholarships, American Institute of Architects, 1741 New York Ave., N. W., Washington, D. C.
- February 14-26—Exhibition of water-colors by Samuel Homsey, Associated American Artists' Galleries, New York City.
- March 1—Closing date, reception of applications for Lowell M. Palmer Fellowship. Application blanks obtainable from Secretary, School of Architecture, Princeton University, Princeton, N. J.
- March 4-15—Fifth Pan-American Congress of Architects, Montevideo, Uruguay.

**M** *Tip to Progressive Architects:*

**More millions of American families prefer Scott Tissues than any other... why not give your clients this same superior service?**

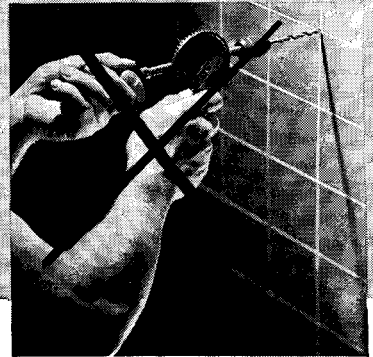

**NO DRILL HOLES** MAR walls when fixtures are installed with Scott Special Adhesive. Installations are completed rapidly. Fixtures stay up securely, yet can be quickly relocated at any time.

**2 OUT OF EVERY 5** American families choose Scott Tissues or Scott Towels for home use. Most of your clients come from this discriminating group. Specify fixtures for ScotTissue when you're planning washrooms for industrial or commercial buildings. Clients appreciate this mark of considerate washroom service. And they enjoy steady savings, for ScotTissue is a roll tissue... longer-lasting and more economical.

**Use the Scott Advisory Service for More Efficient Washrooms**

You can make any washroom more

comfortable and efficient by using this valuable Scott Service. Experienced Scott representatives know how many fixtures are needed to prevent congestion... where to place them for greatest convenience. Consultations cost nothing... will help you plan modern washrooms that combine low operating costs with highest quality tissue and towel service.

#### **Plan for Better Public Relations**

Sanitary towel service is vital in your clients' Industrial and Public Relations. That calls for "Soft-Weve" ScotTissue Towels and Scott cabinets in your specifications. These soft, cloth-like tissue towels are favorites with men and women alike. Because

ScotTissue Towels dry drier and go farther, they cost less in service.

For details on these Scott products and complete information on the Scott Washroom Advisory Service, consult Sweet's Catalog or write Scott Paper Co., Chester, Pa.



# ScotTissue

Trade Marks "Soft-Weve," "ScotTissue" Reg. U.S. Pat. Off. Coppr., 1940, Scott Paper Co.

**WITH RECORD READERS (San Francisco Survey)**

Photos by Gabriel Montlin



**FIVE VOTES:** Furniture Exchange and Merchandise Mart. Designed and built by the Bank of America Capital Co.

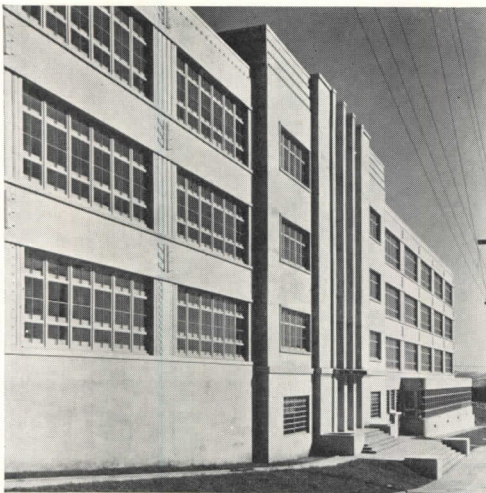

**FOUR VOTES:** George Washington High School. Miller and Pflueger, Architects.



**THREE VOTES:** Federal Building in the San Francisco Civic Center. Arthur Brown, Jr. was the architect.



**THREE VOTES:** Telenews Movie Theater for which Albert F. Roller was architect.



**THREE VOTES:** United States Government Mint. The architect was Gilbert Stanley Underwood of Washington, D. C.

(Continued from page 16)

dent; *Bernard H. Muldary*, lawyer; the *Rt. Rev. Edward L. Parsons*, clergyman; *Thomas Rolph*, broker; *M. H. L. Sanders, Sr.*, investment securities; *Arthur Skaije*, executive; *Ralph Stackpole*, sculptor; *Charles Suydam*, executive; *Harold Wallace*, interior decorator.

Following buildings get honorable mention: Ferris Bagley residence (*John Dinwiddie*, Architect), Grace Cathedral (*Lewis P. Hobart*), Insurance Co. of North America (*Harry A. Thomsen, Jr.*), Lawton Grammar School (*Mario J. Ciampi*), Mariana Junior High School (the late *George W. Kelham* and *William P. Day*), Auditorium by *H. A. Thomsen, Jr.* and *W. P. Day*, Roos Bros. Store (Exterior: *Bliss & Fairweather*. Interior: *A. R. Williams*), Santa Fe Bus Terminal (*H. L. Gilman*, Los Angeles), Top of the Mark Cocktail Lounge (*T. L. Pflueger*).

# BUILDING NEWS



*Roger Sturtevant*

**New Houses and New House Units . . . see pp. 53-72**

ARCHITECTURAL  
RECORD



# LOUISIANA'S PERMANENT EXHIBIT BUILDING

The state fair is one of America's oldest and most popular institutions. Yet the physical plants of these regional fairs are seldom either structurally admirable or esthetically satisfying. Quite in contrast is the new Louisiana State Exhibit Building, recently completed in Shreveport by Architects EDWARD F. NEILD, D. A. SOMDAL, and EDWARD NEILD, JR. Adjacent to, but separate from, the State Fair grounds, this exhibit building constitutes a year-round display of the State's manifold activities.

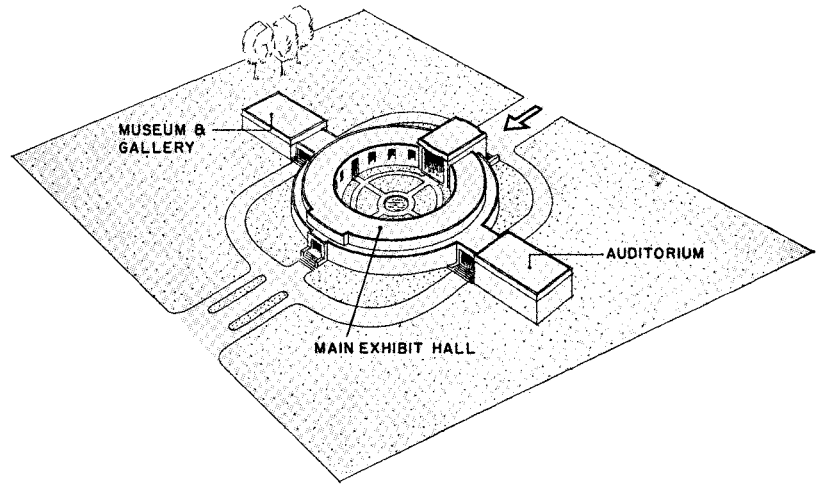

THE MAIN EXHIBIT BUILDING is a huge circular structure, surrounding a central court 116 ft. in diameter. To the right and left are the subsidiary buildings—the museum and auditorium—connected to the central building by covered foot passages.

The impressive pair of elliptical columns at the main entrance are granite monoliths. The rest of the exterior of the group is of Indiana limestone, except for the covered passages to the two wings which are surfaced in Texas pink granite. An aluminum grille surmounts the central door at the back of the portico. Above the other two doors and on the portico end walls are frescoes by Conrad Albrizio symbolizing the northern and southern sections of the state. Construction is reinforced concrete frame with brick and hollow-tile backing for masonry. Roofs are covered with Barrett built-up roofing.

The large main lobby, shown at right, below, has walls of St. Genevieve Rose marble, above a base of Coral Rouge Fleuri marble. The floors are terrazzo. In the center is a well, 15 ft. in diameter, which contains a relief map of Louisiana, illuminated by a ceiling spotlight.

At the far side of the lobby, doors lead out to the open courts. A pool occupies the center position, with the rest of the area laid out in walks and gardens. The planting is to be a living exhibit of indigenous shrubs and flowers. Cost of the building, exclusive of landscaping, was \$483,690, shared by PWA and the State of Louisiana.

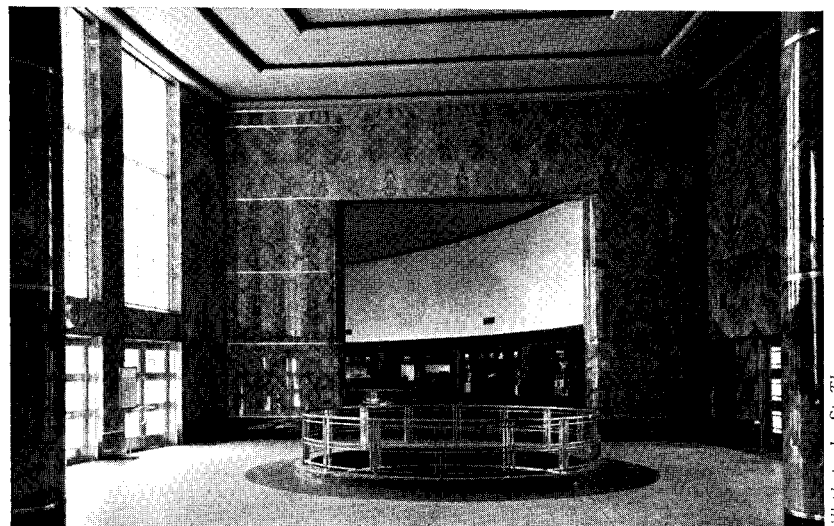
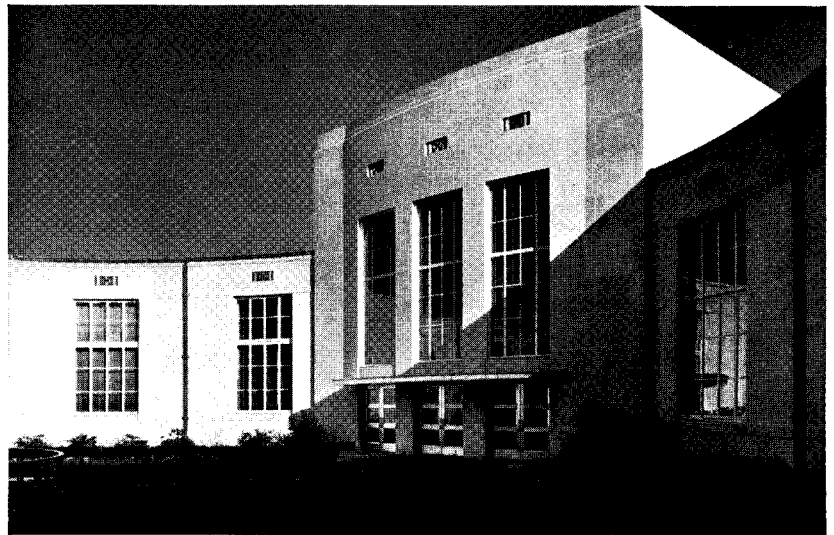

At top: the court side of the entrance lobby. Bottom: the lobby itself.

All photos by St. Thomas

## LOUISIANA EXHIBIT BUILDING

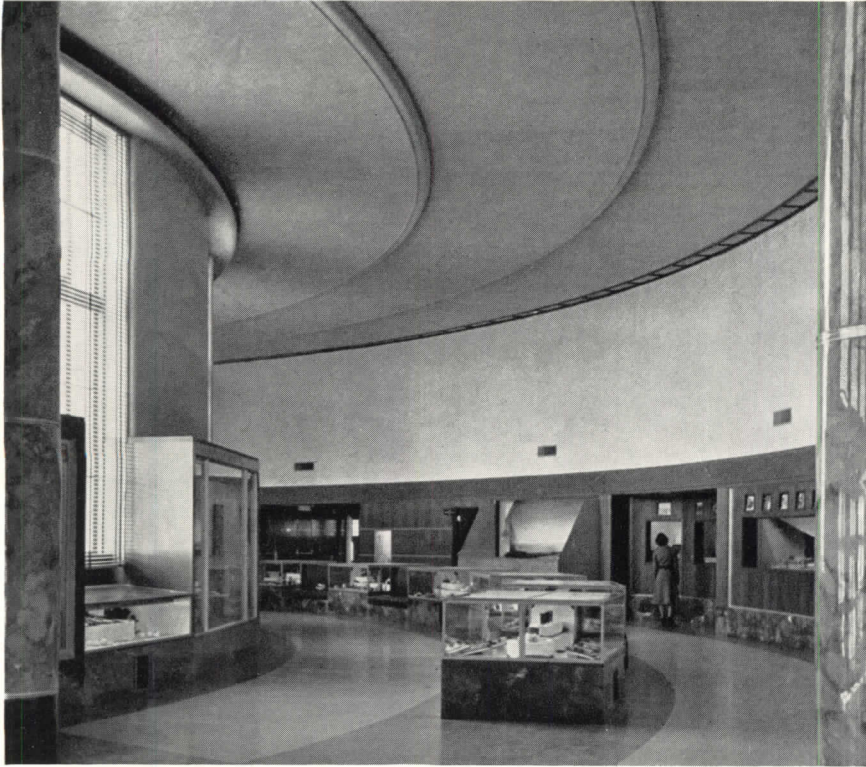

View of the display concourse. Cases by Flour City Ornamental Iron Company.

LINING THE EXTERIOR WALLS of the display concourse are 26 cases, with access from the rear. Here are small-scale dioramas depicting the industry and agriculture of the state. Island cases and display cases against the court wall contain the actual products resulting from the enterprises shown in adjoining dioramas.

Above the dioramas is an 11-ft. plaster wall which extends around the full circumference of the building, except where it is interrupted by the entrance lobby. This area, 600 ft. in length, will ultimately be covered with a continuous photomural. All lighting in the display area is indirect, and the ceilings have Johns-Manville acoustical treatment.

The museum wing contains a small art gallery and historical museum. The auditorium, seating 350, has a projection room and small stage. Most of the building is only heated and ventilated, but this room is entirely air-conditioned.

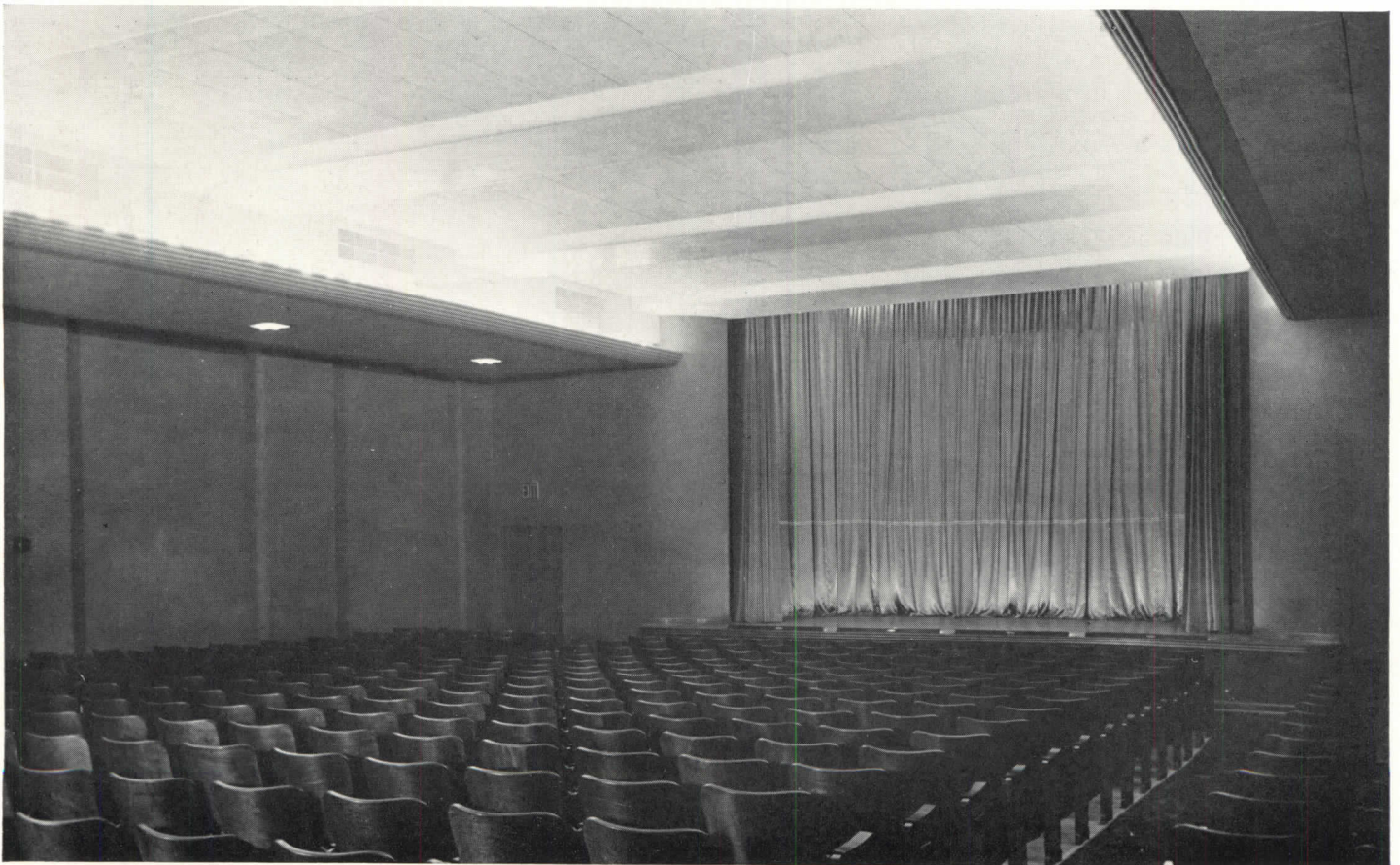

The auditorium is air-conditioned; Johnson Service controls. The ceiling has J-M acoustical treatment. Seating by Peabody.



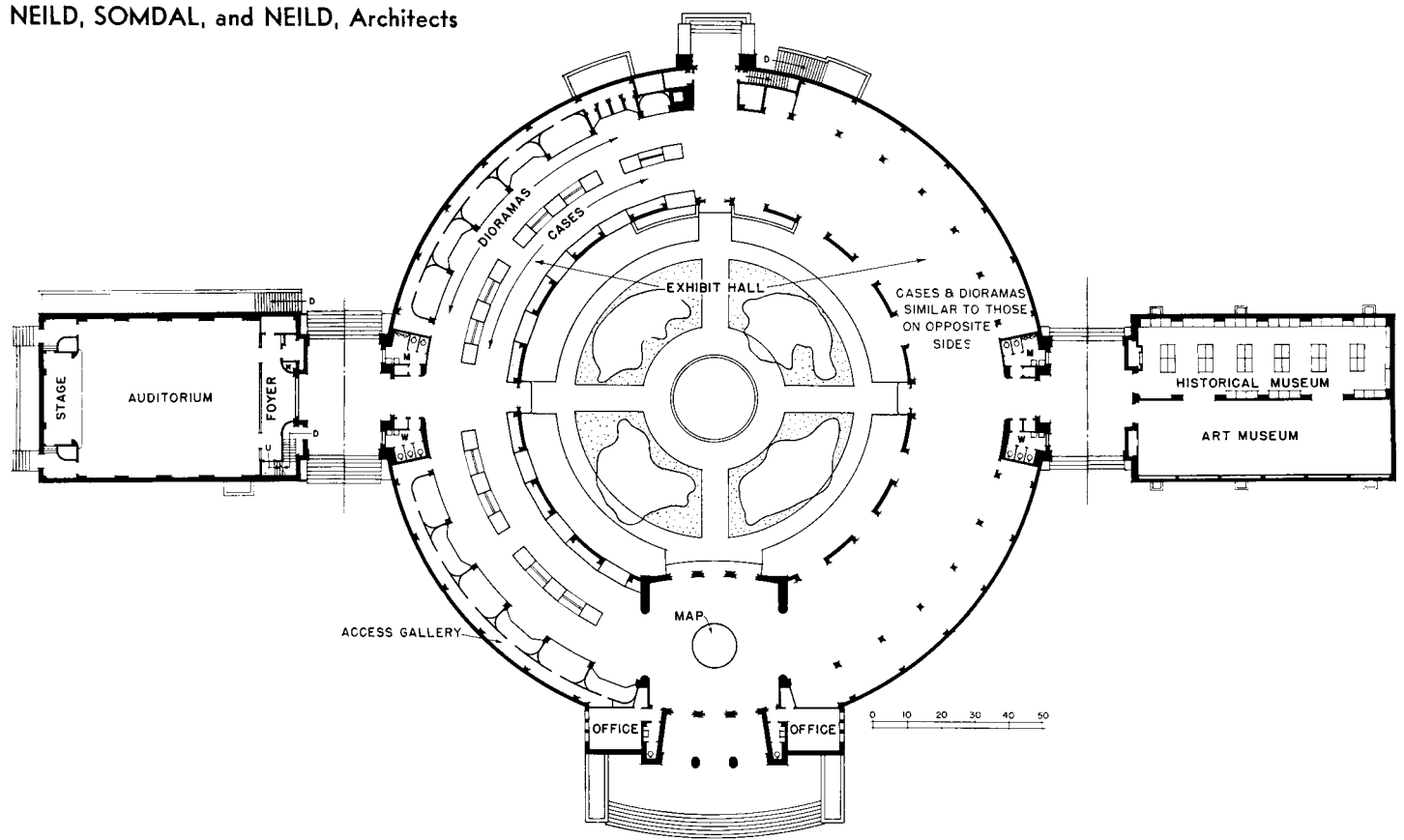

The museum is devoted half to history, half to art. Walls are surfaced with fabric. Floors are of asphalt tile by Moulding.



All photos by Roger Sturtevant

On the theory that growing plants need little architectural "support", this design provides a simple background.



## DISPLAY AND SALE OF NURSERY STOCK

in a metropolitan area constitute a merchandising problem quite different from that of the florist's cut flowers. In this store for the San Francisco nurserymen Martin & Overlach, Architect WILLIAM WURSTER has evolved an extraordinarily effective solution to a highly specialized (and sadly neglected) design problem.

TAKING ADVANTAGE of a large downtown plot, located on—but several feet below—one of the city's main arterials, the architect developed this store for the display and sale of hardy and exotic plants, pottery, and garden equipment.

Both the need for economy and the nature of the stock itself dictated simplicity in the building. Aside from providing work space for propagation, potting, packing, shipping, and receiving, etc., the main design problem was to provide an attractive and flexible display for a wide and constantly changing assortment of hardy, semihardy, and exotic plants. But to maintain the plants at maximum efficiency while on display, it was necessary to provide conditions of shade, semishade, open sun, and glass. The one over-all requirement for the plants was that they be protected from prevailing winds. Using these varied requirements as basic elements, Mr. Wurster has organized a design of extraordinary effectiveness as a selling tool, with the merchandise itself at the focal point.

Since the climate is mild, the majority of the selling area is open. The main salesroom and office along the street front is of wood, with exposed framing and T & G siding on the exterior. A wide use of glass on both walls (p. 46) makes this area in effect a part of the garden. Floors are brick, laid in sand; heating is with gas.

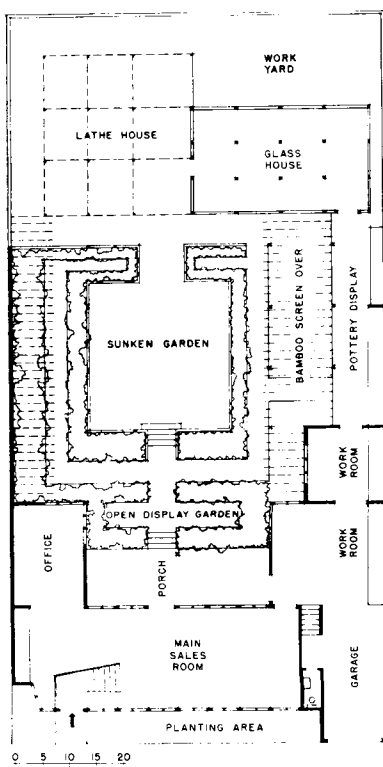

**DOWNTOWN NURSERY STORE**

W. W. WURSTER, Architect



Street front is of wood siding, painted olive grey and set back to provide planting space. Glazed wall permits full view of salesroom from street.



Main salesroom (center) is approximately 3 ft. below street level and 2 ft. above garden level (bottom), providing both planted and potted display.



by K.H. Case

## ROMANESQUE IN INSPIRATION

contemporary in concept, the new chapel of the Slovak Girls' Academy, Danville, Pa., is the work of HENRY D. DAGIT & SONS, Philadelphia architects for the Sisters of Sts. Cyril and Methodius.

ACCESSIBILITY OF the chapel being of prime importance to a religious community such as that of the Sisters of Sts. Cyril and Methodius, the location of the chapel was changed from that originally planned (right) to the main transverse axis of the existing Motherhouse. This not only eliminated "walks of great distance four or five times daily" for the sisters, but also resulted in important economies (in walks, cloisters, etc.). More important, perhaps, it enabled the architects to use the mass of the huge memorial tower as a pivot for design of the new addition.

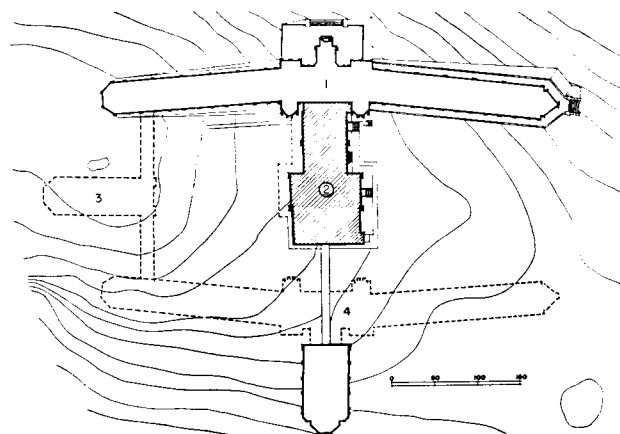
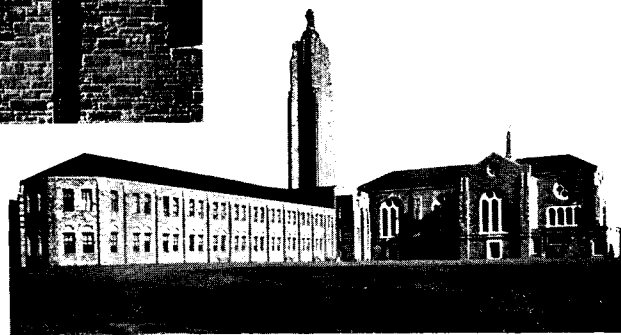

PLOT PLAN. 1. Original unit. 2. Location of new chapel. 3. Location of chapel in original design. 4. Proposed future extension.



Concentration—against plain backgrounds—of detail of great richness lends drama to the high altar and its baldachino.

# CHAPEL, SLOVAK ACADEMY

H. D. DAGIT & SONS, Architects

"THE FIRST REQUIREMENT", according to the architects, "was a seating capacity of about 600 and a large sanctuary. The clients also required a clear view of the altar and sanctuary from all points of the interior, which meant the elimination of all columns. To effect this, the buttress construction was pierced to form the side aisles in the nave. Also, to obtain the desired seating capacity, it was decided to design the chapel in cruciform plan and to span the transepts without columns".

Conformity with the style of the original building on one hand, and the clients' desire for long life and low maintenance on the other, led to a design notable for its simplification of detail and permanence of structure. Floors throughout are of reinforced concrete, finished in terrazzo in various marbles; walls are surfaced internally with travertine, externally with Foxcraft stone (to match the original building) and Indiana limestone trim. The roof is of black slate laid on 2-in. precast concrete slabs carried by steel trusses. The vaulted ceilings are of Guastavino acoustic tiling, buff with gold and varicolored trim. All metalwork is by Caldwell & Co.; all woodwork (including seating) by Hackner Co.



Sanctuary lamp is executed in polished aluminum and gold plate.

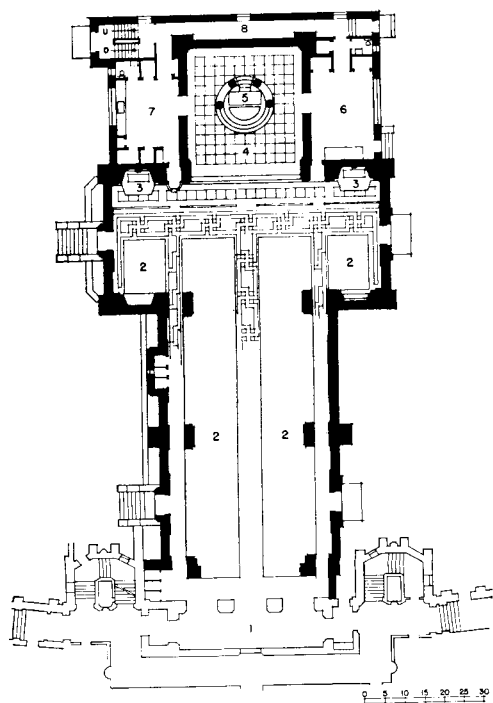

MAIN FLOOR. 1. Lobby of original building (now "porch" of chapel). 2. Seating in nave and transept. 3. Side altars. 4. Sanctuary. 5. High altar. 6. Priests' sacristy. 7. Work sacristy. 8. Passage.

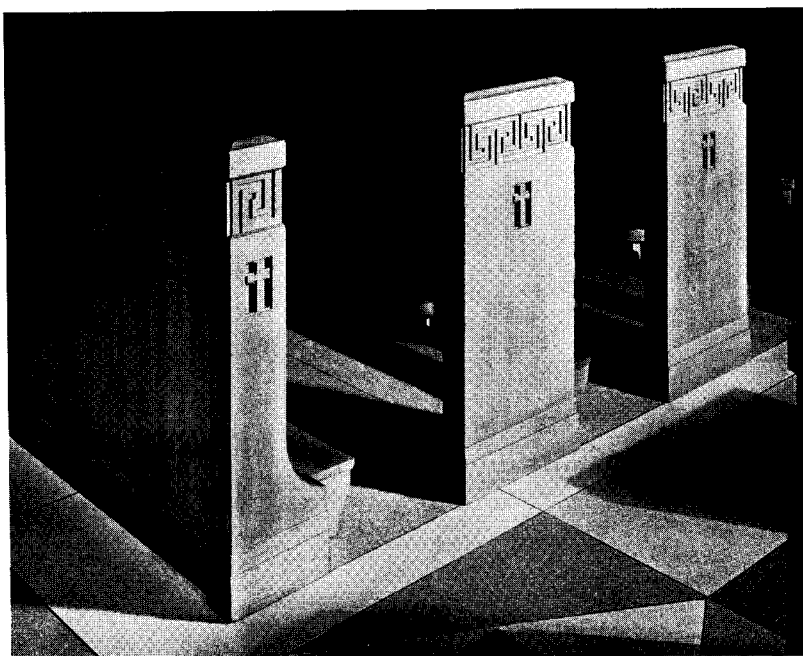

Pews reflect attention to and simplification of detail and construction.

## CHAPEL, SLOVAK ACADEMY

H. D. DAGIT & SONS, Architects



The nave by night (above) and day (left).

The chapel employs a combination of direct and indirect lighting. Pittsburgh Permoflectors, placed in the vaulted ceiling, are wired on three circuits, using lamps of three different intensities (200-, 300- and 500-watts) giving flexibility in the amount of light required for early morning services or at night. Reflectors directed at the ceiling are also installed below the sill line of the windows. Cleaning and lamp replacements are easily and safely accomplished from the attic walkway, since reflectors are so designed that the entire unit lifts out from above. Sill reflectors are also accessible from the floor.



All photos by Cedric Wright



## DRESS SHOP EXPLOITS SMALL FRONTAGE

To make the most of a very small space was the problem faced by **JOHN EKIN DINWIDDIE, Architect**, in this specialty shop in Berkeley, Calif.

THE SHOP, one of a row of commercial buildings, gains immediate distinction by its treatment of the street facade: the splayed walls not only attract interest but give greater display area. Design details are of the simplest; for instance, plate glass for the display cases is set flush at ceiling and wall. Spot lights, recessed in the ceilings of the display windows, dramatize the shop's wares. The exterior color scheme—chocolate brown and golden gray—is neutral enough to serve as background for displaying garments of any color. The plant bed in the lobby is continued into the large display window.

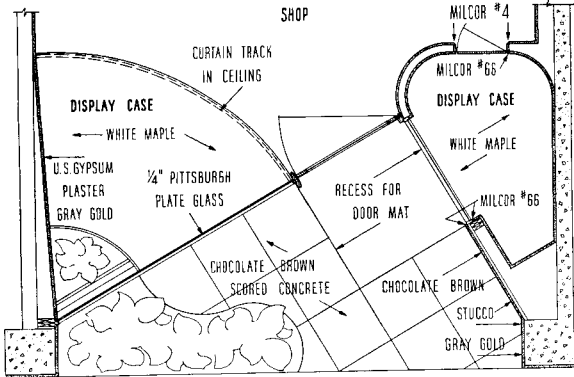



Salesroom walls are oyster white, ceiling gray-blue; floor, beige Broadweave.



Photos by Cedric Wright

Recessed display panel is chocolate brown; furniture is by Alvar Aalto.

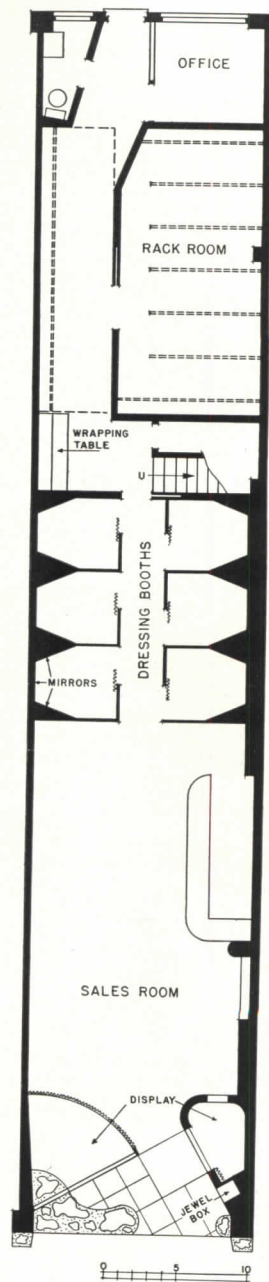

COLOR PLAYS an important part in the interior. The wall and ceiling at the rear of the store are coral, with the plywood partition which marks the entrance to dressing booths painted gray-blue. Walls of dressing booths are white. On the mezzanine floor above the rack room is an open work area. Metal figure, display racks, and lighting fixtures are by Karl von Hocht. Recessed lights, General Electric spots and floods. Crane Co. plumbing fixtures. Heating, Aladdin Heating Co. warm-air, gas-fired furnace.

# NEW STATION FOR MILK IN TRANSIT

This milk-receiving station at Enfield, N. H., gave C. W. MURPHY, staff architect for H. P. Hood & Sons, an opportunity to demonstrate the importance of designing a new type of building that would "keep pace" with the advanced modern equipment now demanded for the handling of milk. Introduction by the company of a new premium-quality milk meant up-to-date facilities for precise control of the product from time of arrival at the station to actual shipping.

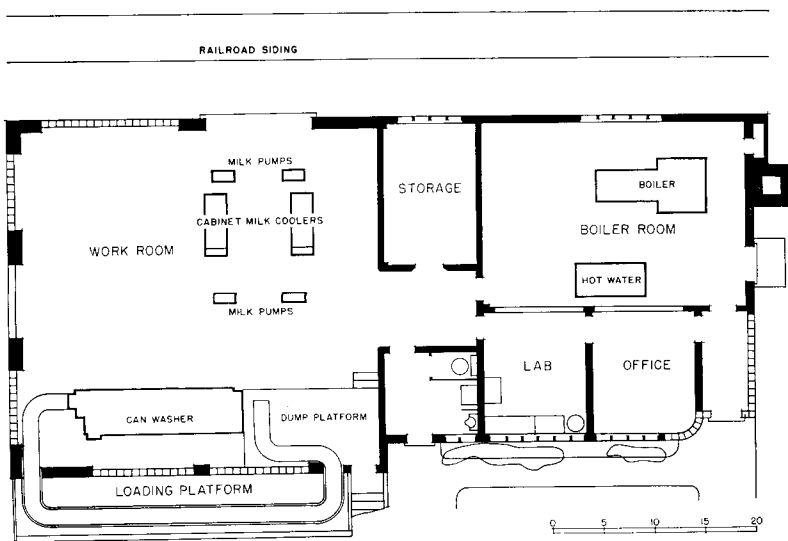
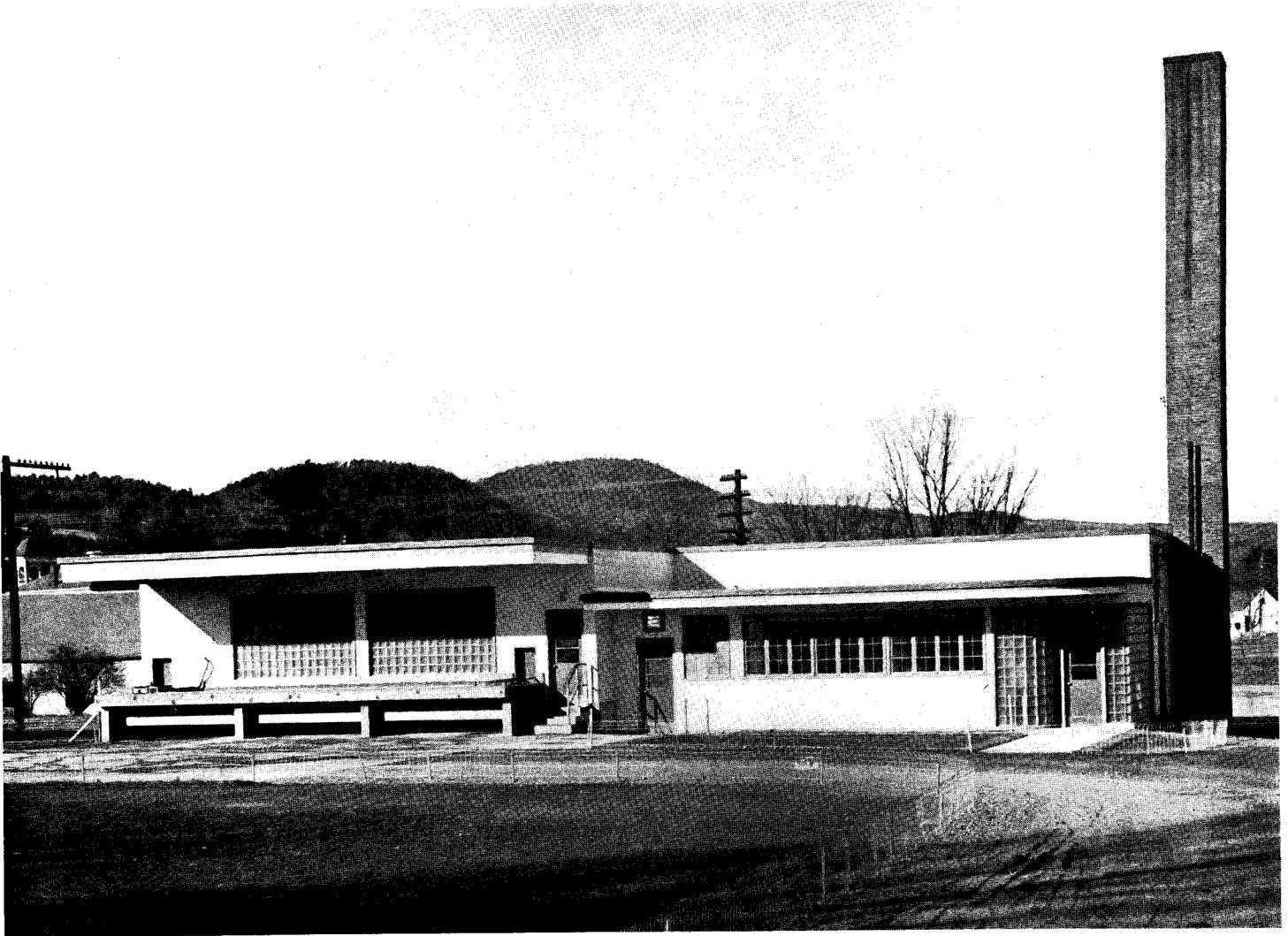

THE BUILDING contains two distinct parts: the can-washing, loading, and work area; and the office, laboratory, and utility rooms. At either side of the large glass-block panels shown in the photograph above are small steel doors,—entrance and exit of a conveyor system which is part of the farm-to-market process outlined on the next page.

Construction of the building is of frame, with wool-type insulation. Exterior finish is of Carey Colonial asbestos siding, interior walls of Weldwood waterproof plywood above a dado of vitreous tile. The floors are Hanley quarry tile, laid on a concrete slab. Ceilings are surfaced with Homasote, and the roof is Carey built-up roofing over wood planking. Except for the panels of glass block and one or two fixed sash, all windows are Anderson wood casements. For ventilation, a Swartwout Rotary Airjector is installed in the roof above the can-washing equipment.

## MILK TRANSFER STATION

C. W. MURPHY, Architect

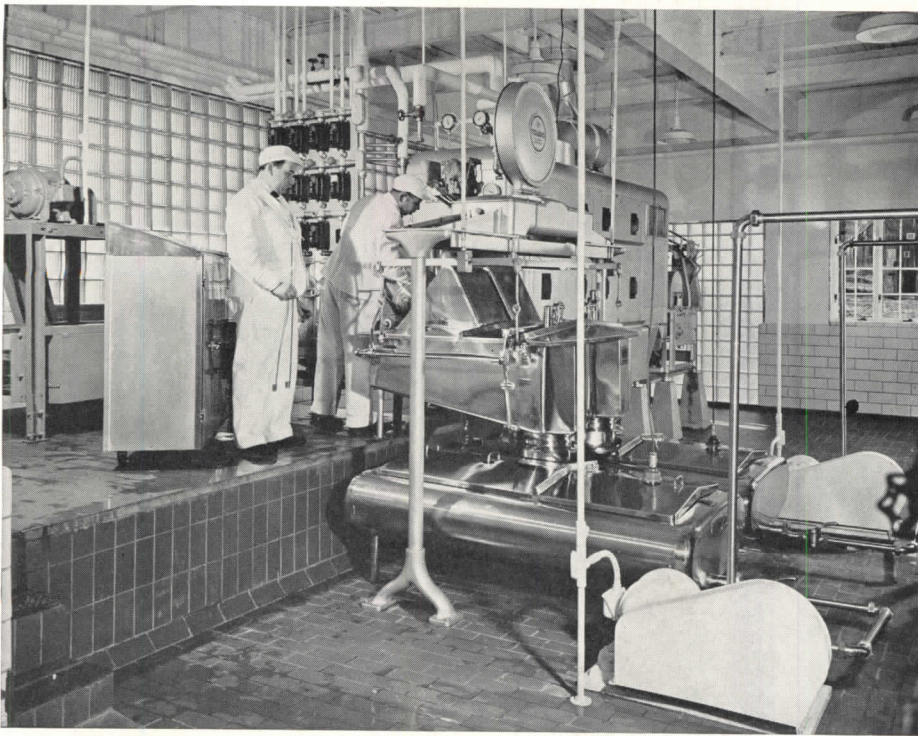

1. On this raised platform, the milk cans enter, are emptied into scales (as shown), washed, sterilized, and returned outside, all within five minutes' time.

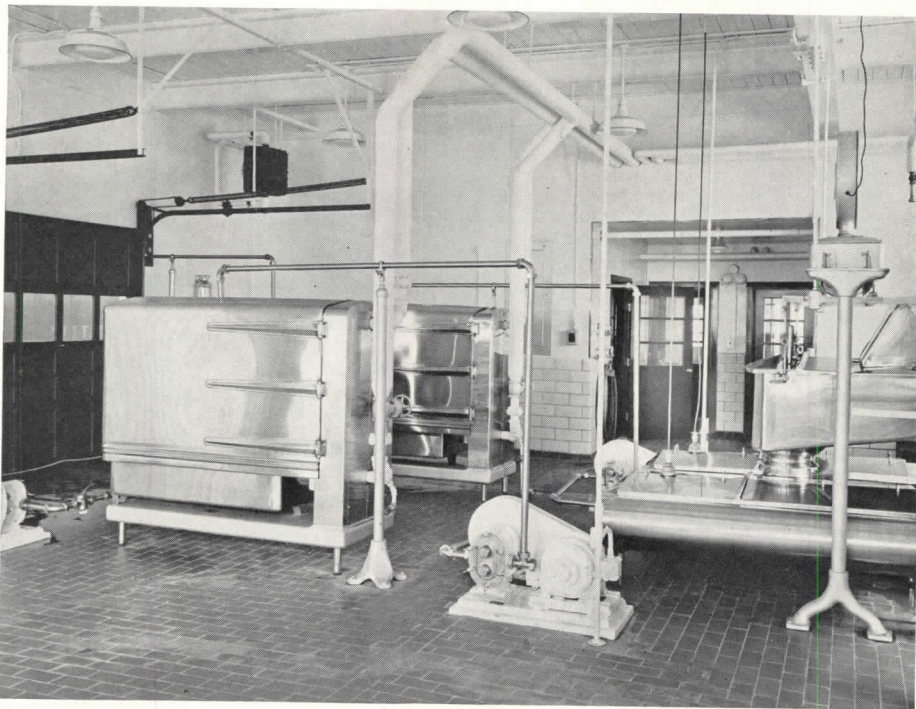

2. The milk is first weighed (at right), then pumped through coolers (center, left), and pumped again through the doors at left into a tank car on the siding.

THE DIAGRAM at right shows clearly how efficiently the building functions. The flow pattern resembles that of a manufacturing assembly-line, with each piece of equipment located in direct lanes of progress. The by-pass, shown by a broken line, indicates how the return of sterilized cans to the waiting farm trucks is accomplished without interfering with the milk-loading process. Construction cost of the building itself came to \$10,000; its equipment cost \$30,000.

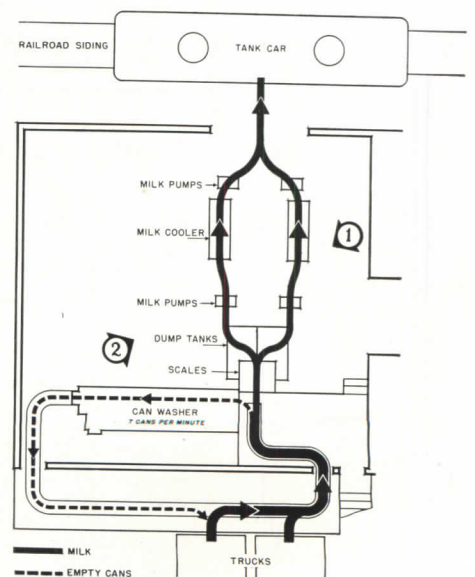

# NEW HOUSES AND NEW HOUSE UNITS

*Harold A. Willoughby & Assoc. photo*



**HOUSES WITH FROM TWO TO FOUR BEDROOMS**



Photos by Harold A. Willoughby & Associates

## HOUSE WITH COMPACT, MULTI-LEVEL PLAN

This transitional-style house at Winchester, Mass., was designed by Architect DAVID J. ABRAHAMS for Prof. and Mrs. Robert Frazier. Professor Frazier is with M. I. T.'s Department of Electrical Engineering, and the high efficiency of the house, both in plan and advanced equipment, may be attributed to unusually close cooperation between client and architect. Noteworthy, too, are the compact plan and the adaptation of the design to a varileveled site.

WITHIN THE confines of a simple rectangle, Mr. Abrahams has contrived a surprisingly open plan scheme. Notice the efficient use made of the different levels imposed by the site. Total cost, including architect's fee and landscaping, was \$16,000.

Construction is of frame, with Celotex Vaporseal sheathing, surfaced with white-painted boards and siding. Insulation: Alfol. Roofing: Bolta asphalt-rubber shingles. Windows: Hastings, double hung and double glazed.

Inside the house, walls and ceilings of main living rooms are surfaced with Chase material— $\frac{1}{8}$ -inch-thick flexible covering now being developed by Bird & Sons—applied with special paste to a Masonite backing. Air-conditioning: Kelvinator, Minneapolis-Honeywell controls. Frigidaire range; Kelvinator refrigerator; Thermo-watt water heater.







# HOUSE

## TOPS A HILLSIDE WITH A VIEW

Architect VAN EVERA BAILEY states the problem involved in planning this distinctive modern home for Mr. and Mrs. Edwin Badgley in Portland, Oreg.: "to fit the house to a site with a drop in level of 14 ft. across the house, to place the garage so that it would be easily accessible to the road at the top of the site, and to take advantage of a wide-spread mountain view toward the east, away from the roadway above."

UPPER FLOOR

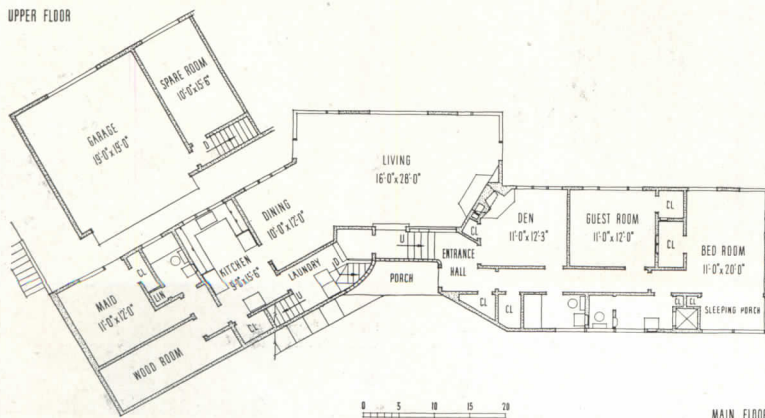

MAIN FLOOR

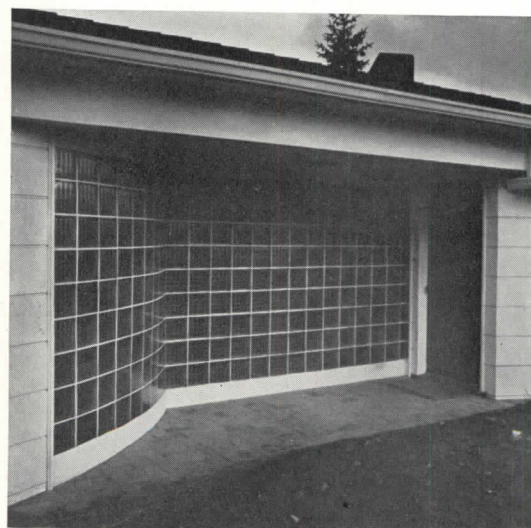

Insulux glass-block wall on the entrance porch.



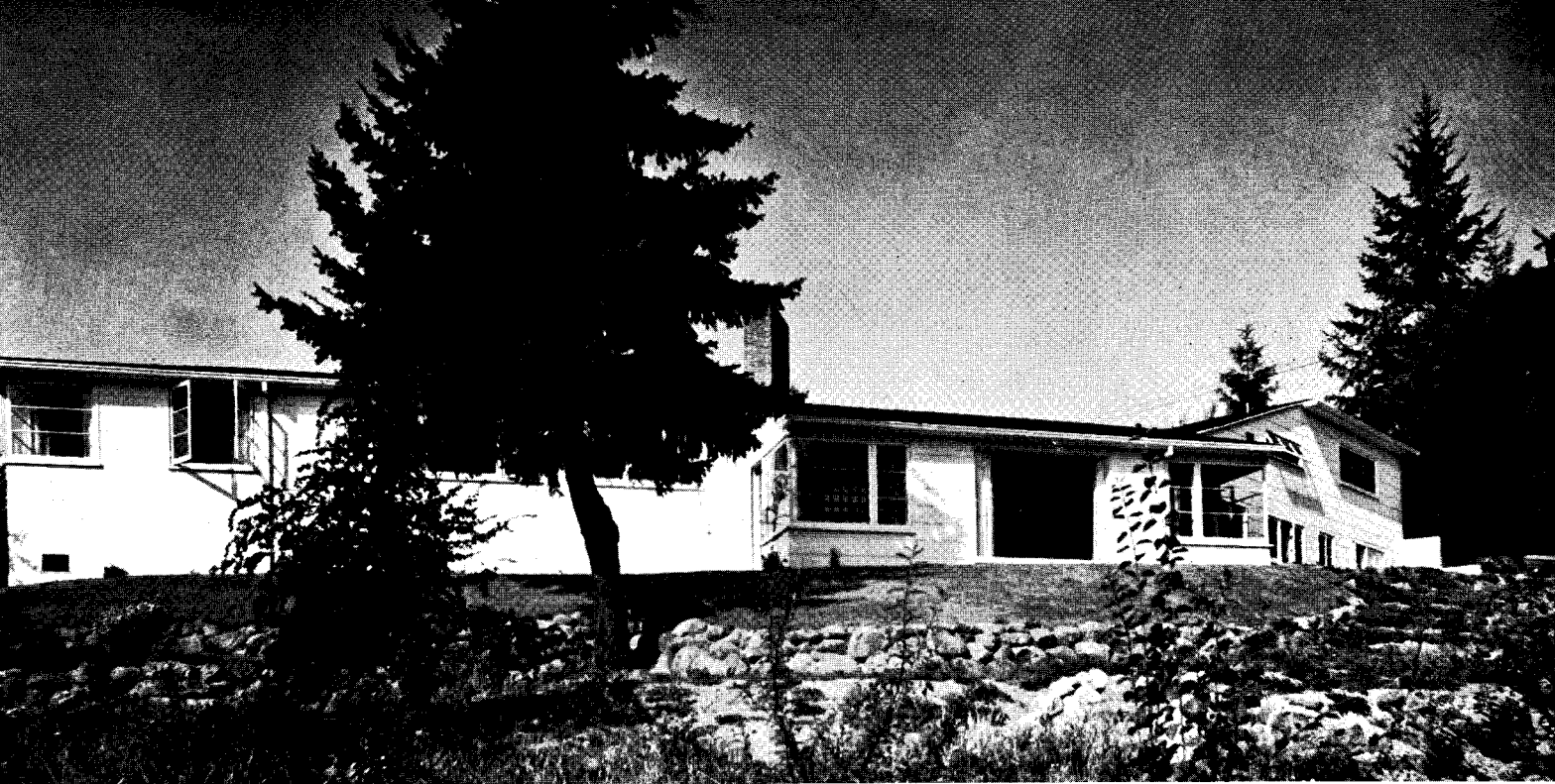

PLANNED FOR informal living in a country-suburban location, this spread-out house is arresting both as a straightforward solution to a difficult site problem and as a design with a pleasingly domestic quality achieved with simple modern elements. The unbroken sweep of the roof line as it parallels the slope throughout is a refreshing handling of the sloping-site problem, and it gives the completed house an unusually close relation to the ground on which it is built. This honest respect for site produces within the house numerous different floor levels which are variously used to separate the different portions of the house and to give informal room arrangement—a few steps up, here; a few steps down, there. Facing the most favored view is the broad projecting living room, with huge window areas and access to the terrace on this side.

Of standard frame construction, the house is surfaced with broad, white-painted siding. The cedar shingle roof is left natural. Total cost of the house, exclusive of architect's fee was \$10,500.



Photos by Roger Sturtevant

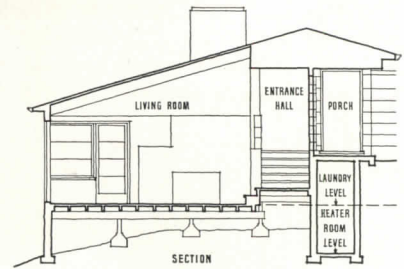

The photographs and section above and at right clearly show the different levels caused by the 14-ft. change in site level. From the entrance and bedroom hall (top right, living-room photo), stairs come down to a platform. At this landing, two steps on the right reach the living-room floor level; straight ahead are the door and steps down into the laundry room, shown at right. In back of the set tubs may be seen the doorway to the still lower level, beneath the porch, where the oil-burning Vortex Comfortair furnace is located.

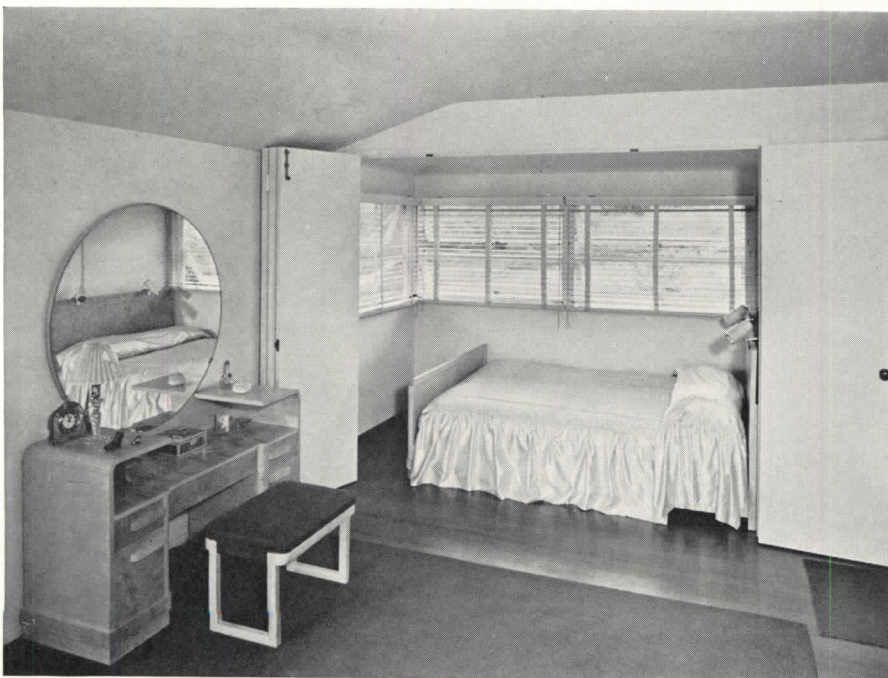
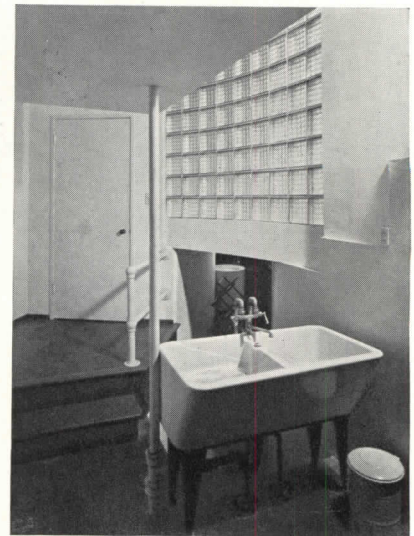

Photos by Roger Sturtevant

Off the master bedroom is this ingeniously devised sleeping-porch unit. With folding doors closed, it is wholly separated from the room proper.

MATERIALS and equipment include: Brownskin building paper, USG plaster, Kohler plumbing fixtures, Masonite-block floors (used throughout house, except in baths), Holmes overhead garage door.

# HOUSE THAT FITS SITE AND A BUDGET

In Architect JOHN EKIN DINWIDDIE's own words, the basic problem in the design of this hillside home for Mr. and Mrs. Thomas Anderson, Jr. at El Cerito, Calif., was "the usual one of getting the most from a limited budget". Results: (1) The \$7,000 budget was approximately met. (2) The owners' comment after completion: "It is a small house, but we have room to move around in where we need it. We live in it so easily."

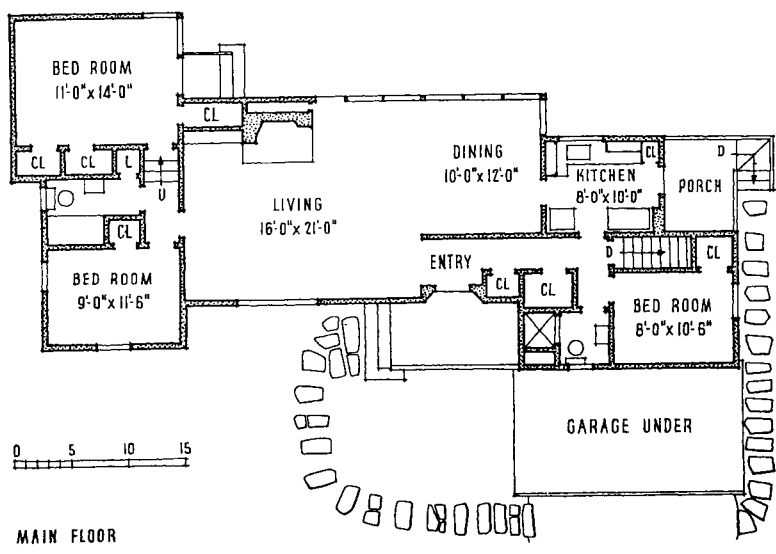

To ACHIEVE AN AIR of spaciousness in so small a home, Mr. Dinwiddie allotted the major area to a combination living-dining room, keeping the more private rooms to workable minimums. A sharp drop at one corner of the lot was turned to good advantage. By locating the two-car garage, the heating plant, and a laundry-dark room in this depression, excavating was practically eliminated, and the scheme gives the house exterior a felicitous relation to its sloping site. The bedroom above the garage, at present serving the dual purpose of study and sewing room, is later to become a maid's room. Construction is of frame, with concrete foundations and walls surfaced in gray stucco, white wood trim. The cedar shingle roof, laid with every sixth course doubled, is a neutral olive green.

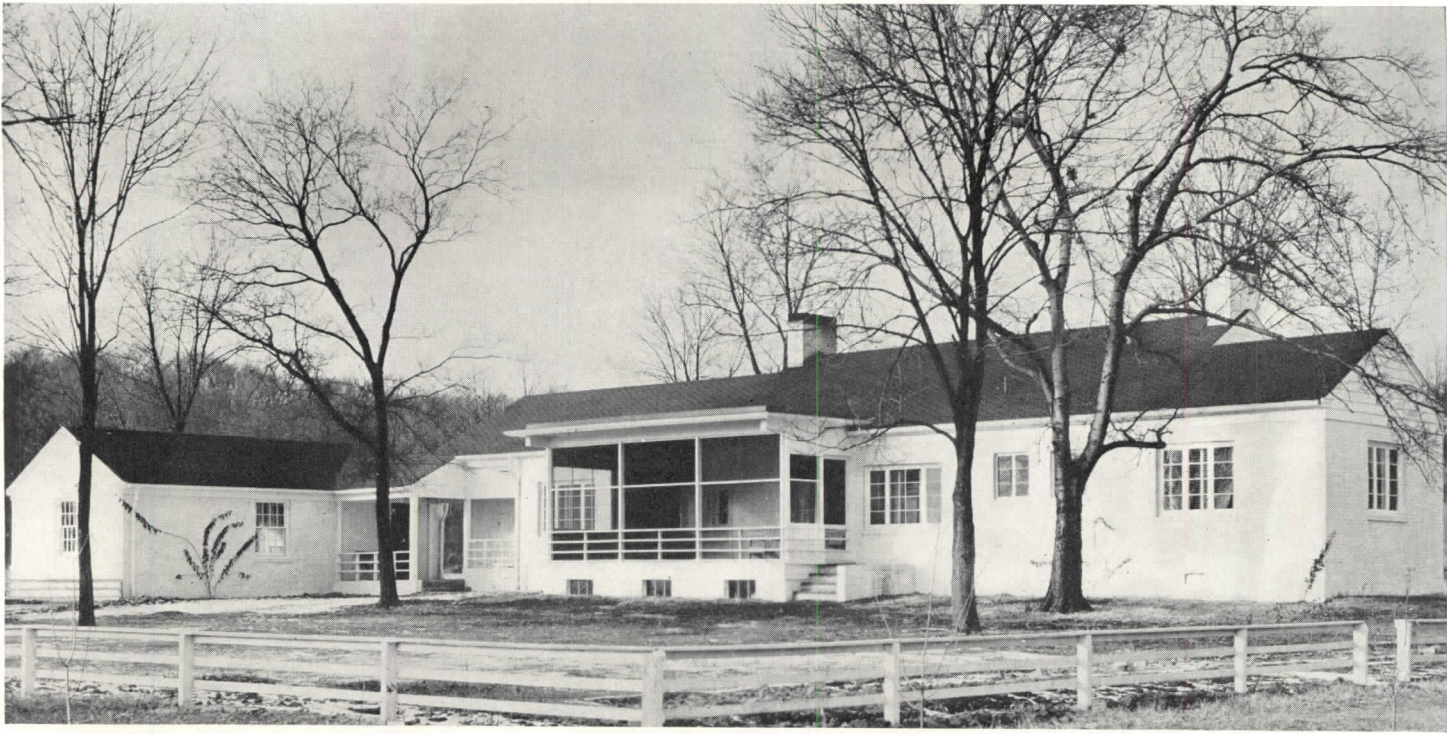

## HOUSE

### A DESIGNER'S OWN HOME

"We live very informally, and no wasteful halls were required," says HENRY H. MILLER in commenting on his own suburban home near Nashville, Tenn. "The open plan worked out naturally to encompass views on both sides of the property." As a result, the fenestration is noteworthy, including not only casement and sliding sash, but one that lifts up into the roof structure.

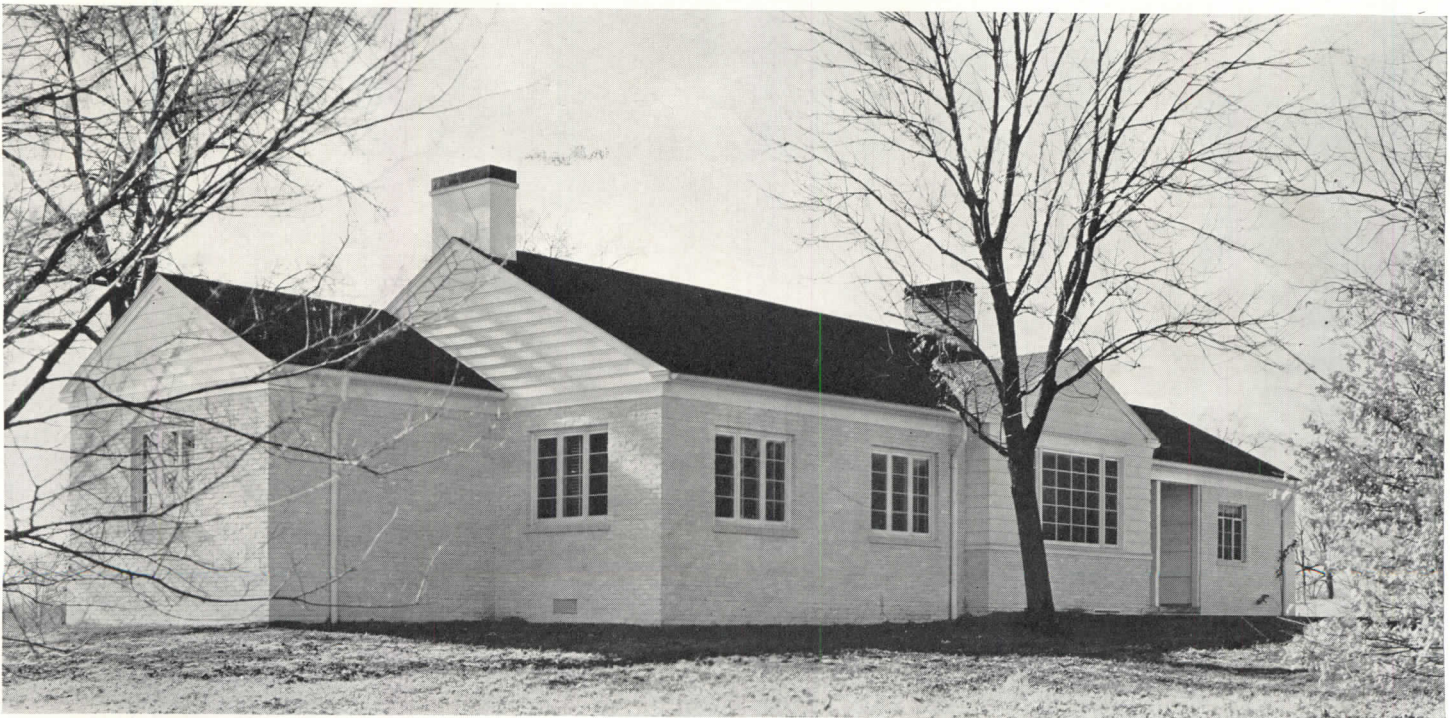
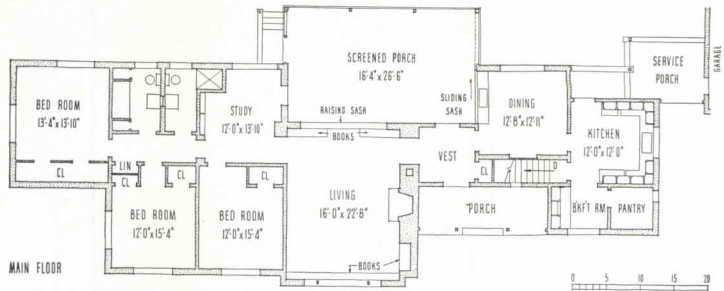

Photos by Wiles

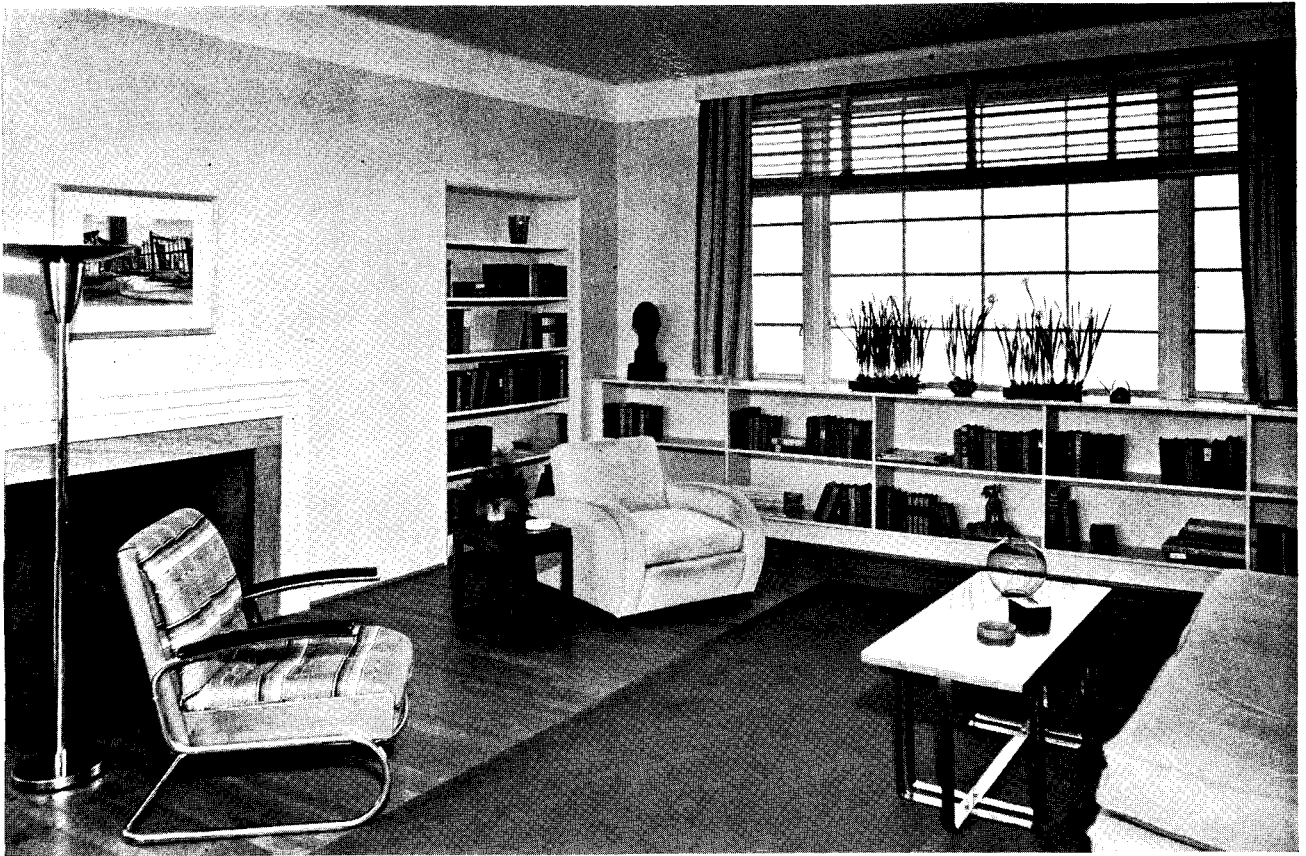

Above: end of the living room toward the front of the house. Right: the raise-up window at the porch end of the room. Below: the compact dining room.

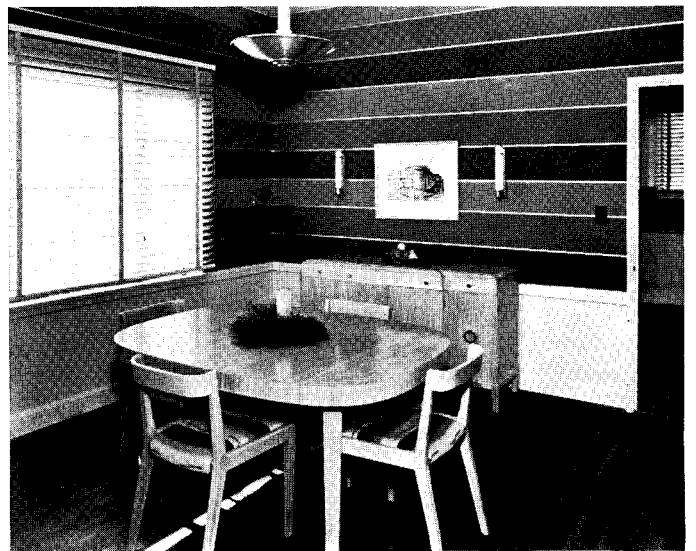

THE BASIC SCHEME of the house, reading the plan from left to right, is sleeping zone, living zone, and service zone. The central living room commands distant outlooks at either end. On the side toward the summer living porch, the big window lifts up out of sight under the roof and is left raised for the greater part of the summer season. The screened porch keeps even a driving rain from entering. Between the dining room and the porch is a full-length sliding sash. Opened, this becomes a windshield across the end of the porch at this point.

The house is stud framed, finished in both brick veneer and siding, and cost approximately 32 cents a cu. ft. to build. The walls are completely insulated with Tensulite rock wool. Neponset asphalt shingles, laid 4 in. to the weather, cover the roof. Casements in main rooms are Pella, with Rolcreens; in utility rooms, Truscon casements. Doors: Johns-Manville flush, hollow core. Crane bathroom fixtures. G-E range; Frigidaire refrigerator; Hotpoint water heater. Hot-air circulating system serviced by Peerless Steel furnace, with Econocoal bin-feed stoker. Ventura attic fan. Electrical fixtures: Lightolier and Westinghouse Luminaire.



*Photos by Julius Shulman*



Top: the outdoor living deck.  
At right, in order: general  
view of the front; the south-  
ern end; the rear of the house.

# HOUSE PLANNED FOR ONE OCCUPANT

In planning this compact Los Angeles home for Miss Urcel Daniel, Designer GREGORY AIN found fresh solutions to two typical problems: (1) that of a steep site; (2) the problem of providing an easily cared-for home for a single person who goes to work each day. At the rear—to the east—is a far-flung view, which the designer capitalized with enormous window areas and an outdoor living deck. Total construction cost of this small home was but \$4,950.

MISS DANIEL, the owner, holds the position of secretary to an executive, and there is little time left for housekeeping. To help keep this to a minimum, Mr. Ain devised a very compact work room, combining kitchen and laundry in a single unit. Much of the furniture in the house is built in place, further reducing housekeeping cares. The living room, dinette, deck, and entry porch are treated as a single large space, their unity being achieved by means of a symmetrically hipped ceiling which covers them all. Above the living deck and at the entry, the ceiling is left off, the framing members forming pergola beams. Mr. Ain points out that the sloping ceilings were first suggested by a tract restriction which made a pitched roof mandatory.

The designer has incorporated a clerestory for lighting the interior hallway and bringing late afternoon sun into a kitchen that faces east. Recessed into the roof (as shown in the detail) is a triangular trough, the back side and ends of which are glazed, lighting the center of the house.

Both interior and exterior color schemes are the same. Stucco outside and plaster inside are light cream. Structural wood posts, door and window trim are olive green. The Pabco mineral roofing is white.

In materials and equipment, the little house is thoroughly up-to-date. Alfol insulation is used in the roof; ceilings are of Insulite; pine wainscoting from U. S. Plywood; L-O-F glass. Williams Warmolator unit heaters; Standard Sanitary plumbing fixtures. Armstrong linoleum floors in kitchen and bath; drainboards of Trent rubber. Schlage hardware; Whitco outswinging casement hardware. Trojan water heater.

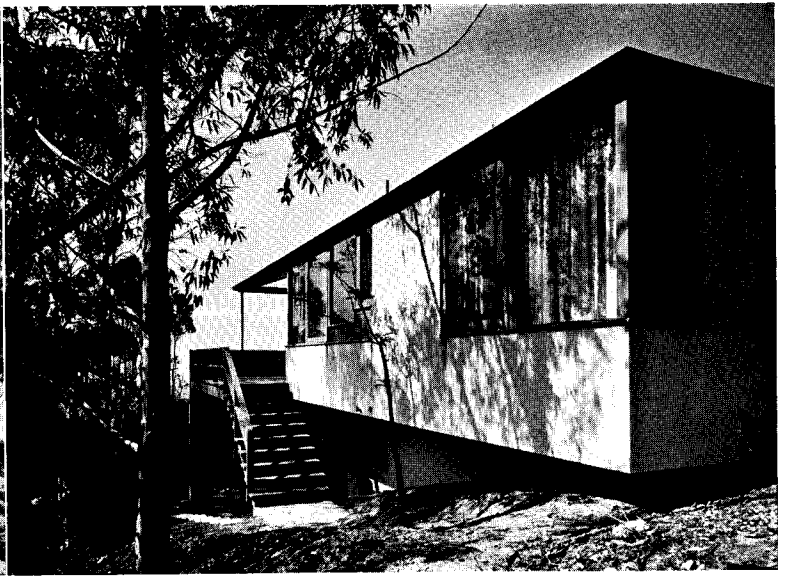
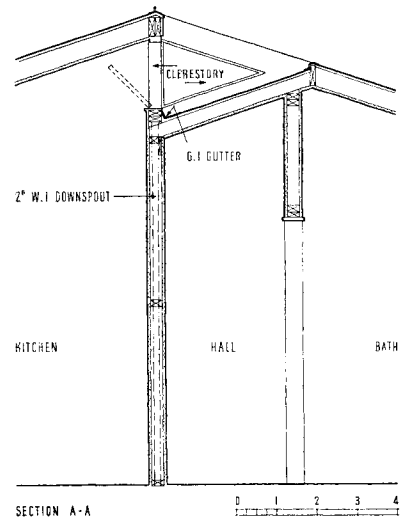
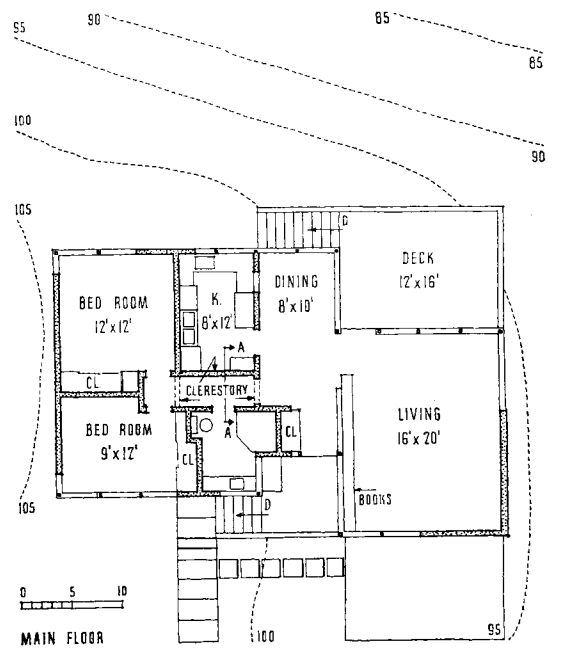

Photos by Roger Sturtevant

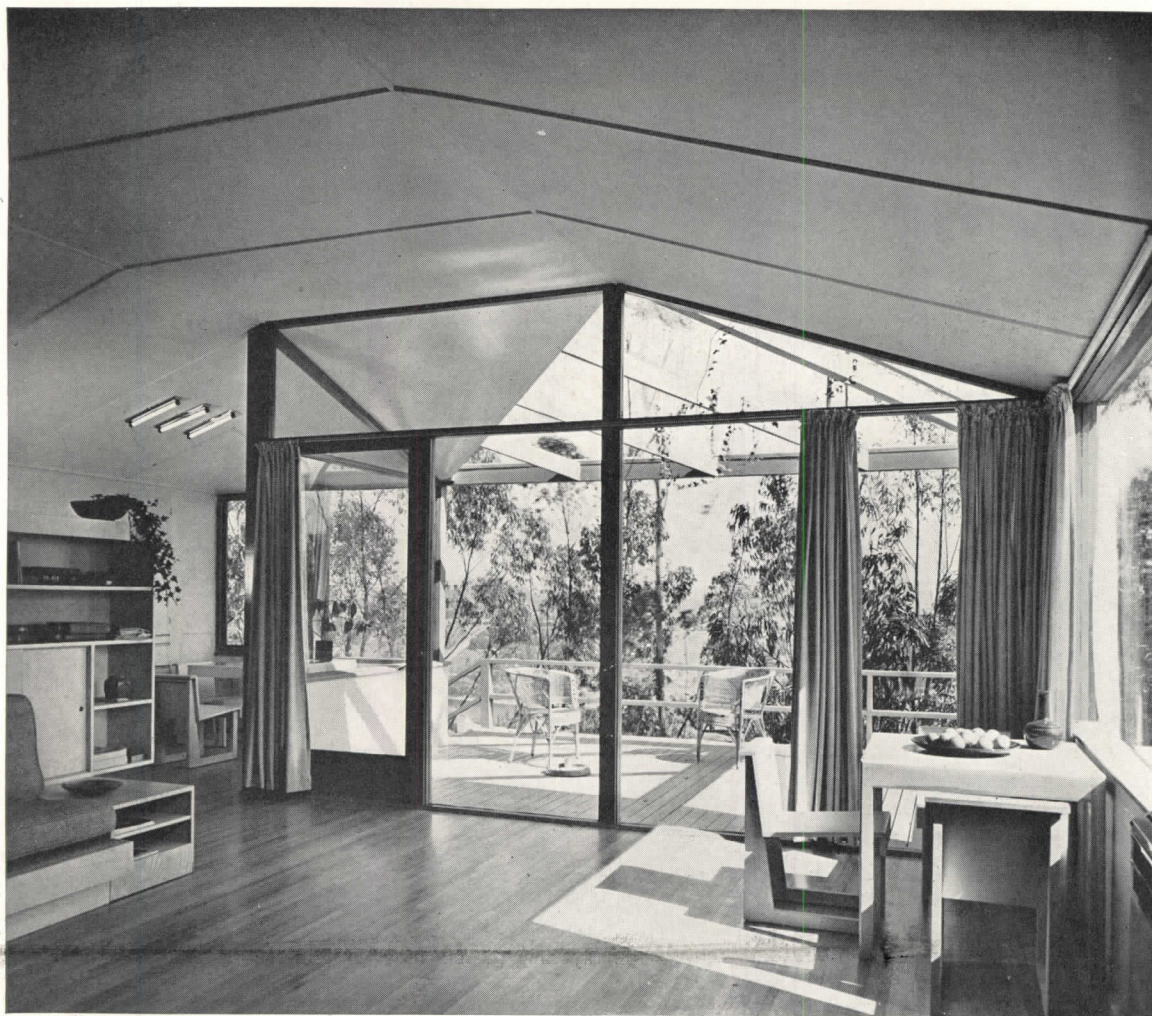

Living-deck end of living room. Huge windows and open-frame porch roof bring outdoor living indoors.



The built-in bookcase in the living room, 5 ft. 4 in. high, screens the entry. Under a wire-glass top shelf are concealed lights, providing indirect illumination.



# HOUSE

## AMPLE ACCOMMODATIONS, LOW COST

Architect GERHARDT KRAMER designed this New Orleans home for the Ernest Noyes family. It is a striking example of one architect's realistic approach to a difficult—and increasingly familiar—planning problem: to design a good-sized house that falls within a modest-sized budget. How successful Mr. Kramer's solution was is apparent in the fact that the total cost of this four-bedroom, two-bathroom house (exclusive of the architect's fee) came to only \$6,050.

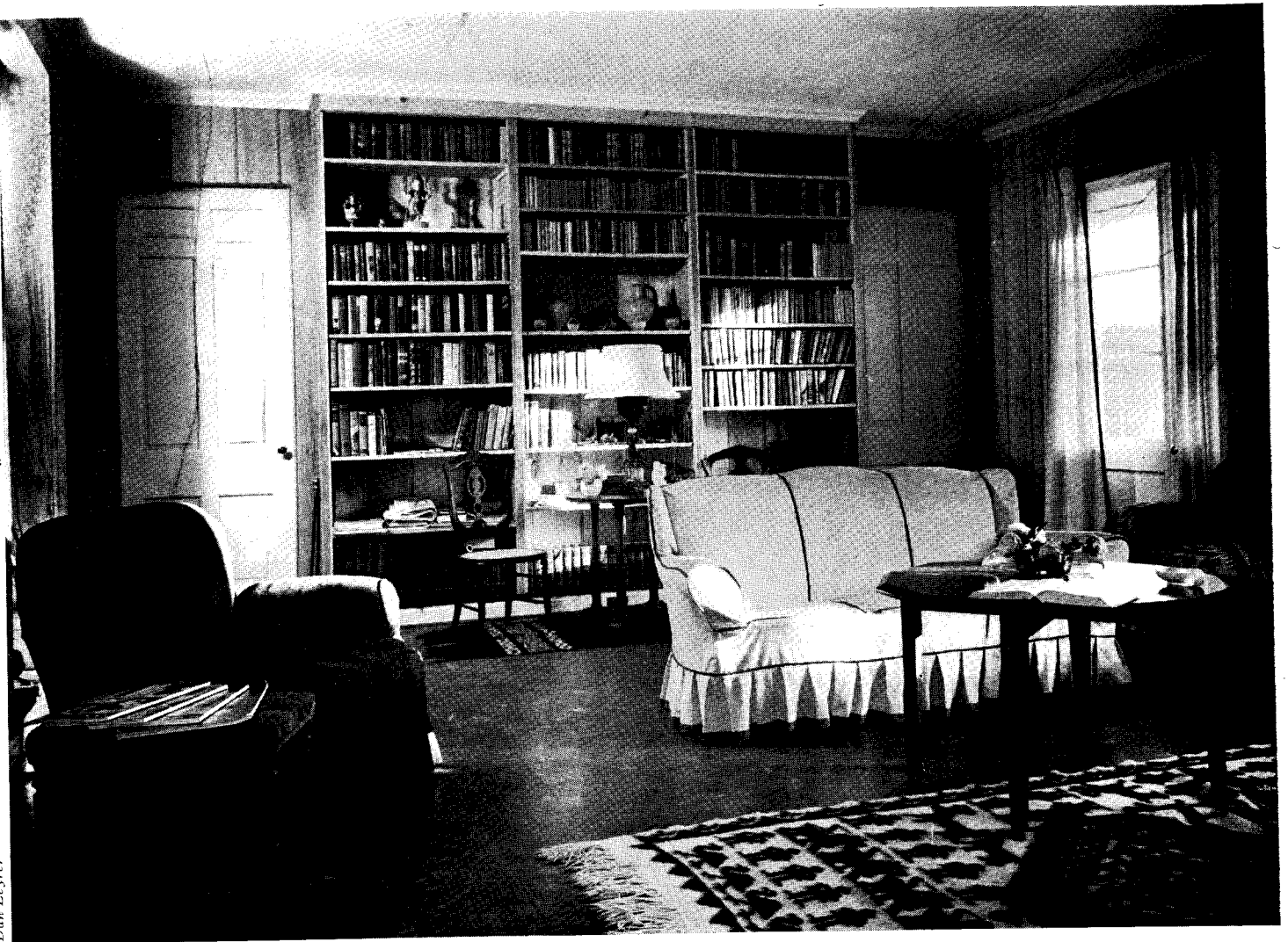

Ceiling-height bookcases at one end of the living room, which is finished in a beaded board of natural cypress.

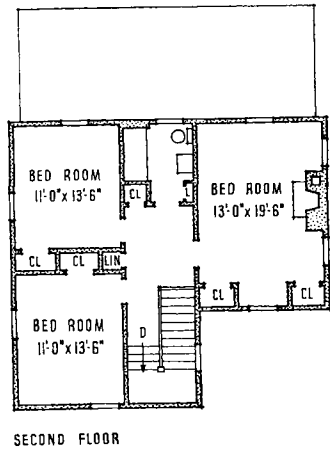
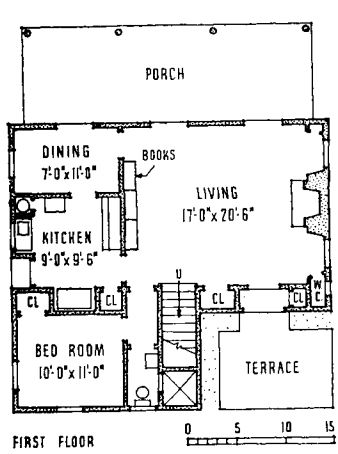

TO CONTRIVE A HOUSE of this size within the budget limitations, Mr. Kramer tells us that his clients preferred to subordinate other things "for the benefit of acquiring a gracious and comfortable interior—of which point, I heartily approved." In essence, the house resolves itself into a large and dignified general living room around which are grouped small-size—but adequate—secondary rooms. The plan reflects the mild New Orleans climate and an informal way of life. The front door opens directly into the large room, and glazed double doors in both this and the dining porch lead out onto the wide rear living porch overlooking the garden.



Photos by Dan Leyrer

The fireplace and stair walls of the living room; stairs have Curtis handrails.

FOUNDATION WALLS consist of brick on continuous reinforced concrete footings. Construction is of frame, with Weatherbest shingles over storm sheathing. All first-floor rooms (except bath) have cypress board walls and Armstrong Accotile floors laid on a concrete mat. Lath and plaster are used on the second floor, with pine board floors. Corbin hardware. Standard Sanitary plumbing fixtures.



# UNITS VIEW WINDOWS



*P. Douglas Anderson*

## 1. J. R. MILLER and T. L. PFLUEGER Architects

TO TAKE ADVANTAGE of the natural beauty of the immediate surroundings and of a view toward a lake and the ocean beyond, two large glazed panels were used; these were located in the room at points from which the view could best be seen. Since the glazed panels are actually floor-length French doors, the two terraces are readily accessible and are essentially an extension of the living room.

### Materials and equipment

Sash: aluminum, The Kawneer Co. Hardware: P. and F. Corbin. Walls: canvassed plaster.

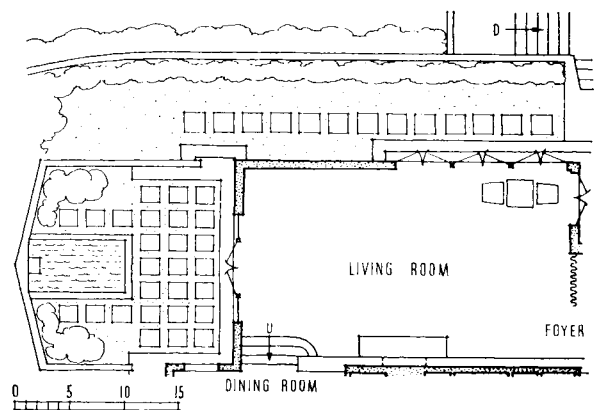

# UNITS VIEW WINDOWS



Roger Sturtevant

## 2. HERVEY PARKE CLARK

### Architect

THE LIVING ROOM of this penthouse apartment overlooks San Francisco Bay and the hills beyond; to exploit this dramatic view, the architect designed a window unit which, by its simplicity of detail, acts as a frame. The side panels of the window are hinged and open on to a balcony; the central panel remains fixed. The curtains at either side are loosely woven of thread and cellophane; since they are translucent, they soften but do not cut off the view.

#### Materials and equipment

Sash: steel, Michel and Pfeffer Iron Works, Inc. Weatherstripping: Parker Weatherstrips Co.

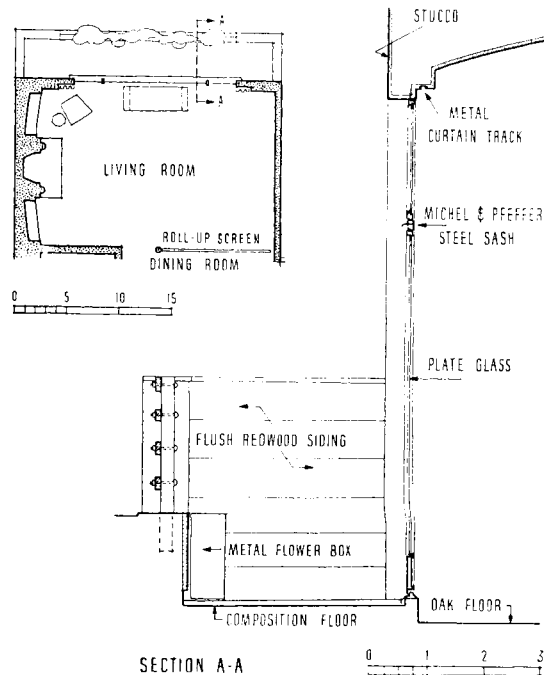

SECTION A-A

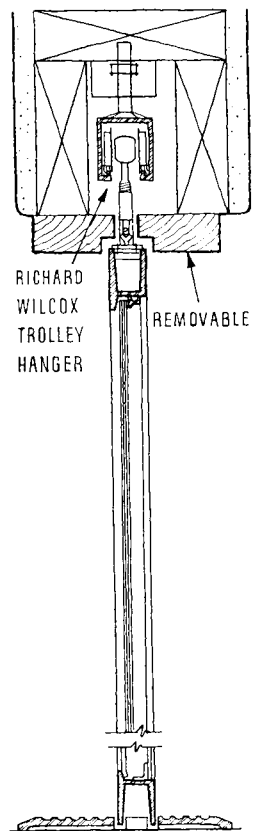

SECTION A-A

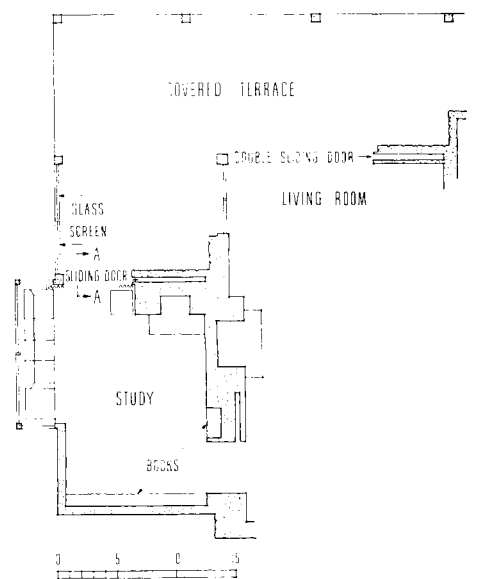
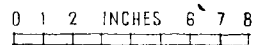

### 3. J. R. DAVIDSON

#### Designer

BOTH STUDY AND living room open on to a covered terrace which overlooks a hill and an intervening valley. In these two rooms as much glass has been used as possible so as to make the view accessible from all points. Shown above is the view from the far end of the study. Doors leading to the terrace are of steel-framed plate glass, and slide into wall. At the left of the terrace, and adjacent to the study entrance, is a plate-glass windbreak.

#### Materials and equipment

Glazing: Libbey-Owens-Ford. Doors and windows: frame, Truscon Steel Co. Terrace floor: brick, laid on cement slab.

# UNITS VIEW WINDOWS



Fred A. Dapprich

## 4. GREGORY AIN

### Designer

A PANORAMIC VIEW is not the only reason for designing a special window unit; in the living room, pictured above, the outlook is directly into the treetops. The end wall of the room is almost entirely glass, and the trees provide privacy as well as an effective backdrop. The walls of this house are of prefabricated plywood panels, so detailed that each panel may be used, without special connections, to form a concave or convex corner, door or window jamb, as well as a straight wall with the adjacent panels. The full-height windows shown here are achieved simply by the omission of wall panels; posts, 4 ft. on center, are substituted.

### Materials and equipment

Walls: 1/4-in. Weldwood, U. S. Plywood Corp., painted light cream. Paint: three coats, Sherwin Williams Co. Cabinets: 3/4-in. Douglas Fir plywood, 5-ply natural finish. Draperies: Osnaberg cloth, natural light tan, Bemis Bros. Bag Co.

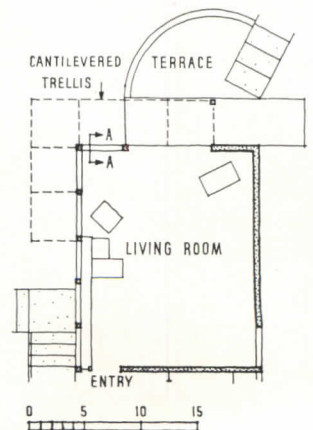
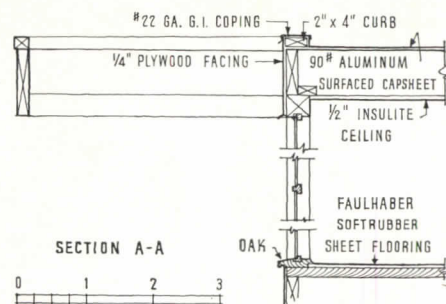

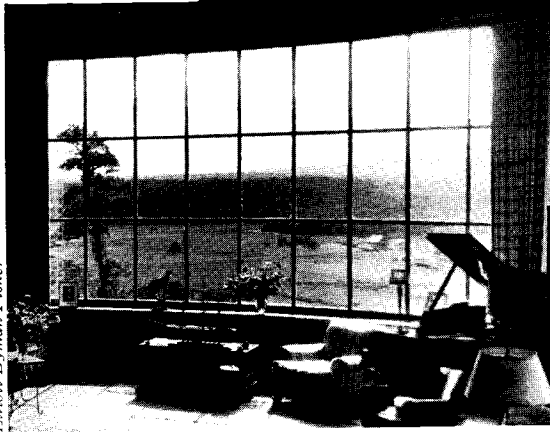

Elliott Lyman Fisher

## 5. HENRY IRVIN GAINES

Architect

TO TAKE FULL advantage of a superb view of the Great Smokies, this living-room window was designed to project slightly, and the window itself is set on a curve. Muntins are placed at 2-ft. intervals along the height of the window. At the right of the living room is a covered porch which overlooks the mountains and also commands, from the side, a view of a nearby lake. The house is a mountain lodge and makes use of characteristic log construction. The surfacing of the wall under the window is  $\frac{3}{8}$ -in. plywood over wood sheathing. Sash and muntins of the window are wood.

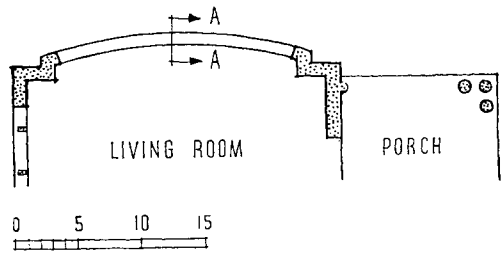
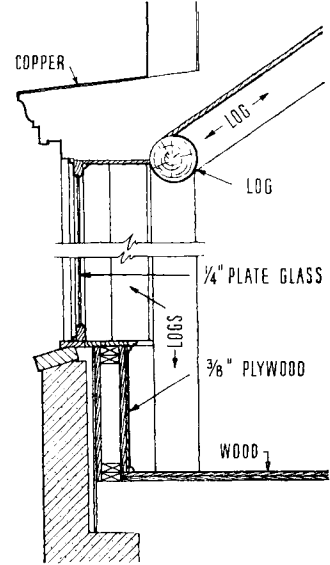

## UNITS VIEW WINDOWS



Roger Sturtevant

### 6. GEORGE WELLINGTON STODDARD

#### Architect

THE VIEW FROM this living room is out toward a lake, and the end of the room was specially designed to take advantage of this. In addition, the window design permits a view of several fine old trees just outside. The colors used in the room—for walls, floors, and furnishings—were chosen to reflect those in the view. The room is illuminated by indirect lights concealed in the cove around the window. There are also lights in the window boxes which silhouette the plants against the window at night.



# DESIGN TRENDS

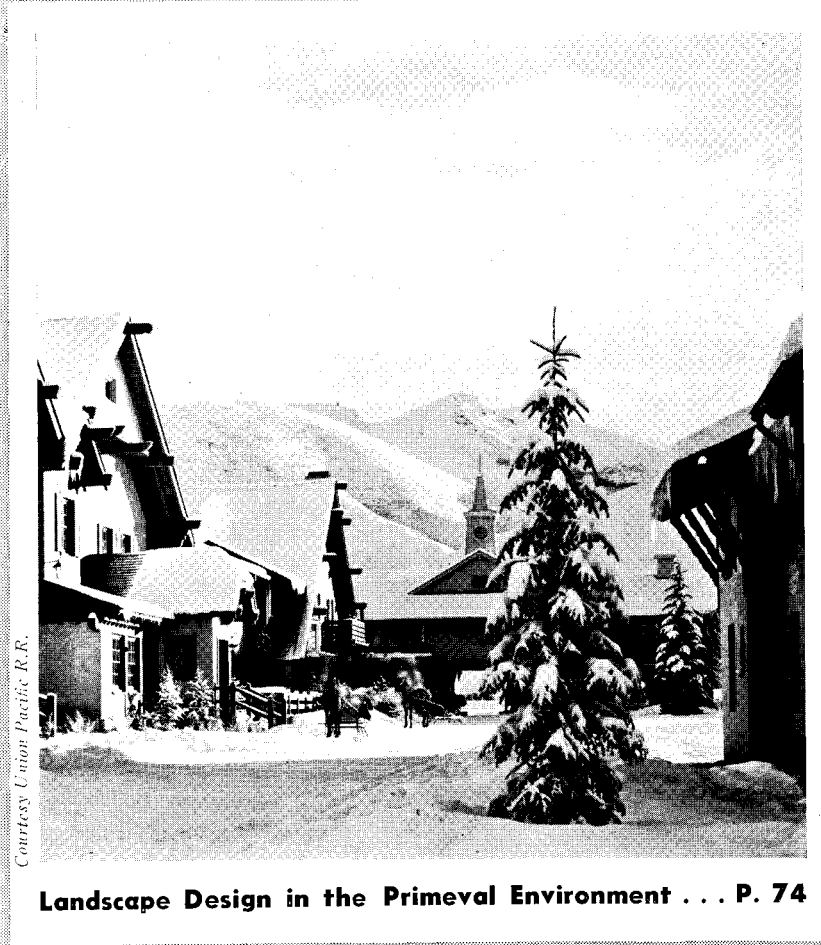

*Courtesy Union Pacific R.R.*

**Landscape Design in the Primeval Environment . . . P. 74**

ARCHITECTURAL  
RECORD



Courtesy U. S. Dep



A mountain cabin by Francis E. Lloyd, Architect.

**WITH INCREASED SHARPNESS**, modern life poses the questions: How can man most constructively use his free time? What accommodations are essential to his recreation? Who will design them? and how? America's rapidly increasing interest in the development of its primeval areas makes this study—last of a series of three—of particular interest. Similar analyses of the urban and rural environments appeared in May and August, 1939, in ARCHITECTURAL RECORD

## LANDSCAPE DESIGN IN T

by Garrett Eckbo, Daniel U. Kiley, James C. Rose

THE AMERICAN PEOPLE had and largely still have a natural environment which is unsurpassed in both scale and variety. But only within the last decade or so have they begun to view it as anything other than an inexhaustible storehouse of material wealth—of minerals, timbers, and furs. Far-sighted Americans long ago realized the cultural, social, and scientific potentialities of the wilderness. In 1812 John James Audubon, patiently recording American wildlife while his contemporaries staked out new claims, lamented that he was not rich again, "so strong is my enthusiasm to enlarge the ornithological knowledge of my country." And later, Thoreau urged "that every community in America should have, as part of its permanent domain, a portion of the wilderness."

But such observers merely anticipated the time when the American people would awake to the fact that they faced, on the one hand, a land from which the primeval was rapidly disappearing and, on the other, a greater need for such environments than ever before. Now—with a population largely concentrated in or near an urban environment—the problem becomes one of *establishing and then controlling an environmental equilibrium*—urban, rural, primeval.

The environmental distinction implied in the word primeval is largely one of time: as such, it denotes that which came first. All habitats and life itself have their origins in the primeval. But the adaptation of the earth and its natural

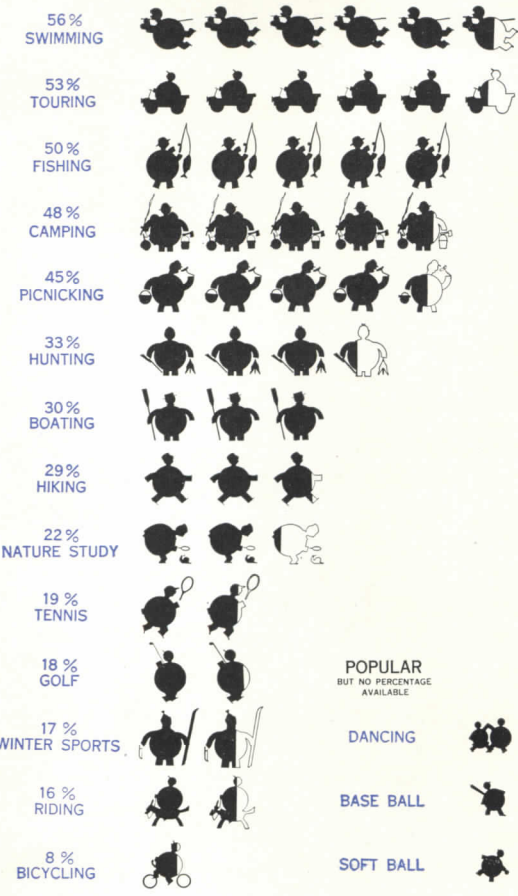

# PRIMEVAL ENVIRONMENT

forces to the needs of various types of organic life has constantly developed new types of habitat, of which the human is only one. The dominance of man is predicated on his having exploited the more primitive forms of life and materials until he has developed what Benton Mackaye defines as "the habitats of fundamental human relations"—urban and rural environments.

The importance of the primeval—its integral relation and the extent to which we are dependent upon it in modern life—is apparent in both a physical (or material) and emotional (or recreational) sense. For instance, trees and other plant forms originate in the wilderness, are developed by science, and are then used in the organization of city streets, playgrounds, gardens, and for the production of fruits and vegetables. Poultry, livestock, and beasts of burden are all products of the wilderness which have been adapted and exploited by man. On the other hand, various forms of life that are not completely domesticated, such as fish, game, and different plants and insects, are often controlled to the extent necessary and desirable for the type of exploitation intended (sport, study, etc.).

The geographical distinction which separates man from the wilderness is produced by the cultural, social, and economic needs of his own advancement, *i.e.*, complicated trade relations, group activity in recreation and work, industrial-

Courtesy U. S. Dept. of Interior



Padilla Studios, Courtesy Santa Fe R.R.



Courtesy Southern Cypress Mfrs. Assn.



Tebbs & Knell, Inc.



J. B. Guss from Black Star



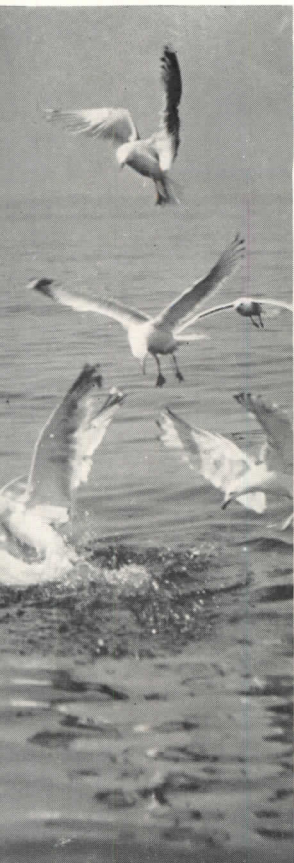

Black Star photos by Anton Komp, Brassai, Milford E. Fields

ization, mobility. These activities fall naturally into geographical centers of easy communication and distribution (water ports, trade posts, etc.), where the urban environment develops, and into centers of agriculture, mining, lumbering (river beds, uplands, and parts of mountain regions), where the rural environment develops. The main factor which distinguishes both the urban and rural from the primeval is that, although the primeval may be exploited by him, *it is not inhabited by man*. This does not mean that it is an "untouchable" wilderness with an arbitrary fence around it. On the contrary, its intimate and tangible relation to both man and the environments which he does inhabit is apparent in the ease with which human habitats return to the primeval (Mayan cities, Stonehenge, archeological ruins, etc.).

#### Design for primeval inhabitants

As all design of the urban environment is based primarily on the needs of the city dweller, and that of the rural environment on the inhabitants of the country, any intelligent planning of the primeval must be based on the *needs of its native "population"*—beasts, birds, insects, and plant life. It is the adaptation of the wilderness to the needs of its own "population"—either by man or nature or both—that provides its chief recreational value to man. Thus, when he controls the survival and selection of the primeval "population," he is at the same time providing for his own.

A primeval system must first establish and then control a dynamic equilibrium between man and nature. This means that we must build up the primeval itself, creating the best conditions which science can provide for the native inhabitants, and protecting them against ruthless invasion and destruction from any form or source (human, animal or insect, fire, flood, etc.).

#### Science shows the way

Recent technological advances at once reveal the complexity of the problem and indicate a trend toward more scientific control of the wilderness. For instance, scientific methods of determining food, feeding, and other wildlife habits, together with a technic for the production and distribution of forage, have in some instances completely reversed the wild-life depletion. At the same time, more than fifty million acres of swamp land, which formerly provided habitat for wild life, have been converted to farm land by advanced methods of drainage. In other sections, zoning of primeval areas has reduced the amount of arable land (particularly in lumbered and burned sections of northern Wisconsin, Minnesota, and Michigan) which can be sold for farm use. This cuts the cost of maintenance on roads to isolated and unproductive farms, and the money is used in reforestation and fire control.

The U. S. Forest Service includes silviculture, nursery and planting methods to insure forest reproduction, selection and breeding of individual trees and tree species to increase future forest values and current forest inventories, as well as sustained-yield forest management. This is undoubtedly one of the most striking examples of a technical service whose planning for primeval inhabitants simultaneously develops the recreational value of the wilderness for man, and concretely benefits both the rural (control of floods and erosion) and urban environments (development of new plant forms). A corollary is the development of new industrial techniques using raw materials, one time abandoned as "waste," on a productive basis in excess of that found in their original use. For instance, 50-60% of the actual lumber grown, or available on the stump, was at one time "waste," but has

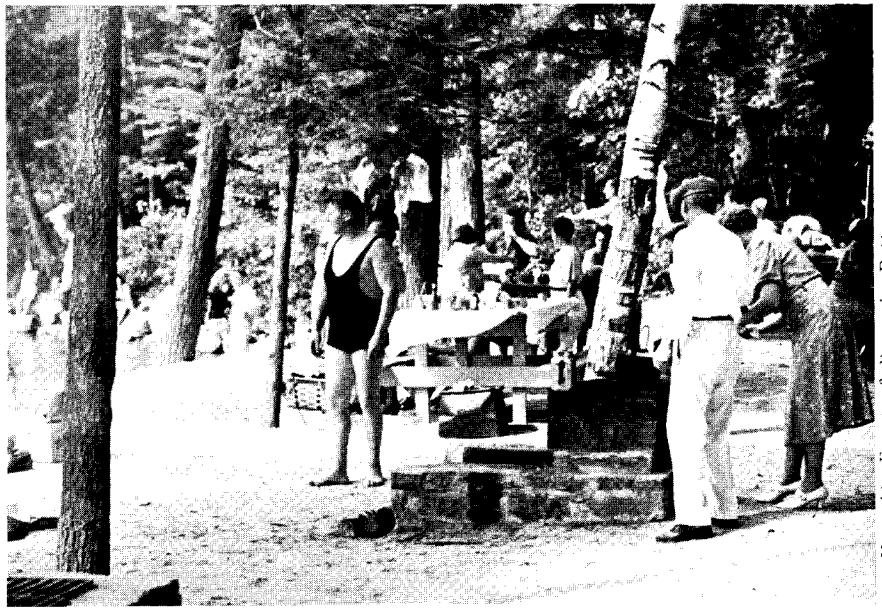

Nat. Park Service, Dept. of the Interior

New Hampshire Forestry & Recreation Dept.

lately become an important source of building materials such as wall board and plywood.

The problem of designing a primeval environment, however, is far larger than the mere development of new methods for utilizing the "left overs," or the "economic" exploitation of raw materials with potential commercial value (salt and borax products from desert areas, for example). For, in planning the primeval, we must consider also its *interplay with the urban* (almost every stream of importance in New Hampshire has been impaired for recreational use by industrial sewage) and the rural (destruction of the Western grass lands equals dust storms in the Mississippi Valley).

Clearly, it is not enough to "establish monuments and reservations" and "preserve the natural scenery." As already pointed out, it is neither possible nor desirable to put a fence around an environment that is a result of complicated and delicately balanced reactions of natural, ecological, and biological forces. Since the primeval is really a distinction of time, what is satisfactory for today may disturb the environmental equilibrium of tomorrow, unless it is shifted and modified to meet new elements in the balance. Even a thoroughly scientific and rational technic can destroy the balance if it considers only one objective.

#### Man in the primeval

Even the fragmentary coordination of technics in the attempt to establish an equilibrium for the plant, animal, and insect life fulfills its purpose, in a qualitative sense, to a greater degree than the specific planning for human enjoyment of the primeval. The majority of our "resort" areas and too many of our parks, although planned to provide man with *access* to the primeval, actually defeat their own purpose—the primeval *retreats* before this advance.

As Lewis Mumford points out, the purpose is "to make the region ready to sustain the richest types of human culture and the fullest span of human life—offering a home to every type of character and disposition and human mood, creating and preserving objective fields of response for man's deeper subjective needs. It is precisely those of us who recognize the value of mechanization and standardization and universalization who must be most alert to the need for providing an equal place for the complementary set of activities . . . the natural as opposed to the human . . . the lonely as opposed to the collective. A habitat planned so as to form a continuous background to a delicately graded scale of human feelings and values is the genuine requisite of a cultivated life."

U. S. Dept. of the Interior



Nat. Park Service, Dept. of the Interior

U. S. Dept. of the Interior



U. S. Dept. of the Interior

Nat. Park Service photo



Union Pacific R.R.

Harold Orne



Haynes Picture Shops, Inc.

As a start toward this end, the Recreation Committee of the National Resources Board has divided the primeval into four classes to meet the varying needs of the population. The following types of activity are recommended to go with the classification:

**DEVELOPED**—specific areas especially equipped for concentrated human use. This is the link which integrates urban and rural with the primeval wilderness. It is the last point designed exclusively for the needs of human activity (and the point from which man goes deeper into the areas designed to satisfy his own subjective and objective need for contact with nature). It includes such recreational types as:

1. camping and picnicking (with facilities provided for both day and vacation needs).
2. summer sports (swimming, diving, boating, beach activities, etc.), including instruction and facilities.
3. winter sports (skiing, tobogganing, bobsledding, ice-boating, etc.).
4. recreational drama, including music, play, and festival organization, amateur and professional productions, summer companies, etc.
5. arts and crafts, including woodcraft skills such as fire lighting and lean-to building, as well as horseback riding, archery, pistol practice, etc.

**SCIENTIFIC**—areas which contain special zoological, botanical, geological, archeological, or historic values especially developed as natural museums or collections for the enlightenment of interested groups or individuals or students of the natural sciences.

**MODIFIED**—areas where man has made alterations with emphasis on the needs of the native population, and some provisions for travel and communication. This includes such activity types as:

1. nature tours, group and individual.
2. camping, with and without facilities provided.
3. practice of arts and crafts, with restrictions.
4. some sports, including hunting, fishing, hiking, cross-country skiing, etc.

**PRIMITIVE**—mainly unexplored or partially explored areas with conditions of transportation as well as vegetation or fauna unmodified by man. The main types of activity are: scientific investigation; study and collection of natural species valuable in cross breeding for the development of new forms; exploration; and satisfaction of the last degree of subjective and emotional need for contact with the primitive.

#### **Design implications . . . access**

It is true that the primeval resources and their ultimate value to man depend upon scientific control, but the extent to which the recreational value thereby created can be used by man depends upon its accessibility. "This does not mean," says Lewis Mumford, "that every type of environment should be equally available to every type of person, and that every part of the natural scene should be as open to dense occupation as the concert hall of a great metropolis. This vulgarization of activities, that are by their essential nature restricted and isolated, would blot out the natural varieties of the habitat, and make the whole world over into a single metropolitan image. In the end, it would mean that one must be content with only one type of environment—that of the metropolis . . . a degradation in both the geological and human sense."

There is, however, a discrepancy between the distribution

of population and the accessibility of primeval recreation which cannot be overlooked. For instance, although 45% of the population in the United States lives within 55 miles of the sea and Great Lake shores, only 1% of this area is available for public use. Inland primeval areas are also insufficiently accessible to urban and rural populations—partly due to occupational shifts and the difficulty and cost of transportation. The situation has been somewhat alleviated by legal processes such as zoning and the right of eminent domain, donations from individuals, public subsidy of transportation, and programs of the state parks.

#### **Towards "the remodeling of the earth"**

But the problem is more qualitative than quantitative since wholesale invasion of the wilderness is by no means desirable. On the other hand, access which is necessary to make the primeval useful in satisfying the varying degrees of human needs cannot be camouflaged out of existence by "styles" of architecture which are supposed to retain the "feeling" of a particular section, or by "rustification" which is supposed to "blend" with nature, and simulate the honest craftsmanship of the pioneers. There is no reason for abandoning the scientific and rational methods of building and construction simply because we come close to nature. The clean cut, graceful forms of the T.V.A. constructions are certainly less destructive of nature than the heavy, often purely ornamental forms used mainly for their association with primitive techniques, rather than because they are the best solution of the problem. The result of such affectation is usually a mutilation of nature which has nothing in its method that is common to that of the pioneer. It cannot be justified even on the aesthetic basis of "harmonizing" with nature. Harmony is the result of contrast: opposites that complement one another.

Thus, we come back to the biological conception of environmental design as found in scientific agriculture, and as exemplified by the life cycle and group habits found in many of the lower organisms. Man's forms must be designed to meet his biologic needs. His social and scientific as well as cultural advancement have placed him in an evolutionary position where he can no longer survive without the protection from the natural elements which science has provided. He has also found that the so-called "fittest of the species" which survive in a struggle on an elementary plane are not always the most desirable, and that the "natural" environment is seldom the best for the optimum development of desirable human, plant, animal, or insect species. Through the application of science he has the means of developing those species which will benefit his own existence and controlling those which do not, and by that method he will retain dominance.

The design principles underlying the planning of the urban, rural, and primeval environments are identical: *use of the best available means to provide for the specific needs of the specific inhabitants; this results in specific forms.* None of these environments stands alone. Every factor in one has its definite influence on the inhabitants of the other, and the necessity of establishing an equilibrium emerges. To be in harmony with the natural forces of renewal and exhaustion, this equilibrium must be dynamic, constantly changing and balancing within the complete environment. It is this fact which makes arbitrary design sterile and meaningless—a negation of science. The real problem is the redesign of man's environments, making them flexible in use, adaptable in form, economical in effort, and productive in bringing to individuals an enlarged horizon of cultural, scientific, and social integrity.

*Compare them all*

**POINT**  
*by*  
**POINT**

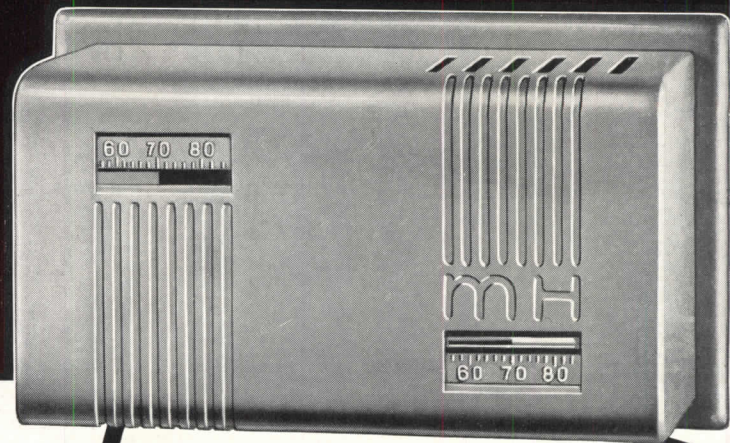

## *The* **GRADUSTAT**

**W**E do not ask you to accept our statements about the superiority of any system of Pneumatic Control. We only ask you to check each unit in the Gradutrol System point by point with any competing system offered. For example, here are eight check points for comparing the Gradustat—the new streamlined Gradutrol Thermostat—with those of any competitive instrument.

Minneapolis-Honeywell Regulator Co., Minneapolis, Minnesota. Canadian Plant: Toronto, Ont. European Plant: London. Factory owned branches in 49 other cities.

- CHECK FOR:**
- ✓ Handsome Appearance
  - ✓ Degree of Efficiency
  - ✓ High Sensitivity
  - ✓ True Graduation
  - ✓ Tamper Protection
  - ✓ Universal Adjustment
  - ✓ High Capacity
  - ✓ Variations Available

**MINNEAPOLIS HONEYWELL** *Gradutrol System*



# BUILDING TYPES

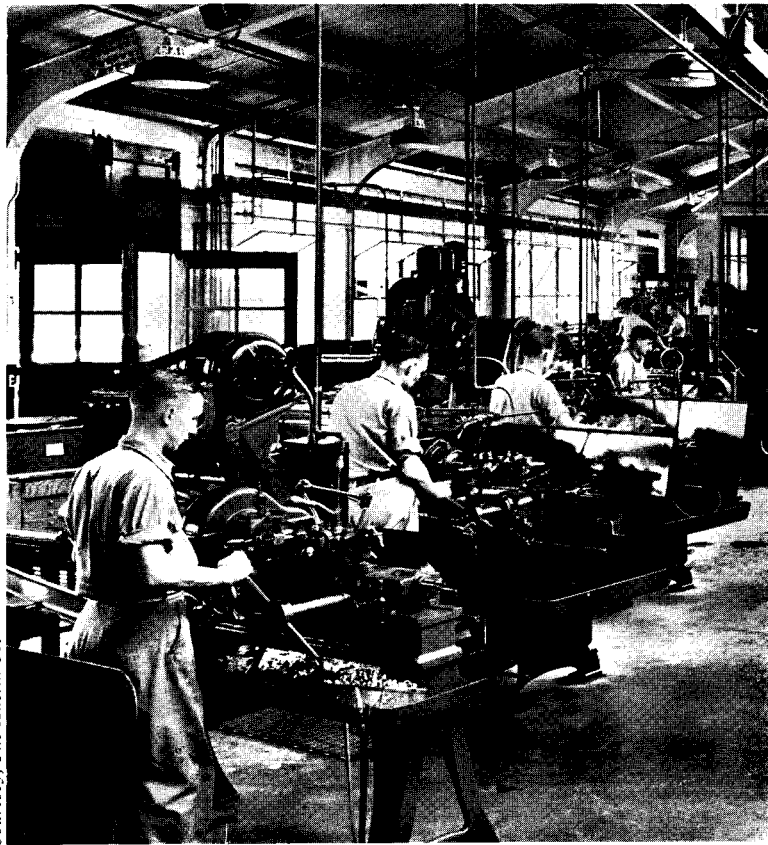

Courtesy, The Anstett Co.

**FACTORY BUILDINGS**

**PRECEDING ISSUES:** 1939-1940 — January, Restaurants and Bars; December, Hospitals; November, Houses; October, Theaters; September, Apartment Houses; August, High Schools; July, Houses. **FORTHCOMING ISSUES:** 1940 — March, Houses; April, Vocational Schools; May, Houses; June, Retail Shopping Centers.

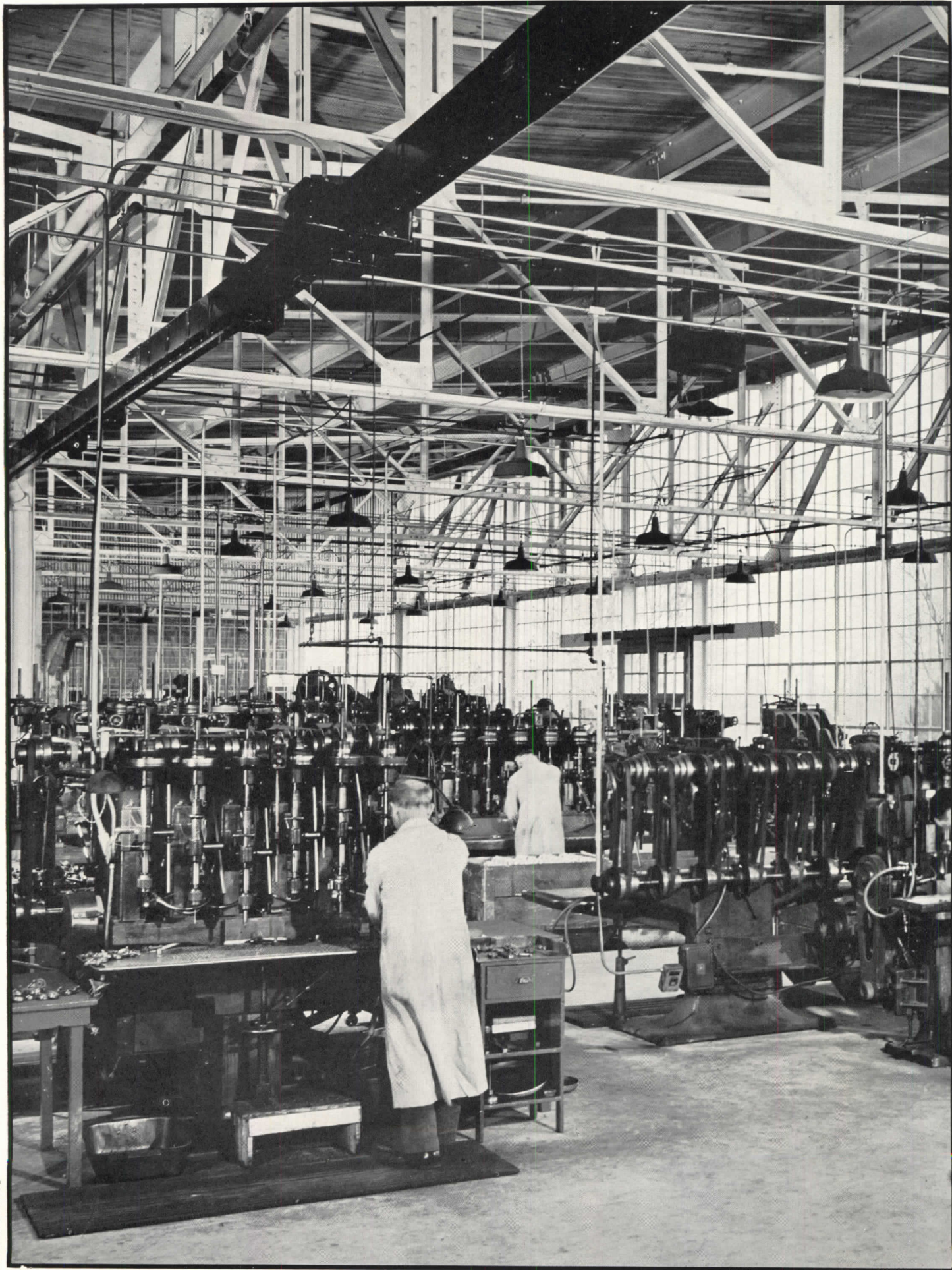

Hedrich-Blessing

# DESIGN FOR MASS PRODUCTION

**A study of Manufacturing Buildings that comments on the current market for factory construction, outlines a realistic approach to the problem of industrial building design, touches on important factors of cost, and lists recommendations of plant engineers on questions of maintenance... Included are descriptive case studies of four factories recently constructed in this country, an outstanding project now under construction in England, and a series of photographic details suggesting trends in the provision of service facilities for employees.**

IT IS GENERALLY admitted that the immediate market for factory construction is large. According to estimates made by the F. W. Dodge Statistical Research Service, the dollar-volume of this type of building will be greater, by over 40%, than that of 1939, which showed approximately the same percentage of increase over 1938 activity.

The Dodge service sets \$240,000,000 as a conservative figure for a 1940 volume of over-all construction of manufacturing buildings (including new and modernization projects) in 37 eastern states. However, the same source emphasizes that many factors may operate to stimulate factory construction and therefore suggests that the volume of \$314,000,000 reached in 1937 may be possible of attainment during this first year of the '40 decade.

These figures, apparently, reflect needs in the manufacturing building classification that are regarded as "normal" results of a comparatively more favorable business situation and a consequent increase in production activity. Economists say that the effect of the European war on American industries has, up to now, been negligible—at least so far as the need for plant expansion and new building is concerned. Furthermore, they apparently hold the belief that this condition will remain substantially unchanged during the current year. This contention is reinforced by statements emanating from industrial corporation officials, and such organizations as the U. S. Chamber of Commerce and the American Manufacturers' Association, condemning plant expansion as a gen-

eral policy based upon activity incident to war. This implies, therefore, that in 1940 factory construction projects will be of substantial, permanent character. They will probably proceed only upon the basis of a carefully considered program of expansion in line with the trend of sound growth evidenced within an industry.

Figures, however, touch merely the size characteristics of the manufacturing building field. To the architect a number of other factors are equally important. Building costs, the type and character of production processes, the elements of growth and obsolescence (which may interact between process, tools, and building), policies of operation and management—all these matters constitute problems that must be solved, not only individually, but in relation to each other. Solutions to them must be developed in terms of current good practices. But, in addition, all elements must be of such a character and so assembled as to make the completed factory in itself a tool for efficient and economical production.

The development of any particular manufacturing plant involves general consideration of many factors that may be common to all others. But upon the way in which all elements of design are adapted to the possibilities and limitations of a particular situation depend both the technical and commercial success of any manufacturing plant. With few exceptions, engineers and industrial executives agree that a factory cannot properly be regarded as a standardized product. The principle of standardiza-

tion has been, and still may be, successfully applied in the design and construction of a manufacturing plant to produce economies in fabrication and field assembly, and to minimize expenses of maintenance or changes incident to expanding operations. But an axiom of production engineers states that, for economy and efficiency, "the plant must be built around the process." And since manufacturing processes are subject to such very wide variations, it follows that factory design is controlled quite as directly by type, program, and cost of production operations and the force of size, locality, and site as by the technical characteristics of structural systems and equipment.

It is essential, therefore, that a factory design be *first* considered as a problem in production. Requirements ought to be researched for every department, operations charted, basic flow patterns developed and studied. In addition, the broad policies of a company control questions such as centralization or decentralization of various manufacturing operations and employee facilities which may bear directly upon building design. All these matters constitute needs that form the basis for layout, structure, and equipment, and make up a check list of "performance standards" to which a building must conform.

This approach to a design problem is one that is understood and welcomed by factory engineers and employed by those architects who have been conspicuously successful in developing outstanding industrial structures.

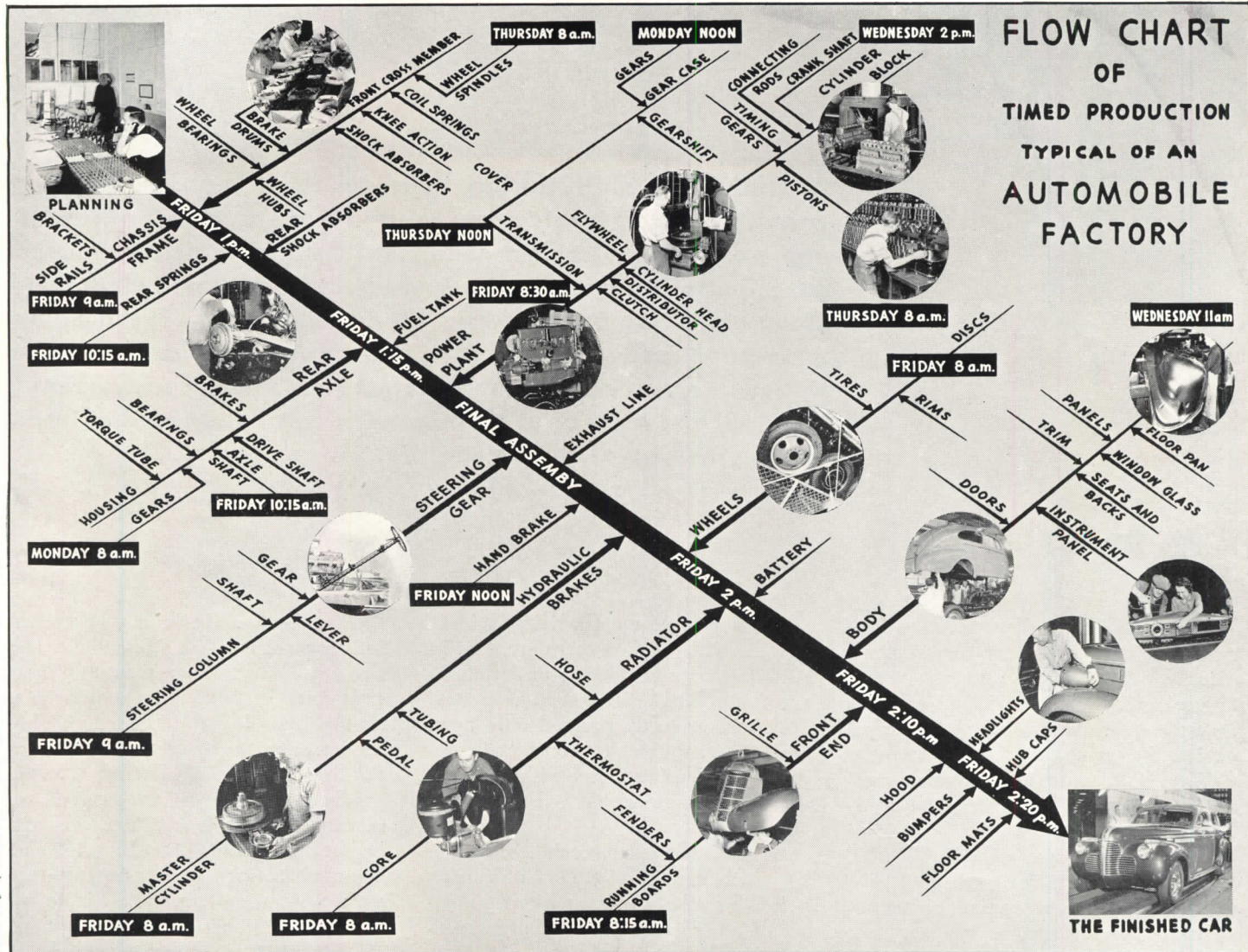

By suggesting the complex problems of modern manufacturing, this chart conveys some idea of the many and involved requirements that a factory must be designed to meet. Though illustrating the production program of an automobile factory, the diagram reflects as well the general principles involved in all quantity manufacturing activities.

Such an analysis will reveal immediately the degree to which zoned specialization, mobility of process, and timed coordination—three controlling principles of modern manufacturing—are applicable. These factors studied in terms of operations necessary to make a particular product will largely determine the general character of a structure. They will establish the type of flow, indicating whether more than one floor level is required; fix required column spacing and clear heights; set load requirements for foundations, floors, columns, trusses; and at least suggest the degree to which interior conditions must be controlled in relation to light, heat, and sound.

Determined also by such a production survey will be not only the relation

of one department, or series of operations, to others, but also requirements necessary and peculiar to each. Areas are thus defined, spaces allocated, and the required characteristics of structure and equipment specified. The plant layout and the specification of building products—the actual design of a factory and the means of meeting these various and interrelated requirements—can then be accurately developed within stated limitations of expenditure.

As concerns trends, the one-story manufacturing plant is commonly regarded as more efficient for most manufacturing operations, more generally flexible in use, better adapted to changes in production involving either expansion or contraction of operations, more easily and economically maintained,

and—usually—less costly to construct and equip than a multistory building.

A trend toward the provision of completely controlled interior conditions throughout the factory is evidenced by the growing number of windowless buildings. Such designs, of course, involve complete air conditioning during both summer and winter and artificial lighting of high average intensity. In contrast to plants daylighted through side wall and monitor sash and heated and ventilated by more simple means, they are costly to construct and maintain. Experience data are still too meagre to prove comparative values from all viewpoints; and, therefore, any decision relating to such controlled conditions must necessarily be based on a detailed study of production needs.

**Costs:** According to Charles A. Haynes, of Albert Kahn, Inc., variations in owner requirements, in building codes, and in prices of labor and materials, make it impossible to develop any square- or cubic-foot cost data that can be safely used as a practical reference or reliable forecast. The question of cost cannot be satisfactorily answered without a survey of general conditions involving plant requirements—product, process, tools, personnel, etc. Mr. Haynes regards the following as particularly important:

1. *Location of site*, involving transportation facilities, location and capacities of utility lines, type of soil conditions that influence structural design, and size and shape of site that may limit means for future expansion or may determine the number of floors.

2. *Type of product*. Each industry—as chemical, textile, machine parts, etc.—presents special problems involving column spacing, floor and building heights, ventilation, lighting, etc., all of which influence plant design and building costs. Requirements may vary even within an industry, depending upon the particular type of product made.

3. *Types of construction* may vary widely within an industry, even in plants for similar products, because of site, financial limitations, local code, or need for specialized building products.

4. *Mechanical services*. Requirements for lighting, power, plumbing, heating, ventilating, and air conditioning vary not only with each industry and individual plant, but also within various operating departments of a manufacturing building.

5. *Employee services* depend on types of personnel, plant size, company policies, and on national, state, and industrial codes. Provision of educational and recreational facilities, conference, welfare, and medical rooms, wash, toilet, and locker rooms, cafeterias, and parking lots is involved. Each element influences cost, which may be further complicated by the type of structure.

6. *Exterior services*, including such items as water tanks and fire lines, floodlighting, fences, watchmen's houses, roads, parking facilities, and landscaping, often involve large sums of money. Furthermore, they are subject to wide variation, depending on insurance companies' requirements, size and location of plant, and the availability and location of general utility facilities.

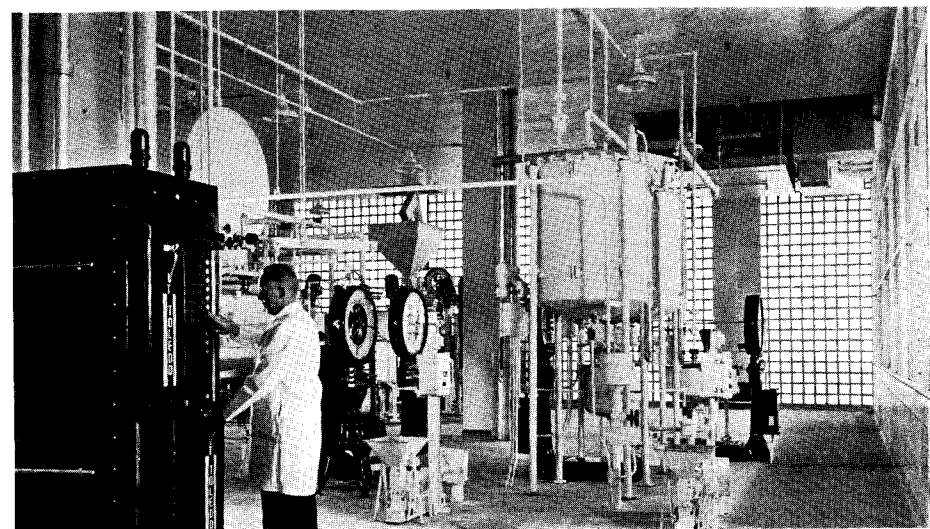
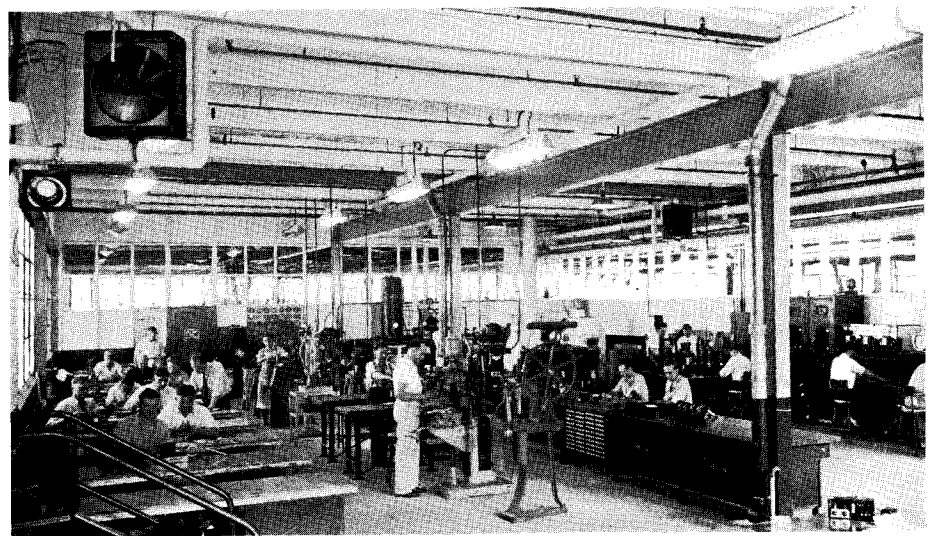

Courtesy The Austin Co.

Hedrich-Blessing

The extent to which type of product and character of manufacturing process control factory design is illustrated in these pictures. Top, assembly department, Monarch Machine Tool Plant; center, development and testing laboratory in factory of the Penn Electric Switch Company; bottom, mixing room in factory of Campana Sales Company.

# PLANTS DESIGNED FOR MODERN QUANTITY PRODUCTION

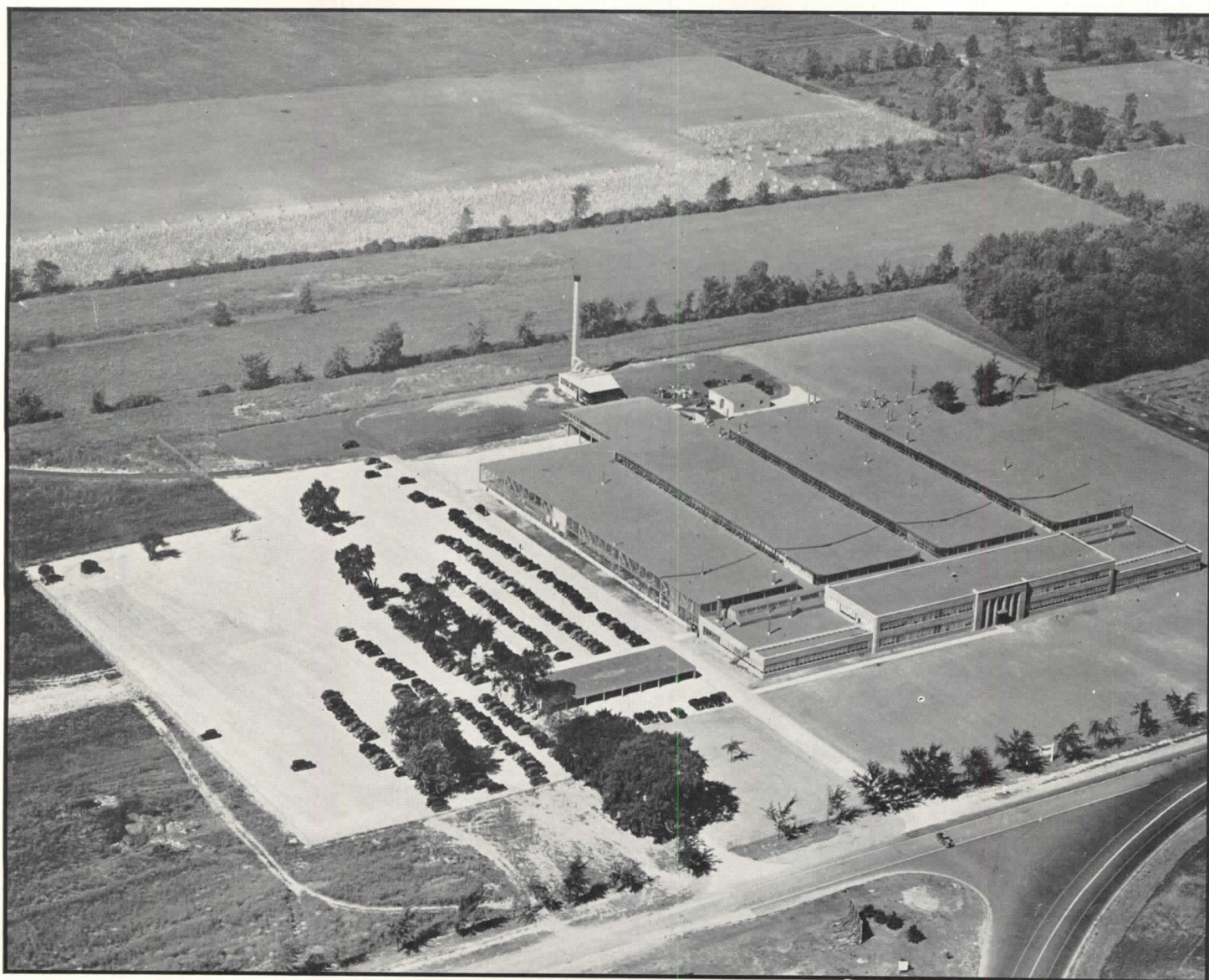

## EFFICIENT NEW PLANT CONSOLIDATES PRODUCTION, SAVES SPACE

**TOLEDO SCALE COMPANY,  
TOLEDO, OHIO**

ALBERT KAHN, INC., Architects and Engineers



*Hedrich-Blessing*

SEVERAL SMALLER PLANTS, located in and around the city, were combined into the single structure here pictured. The move was necessitated because of duplication of manufacturing facilities; lack of economy of transportation, power, supervision, and control; and because the company's direct-sales policy required centralization. Other beneficial results included product improvement both in quality and price, and further improvements in an already highly developed program of employee relationships.

The building shown here is the first unit, which takes care of manufactured parts and assembly of scales. There is ample room on the site for the other units necessary to complete the plant's consolidation. The site also includes parking space for workers' cars, required because public transportation systems are not immediately available.

At the west end of the building ample facilities have been provided for both freight and truck shipping, with a large shipping platform connected directly to the building and covered so trucks may load or unload regardless of weather. The railroad siding serving this platform is also located for the most economical handling of coal direct to the boiler house. Concrete roadways have been located around the building for trucking purposes, and sidewalks for employees' use.

Construction is of steel frame with special light-weight roofing and specially devised trusses; steel is Bethlehem. Bays are 40 by 60 ft.; long spans were needed for flexibility. Hauserman interior partitions and special sections made up of standard Truscon sash units are removable and 100% salvageable. Some wire partitions and some Owens-Illinois glass-block walls were also required. Roof is of planking covered with built-up material. Foundations are concrete (Medusa); exterior walls are common brick, with extensive areas of Truscon sash glazed with Owens-Illinois glass. DuPont paint was used, and Standard plumbing fixtures.

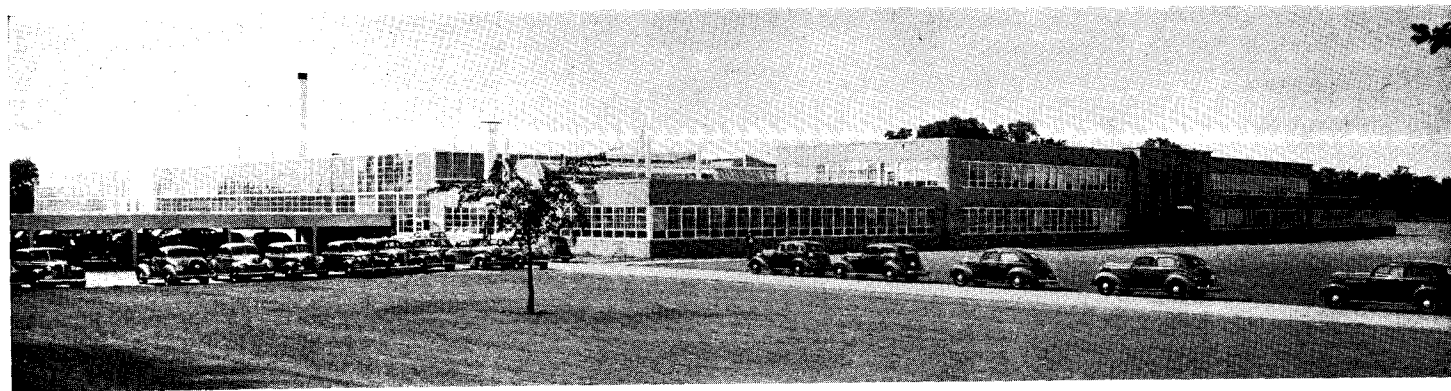
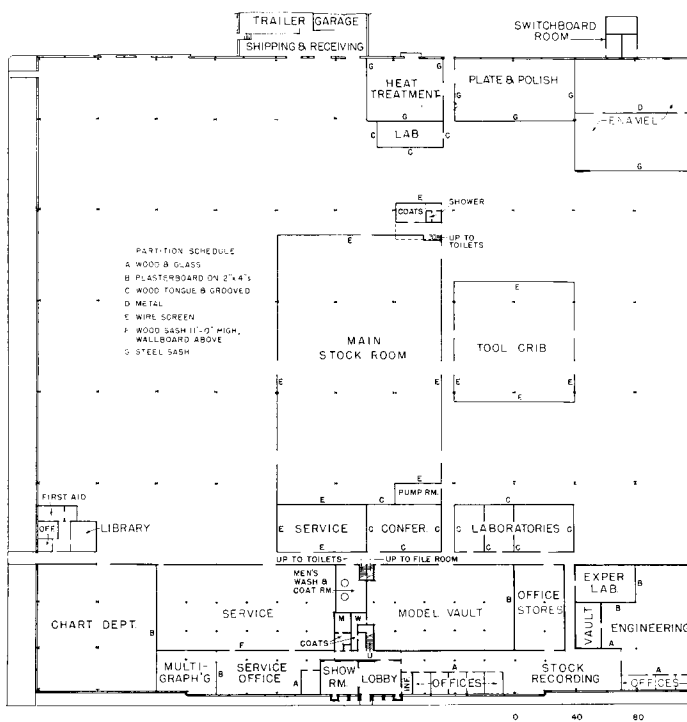
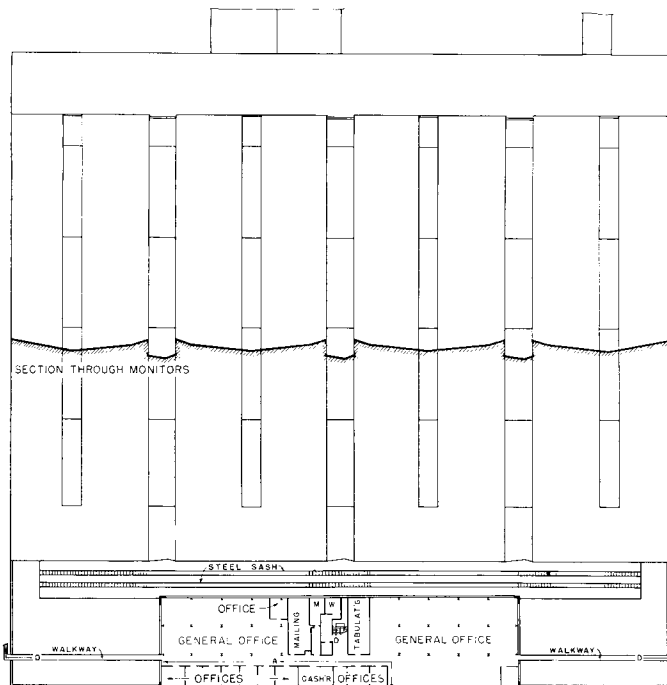

# TOLEDO SCALE FACTORY



Hedrich-Blessing

Vast expanses of glazed walls admit natural light to facilitate processes shown in the flow chart below.

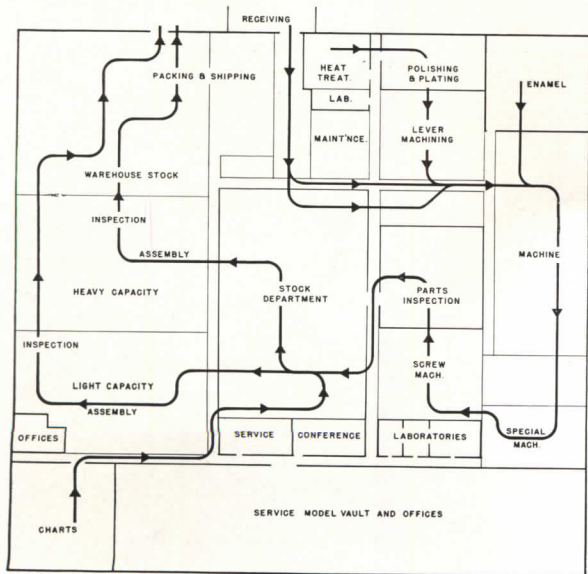

WHEN THE SEQUENCE of manufacturing operations which determined the plant's design was studied, it was realized that mass-production techniques and equipment could not be completely adapted to this project. For example, the line of industrial scales alone includes more than 45,000 standard variations of basic models. This meant that each device would be assembled as an individual unit; and, hence, automatic conveyors or other evidences of high-speed mass production were generally impractical, though heavy castings could be handled on monorails.

However, the flow of materials is planned in a roughly circular pattern to avoid all confusion and backtracking. Material received consists chiefly of castings, stampings, bar stock, and Plaskon items (manufactured by a Toledo subsidiary), and other supplies.

This simple production circle introduced many savings. Inter-plant trucking was reduced from four miles to 400 ft.; all manufacturing operations are on one floor level, eliminating eight elevators; five receiving departments became one; six stock rooms were combined into two. With 7% less floor area than the total in the old plants, the new building makes more usable space available.





General manufacturing area: note new projection-type unit heaters and bus-duct power distribution.



Inspection area: good light is assured by monitor design and by movable direct lighting fixtures fed from trolley ducts.

## TOLEDO SCALE FACTORY

Hedrich-Blessing



Offices closely related to plant operations are on ground floor.



Private office; sales, advertising, and accounting are on second floor.

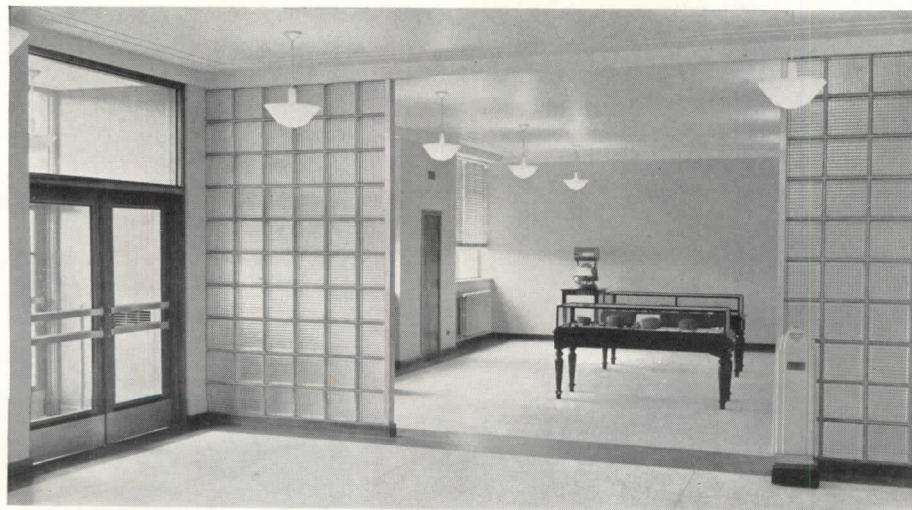

Office-building lobby contains exhibit of historic weighing devices.

OFFICES in the present building were carefully studied in plan to insure well-integrated departmentalization. Engineering service and parts, general plant offices, purchasing, etc.—all operations directly allied to manufacturing processes—are on the ground floor. Others are on the floor above. One entrance is used by factory and office employees alike; there is little distinction. All executives are accessible to any employee.

**Mechanical services.** For general heating for this and future buildings, a boiler-plant building was erected. It contains Keeler boilers equipped with Combustion Engineering Company's Skelly Stoker units. These supply both process steam and steam for the new projection type of Trane unit heaters which heat the manufacturing area. These heaters, located between trusses and actuated by electric motors, draw air in through grille-like radiators and discharge it directly downward at such velocity as to assure even distribution of heat. Provision is made for automatic or hand control, and for recirculating unheated air in summer.

Windows were specially designed to utilize all possible natural ventilation. Air conditioning was not considered essential for this particular installation. Offices are heated by forced hot water, heated by an exchanger coupled to steam boilers.

Fire protection is provided by yard hydrants, automatic sprinklers in factory and offices, and a dry-pipe system in shipping and receiving departments.

Electric service is purchased at 440 V. and transmitted throughout the building by Bulldog bus ducts, which permit great flexibility in locating power machinery. At convenient points dry transformers are connected to bus bars to feed lighting circuits. Switchboards and panels are also Bulldog. Plant lighting fixtures, by the Multi Mfg. Co., are described on page 88. Office fixtures are high intensity Plaskon semi-indirect luminaires, which have 12% downward and 70% upward components. Office ceilings are white for reflective purposes.

# WINDOWLESS—WITH ZONED AIR CONDITIONING, FLUORESCENT LIGHTING



## ALLISON DIVISION, GENERAL MOTORS CORPORATION SPEEDWAY, IND.

THE AUSTIN COMPANY, Designers

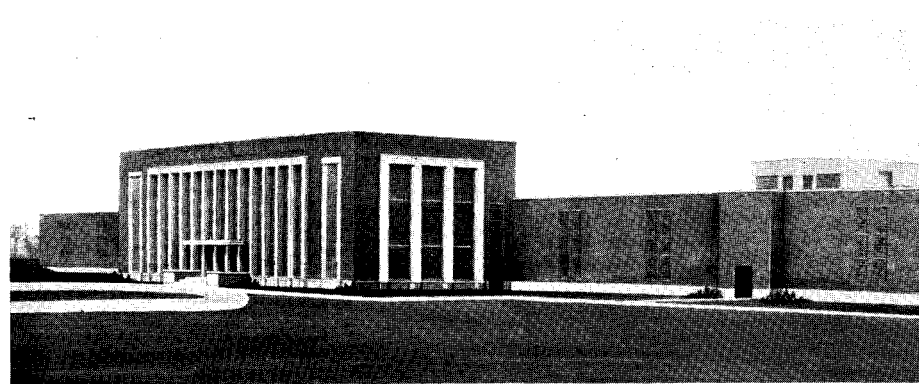

THE ALLISON plant is designed to permit application of high-speed quantity production methods to the manufacture of airplane engines—which require many precise operations. Manufacturing and office buildings and office-building mechanical systems were designed by Austin. General Motors and Allison engineers designed mechanical features of the manufacturing building, with cooperation by Austin.

Among the outstanding features are included: a new combination of standard types of equipment to produce an unusual air-conditioning system; use of a new type of balanced fluorescent lighting; installation of a power system served in parallel by a self-contained Diesel power plant and local utilities; an unusual tooling setup for precision work; and provisions for employee comfort and health.

**ALLISON ENGINE PLANT**

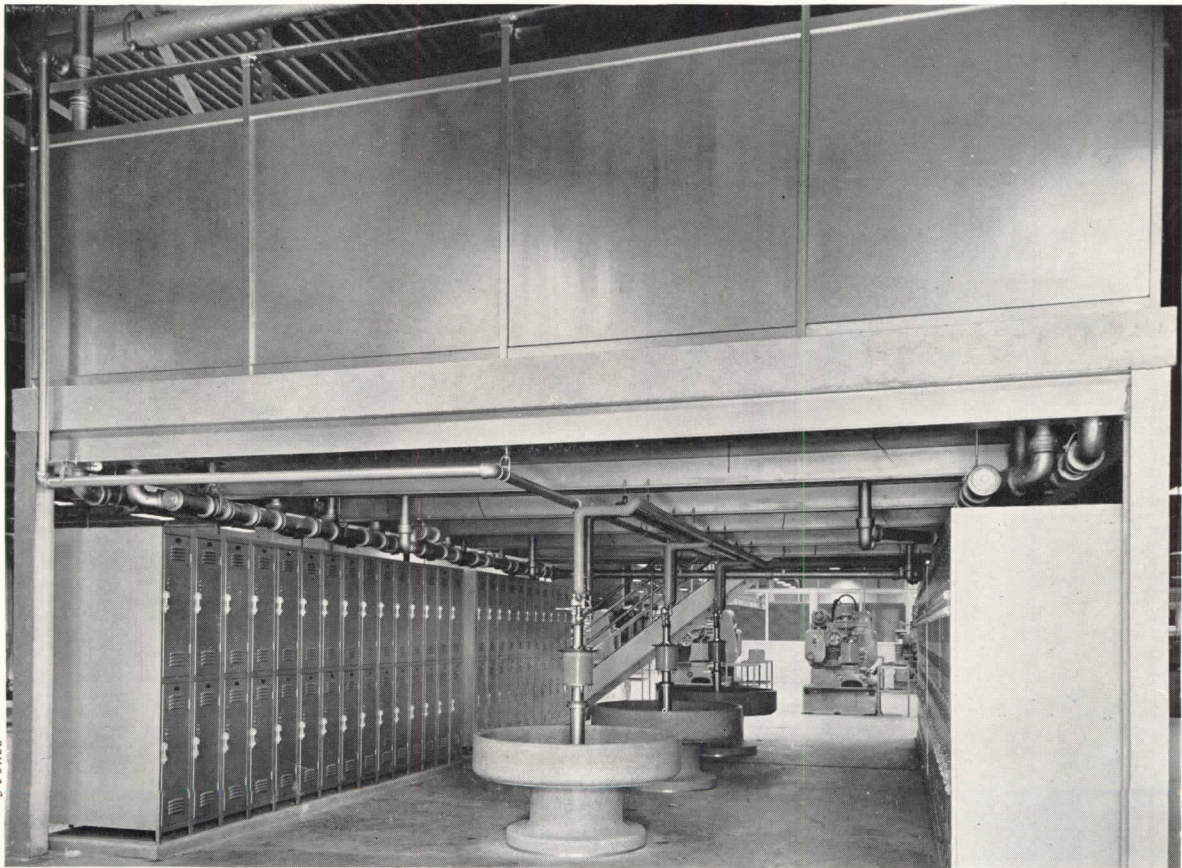
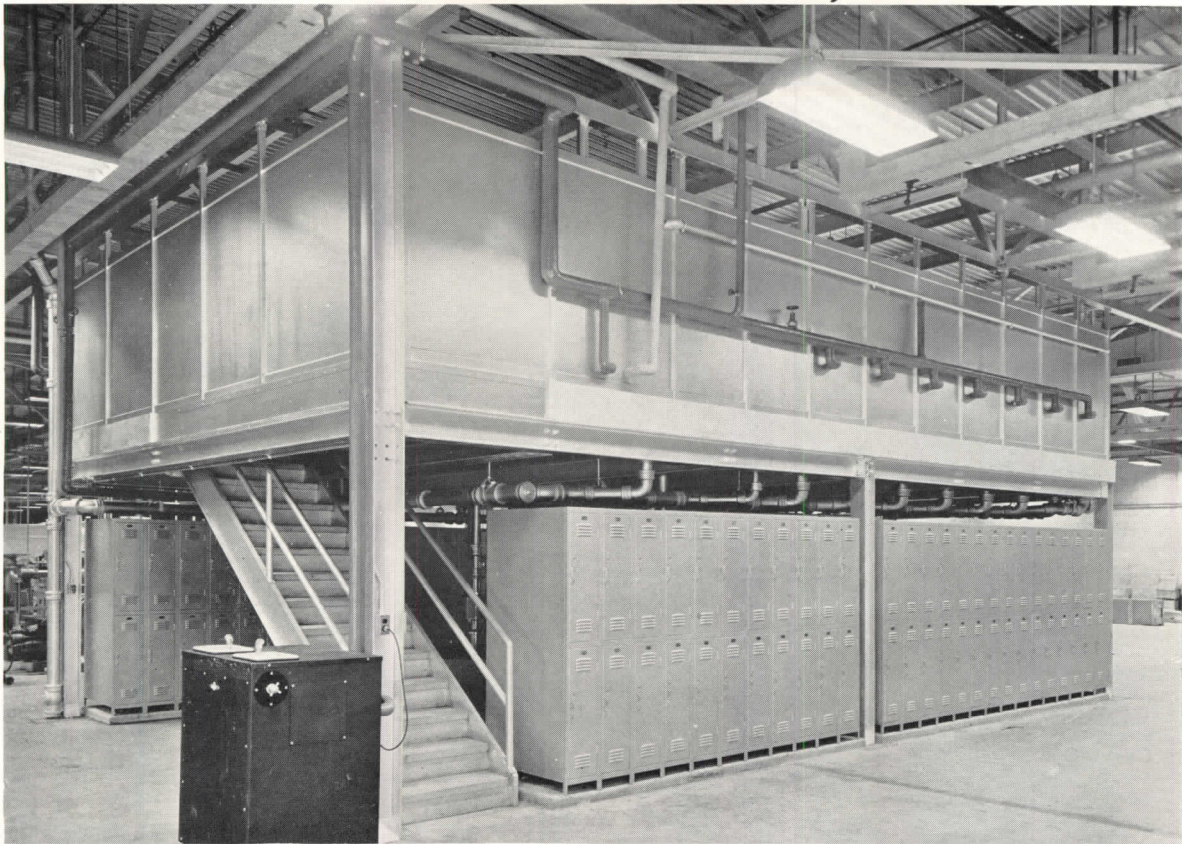

*Photos by Jones*

Two views of one of the three locker-wash-toilet units strategically located on the manufacturing floor; occupying little area, these have mezzanine toilets above lockers which enclose the washfountain space.

THE ALLISON PLANT occupies a 53-acre site in a suburb of Indianapolis, and comprises: manufacturing building, offices, test building, and gate house. In the manufacturing building, steel columns and trusses are welded of Carnegie-Illinois shapes. Exterior walls are face brick with 8-in. concrete-block back-up and Indiana limestone trim. Owens-Illinois glass block is used in the office building. In non-air-conditioned portions of the plant, Truscon sash are used. Robertson steel roof decking is used with Johns-Manville Rigid Roofinsul and built-up roofing. Clearance to bottom of trusses is 15 ft.

Floors are 6-in. Medusa cement concrete, reinforced with Wheeling mesh, and surfaced with Master Builders products. Expansion joints are filled with Carey Elastite. Waterproofing is Johns-Manville. Interior partitions separating buildings are cement block, with some Haydite block used for insulation. Penthouse walls are Johns-Manville corrugated Transite. Robertson roof ventilators have been installed.

The office building is fire-proofed, with steel frame, bar joists, concrete floors, and insulated metal roof deck with built-up surface.

MANUFACTURING and TEST BUILDINGS

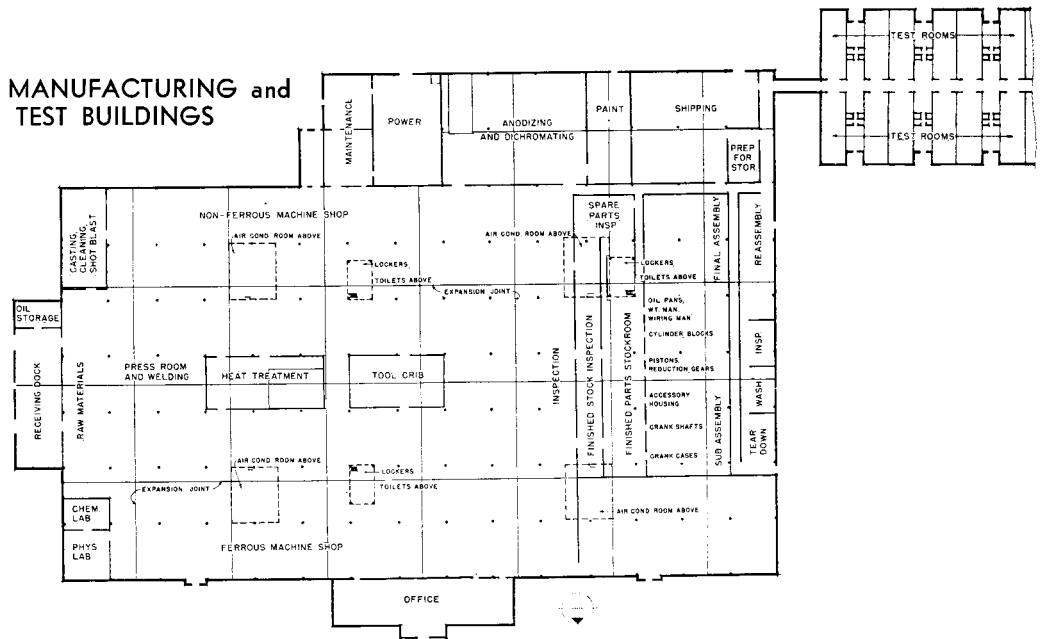

OFFICE BUILDING

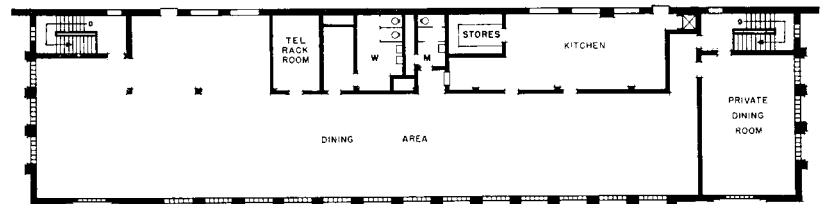

Top floor

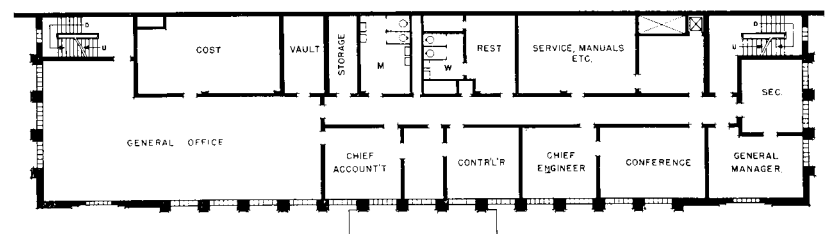

Second floor

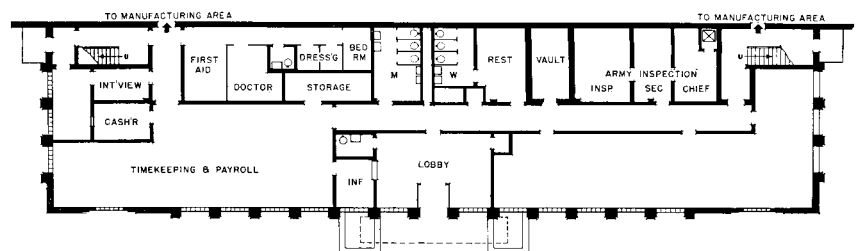

Ground floor

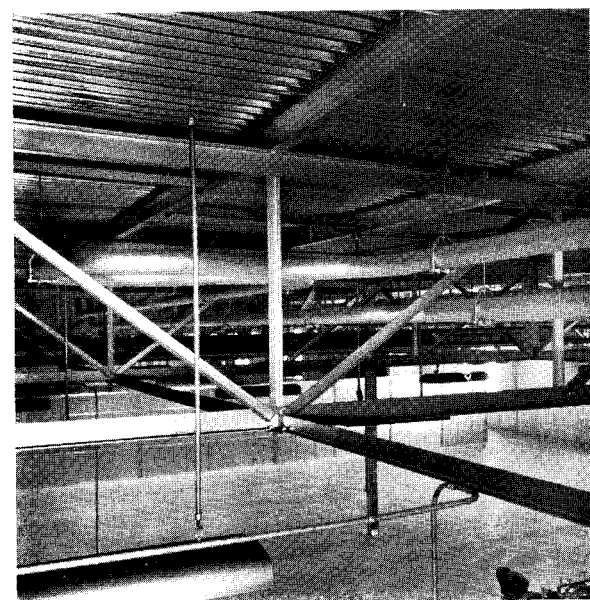

Detail shows method of framing intermediate trusses to bearing trusses, all welded.

## ALLISON ENGINE PLANT

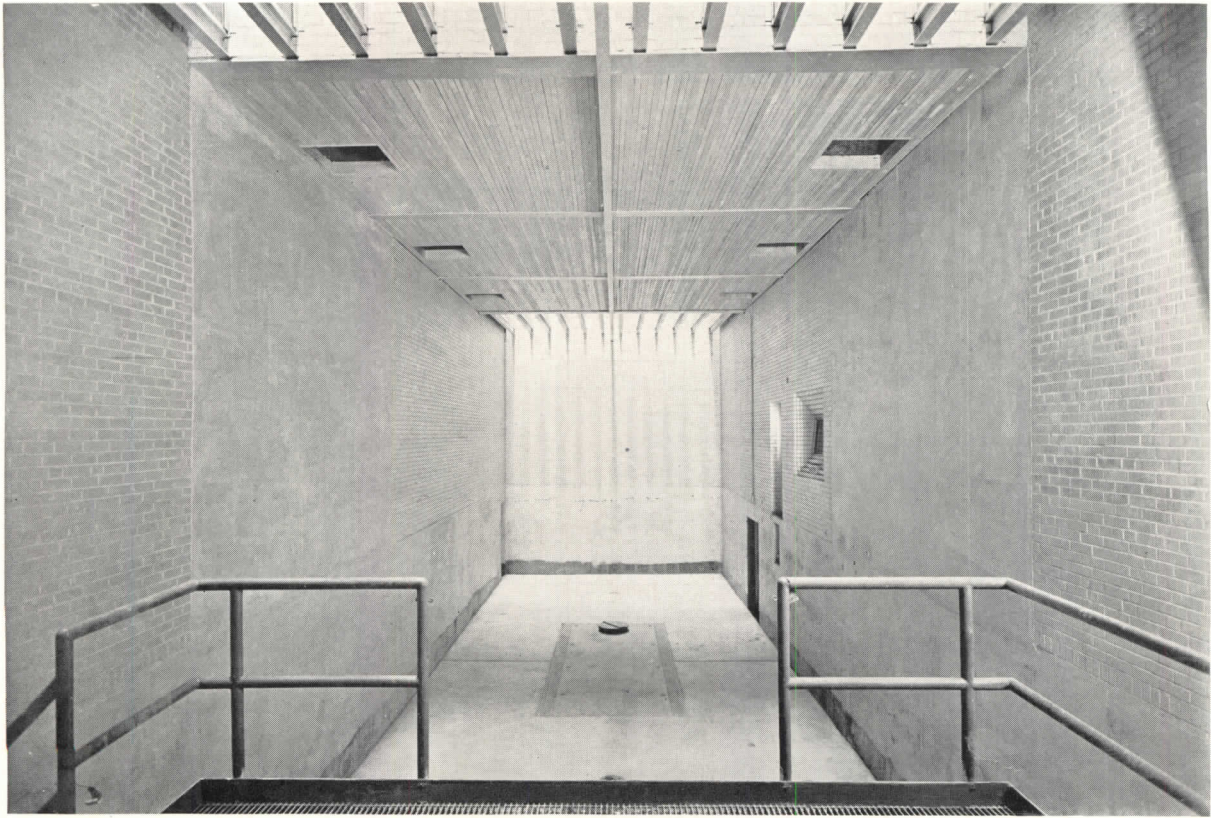

Engine test rooms in the semidetached test building have special reinforced construction, are equipped with two vent stacks each for supplying and discharging air stream actuated by engine propellers.



Photos by Jones

In heat-treat department, furnaces and cooling tanks are sunk in the floor for convenient access, and are serviced from basement rooms into which their lower halves project. Note controls at rear.

**ENVIRONMENTAL CONTROL:** In the factory building, complete air conditioning is necessary for 24-hour work periods in all seasons. An effective temperature of 78°, reportedly most suitable for the occupations involved, was decided upon for the factory building during summer months, and 70° in winter, with the outside temperature at 10° F. Other design criteria include an average of 1000 occupants, 1440 brake horsepower of motors, 250-kw. lighting load, and delivery of 356,000 cu.ft. of air per minute, of which a minimum of 90,000 cu.ft. is fresh air.

Eight independent systems, each capable of delivering 52,000 cu.ft., are provided to avoid overloading in case of breakdown of one or more units. Equipment is designed to take advantage of the condition of natural air in the vicinity of Indianapolis, where required temperature and humidity prevail much of the time; that is, with changes in outdoor conditions more or less fresh air is introduced.

Capillary air conditioners clean the air and maintain humidity. They are located in four penthouses which act as mixing chambers for recirculated and fresh air, and which automatically exhaust excess inside air. One set of Frigidaire coils in each unit serves for both heating and cooling; special eliminators are required to protect the coils from direct moisture. Cooling is accomplished by 54° water from wells on the premises, supplemented by Freon refrigerant. Well water, after it leaves the air conditioners, is used in condensers, in Diesel engine cooling jackets, and for production testing. The well water has to be used indirectly to avoid deposits of carbonates. Compressors are connected to Diesel and motor drives so that the Diesel engines can be used to drive the motors as generators to supplement the plant's power service. Winter heat is obtained from oil burners. Controls are of automatic modulating types, equipped also for manual operation. Double doors and non-air-conditioned spaces serve as air-locks between the plant and the outdoors.

The factory is lighted with Westinghouse fluorescent industrial lighting units mounted 14 ft. 6 in. above floor, approximately on 13-in. centers both ways. Each unit contains three 40-w. lamps in individual reflectors. Each lamp is connected to a different phase of the 3-phase wiring to eliminate flicker sometimes observable in "non-overlapping" units. A transformer-capacitor type of control, which corrects power factor to approximately 92%, is used. The color (specified as 6500° Kelvin) and intensity (28-30 f.c.) of light supplied are designed to provide the equivalent of 92% north daylight—daylight in shade on the north side of a building. To aid visibility, walls, ceiling, and trusses are painted aluminum; and machinery is painted blue-gray.

The plant has its own Diesel-operated power generators, with what is said to be the first complete paralleling of a Diesel-electric plant of this magnitude with public utility power lines. The load can be taken, in whole or part, from either or both sources and transfers automatically in emergencies.



Air conditioning eliminates sweaty finger marks, promotes accuracy.

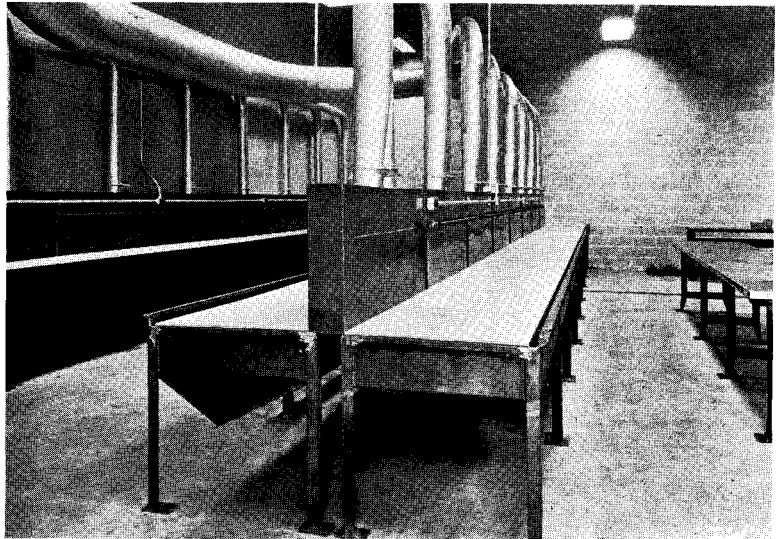

Metal dust is sucked across tables, down slots, into exhaust.

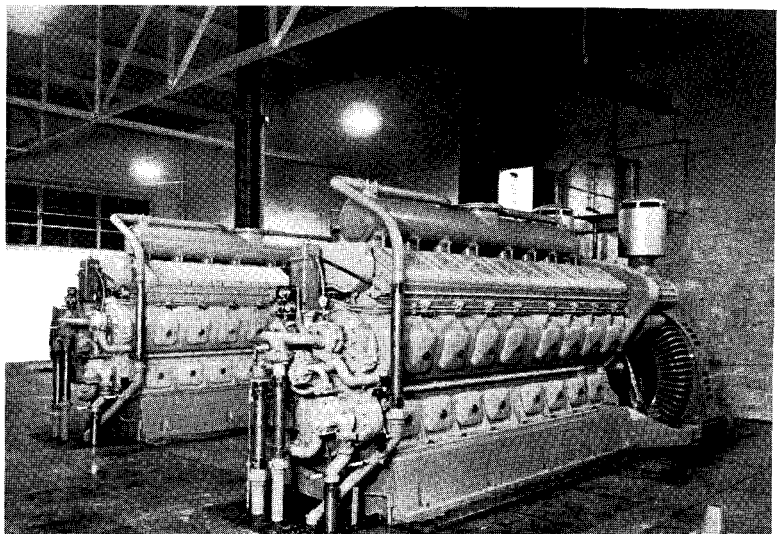

The factory has 3600 h.p. of General Motors Diesel generators.

**PRODUCTION LINES FOR TIN CANS COVER 500,000 SQ. FT.**



**CROWN CAN CO., PHILADELPHIA, PA.**

**LUCIUS R. WHITE, JR., Architect**

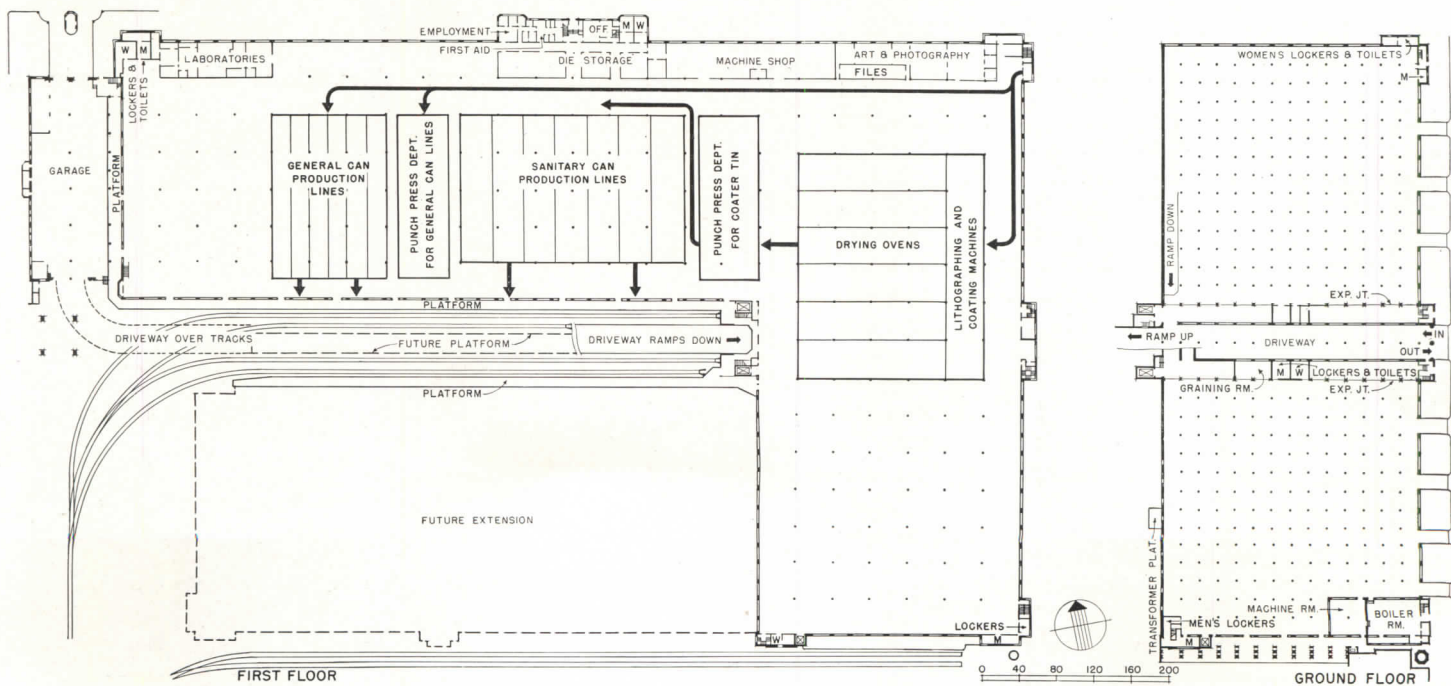



TWO SIMILAR types of products are manufactured in this plant: 1, sanitary and coated cans; 2, uncoated cans. As may be seen from the flow diagram superimposed on the building plan, production is arranged in parallel lines.

The plant consists of four connected buildings, plus a garage-cafeteria unit at the west end, and has provision for future extension. Variations in grade are turned to advantage: the three buildings which compose the east wing have a ground floor and, in the south-east corner, an additional mezzanine (not shown in plan). Also, a truck ramp, which passes through the building over semienclosed railroad sidings, provides double-decked shipping facilities.

The entire production floor—500,000 sq. ft.—is on one level. The ground floor, used for storage, has 30,000 sq. ft. of area. Floor levels are connected by ramps and freight elevators, to expedite movement of materials.

Construction is steel frame and brick, with concrete floors. Roof is insulated with Crown Cork and Seal Co. products. Interior partitions are Johns-Manville Transite. Except over offices, the roof is monitored, with actinic-glass south skylights and plain-glass north lights.

In factory areas heat is provided by Nesbit unit heaters, 14 ft. above floor level, and floor heaters against outer walls. Radiators are used in offices and cafeteria; steam is provided by Erie boilers which have Peabody oil burners and Johnson controls. When heat is not needed, cool air is by-passed around heating coils in unit heaters.

Artificial light in factory areas is obtained from Glassteel diffusers, 20 ft. on centers, with 500 or 1,000-watt lamps, depending on type of work. Fluorescent lighting is used in lithographing department, and combined mercury vapor-incandescent indirect lighting in offices.

Compressed air for testing cans, etc., is provided by Ingersoll-Rand compressors. The sprinkler system is Grinnell; wash fountains are Bradley; lockers are All Steel Equipment.

1, general exterior. 2, lithographing and coating ovens require special venting through roof. 3, machine shop, showing construction of mezzanine above. 4, research laboratories.

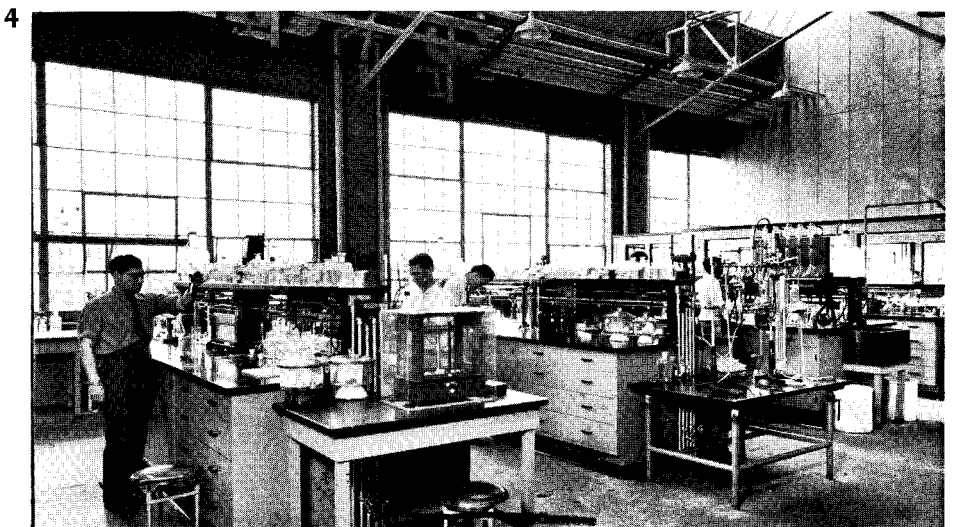
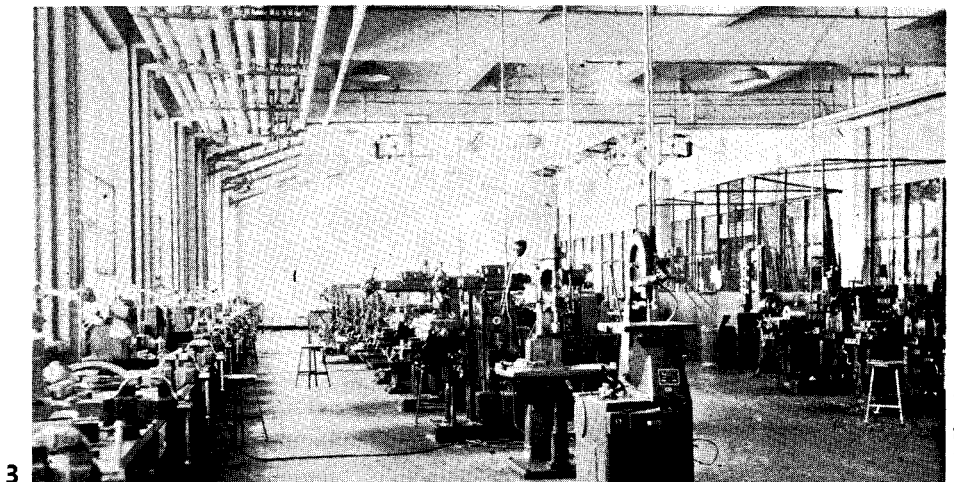
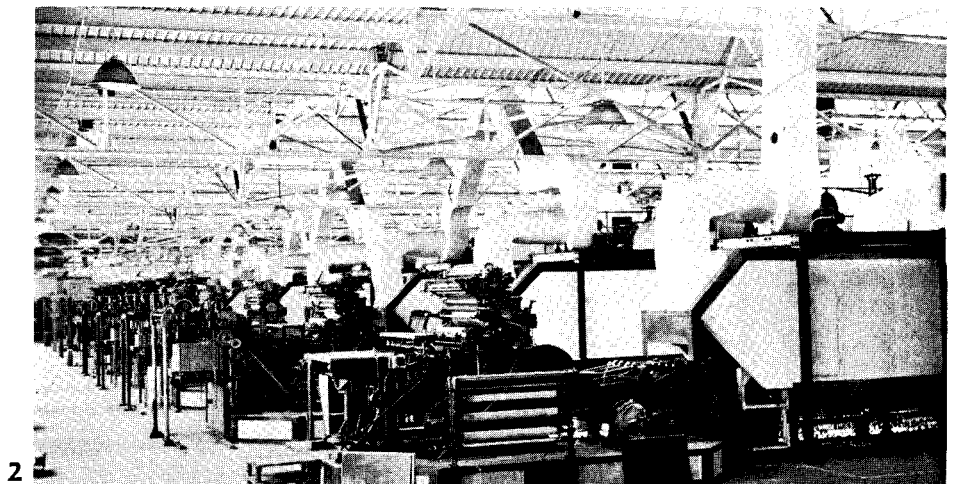
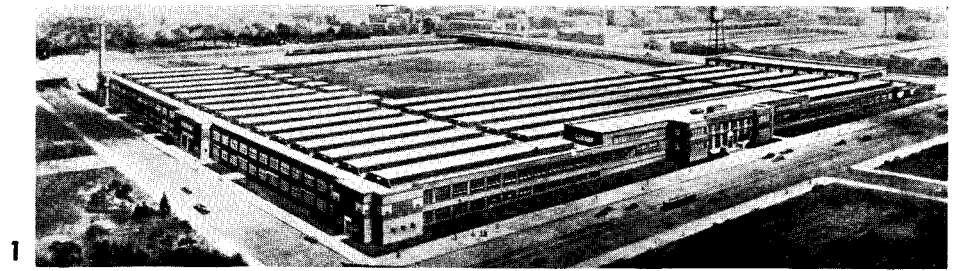

C. C. Harrington

C. C. Harrington

## NORTH-LIGHT MONITORS FOR PRECISION MANUFACTURING



North-light monitors, continuous wall glazing, and structural steel design provide extraordinary daylight conditions.

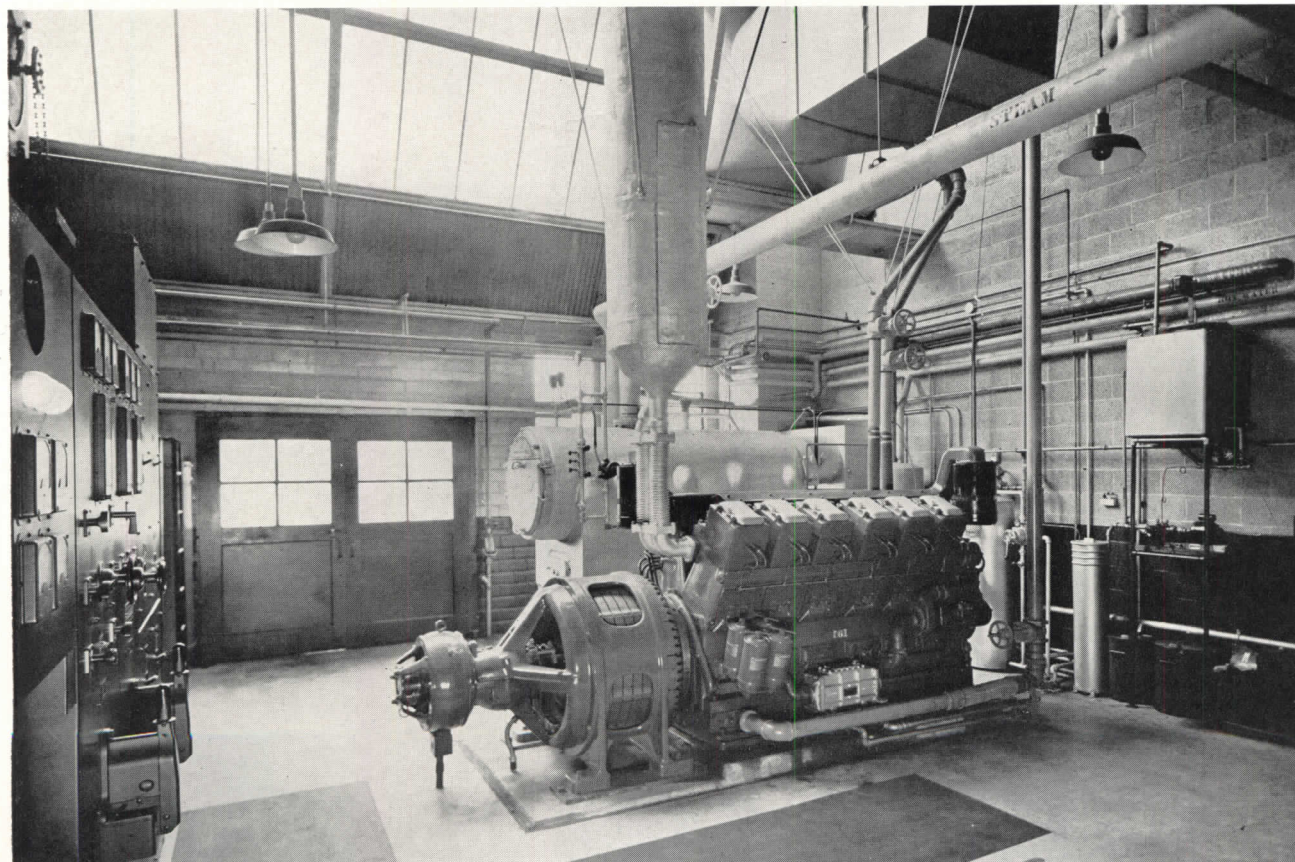

250KW Diesel-powered generator is vented through roof. Boiler room is surrounded by double walls.

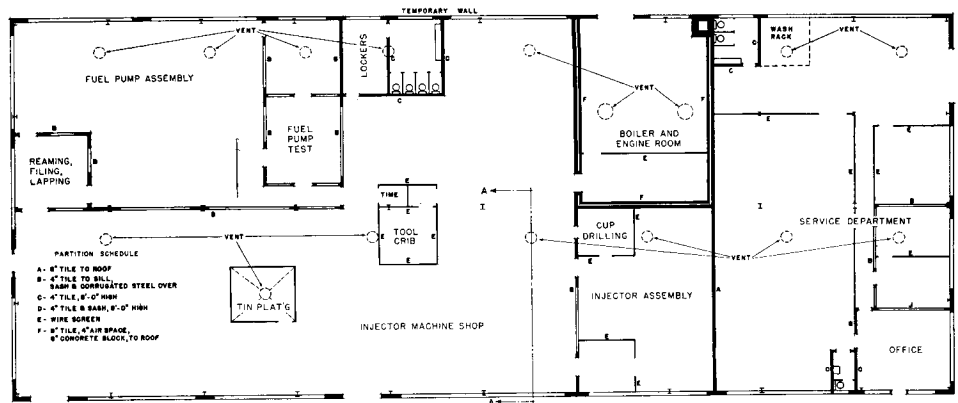
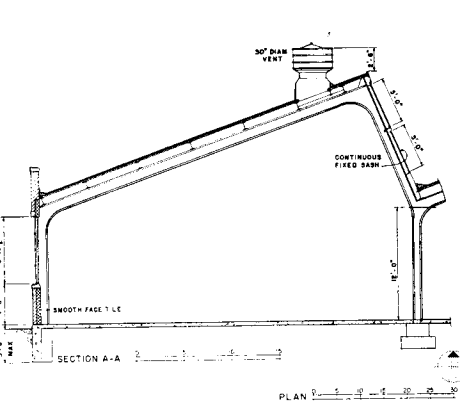

**NEW INJECTOR PLANT**  
**CUMMINS ENGINE COMPANY**  
**COLUMBUS, IND.**  
 THE AUSTIN COMPANY, Designers

FUEL PUMPS and injectors for Diesel engines are manufactured in this plant, which uses welded tree-form rigid steel framing, supplied by Carnegie-Illinois and fabricated by Austin. Shadows cast by members of trusses are eliminated, and north-lighted Truscon sash are installed in sawtooth monitors. Exterior walls have continuous Truscon projected top-hung sash. Roofing is Johns-Manville composition. Most interior partitions are clear glazed; some are clay tile and Truscon "Ferrobord." Although many operations permit tolerances of only .0004 in., natural lighting is ordinarily adequate. All these factors combined have reduced rejects by 25%. Artificial lighting is supplied by Miller "Ivanhoe" high-intensity mercury-mazda fixtures, which provide at least 70 foot-candles at working planes. Current is supplied by a Cummins Diesel-powered generator, synchronized with supplementary power from generators in other Cummins plants. Power is distributed by a Bulldog "Bustribution" system. Many of the Sturtevant unit heaters are equipped with air filters; heat is supplied by a U. S. Radiator boiler with Ray oil burner and Nash condensate pumps. Individual processes are provided with Robertson roof ventilators.

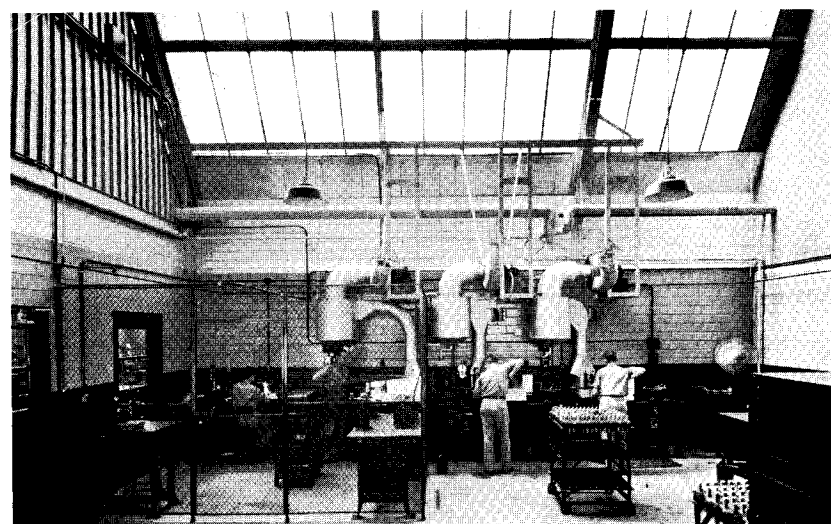
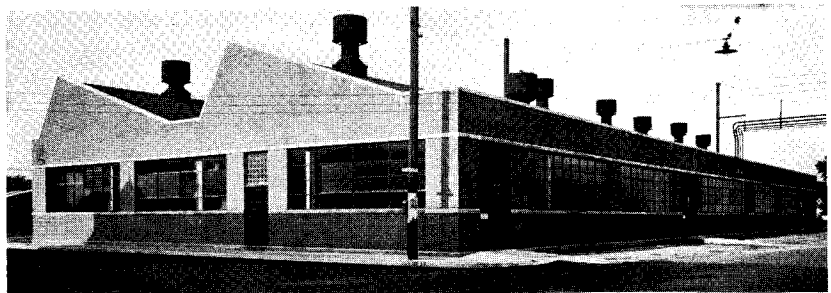

Top, exterior of plant. Center, office in Diesel engine service department. Bottom, completely enclosed injector assembly and test room, where precise operations are performed. Air is filtered; oil-spray collectors (center rear) remove waste oil from air.

# ENGLISH PLANT EMBODIES MANY RECREATION FACILITIES FOR EMPLOYEES

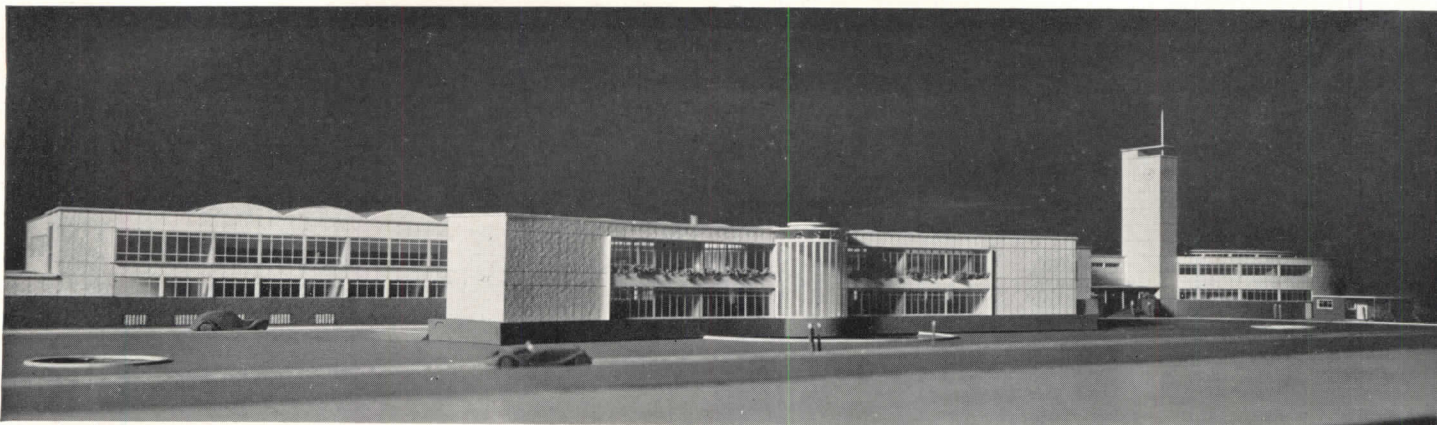

North elevation

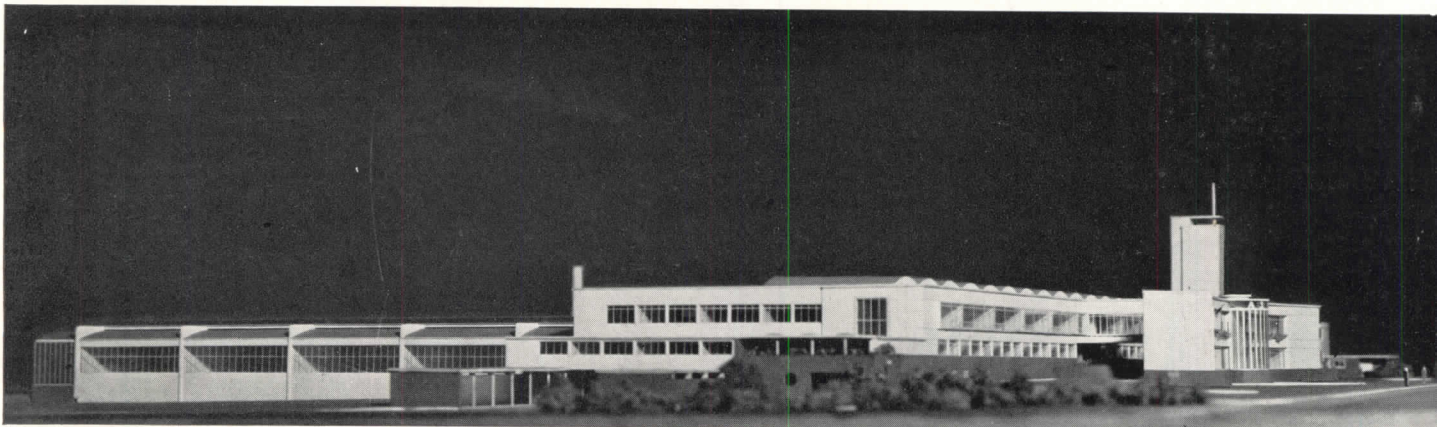

Northeast elevation

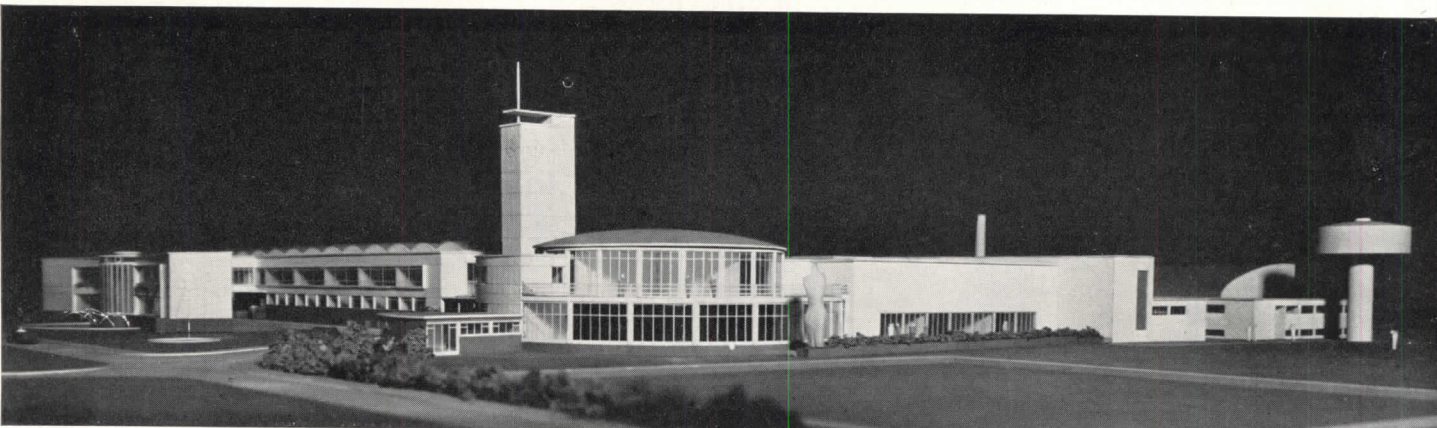

Northwest elevation

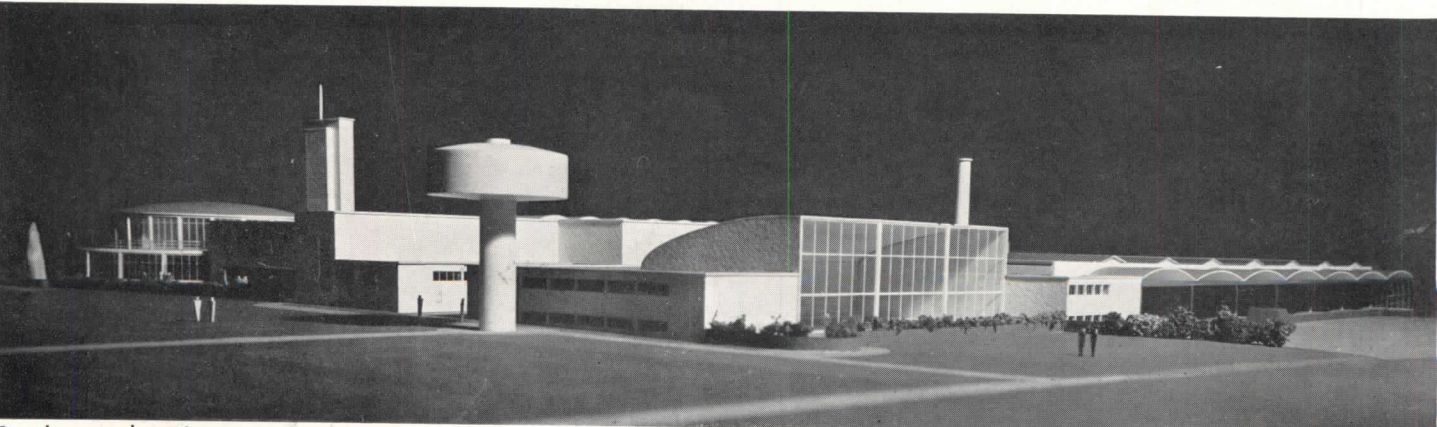

Southwest elevation

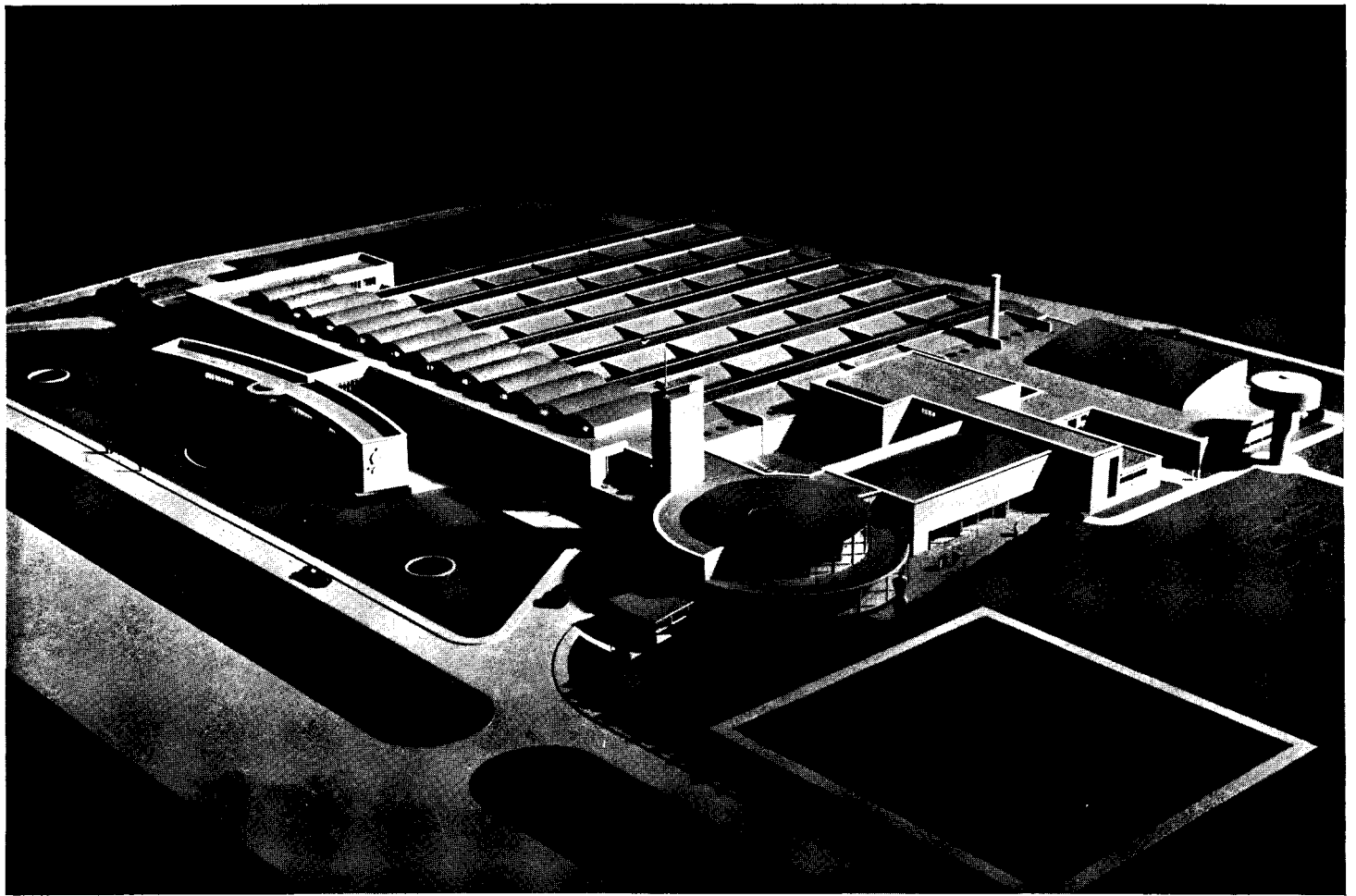

## CHEMICAL FACTORY, BUCKS, ENGLAND

RAYMOND McGRATH, A.R.I.B.A., Architect

STARTED SHORTLY before hostilities broke out in Europe, this factory contains numerous provisions for recreation and comfort, as well as a system of air-raid shelters, all for employees' benefit. As can be seen on the plot plan, approximately half the site is given over to playing fields.

Plans and photographs shown here and on the following pages indicate the results of over a year's study by the architect, engineers, and company representatives. Dotted lines on the plot plan delimit areas for future plant expansion.

The buildings are of reinforced concrete frame construction, with precast slab facings on main facades and brick on other elevations. Floors and roofs are also reinforced concrete, with special diffusing and insulating glazing in skylights. Mechanical systems were designed concurrently with the structure's design, with resulting ease of access to pipe runs, etc. Oil-fired panel heating is employed throughout, except in packing and shipping areas, where convectors are used. Canteens, concert hall, and swimming pool (see overleaf) are artificially ventilated; the plant proper is air-conditioned to provide the constant low humidity necessary for the manufacturing process.

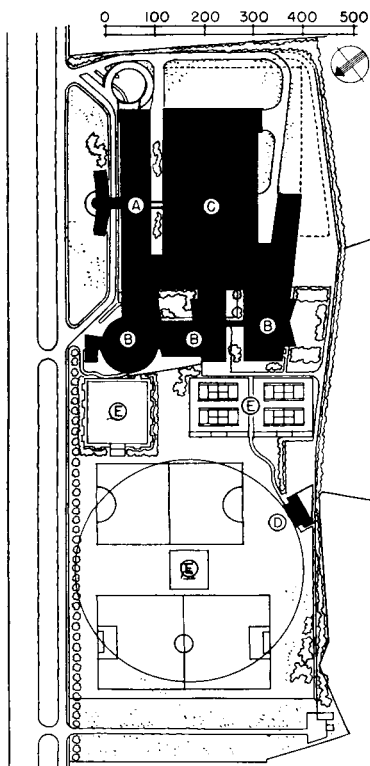

Plot plan indicates extent of employees' playfields. A, offices; B, service and recreation area; C, manufacturing area; D, playfield equipment pavilion; E, bowling greens, tennis courts, football and cricket fields, etc.

# ENGLISH CHEMICAL PLANT

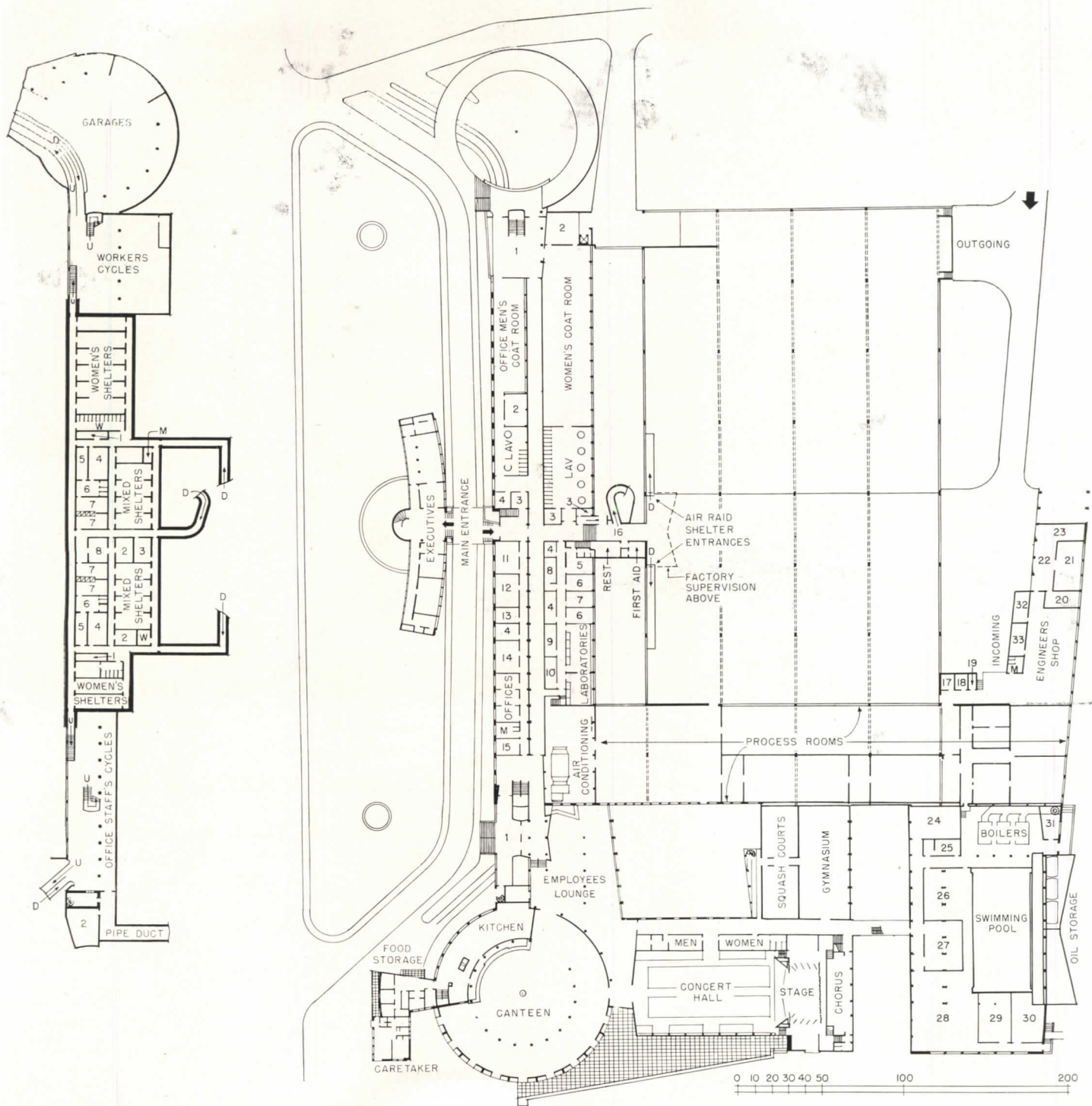

**Basement level contains air-raid shelters**

**Ground floor**

1. Water storage tank
2. Air cond.
3. Diesel drainage
4. Casualty ward
5. Dressing rms.
6. Medical insp.
7. Showers
8. Medical officer

1. Employees' entr. hall
2. Drying rm.
3. Cleaner
4. Store
5. Surgery
6. Chemist
7. Library
8. Dark rm.
9. Sterilizing rm.

10. Balance rm.
11. Traveler rm.
12. Works manager
13. Ass't works manager
14. Chief chemist
15. Night watchman
16. Casualty entr. to A.R.P.
17. Vacuum plant

18. Night staff
19. Kitchen
20. Paint shop
21. Carpentry shop
22. Sawing yard
23. Timber storage
24. Workshop
25. Water systems
26. Calorifier

27. Switch rm.
28. Diesel rm.
29. Swim pool filtration rm.
30. Swim pool ventilating plant
31. Engineer
32. Welding shop
33. Tool storage

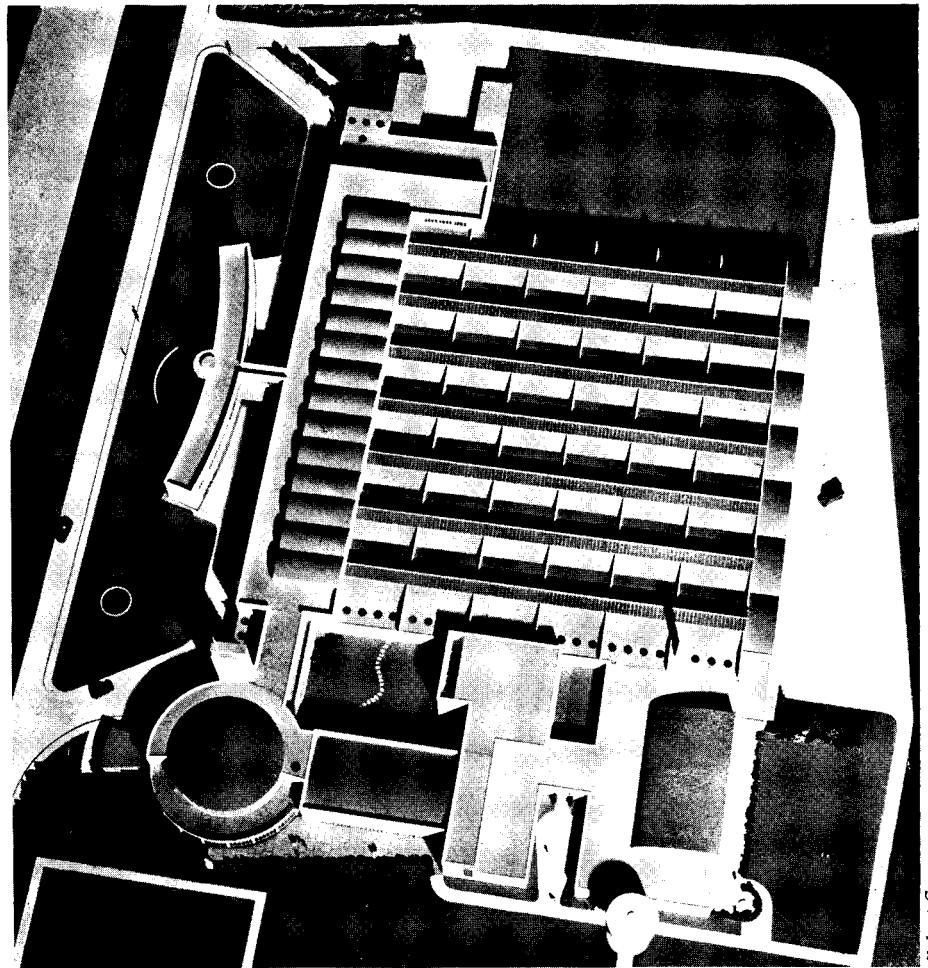

Robert Gee

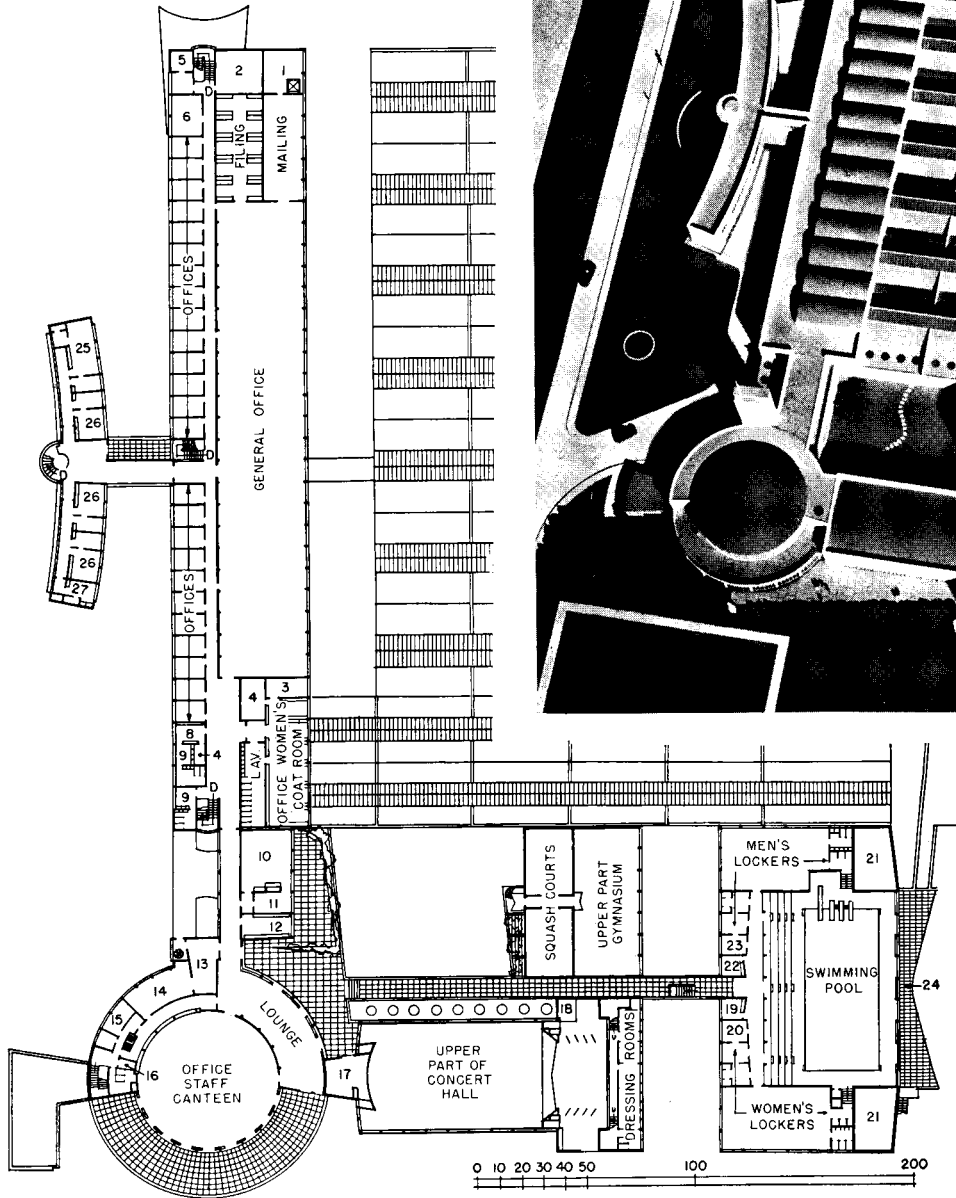

First floor

- |                            |                        |                              |
|----------------------------|------------------------|------------------------------|
| 1. Stationery room         | 10. Directors' lounge  | 20. Women's sunray room      |
| 2. Printing room           | 11. Direc. dining room | 21. Ventilating plant        |
| 3. Rest room               | 12. Library            | 22. Men's attendant          |
| 4. Drying room             | 13. Executives' lounge | 23. Men's sunray room        |
| 5. Strong room             | 14. Exec. dining room  | 24. Solarium                 |
| 6. Buying, costing room    | 15. Kitchen            | 25. Managing director        |
| 7. Telephone operator      | 16. Cashier            | 26. Director                 |
| 8. Office men's coats      | 17. Projection room    | 27. Lavatories and coat room |
| 9. Office men's lavatories | 18. Stage control      |                              |
|                            | 19. Women's attendant  |                              |

IN ADDITION to extensive outdoor recreational areas, special indoor facilities include air-raid shelters, garage and bicycle, storage space, and, besides the canteen, hall, lounge, gymnasium, etc., shown in the plans, dancing and sunbathing terraces, and a garden.

The plant—process, packing, shipping, and storage areas—has a floor area of 80,000 sq. ft.; the general offices, 9,000 sq. ft.

There are separate entrances for plant and office employees. Circulation was the principal planning problem. The manufacturing areas, with their necessary locker rooms, etc., occupy one floor; the offices constitute a separate block; executive offices are another unit; air-raid shelter, equipped with a gas-infiltration plant and planned for 600 employees, is under the main office block, with several feet of earth between its roof and the floor above.



## THE PROBLEM OF EASY MAINTENANCE

**Plant superintendents and factory maintenance engineers contributed these notations on important items of construction and equipment that bear on the problem of easy and economical upkeep. Reflecting experience in a wide range of manufacturing plants and processes, paragraphs on these two pages constitute a suggestive check list as the basis for design involving either new construction or remodeling.**

*The following material was developed from answers to a comprehensive questionnaire. Because of the number of different sources involved, answers have been compiled, compared, edited to avoid duplication, and rewritten as a compact report. As presented it reflects individual opinions which sometimes were in sharp divergence with the majority. It is an interesting fact—though not necessarily an important conclusion—that, in general, answers showed no fundamental differences in practice. However, opinions vary as to relative importance of details.*

### FOUNDATIONS

To prevent damage due to freezing action, it is common practice to carry footings at least 6 in. below the average extreme depth of frost penetration. Waterproofing—integral, applied, or membrane—is considered essential; membrane waterproofing is favored where hydrostatic pressures exist.

**Machines** which need large independent foundations are reported to be those which are least frequently in need of rearrangement. Some plant engineers

prefer to provide for them individually; however, in other plants which have relatively heavy machinery, a uniform 10-in. reinforced slab capable of carrying 250 lb. per sq. ft. is installed. Others have developed continuous extended pit foundations with load-bearing shoulders to accommodate extreme loads and wide dimensional variations. All engineers advocate a maximum of flexibility in machine location.

**Vibration.** Heavy units which cause undue vibration are said to be best located on ground floors, with foundations isolated from floor slabs by joints filled with nontransmitting material, as sand; or by open joints with loose cover plates.

### FLOORS

**Subfloors** are preferably of reinforced concrete. Underfloor services are discussed under "Power."

**Floor surfacing** material varies with the type of service, which may be classified roughly as heavy, medium, or light manufacturing, and special service. For heavy duty, creosoted end-grain wood

block, laid in mastic, is usually considered most satisfactory. For heavy truck traffic, concrete covered with embossed steel surfacing is often recommended. Armored grids are also used. For medium and light duty, concrete, surface-treated with iron or silica compounds, or liquid hardeners, has proven satisfactory. Particularly where trucking of any kind is involved, joint edges in concrete need metal protection. For light duty, 5/4-in. hard-maple strips, on sleepers, have been used.

### FRAMING

**Single-story structures**, particularly those of large extent, are commonly steel-framed, often with long spans which promote flexibility of production equipment. Other advantages include adaptability to various types of monitors, and possibility of adding supplementary framing. However, flat surfaces produced by reinforced concrete framing are stated to be most easily maintained.

**Multistory buildings:** For these, maintenance engineers are almost unanimous in advocating reinforced concrete framing, although some stress the difficulty,



in older structures, of preventing spalling. Such systems as flat slab framing are considered highly desirable.

#### EXTERIOR WALLS

Masonry is preferred, particularly in northern regions; but there is divergence of opinion on materials. Most favor brick, and agree that the frame should be completely covered. Others insist that smooth-finished poured concrete is most easily maintained. However, all agree that monolithic concrete walls are not easily altered; hence, unit masonry on steel is desirable.

In southern climates panel materials, such as asbestos-cement sheets on steel framing, are often used. The same type of construction is usable in the north for plant areas which do not house sedentary activities.

Sound- or heat-absorptive interior wall surfacing, such as block made with insulating aggregates, may be required. Care should be taken so to design these areas that painting, etc., will not impair the wall's insulating efficiency.

Glass masonry, in the opinion of many engineers, has positive value for enclosing areas where a maximum of control of environment is essential to the process. The insulation, light diffusion, and simple maintenance which it affords are considered highly desirable. At present, installation costs are said to outweigh maintenance savings; but other advantages may often become more important than cost.

#### WINDOWS

In general, steel sash constitute the least expensive means of obtaining side-wall light and ventilation; and are easily salvageable. They require periodic repainting and reglazing for continuous service. Many plant engineers believe that larger panes and fewer vent units than are commonly supplied would reduce maintenance. There are some who prefer double-hung wood sash.

**Monitors** are required over areas of great extent for natural lighting. Those with vertical sidewalls are claimed to be most satisfactory, for with them may be used many different types of steel framing; less dirt collects on glazing; and roofing problems are simplified. Sawtooth monitors may save on first costs; and north-lighted sawtooths are often considered most desirable for even, glareless light distribution. Prismatic glass block which directs light downward at an angle may be used in vertical walls for the same purpose.

#### ROOFS

Steel trusses designed for concentrated loads at panel points (for conveyors, hoists, etc.) are preferable. Simple sawtooth trusses are reportedly most economical to install; but welded bents may simplify maintenance problems.

**Construction.** Insulated steel decking has in most cases proven satisfactory as to maintenance. So, of course, have such materials as precast gypsum, concrete (poured or precast), etc.; although conditions may compel use of timber decking, as for instance when minimum initial expense and maximum resistance to corrosion are both imperative. Flat roofs designed for flooding may present leakage hazards; similar evaporative cooling may be obtained from water sprays on sloping roofs.

**Surfacing.** Built-up roofing is almost universally used.

#### HEATING

Most common in shops and manufacturing areas are unit heaters. Use of radiation is almost always confined to offices. Adequacy is the prime consideration; next comes accessibility of all equipment which may require servicing—traps, valves, motors, coils, fans, etc. Nonferrous coils and casings, especially in humidifying and cooling apparatus, are called highly desirable. Year-round air conditioning is recommended where excessive heat loads and poor ventilation exist, or where processes demand.

#### LIGHTING

Incandescent and fluorescent lighting are both termed desirable; so are other forms such as mercury vapor. Design criteria include: design, spacing, and wattage of fixtures for general illumination which will permit an even, comparatively high level of lighting; specification of reflectors which collect as little dust as possible; and adequate wiring capacity so that lamps will be burned at rated voltages. Where needed, local high-intensity lighting to supplement general lighting is believed to be more economical than uniform high-intensity general light. Control switches of the following types are in use: tumbler, wall-mounted; wall-mounted breaker; pull-switch fixture; wall-mounted photoelectric cells. Maintenance factors influencing their selection include: accessibility, operating cycles, protective qualities, and ruggedness of construction. Switches which control limited areas are preferred, for economy.

#### POWER

It is believed that overhead lines are more readily accessible for extension, reconstruction, and maintenance than underground lines; but where general direction of future development can be roughly charted, underground systems, with multiple outlets, can afford equally efficient service. In any event, the system should make service available wherever in the plant it is required. This need not mean complete initial installations, as long as future extension is not restricted.

Except for panelboard distribution, some engineers think cable are more flexible than bus systems; but there are available bus systems designed to overcome this objection. Others believe centralized panel boards, with decentralized controls on each individual machine—unifying the control and machine—are essential. All protective apparatus for power circuits should be located conveniently and accessibly for machine operators or maintenance men.

#### SOUND CONTROL

Control of noise is most readily accomplished by segregating noisy departments. Within these departments, sound-absorbent materials, of types which reduce maintenance, may be applied.

#### OFFICE AREAS

Flooring materials—linoleum, cork, asphalt, or rubber—are preferably patterned or "marbleized" to minimize tracking. Painted plaster or concrete walls are highly satisfactory. Partitions should be readily salvageable.

#### WASHROOMS, LOCKERS

Engineers recommend as general practice that wash basins and lockers share the same area, and that they be located near exits for population served. Vitreous china water closets and urinals, with flush valves; vitreous china lavatories; individual steel lockers; and multiple circular wash units are all essential. Gang showers may be needed in some types of plants.

#### OTHER EMPLOYEE AREAS

In kitchens, cafeterias, and first-aid stations, sanitation, cleanliness, and ease of maintenance should control. Where such materials as tile, terrazzo, or glass are too costly, enamel-painted walls, linoleum floors with metal coved base, and flush metal door bucks may be substituted. It has been demonstrated in many cases that economy results from use of high-quality equipment.

# THE MODERN PLANT BETTERS WORKING CONDITIONS

WHILE FEW American plants at present provide as many and as varied employee facilities as are included in the English chemical plant shown on pages 100-103, there is a definite trend in this country toward bettering the facilities offered, and in a limited degree, toward expanding them. Employers have come to recognize that, just as atmospheric control may substantially benefit precision manufacturing processes, improvement of the human environment enables the workman to do a better job.

On these three pages are shown a few of the ways in which working conditions are being improved. Many others exist; they range from "man-coolers", installed at sources of great heat in manufacturing space (see AR 6/39), to plant offices as modernly equipped and efficiently run as any commercial establishment; from modern safety precautions to powder rooms. Obviously space does not permit inclusion of even a representative number of examples. Those which are shown were selected because they affect the planning, structure, or mechanical systems of manufacturing plants.

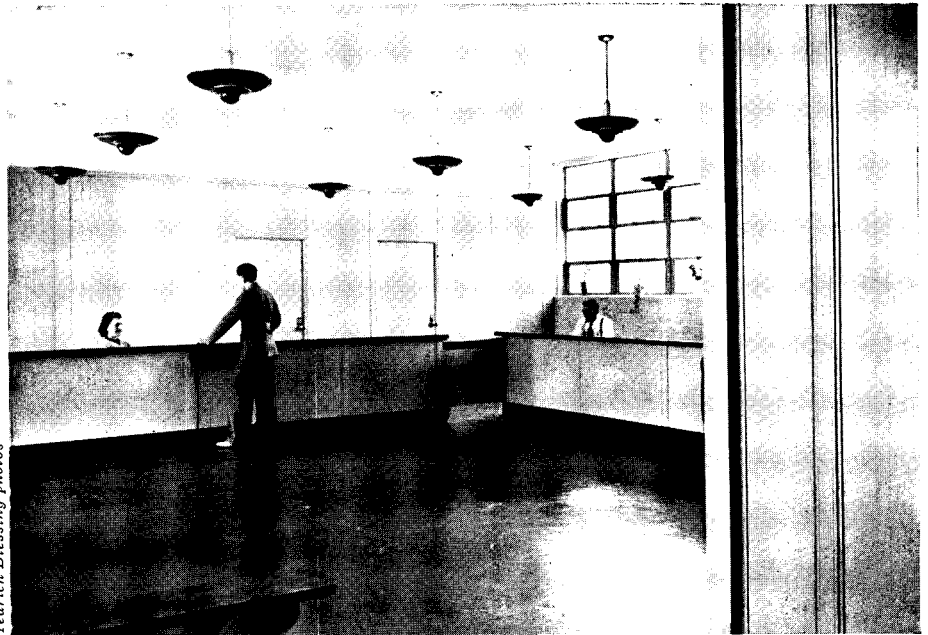
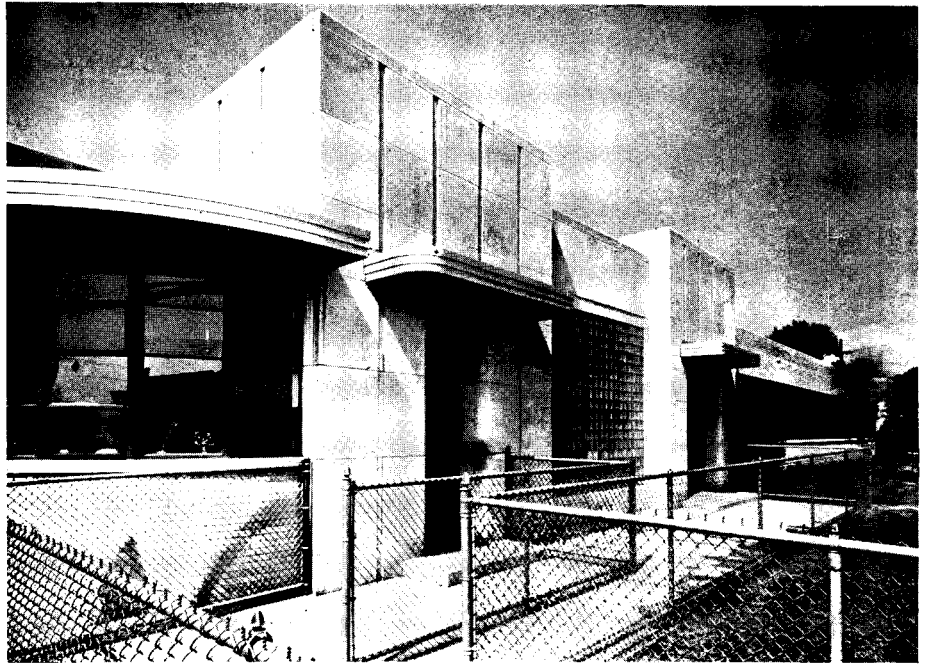

Hedrich-Blessing photos

Exterior and waiting room of the De Soto Employment and Welfare Building, Chrysler Corporation, Detroit, Mich.; Albert Kahn, Inc., architects and engineers.

## EMPLOYMENT AND WELFARE

IN LINE with the development of workmen's compensation, though several years later, provision of hospital facilities for employees has proved profitable. The Chrysler Corporation was sufficiently impressed with its importance to provide ample clinical space.

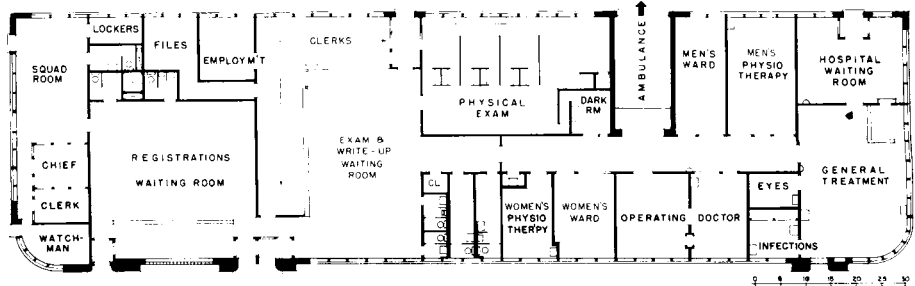

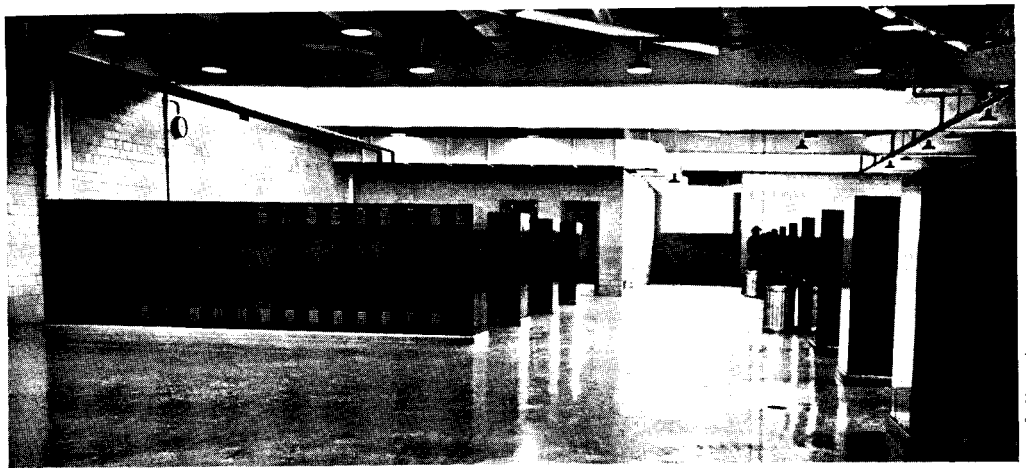

Hill & Knowlton



## LOCKER ROOMS AND WASHROOMS

LOCKERS, washfountains, and showers are commonly used by many workers at peak intervals; at other times they may be completely empty. Hence there is need for extreme care in planning to provide a maximum of comfortably usable facilities in a minimum of space. Such equipment as gang showers and washfountains is increasingly important.

Above, air-conditioned men's locker room, Industrial Rayon Corp. plant; below, factory washroom and lockers, Monarch Machine Tool Co. plant. In one case, a separate room is provided; in the other, part of the factory space is segregated for the purpose.

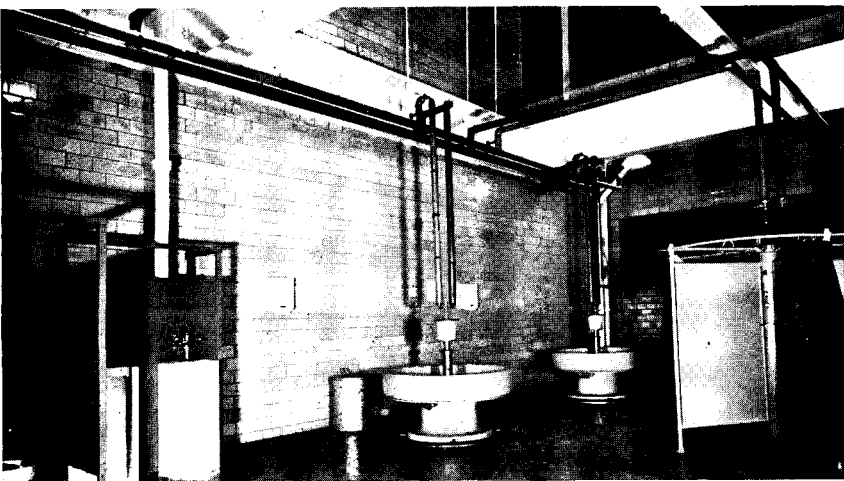

Air-conditioned men's shower and washroom, Industrial Rayon Corp.; Wilbur Watson & Associates, engineers.



Women's locker room, Monarch Machine Tool Co.; Schenk & Williams, architects.

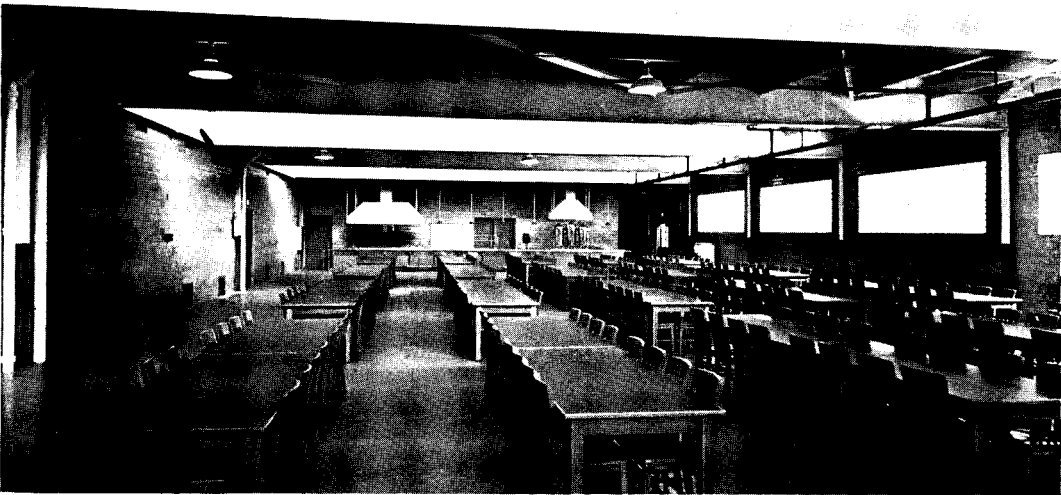
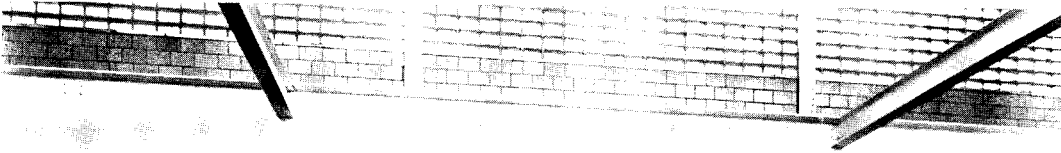
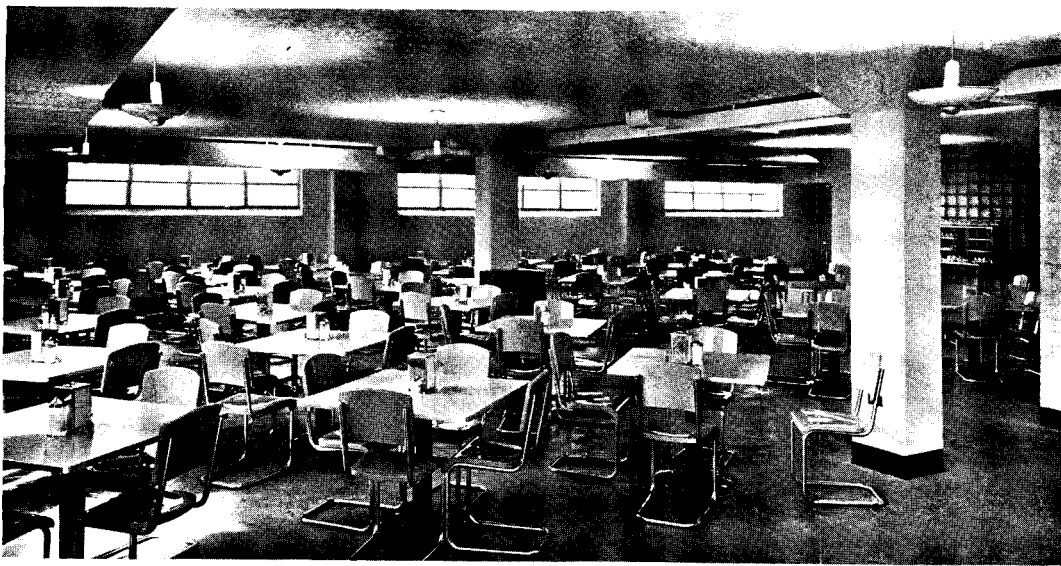

Hill & Knowlton



Hedrich-Blessing

Top: Air-conditioned, indirectly lighted dining room, Monarch Tool Co. plant. Center: Air-conditioned cafeteria, Industrial Rayon Corporation plant, Painesville, Ohio. Bottom: Glass block furnishes natural light, cafeteria, Campana Sales Co. plant, Batavia, Ill.; F. D. Chase and Childs & Smith, architects and engineers.

## CAFETERIAS AND DINING ROOMS

PARTICULARLY when the plant is in an outlying district, with few local eating places, does it need to provide eating facilities for its employees. However, the practice is by no means confined to such plants, for many in urban localities have their own cafeterias.

For his "CATHEDRAL OF MODERN BUSINESS"

Frank Lloyd Wright Specified

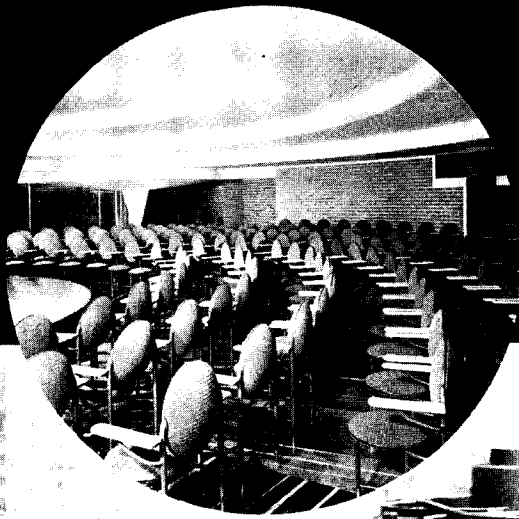

ELECTROL  
SCREEN

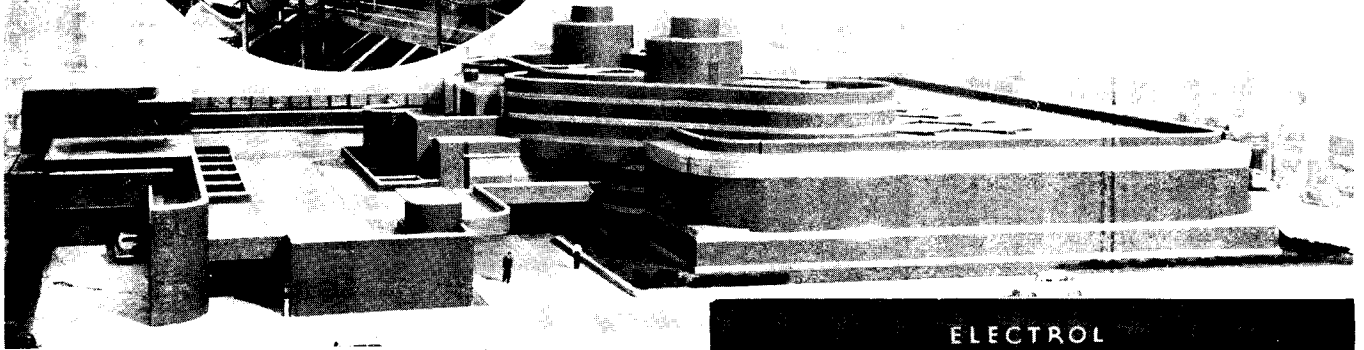

**I**N THE 250-SEAT THEATER of the new, modern plant of S. C. Johnson & Sons, Inc., makers of Johnson's Wax, Racine, Wisconsin, the electrically operated Da-Lite Electrol Screen provides maximum convenience.

The selection of a Da-Lite Screen by Frank Lloyd Wright for this most modern plant is further tribute to the efficiency and superior quality of Da-Lite equipment.

The Electrol Screen is operated entirely by electrical control. A motor and gear drive unrolls and rerolls the fabric, stopping it automatically when completely lowered or completely re-wound. Because speed is constant there is never any strain on the fabric. The Electrol can be hung from wall or ceiling or can be installed in recesses. It is ideal for large classrooms and auditoriums. It is available with white or

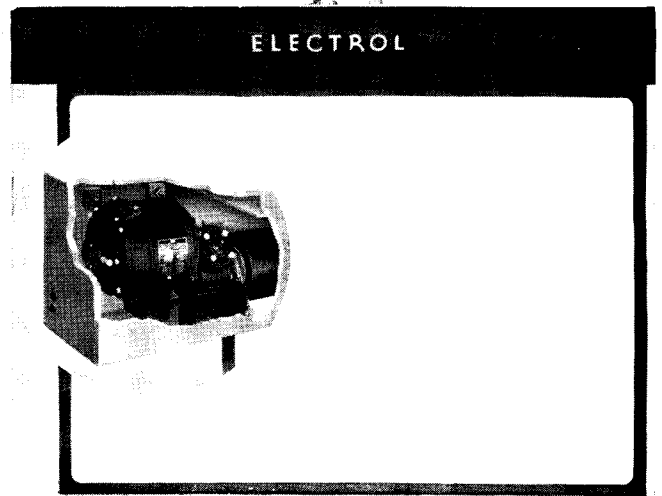
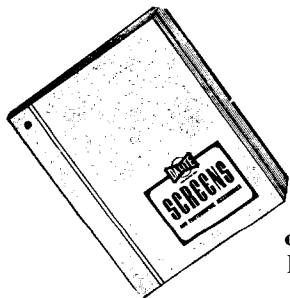

Da-Lite Glass-Beaded surface in 14 standard sizes up to and including 20'x20'.

The 48 page Da-Lite catalog fully describes the Electrol and other Da-Lite Screens, used in industry, schools and homes. You will find it a valuable reference book for the selection of screens for any requirement. Send for your free copy now.

**THE DA-LITE SCREEN COMPANY, INC.**

2723 NORTH CRAWFORD AVENUE • CHICAGO, ILLINOIS

mittee on Education, shows himself best qualified to receive it. Taken into consideration will be: the merits of his outline of proposed study; his background of academic and professional qualifications to pursue it; his promise of capacity; his character, ability, and purpose.

Application blanks and further details are obtainable from the office of the Secretary of the New York Chap-

ter, American Institute of Architects, 115 East 40th Street, New York City.

### Candidates Invited to Compete for Princeton Prize

GRADUATES of architectural schools, or draftsmen who have been employed in architects' offices for not less than three years, are invited to enter in competition for the 1940-1941 Princeton Prize in Architecture. Candidates

must be unmarried male citizens, not less than 21 nor more than 27 years of age on September 1, 1940.

The prize will be awarded on the basis of a competition in design to be held from April 18 to 29, 1940. Formal applications to enter must be filed not later than March 31. The winner will devote the following school year to the study of advanced architectural design and will have the opportunity of attending other University courses. In addition to being exempt from tuition fees, he will receive the sum of \$500 which will enable him to complete a year of residence in Princeton. He will, moreover, be entitled to all the privileges of a Fellow of the University, and will be expected to live in the Graduate College buildings.

Formal application blanks, complete details regarding eligibility, and regulations governing the competition and award may be obtained by prospective candidates from the Secretary of the School of Architecture, Princeton University, Princeton, N. J.

### New Addresses

THE RECORD publishes changed and new addresses only on request, making no attempt to keep a day-by-day account. The only organization in the country with facilities for doing this is Sweet's Catalog Service, whose painstakingly maintained list undergoes an average revision of 23 changes for every working day in the year. Below are the new addresses recently brought to our attention:

*Harry A. Fulton*, Architect, and *A. R. McCreary*, Engineer, have formed a full partnership under the firm name of Harry A. Fulton and A. R. McCreary, Architect and Engineer, with offices at 5716 Euclid Ave., Cleveland, Ohio. . . . *William F. Kussin* announces the removal of his architectural offices to 50 Beacon St., Boston, Mass. . . . *Otis and Lea*, Architects, (*W. Earle Otis* and *Elliott C. Lea*), are now located in Suite 312, Speed Building, 4th and Guthrie Sts., Louisville, Ky. . . . The new address of *Gorrell R. Stinson*, Architect, is P. O. Box No. 28, Elkin, N. C. . . . *Carl F. Strohmeier*, Architect, is now at 101 West 22 St., Baltimore, Md. . . . *Walter Dorwin Teague* has removed his offices to 444 Madison Ave., New York, N. Y. . . . *Thomas Lyon White* has opened an office for the practice of architecture at 445 South Warren St., Syracuse, N. Y. . . . *Gordon Wright*, Architect, and *Marjorie Wright*, De-

(Continued on page 116)



● Production heads and welfare men in thousands of the best plants in the country, consider their Bradley Group Wash Fixtures as important as their production equipment.

The fact alone that 56% of the 1939 output of Bradley Washfountains went to past users is itself proof of the water—, time—, and space-saving advantages provided.

You can modernize your wash-



Section of the Norton Co., Worcester, Mass., washroom

rooms and have these advantages, too. Each Washfountain serves up to 10 men simultaneously with clean running water—and requires 1/10 the piping installation, because one Washfountain serves as many men as 10 individual wash bowls.

### Write for Washroom Plan Book

To help you modernize, or lay out washrooms for new buildings, our "Plan Book" will be mailed on request. Write for a copy with names of plants in your locality equipped with Bradley Sanitary Group Wash Fixtures **BRADLEY WASHFOUNTAIN CO., 2227 W. Michigan St., Milwaukee, Wis.**



**BRADLEY**  
WASHFOUNTAINS and SHOWERS

The

# OVERHEAD DOOR

TRADE MARK  
WITH THE  
MIRACLE WEDGE



- ★ ADAPTABLE to all industrial and commercial jobs, large or small.
- ★ RELIABLE—works in any kind of weather. More than a million users.
- ★ WEATHERTIGHT — *wedges tightly YET opens easily.*
- ★ PRICED as low as a *good* door can be made.
- ★ SOLD INSTALLED—backed by a nation-wide sales-installation service.
- ★ UNIQUE — the door with the *Miracle Wedge* feature.

Built by  
**OVERHEAD DOOR CORPORATION**  
 Hartford City, Indiana  
 U. S. A.

**MAIL COUPON TODAY!**

Please send full information and free literature on doors for the purpose checked:

<input type="checkbox"/> Private Garage	<input type="checkbox"/> Greasing Station	<input type="checkbox"/> Hand Operated
<input type="checkbox"/> Public Garage	<input type="checkbox"/> Other Buildings	<input type="checkbox"/> Electric
<input type="checkbox"/> Warehouse	<input type="checkbox"/> Wood Sections	<input type="checkbox"/> Standard Model
<input type="checkbox"/> Factory	<input type="checkbox"/> Steel Sections	<input type="checkbox"/> Master Model

NAME \_\_\_\_\_

ADDRESS \_\_\_\_\_

CITY \_\_\_\_\_ STATE \_\_\_\_\_

signer, have relocated their offices at 315 E. Fayette St., Fayetteville, N. Y. . . . The following announce the removal of their offices to suite 711, Martin Building, Birmingham, Ala.: *James L. Galting*, Architect; *Henry Sprott Long*, Architect; *Lewis R. Paceley*, Associate; *E. W. Stanford*, Architect; *Jack B. Smith*, Architect; and *H. B. Wheelock*, Architect. This is in no way to be considered the formation of a partnership; each architect

will simply continue his individual practice in these new quarters.

**Necrology**

GEORGE STRAFFORD MILLS, 73, founder and senior member of Mills, Rhines, Bellman, and Nordhoff, Toledo architectural firm, died of a heart ailment on December 26 at his home in Toledo, Ohio.

Among the buildings remaining as testimony to his activity and skill as

a designer are: the Ohio Bank Building, the Edison Building, the Toledo Club, Ohio Bell Telephone Buildings throughout Ohio, the Commodore Perry Hotel, Safety Building, and the Willys-Overland Buildings, both in Toledo and other parts of the country.

After graduating from Washington University and studying architecture under *George I. Barnett*, St. Louis architect, Mr. Mills came to Toledo in 1885; he taught drawing in the Scott Manual Training School and afterwards became school superintendent. In 1912 he founded the architectural firm of which he was senior member.

Mr. Mills was elected a Fellow of the American Institute of Architects in 1915. He was also President of the State Board of Examiners for Architects, an honorary position which he held for many years.

ON JANUARY 1, a collision of two Illinois Central Railroad trains brought an untimely end to the architectural career of *Thomas E. Tallmadge*, since 1905 a member of the Chicago firm of Tallmadge and Watson. He was 63 years old.

A B.S. at M.I.T. in 1898 and an honorary M.A. at Northwestern in 1927, Mr. Tallmadge was known chiefly as an architect for ecclesiastical buildings. In 1918 he was Architect in Chief of Victory Loan decorations for Chicago. At various other times he was a lecturer on architectural history at the Chicago Art Institute, professor of architectural history at the Armour Institute of Technology, and President of the Summer School of Painting at Saugatuck, Mich. He was also author of "The Story of Architecture in America," wrote numerous brochures, and was co-editor of "Significance of the Fine Arts", published in 1921.

Mr. Tallmadge was made a Fellow of the American Institute of Architects in 1923. He was a member of several local and national art societies and commissions, and served as director of the Chicago Regional Planning Association. He was also a member of the Architectural Commission for Restoration of Williamsburg, Va.

AN ILLNESS of several weeks culminated regrettably on January 2 in the death of architect *Edward P. Casey* at

(Continued on page 118)



**IN DETROIT...it's Solder and Cotton!**

**IN JACKSONVILLE...Tobacco Dust!**

In your plant it may be lead dust, silica sand, papers or sawdust—or maybe just plain dirt that slows up production, injures the product, produces rejects and lost output. Probably even now it is costing you more to "clean" your plant than it would to really clean it with a Spencer Vacuum Cleaning System.

A survey of 440 plants using Spencer Vacuum on areas varying from a single department to a million square feet shows that it is universally used for walls, ceilings and pipes, as well as floors and that the cleaning is frequently done during working hours. In addition it is used to clean machinery, raw material, packages, finished goods, and to reclaim valuable scrap materials.

You can write a Spencer System off with its savings in two or three years. It is built to last a lifetime. Many of them have been in service for a quarter century.

**Write for this New Book on INDUSTRIAL CLEANING**

See how others clean large areas at low cost and save in production and maintenance because Spencer does the jobs that cannot be done by other methods.

ASK FOR BULLETIN 120-AR

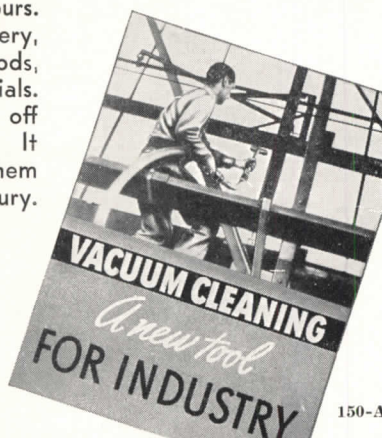

**SPENCER** CENTRAL AND PORTABLE  
HARTFORD VACUUM CLEANING SYSTEMS  
**THE SPENCER TURBINE COMPANY, HARTFORD, CONN.**



# SIMONDS 5 ACRES of SAW and STEEL Manufactured Weather

WORLD'S FIRST "Controlled Conditions" plant is this new home of Simonds Saw and Steel Company, Fitchburg, Mass. Designed by Austin Company, and completely air conditioned by Carrier, this modern 5-acre plant replaces 17 acres previously required.

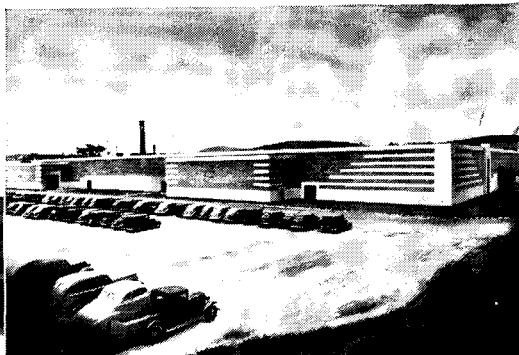

SINGLE ROOM includes every department . . . production, engineering and clerical. But, although 70 Forges and more than 1000 Grinding and Welding Machines are constantly in operation, Carrier conditioned air keeps workers cool and comfortable.



## 400,000 CFM of Temperature and Humidity Controlled Air for New Windowless Plant

• This windowless plant manufactures the proper weather for each department. The heat developed in the factory section presented its special problems in air conditioning. In the office and engineering locations, the efficiency of the workers required different comfort standards. But, Carrier equipment and technique brought the successful solution through Carrier's long,

world-wide experience in meeting the air conditioning requirements of industry.

Carrier engineers in principal manufacturing centers offer to management and operating executives its experience in meeting the air conditioning problems of industry for 33 years, in old or new buildings.

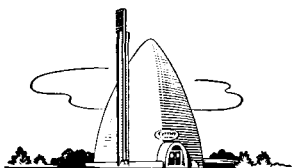

THIS SUMMER, visit the Carrier Igloo of Tomorrow at the New York World's Fair. 1930 is the 50th Anniversary of what is now Carrier Refrigeration, and the 25th Anniversary of the present Carrier organization.



CARRIER CORPORATION, DESK 9B  
"Weather Makers to the World"  
SYRACUSE, NEW YORK  
(In Canada, Box 1050, Station C, Toronto)

Send me information about Carrier Air Conditioning for:

- Processing Laboratories  Offices  
 Carrier Space Heating  
 Carrier Refrigeration

NAME.....

COMPANY.....

ADDRESS.....

New York City. Mr. Casey, designer of the New York State battle monuments at Antietam and Gettysburg, was 75 years of age.

In addition to his Civil War memorials, Mr. Casey was widely known for the buildings he designed in Washington, D. C., where from 1892 to 1897 he was architect for the completion of the Congressional Library. In 1900, with Professor *W. H. Burr* of Columbia University, he won first prize in

the design competition for the new Potomac Memorial Bridge, and two years later received the award for the Grant Monument in Washington. Also in Washington are his Memorial Continental Hall, Connecticut Avenue Viaduct, and the monument to Commodore Barry. Other buildings he designed include one for the American College at Beirut, Syria, and the United States Government Building at Sault Ste. Marie, Mich.

Mr. Casey took the degrees of Civil Engineer and Bachelor of Philosophy at Columbia in 1886 and 1888 respectively, and afterwards studied architecture for three years at the Ecole des Beaux Arts in Paris. He was elected Fellow of the American Institute of Architects in 1926, was at one time vice-president of the National Sculpture and the Beaux-Arts Societies, and was a member of various other cultural and social organizations, including the Architectural League of New York which he formerly served as treasurer.

ON JANUARY 11, at the age of 59, architect *Walter Mellor* died at his Philadelphia home. Senior member of the firm of Mellor and Meigs, he was known both in America and abroad as a designer of such buildings as the Bryn Mawr College auditorium, the U. S. Coast Guard Service memorial at Arlington, Va., and the chapel at Bony, France, and the monument at Ypres, both of which were undertaken for the American Battle Monuments Commission. Other buildings include various branch banks of the Philadelphia Saving Fund Society; Phi Gamma Delta Fraternity houses in Philadelphia, Pennsylvania State College, and Seattle; a Gymnasium for the Pennsylvania Institute for the Deaf; the Haverford College Science Laboratory; and many residences.

Mr. Mellor was a Fellow of the American Institute of Architects and a member of numerous other societies.

### Manufacturers' Publications

*Plywood Handbook of Residential Construction*, by Oscar Fisher and L. H. Meyer. Published by the United States Plywood Corporation, 616 West 46th Street, New York City.

In this 30 page brochure, the collaborators set forth the structural advantages and economies to be gained from use of "U S P" plywood, on the modular planning principle, in types of construction ranging from chicken coops to a \$5,000 house. Three houses—\$2,000, \$3,500, and \$5,000—are planned on the modular system, complete with outline specifications and budget of cost breakdowns. Other data and planning details, involving various "U S P" plywoods, are included on: closets, concrete forms, doors, in-

(Continued on page 120)



TYPE K FEATURES include patented full-floating relief of over-all expansion stresses, and "knee action" relief of differential expansion between individual tubes . . . spiral fins are pressure wound and metallically bonded on seamless copper tubes . . . entire surface is tinned for protection against corrosion . . . integral orifices and scale breakers . . . generously large cylindrical headers.

Husky, rigid ARMCO ZINCGRIP casings assure adequate protection against piping stresses and coil distortion. Casings are only 9" deep. They provide compact size, extreme strength, and long life, trouble-free service.

#### Catalogued in an Easy-to-Use Data Book

Fedders Type K Heating Coils are built in a complete range of sizes and capacities to fit your installation requirements . . . reserve your personal copy of Catalog H-601.

## FEDDERS MANUFACTURING COMPANY BUFFALO

Heating Division

Representatives in all Principal Cities

44 YEARS OF HEAT TRANSFER EXPERIENCE

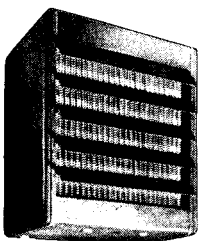

### FEDDERS UNIT HEATERS

Fedders handsome, sturdy cabinets . . . quiet operation . . . exclusive streamline tubes and non-clogging fins and approved by Heating Experts everywhere.

SEE HOW USG  
IS SELLING BETTER  
WALLS AND CEILINGS  
TO AMERICA



## We punched it full of holes, *to make a stronger wall*

WHEN we first started punching holes in Rocklath, the fireproof plaster base, some people found it hard to believe that holes would produce a stronger wall. But it's true!

Perforated Rocklath holds plaster in two grips instead of one—that's why it makes a stronger wall or ceiling. It's "riveted" because plaster is anchored through the holes in the Rocklath. It's "welded" because of the natural bond between the plaster and the Rocklath.

Walls and ceilings built with USG Perfo-

rated Rocklath and Red Top Plaster are smooth, durable surfaces. Rocklath does not warp, buckle or pull away from the plaster. It eliminates "lath streaks." Perforated Rocklath is *fireproof*. Tests show that a Perforated Rocklath partition, properly plastered, will hold fire at bay for at least one full hour!

Perforated Rocklath is an outstanding example of the application of research to home construction by the United States Gypsum Company. Like many materials developed

by USG, it gives homeowners better building, more fire protection and better walls and ceilings. Other important USG developments are resilient plastering systems, which reduce sound transmission between rooms and prevent cracks from frame movement.

USG materials are sold by leading lumber and building material dealers everywhere. Ask your dealer to secure for you USG's valuable books—"*How to Modernize and Make It Pay*"—and "*How to Have the Home You Want*"—or mail the coupon.

UNITED STATES GYPSUM COMPANY



*-where research develops better, safer building materials*

UNITED STATES GYPSUM COMPANY  
300

IN 1940 USG  
ADVERTISEMENTS WILL APPEAR IN

The Saturday Evening Post  
Better Homes & Gardens  
American Home  
House & Garden  
House Beautiful • Collier's  
Life • Good Housekeeping  
Woman's Home Companion

AR-2-40

# IN FACTORY BOILER ROOMS

# PETRO

## Saves space—fuel—labor—maintenance

Functional design for space-and-time economy in a new factory building, or to correct deficiencies in an old one, is most readily applied to the boiler when oil is used for fuel. Practically any industrial boiler can use oil.

The Architect can provide more factory production space from any given total area when fuel oil is used, because no surface space is needed for fuel storage, firing accessories, or waste handling. More boiler output is produced economically by the higher combustion efficiency of oil. Plant maintenance is reduced considerably.

These economies, inherent in oil firing, are multiplied into imposing savings when boiler room labor is eliminated by automatic burner operation.

### For efficient operation with pre-heated No. 6 (Bunker C) oil

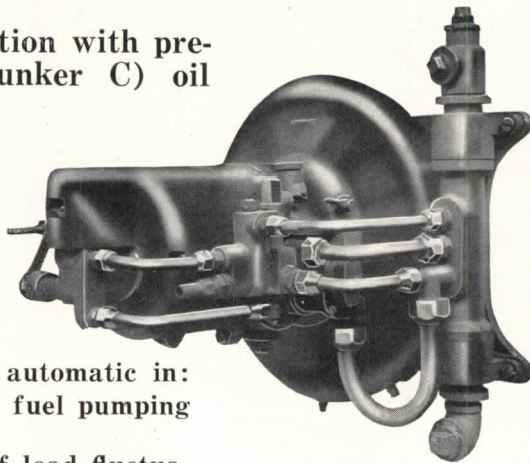

this Petro burner is automatic in:

- (a) "cold starts", (b) fuel pumping (integral pump);
- (c) instant meeting of load fluctuations, and
- (d) Literally and wholly automatic in controlling the supply of oil to the burner at flow-rate and temperature correct for maximum combustion efficiency.

*Petro Industrial Burners for Automatic operation are available in seven sizes, Models W2½ to W8 inclusive. Each burner is a self contained assembly of motor, fan, pump, rotary cup atomizer and interlocked air and oil adjustments. The illustration shows how soundly this burner is designed.*

**CAPACITIES: 11 to 100 gal. per hr.—27 to 336 boiler h.p.—4700 to 47,000 sq. ft. steam E.D.R.**

Maximum labor saving can be achieved only when the oil burner's operation includes all four of the automatic characteristics ("a" to "d") mentioned above. Burners which omit or improperly perform one or more of them, are obviously not automatic and fall short in labor cost saving.

The chemistry of oil and combustion proves that accurate viscosity control can be achieved only by applying controlled heat. Petro's Thermal Viscosity system is heat control—not orifices or mechanical measuring—and burns the heaviest pre-heated fuel oils at any fixed combustion efficiency without mechanical fire control devices (all of which require frequent manual adjustment). Petro automatic systems are wholly Automatic, not just partly so.

Semi-automatic and Manually controlled Model W burners and "Mechanical type" units are also available to meet circumstances which do not require automatic operation.

Petro's Engineering Division will gladly answer questions. The Petro Industrial Equipment Catalog will be sent promptly on request.

## PETROLEUM HEAT & POWER COMPANY

—Makers of good Oil Burning Equipment since 1903—

STAMFORD,

CONNECTICUT

## Manufacturers' Publications

(Continued from page 118)

sulation, interiors, sheathing, subflooring, sunsulation—to list but a few of the possible applications.

*H & H Wiring Devices, Catalog X.* Published by Hart & Hegeman Division, The Arrow-Hart & Hegeman Electric Co., Hartford, Conn.

The complete line of H & H wiring devices has been brought up-to-date in this 1940 Catalog, the 112 pages of which cover the electrical-wiring field exhaustively from pilot lights to candleabra sockets. In order to make this detailed information easily readable and assimilable, the manufacturers have chosen for their catalog a non-glare paper, which, combined with a special font of type in a superior off-set job, considerably facilitates the catalog's use by architects and specification writers.

*Only the Rich Can Afford Poor Windows.* Step-by-step analysis of window function and construction, with stop-slide suggestions on how to effect both immediate and long-range economies. Addressed to home owners as well as architects and contractors by the Anderson Corporation, Bayport, Minn.

*Thermal Insulation Manual.* Published by the Ehret Magnesia Manufacturing Co., Valley Forge, Pa.

260 pages of information, directed to everyone interested in choosing, applying, or using thermal insulations, are presented by Ehret in this latest manual, arranged in loose-leaf form to accommodate new and revised data sheets which will be furnished from time to time. Technical data include: Heat and cold insulations; accessories and fireproofing materials; recommendations and specifications; refractory cements; packings; building insulations and materials; asbestos fibers and textiles, etc. Also provided is a section giving useful general data and definitions.

*Livable Interiors for Warm Climates.* Information for architects, builders, and home owners who are called upon to combat excessive heat and moisture-condensation problems in the South and West; published by the Celotex Corporation, 919 North Michigan Ave., Chicago, Ill.