

# THE ARCHITECT IN SEARCH OF...

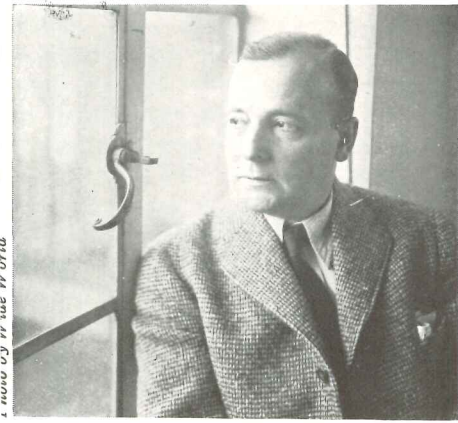

by FREDERICK J. KIESLER

We are introducing with this issue a new approach in architectural and art criticism. The interest of architects, generally, in fine and applied arts, including specifically painting, sculpture, stage design, the theater, furniture design, textiles, photography, is a result of both training and broad purposes of architecture. The exhibitions of our communities in art centers, museums, theaters, galleries and out-of-doors are found to be cultural classrooms for adult education. Exhibitions keep the public and, notably, the architect informed.

We have asked Mr. Frederick J. Kiesler,

architect, stage designer, to serve at our editorial desk as design critic. Through his many practical experiences abroad and in this country Mr. Kiesler seems to be especially well fitted as commentator on all forms of art so vitally important to a progressive and contemporary architecture.

Mr. Kiesler worked with Adolf Loos on the first slum-clearance projects for the city of Vienna. Since 1923 he has been an active member of the international architects group, "De Stijl." He was architect of the Theater Festival of the city of Vienna, 1924, where he built the first Space-Stage in Europe, since widely adopted in many countries. The Austrian Government nominated him director and architect of the architectural, theatrical and film exhibits at the World's Fair in Paris, 1925.

On his first visit to this country he designed a museum project for the Society Anonyme, 1927. He was later designer for Saks Fifth Avenue, New York City. During the last four years he has worked consistently in the industrial design field. He is a member of the faculty of the Juilliard Foundation.

Building Types—INDUSTRIAL BUILDINGS in this issue—was prepared by Stamo Papadaki who, before his selection for this special study, had participated in the design of a variety of industrial structures.

## MARCH . . . ENGLISH NUMBER

This issue, edited by Editors of The Architectural Review, London, has been in preparation over a period of several months. A plan was formulated about a year ago whereby the Editors of The Architectural Review, London, would edit one issue of The Record while The Record Editors would at the same time edit The Review.

The purpose of this exchange is to enable the respective editors to present the picture of architectural and collaborative design progress that is taking place in each country.

The English Issue of The Record will contain a résumé of recent advance made in British design. To do this special articles were prepared by outstanding English writers setting forth the background of English architecture followed by the development of changes within the profession and changes in the character of English design.

Tracing the changes in architecture in England up to the advent of the modern movement.

- THE ENGLISH SCENE. By Hugh Casson.
- PLANNING IN TOWN AND COUNTRY. By Thomas Sharp.
- THE ARCHITECT AND HIS PATRONS. By J. M. Richards.
- THE WORK OF THE ARCHITECT. By L. W. Thornton White.
- WHERE ENGLAND LOOKS TO AMERICA. By Herbert Read.

The portfolio of illustrations gives a review of what England is producing in planning towns, in housing, design of schools, industrial and commercial buildings.

The English Review is rated as the most brilliantly edited architectural magazine in England. It is likewise the finest in typographical appearance. This same skill in layout, in text and general appearance has been applied by our visiting Editors in producing the March Architectural Record.

ARTICLES IN THE MARCH ISSUE 1860 - 1930. By Nikolaus Pevsner.

## APRIL • MEXICAN NUMBER

Illustrations by Esther Born  
Arrangement by Ernest Born

MEXICO CITY has passed through a boom period of building. Schools, markets, office buildings, apartments, residences, workers' houses, airports, many of which are of extreme interest, have been built there during the past few years.

ESTHER BORN, whose photography work is

favorably known to architects and magazine editors, recently returned from Mexico with hundreds of views of the new architecture there. She also gathered comment by architects of that country on planning and design problems.

ERNEST BORN is producing page arrangements and drawings for this Mexican Issue in April.

## FORTHCOMING BUILDING TYPES

MARCH • HOUSING . . . . . APRIL • SCHOOLS

THE ARCHITECTURAL RECORD  
 VOLUME 81 • NUMBER 2 • FEBRUARY 1937



## CAPITAL TACKLES TWO TYPES OF HOUSING

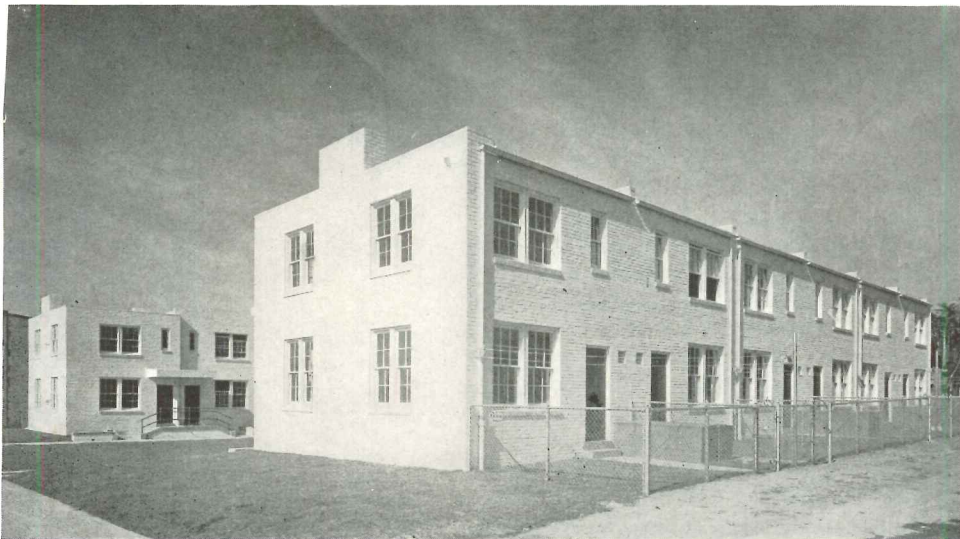

WASHINGTON'S ONE AND ONLY SLUM-CLEARANCE PROJECT IS HOPKINS PLACE, recently completed by the Dwelling Authority with WPA funds. Unlike most cities, where blight or slum conditions cover an entire area, the Capital is riddled by decrepit housing along the alleys which lace its blocks. Although modest in size—23 units—the Hopkins Place project demonstrates the possibility of rehabilitation of this condition.

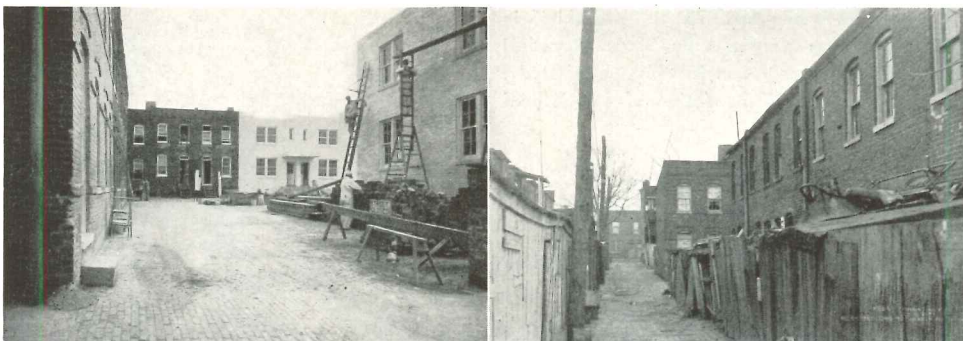

### Alley Dwellings Rehabilitated

Behind its classic marble facade, Washington has long concealed one of the nation's strangest slums—the inhabited alleys.\* And little, if any, of the millions recently lavished on the reconstruction of the Capital found its way into these areas. The Alley Dwelling Authority—set up, as its name implies, to alleviate this condition—has recently completed a small project to demonstrate ways and means by which these slums can be “cleared.”

Hopkins Place “was designed to provide the least expensive acceptable dwellings that are possible in the ‘old’ city” under existing laws: and to give the project the greatest demonstration value it included both reconditioned old dwellings and new structures. But the Authority hoped, by this project, to answer two basic questions: Is it

advisable from either or both the social and the economic points of view to recondition old dwellings of this kind, of which there are many hundreds in Washington? Is it advisable to erect new dwellings in the “old” city for the lowest income families? Detailed analysis of the project in terms of desired standards, planning and cost led to an affirmative decision.

Nucleus of the project were 2 rows of 11 alley dwellings in southeast Washington; acquired at the same time was some adjoining vacant land with a street frontage. On this were erected 2 rows of 6 houses each, bringing the total to 23 2-story, 4-room units. These are grouped around a U-shaped court open on the street; all have private rear yards. But a fairly wide variation both in size and accommodations was deliberately maintained. Six of the old houses were rebuilt to in-

\* Romantic legend has it that, during the Civil War, Northern sympathizers encouraged fugitive negro slaves to build on the rear of their lots; but this would hardly account for the prevalence of this type of housing in all the older portions of the

District. More likely it is that L'Enfant's grandiose plan—making no provisions for working-class housing and at the same time creating large irregular blocks which demanded alleys—created the condition itself.

clude complete bath, kitchen range and hot-water supply, while in the other 5 bath, range and hot water are omitted in favor of an outdoor toilet. Savings: \$183.20 or \$1.85 per month rent. All new units have baths, but one group has complete kitchen equipment while in the other only hot water is provided.

Rents in the Hopkins Place project run from a minimum of \$5 per room per month (in the reconditioned bathless houses) to \$7.19 in the completely equipped new units. They are naturally oversubscribed, but shortage of funds makes further work of this sort by the Authority uncertain.

### To House U. S. Officialdom

“To provide suitable living quarters in the City of Washington for members of the U. S. Congress, Federal Judiciary and Cabinet Officers,” Congressman Beiter (N. Y.) last month introduced a bill for a \$6,000,000 housing project. Startling in its directness, the bill calls for a development “wherein the full and proper degree of privacy will be provided for 600 members of Uncle Sam’s legislature, judiciary and executive branches.

According to the Beiter Bill, “Congress Corporation” will be set up under Delaware laws, empowered to borrow not more than \$6,000,000 from RFC. It shall acquire a suitable plot of ground, near the Capitol and House and Senate Offices, at a price not to exceed \$1,500,000—this plot to be protected by a 600-foot belt of properly zoned property. On this plot the Corporation is to erect a structure containing at least 600 units comprising “not less than a large living room, bedroom and bath. The height of buildings shall be a height limit of two hundred feet above the present grade, no including flagpoles or wireless towers. The type of building design shall represent the best obtainable in architecture and engineering. Furnishing and equipment shall be of a kind, character and quality that will best serve the purposes of this Act.”

The capital stock of the Corporation is to be divided into 600 shares of no par value, one share to be held in trust by each Congressman, member of the Federal Judiciary, and Cabinet, president and vice-president. These stockholders have full powers on the Corporation Board while in office, the stock passing to their successors. They are to levy from all tenants an annual surcharge to cover interest, amortization, etc.



# U.S. HOUSING STILL NO BED OF ROSES

## Steel Town Touts Steel Houses

From four-room cottages to a two-story house with porcelain enameled exterior, Middletown, Ohio, has 24 steel residences—"to say nothing of numerous service stations and other steel buildings"—and workmen are putting finishing touches on six more. Two local companies—Steel Buildings, Inc., and The Insulated Steel Construction Company—are producing these self-framing steel houses for approximately the cost of conventional construction.

"Various investigators state that the number of residential units that should be built is from 400,000 to 750,000 annually for the next ten years," said Charles R. Hook, Armco president. "There is no doubt in my mind that . . . the solution lies in the mass production of houses with its resulting lowering of cost and increase of employment."

## PWA Achieves \$4 p. r. p. m.

Preparing to open two more projects on PWA's national program of slum clearance and low-rent housing, Harold L. Ickes recently fixed rents for William B. Paterson Courts in Montgomery, Alabama, and Liberty Square in Miami, Florida. Under the George-Healey Act, which governs the renting of Housing Division projects, tenancy is restricted to families of established low income, not exceeding five times the rent and utility charges (utility charges for heat, light and cooking will be paid by tenants). Rents will average around \$4-\$4.50 per room per month.

According to surveys just completed in connection with William B. Paterson Courts, there are 5,940 self-sustaining negro families in Montgomery who live in housing which is not decent, safe or sanitary. Close to 2,000 of these will be eligible, on the score of income at least, to become tenants of the new community, but only 156 units are available. Some idea of accommodations now available may be found in the disclosure made by the survey, that there are apparently only 300 negro rental units in the city equipped with such elementary facilities as private water-closets.

## Charity Demands Housing

As discussion over New York's Multiple Dwelling Law reached a crescendo

before it went into effect last January 1, Manhattan's old and august Charity Organization Society went into action. At hearings on the Law, Sydney Maslen, chairman of the Society's Tenement House Committee, submitted a report which proposed that: legislation be enacted requiring the "demolition or complete renovation of uninhabitable buildings"; that the city rehouse at the same rentals all families whose homes are vacated or demolished; that the city itself recondition and manage all "boarded-up" tenements and make a survey of tax-delinquent properties suitable for housing "with a view to utilizing them for providing decent low-rent housing, primarily for displaced low-income families."

## NPHC Holds Fourth Housing Conference

Held last month in Washington was the Fourth Annual Conference of the National Public Housing Conference. NPHC delegates first drank tea with Mrs. Eleanor Patterson, publisher of the *Washington Herald*, heard Mrs. Franklin D. Roosevelt. Subsequent discussions were "Subsidies for a Nationwide Housing Program," "Price Value and Acquisition of Land," "The Worker as Builder and Tenant," "Organizing the Public Demand for Public Housing." The Conference closed with a bus tour of Greenbelt (Tugwelltown), Maryland, RA's subsistence project on the Capital's outskirts.

## NHA Folds Up

With the close of 1936 the National Housing Association, after 27 years of active work in the national field, has decided to discontinue its activities and disband as a national organization, according to a recent report.

"The situation which led to the establishment of the Association 27 years ago no longer exists. At that time there were no national organizations dealing with the problem—in fact, few local ones outside of New York City. Today, that is not the situation. The pioneer educational work in this field has been done. There are now a number of national organizations and many local ones and numerous Governmental agencies dealing with housing, the latter with vast funds available."



STEEL HOUSES ARE NOTHING NEW TO home owners of the Ohio steel center of Middletown. Here are four built several years ago and right across the street six more are in the process of erection.

Wide World Photo



WITH SLOW BUT CERTAIN TREAD, PWA's housing projects near the finish line. Seen above is Jane Addams Houses, rehabilitating a small sector of Chicago's notorious West Side. The project was named for the late Jane Addams, of "Hull House" fame, one of the nation's foremost social workers and life-long advocate of better housing for the American people.

## LOW RENTS IN THE SOUTH

### WILLIAM B. PATERSON COURTS

Unit	Average Weekly Rent
2 rooms	\$2.00
3 rooms	2.80
4 rooms	3.60
5 rooms	4.50

### LIBERTY SQUARE

Unit	Rent per Week	Average
2 rooms	\$2.85	\$2.85
3 rooms	3.70 - \$3.85	3.73
4 rooms	4.25 - 4.75	4.46
5 rooms	5.25	5.25



## THESE MADE THE HEADLINES

Globe Photo



**LONDON** A new inn just opened outside London. Called "The Comet," in memory of the plane which won the Melbourne Air Race, the aerial motive runs throughout the architecture, the whole building being designed in the shape of an airplane. The sign is a 15-foot stone pylon topped by a model of the "Comet."



**KENTUCKY** In the blue grass near Lexington this clubhouse and grandstand was recently opened in conjunction with a new race track. Although the "Derby" is held at Louisville, the breeding and stud farms center here; with these luxurious accommodations Lexington can now bid for big-time events.



**PARIS** To beat the flooding Seine, foundation plans for the United States Pavilion were last month radioed to the Paris Fair. First commercial application of the transoceanic radio facsimile, the transmission took less than an hour. While many distinguished visitors at R.C.A.'s Manhattan office looked on, the 8" x 10" plans were wrapped onto a slowly revolving drum. As the drum revolved a small lamp scanned the surface, creating electrical impulses corresponding to the lines and figures of the drawing indicating the location of piles and walls of the building.

Wires conveyed the electrical impulses to a powerful transoceanic transmitter on Long Island. Near London, a receiver attuned to the American wave, and a facsimile recording machine, reversed the New York process and reproduced the plan on a film, which was then developed, printed and sent to Paris.

The designers of the United States Pavilion, Wiener, Higgins and Levi, explained that while the foundation work is in progress on the Quai d'Orsay, the building proper would be in process of prefabrication in this country and ready for assembly in the French capital immediately the flood waters have subsided.



**PACIFIC OCEAN** Where this modern hotel now stands, "gooney" birds once played undisturbed; Midway Island in the South Pacific, now one of the overnight stops in the new airline to the orient. Almost overnight this desert islet was converted into a modern self-contained community with hotel, complete staff quarters, radio and meteorological station.

Globe Photo

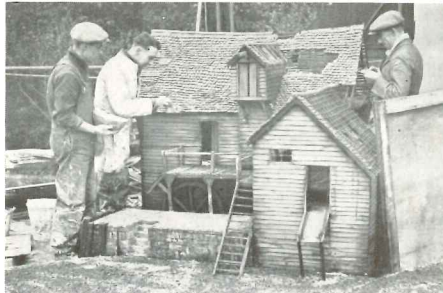

**ENGLAND** Workmen putting the finishing touches on "The Mill on the Floss." This model, along with many others, will be washed away in a Lilliputian flood during the filming of the famous novel of the same name.

Wide World Photo

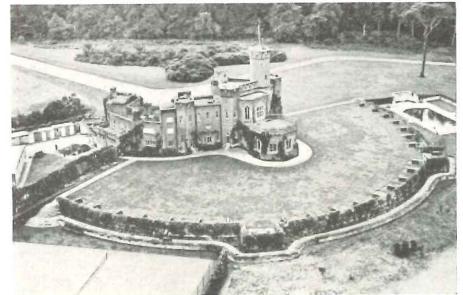

**FORT BELVEDERE** The gardens that rocked the British Empire; seen from the air, the pool and tennis courts which Mrs. Simpson helped the former King install wear a neglected air. Here it was that Edward made his famous choice. With both parties now in exile, Fort Belvedere is now rumored to be for sale.



**SCHENECTADY** This new home for WGY, with the latest studio and control-room equipment, will shortly be built. The new structure, two stories in height, will contain five studios; it will be stone finish with glass blocks.



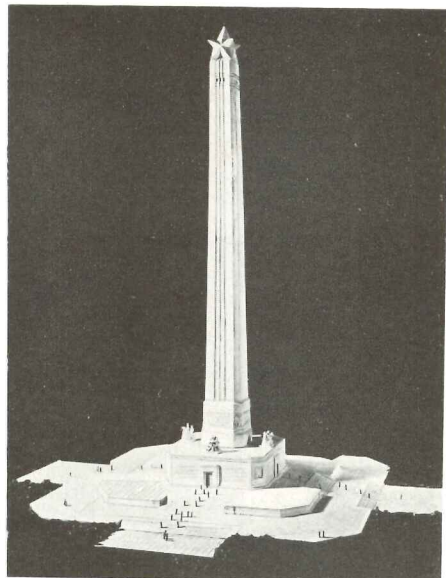

TO COMMEMORATE THE VICTORY WHICH made Texas free, this shaft will rise 565 feet in the San Jacinto Battlefield. Its base contains a museum, an art gallery, an auditorium seating 5,000; elevators will make the trip to the top an easy matter for visitors.

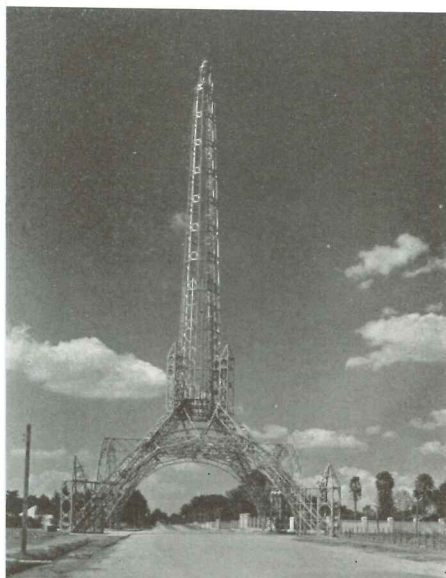

TO COMMEMORATE A DEAD DICTATOR, General Justo Barrios, Guatemala recently raised this memorial in the suburbs of the capital city. Originally conceived in limestone, savvy American engineers were able to point out that steel would be far safer than stone in this earthquake-ridden country. They got the contract.

**Princeton Announces Fellowship, Prizes**

Princeton's School of Architecture announces the annual award of the Lowell M. Palmer Fellowship for advanced study of architecture. The holder is exempt from tuition fees, and may receive in addition a cash award from the Lowell M. Palmer Fund sufficient to enable him to complete a year of residence at Princeton.

To receive consideration for appointment for 1937-38, applications, together with supporting documents, must be received not later than March 15, 1937. Application blanks from School of Architecture, Princeton University, Princeton, New Jersey.

Also, two competitive prizes of \$500 each, in the School of Architecture, are announced for the year 1937-38. The purpose of these prizes is to permit men of unusual ability to complete their professional training. The prizes will be awarded as the result of a competition in design to be held from 9.00 a.m. April 16 to 9.00 a.m. April 26, 1937. The winners are exempt from tuition fees.

Candidates for these prizes shall be unmarried male citizens, not less than twenty-one nor more than twenty-seven years of age on September 1, 1937, who have been employed as draftsmen in architects' offices for not less than three years, or who have otherwise demonstrated their ability in architectural design. Applications must be filed on or before March 15, 1937; further information from Professor M. L. Beck, McCormick Hall, Princeton, New Jersey.

**Rotch Travelling Scholarship**

The Rotch Travelling Scholarship will this year be awarded for a term of not less than 15 months of study and travel abroad, the amount of the prize being \$2,500 payable quarterly beginning October 1.

Examination of candidates will be held early in April, but candidates must register before March 1, 1937, and must fill out application blanks which will be furnished on request. The Committee of the Boston Society of Architects will make personal investigation of all applicants; right is reserved to determine after personal appearance before the Committee whether or not such candidates are qualified. Further details from C. H. Blackall, Secretary, 31 West Street, Boston, Mass.

**For Better Wall Papers**

United Wall Paper, Inc., is sponsoring a wall paper design competition. First prize is \$1,000, and there will be an indeterminate number (not fewer than three and not more than ten) of \$100 prizes. Awards will be made March 10, 1937. Designs must be received by United Wall Paper Factories, Inc., Jersey City, N. J., not later than 5 P.M., February 27.

**Pratt Alumni To Organize**

The Art Alumni Association of Brooklyn's Pratt Institute will hold its First Annual Convention at the Waldorf-Astoria, New York City, February 12 and 13. Increasing demand for a modern and efficient art association was influential in bringing about the organization of this group, which will provide for the exchange of ideas necessary for keeping abreast with the rapidly changing conditions in the field.

**FAECT School Begins Spring Term**

Registration for classes in architecture, engineering, chemistry and mathematics, as well as cultural subjects continues at FAECT's school in New York City. A special course is offered for preparation for professional license exams. No prerequisites are required, other than "familiarity with the subject gained by work in the field." Further information from FAECT School, 114 East 16 Street, N. Y. C.

**CALENDAR OF EXHIBITIONS AND EVENTS**

- **February 1**—Prints and Drawings of Architecture, Galleries K 37-40, Metropolitan Museum of Art, New York City.
- **February 12, 13**—First Annual Convention of The Art Alumni Association of Pratt Institute. Waldorf-Astoria Hotel, New York City.
- **February 13**—Opening, Spring Term, School of Architecture and Allied Arts, New York University, New York City.
- **February 17-19**—Electrical Industry Exhibition, Masonic Temple, Detroit, Mich.
- **February 21**—(Not later than 5 P.M.) Closing date for designs in competition sponsored by United Wall Paper Factories, Inc., Jersey City, N. J.
- **March 1**—Closing date for registering Rotch Travelling Scholarship. Information from C. H. Blackall, Secretary, 31 West Street, Boston, Mass.
- **March 15**—Closing date for applications. Lowell M. Palmer Fellowship, School of Architecture, Princeton University, Princeton, N. J.
- **March 15-19**—National Oil Burning and Air Conditioning Exposition, Philadelphia, Pa.
- **July 17**—Opening, XIV International Congress of Architects, Paris, France.





BUDDHA STATUE of the seventh century A.D. standing one hundred and seventy feet above ground in the BAMIAN VALLEY, AFGHANISTAN. The niches in the are shrines or dwellings of priests. *From the French film, THE YELLOW CRU*  
text pag



# THE ARCHITECT IN SEARCH OF . . .

## design correlation

a column on exhibits, the theater and the cinema

By FREDERICK J. KIESLER

### art, Art, ART

Trapped by the Federal Art Project of the Works Progress Administration (WPA) in association with TRAP (Treasury Relief Art Projects), approximately 5,300 Fine-Art-Artists have produced art-works. Samples exhibited recently at the Museum of Modern Art and at the Whitney Museum offered two critical evaluations: the discovery of new talent, and the interrelation of architecture and the fine arts.

Note immediately Point I: critic-skipped artist Number One in the catalog of the Whitney Museum—Bertrand R. (R missing in official catalog) Adams. An unknown artist, best, in my opinion, in his mural for the Dubuque, Iowa, post-office. His self-written biography (thanks to special service of Washington's TRAP director) follows: "Born, Webster City, Iowa, November 29, 1907. Began art career, studying taxidermy with local taxidermist. Found out how robins hop and chickens walk . . . and never vice versa. 1925 seriously began art pursuit by enrolling in a commercial art correspondence course. 1928 entered University of Iowa. Majored in both art and economics." Certainly a practical American approach to the life artistic. "1934, after five years of college, began work in Iowa State College Library—murals, under PWAP. Hobby—book-plate collecting and etching. Recreation—farming." Judged by the display of his talented accomplishments, a foundation of taxidermy—followed by a correspondence course in art—with economics and farming as recreations—are hereby strongly recommended to all art-aspirants.

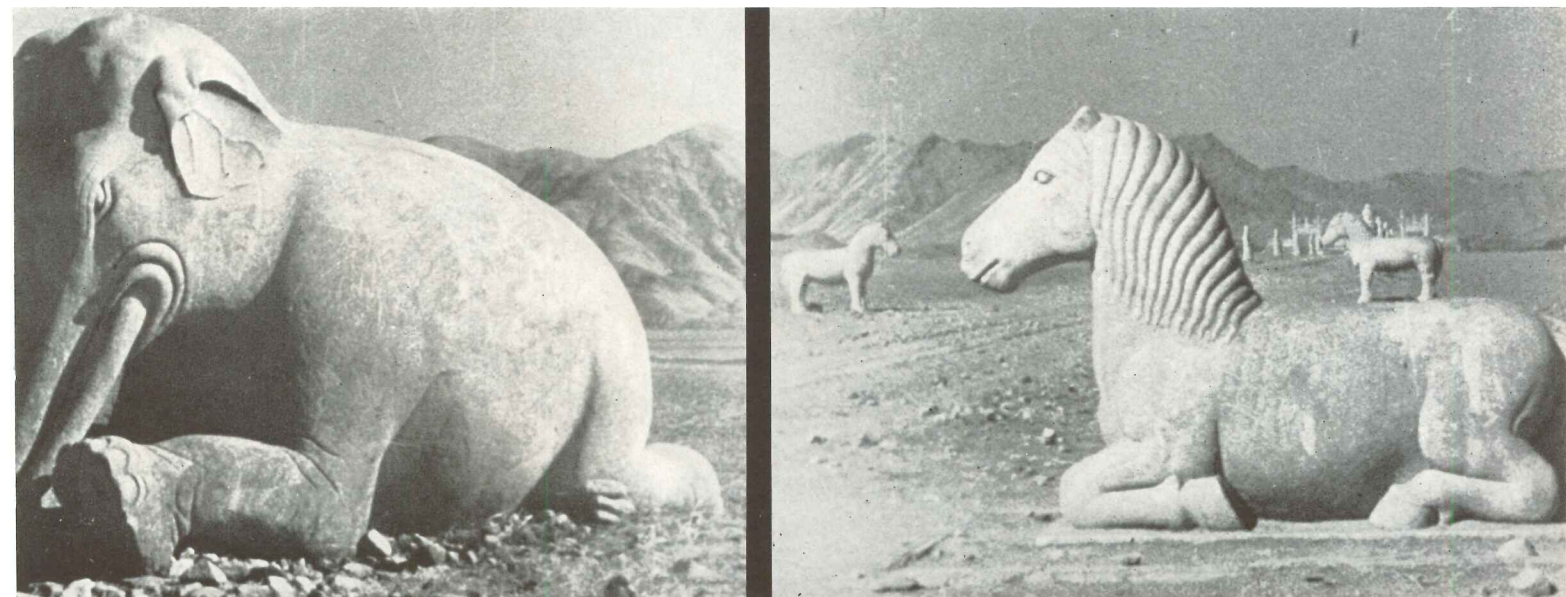

Photographs courtesy French Motion Picture Corp.



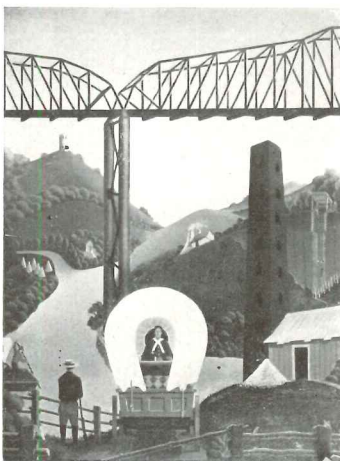
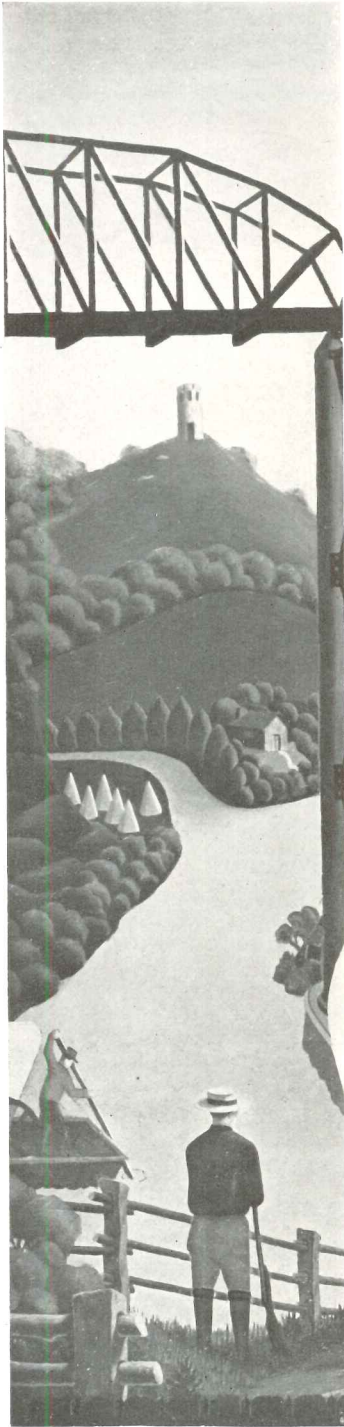

Courtesy Whitney Museum

The presentation of the Federal Government's paintings and sculptures at the hospitable Museum of Modern Art unmistakably displayed the high average capacity of its "relief" artists. Interesting is to observe the crystallization of a national style in painting and sculpture in any country: more so in the U. S. A. Up to now fine-art-production in this country reflected only a cross-section of old and oldest, as well as new "foreign" Museum-Masters, as indeed the population itself is a human amalgam of almost all un-American nations. Best samples of an American trend in painting **now** emerging consciously from this international conglomerate of art-influences were furnished by two Art-Workers: Louis Gugliemi, with his "Wedding in South Street," and Gregorio Prestopino, with his "Green Mountain Village." Both painters were unknown to the general Art-Public before this exhibition, including dealers, critics and other voyeurs, snobs, art lovers and bystanders. Holger Cahill, Federal Art Director, earliest early American folk-art searcher, has thus justified the title of his exposition "New Horizons in American Art." Of course, considering the vastness of the plains of the U. S. A. these horizons are quite far away, but on a clear day a good binocular will see them.

What are the objectives by which art, nationally defined, can be measured? It seems such art-work will **first** need to be examined for: its geographic authenticity (birthplace of the artist, his residence); **second**: the locale of his subject; **third**: the method of treatment (aim, composition); **fourth**, most important: his technique. The further we advance in these four points, the more difficult becomes artistic identification; and the last point (the technique) is the most intricate of all because of its very sublimation of the artist's creativeness. The stronger the artist, the more definitely will he arrive at his own technique of interpretation. Still, it is amazing that his individuality will not be seen "at once," although later, by repeated acclaim, it will be pointed at by guides, like Grant's Tomb, or La Tour Eiffel.\* Searching the American art field with these four beams of identification, what do we find? Measured by this arbitrary standard, we are compelled to deduce that the two above-mentioned works are chiefly distinguished: by the artist's poignant preoccupation with smooth detail, a true trace of "early art" in any country, and further: by a general expression of loneliness almost amounting to despair, or, as in the picture of Bertrand R. Adams, a loneliness self-sufficient in its social romanticism. As if American artists, influenced by the functional tidiness of a highly mechanized culture, had a definite predisposition towards technical neatness and clean-cut effects in their work. The total impression is one of overwhelming, sanitary bleakness—of almost arctic **isolation**. Perhaps this quality is a good enough test of their creative integrity in a country where their special aptitudes have been overshadowed by a mass-psychosis of commercial fixations. Their work indicates a three-way direction: **social romanticism** (picture 1), **social criticism** (picture 2), and **glorification of technic** (picture 3).

"Wedding in South Street" is, aside from all "artistic" qualities, a deep denunciation of social conditions. The diminuity of the human and his personal affairs in comparison to matter-of-fact business-structures-and-monuments is almost documentary. Slum-houses ornated with Greek columns, but nevertheless "to let," are a fine criticism of our multiple-dwelling laws.

\* Some paintings are difficult to interpret, if one insists on national demarcation. Whistler was American born of Irish extraction, but his pictorial expression spiritually and technically is typically English Matthias Gruenewald, German-born, resided during his lifetime on the German side of the Rhein (Frankfurt, Mainz, Aschaffenburg), close enough to France to be strongly influenced by French culture; a fact that makes his work entirely different from any "Germanic" art.



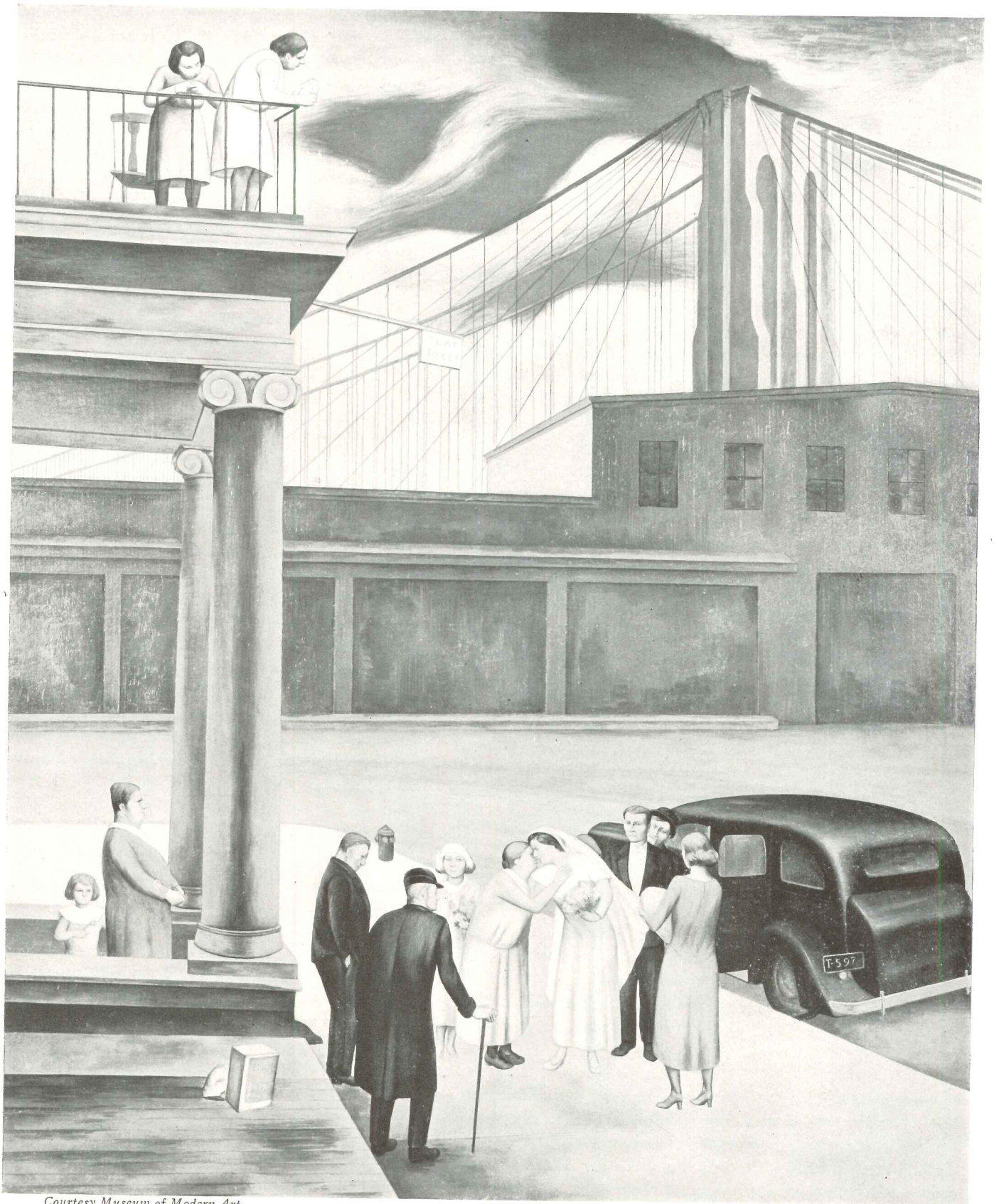

Courtesy Museum of Modern Art



## between murals without walls and walls without murals

Point number two: regarding the interrelation of architecture and the fine arts—there is interesting news for the outsider. "The Treasury Department has become one of the greatest, if not the greatest, architectural client in the world." We are quoting from the catalog of the exhibition. "The association of the Treasury with art goes back to the earliest days of our history, since it was to the Treasury that Washington himself gave the command of Federal architecture. Although today there is a Capitol architect's office, which has supervision over the Capitol, the House and the Senate office building and the Library of Congress, and, although various technical structures, such as fortresses and naval bases, are designed and constructed by their own departments, the greater part of Federal architecture comes under the aegis of the Treasury Department." (No sketches were exhibited for possible decoration of fortresses, although loneliness engendered by waiting for an enemy might well be mitigated by dioramic paintings.) "The vast expansion of the country has greatly increased the need for Federal buildings, which include post offices, courthouses, mints, buildings for the Customs, Immigration and Coast Guard services, and general office buildings. In short, the Treasury Department, having had as one of its traditional duties the supervision of federal architecture, has now taken over the **educational and aesthetic work** of adding distinction to its architecture, by means of painting and sculpture." Certainly **a matter of vital concern** to every practicing artist and architect in the country, and one which compels him to take a creatively decisive attitude. "This cooperation between the three great Arts is what gives the program its essential character of permanence and **its social and educational force.**" Important, that this new authorization to coordinate public, painting, sculpture and architecture is again inaugurated by a great public agency, as has already been done in past centuries, excepting that today it is perpetrated on an enormous scale. Selection of suitable decorating artists, such as painters, sculptors and industrial designers, is based on national competitions, but the choice of qualified architects for these buildings is NOT determined by any test which would demonstrate equal competence, meaning: artistic integration. We quote again: "In each case employment is limited to professional artists capable of meeting the standards established by the Supervising Architect's Office for the decoration of Federal Buildings."

**co-constructors** If I read correctly, it says: standards established by the Supervising Architect's Office. Do these standards mean: the un-American cross-breedings of Romanic, Gothic, Greek, modernistic columns—archway and window—orders, to which the prize-treasury-winners have to interrelate their mural designs and sculptures? The objection listed here does not concern itself with imitations of classical murals within re-created classical architecture: criticism of such affinity is superfluous. The objection concerns only modern murals within a framework of classical or semi-classical architecture. **They can not integrate.** They can not balance to unity. One of the two must submit against will to numbness. Both will finally degenerate. Does it mean that **contemporary** talents

have to furnish a living vitality for these pathetic architectural ghost-brides of the **past**? Would it not be practical to establish new commandments for creative integration for the Supervising Architect's Office, of this, the world's greatest client, and establish **standards underwritten by sculptors and painters and industrial designers**, whose status has already been demonstrated by successful emergence from a nation-wide competition? Or shall we continue to accept the artistic standards of the Supervising Architect's Office—for the Supervising Architect himself and in addition to that: for all private artists? Is this proposition not too one-sided? Is not the artist under such architectural circumstances merely an employee measured by wall-footage, while in reality he is a creator and as a muralist certainly a co-constructor? Of course, we understand that the government agencies have to relieve the sudden impact of building problems with means immediately at their disposal and are therefore handicapped in their best intentions. And any solution depending on a new interaction of governmental laws, traditions, routines and so forth, and temperaments of artists and technicians, needs time to grow—but consider the predicament of the contemporary American muralists. Functioning as they do within the ancient framework of outmoded architectural concepts, they are prevented from approaching their **present-day problems** with a proper regard for the paramount element: Time. In short, **1: what is the life span of the building structure, specifically of the wall? 2: what is the technological aspect of paint and its durability? 3: what is the time-gauge by which the public is expected to view the mural and absorb its meaning? 4: provision of controlled artificial and natural light-intensities necessitated for clear vision of murals according to distance from observers, stopping or in motion, and in relation to the proportions of the design as a whole and in detail.** The answers to these basic questions ought to be the chief technological considerations of the muralist and of the architect, no matter what message is to be delivered. Actually, not only the architects but the mural painters too are completely out of step with the current time-structure.

**muralizing** What is their general paint-procedure? The brush filled with watery paint is set right **into** the wall; this is genuine mural painting. The brush with creamy paint set on canvas or wood or glass or any material which is hung **in front** of a wall, is easel painting. If this is right, many of the modern paintings called mural paintings are not mural paintings but easel paintings muralized by pasting a painted canvas on the wall. Mosaic seems to have been an industrialized genuine mural painting of the past, so here is a very early sample of industrialized handicraft in the field of fine arts. Many painters might object to being called handicraftsmen because they feel as though they were aristocrats of the order of fine arts. The public, of course, is not interested in how the painting is painted, mural or easel; it is interested in the effect, in the message of the work (or not even in that). But craftsmen and technicians know that the technique of a work is its final expression. In that span which consists of the tiny space between the material a painting is painted on and in the final surface-epidermis of the paint lies the story of the mastership of its creator. It is in genuine mural painting, the **micro-minutest**



space (Giotto's frescos), and in easel-oil-painting, the **micro-mightiest** one (Rembrandt's later pictures). And that because the mural painting *buono al fresco* sucks the painting into the wet wall ground and interbinds it with the building structure while swallowing it. If your hand glides over the mural painting, you do not feel it, but the roughness of the wall itself; your skin gliding over an oil painting feels the bulk of paint and stroke. This transparency of watery al fresco painting was one of the great attractions for the painter and architect and they definitely played with the wall ground as to color and texture which glowed through the paint into the eye of the observer. That sensitive texture-technical feeling of a mural painter is too inherent with the talent of such a craftsman to have been lost at any time anywhere in these centuries, but it seems natural also that in certain periods this sense might have remained undeveloped or restrained in its exercise. Of course, in regard to mural painting, there is not only the sensitivity of the painter—a deciding factor—but the **environment-elements** too, the architectural structure that underlies his paint and composition, and the building as a frame coordinating his own composition into a "heterogeneous unity." An easel painter **has** the control of the unity and finality of his work in his own mind and hand, **not** so the mural painter. Even the coordination of the easel painting to a wall is in the hand of the easel painter by his designing and choosing of a frame for his strictly bound composition. This frame of wood, carved or plain, colored or natural, is the independent intermediate between his painting, a very personal expression, and the surrounding wall of a room, a general and super-personal background.

**vis major or vice major?** The question is, can you detach the quality of a work from its technique? I am inclined to say: No. Of course, any artist of quality will express this quality in every medium but, and that is the crux, he will use each medium rightly. If somebody paints a mural painting on canvas in oil paint (as in the case of Gorky's mural for the Newark airport), he is either revolutionary, an amateur, or one who is prevented by **vis major**\* from doing what he thinks is right to do; for instance, the lack of material, the lack of proper wall preparation, the shortness of time, or the necessity for a "**mobile**" mural painting detachable from a salvaging point of view, due to shortlived building structure as a whole.

**Successive painting and pre-prepared paintings** The fresco technique, which many of the modern muralists employ, belongs to the past of highly individualistic periods, dictatorial or monarchistic, as in Asia, Central America and Europe. To paint, to prepare foot by foot the material for "successive paintings," is anachronistic. **Technically it belongs to the stone and plaster age!** Objectivity of optical mural language, as propagated by revolutionary artists (with the exception of the Mexican Sequeiros), is directly opposed to this old fresco-technique. By their paint-technique, they propagate high individualism, but socially they propagate collectivism. A fresco of this kind is untimely for the extreme mobility of contemporary life: it is too long-lived for us—and too short-

\*In law, a superior force which . . . is held to exempt from contract obligations.

lived for posterity! Further: the mural painters of the past labored in the certainty that their works were displayed in buildings where people gathered in silence and meditation (mainly in churches). It was eminently appropriate to speak to them by means of static pictures, their language of communication. This had a logical influence on the design and color schemes and conditioned their choice of suitable materials for walls and paint. Today, almost all modern muralists have been influenced by the Mexican school which uses the illustrative method to the point of overcrowding. And, although they abandoned the pure decorative elements of the nineteenth century murals, they have fallen into the other extreme of shouting a hundred clamorous messages from painfully overburdened walls, which no contemporary can absorb at once. Mexican artists, fully aware of this incongruousness between thought and technique, but hampered by a lack of choice in a land of small industries, are compelled to continue their expressions with ancient media. But the U. S. A. designers have no such excuse to offer. They could, and ought, to attempt a contemporary mural-technique! A powerful optical challenge for the preoccupied and speeding spectators who pass through public buildings. Light steel frames, for instance, covered with enameled metal in a hardened porcelain process—easily removed and yet durable—might help the evolution of a new concept on the part of the muralist: industrialized murals. There are too many unexplored technological possibilities to be accounted for here, but certainly the use of graffito, fresco and oil painted canvas in a time which is so rich in new technical expressions shows an amazing sluggishness on the part of our much touted native ingenuity. Do we want the murals **to endure** or do we want the murals **to perish** within five years or fifty, through their own demerits, through building-wreckers, through both, or none? Do we want the designed message to be readable, or do we want just pay for a job? We have to make up our minds about it. The result of that decision will help distinctly to decide the composition-technique of the mural and the building materials and the design of the structure as a whole. Not a single attempt at a contemporary technological approach to this problem was displayed either at the Museum of Modern Art or at the Whitney Museum. Nor were any signs of such an attack exhibited at the Museum of Modern Art Mural show in 1932.

**a heterogeneous unity** The architect of today is again, after a pause of twenty-five years, at work to coordinate such strange parts as painting, sculpture, industrial furnishings, and building structure into a heterogeneous unity, called Architecture. For such a problem the modern architect has **not been trained**, since it belongs to a tradition which was both willingly and unwillingly lost. This breathing-spell from décor in building-structure has set our minds free and has given industry a chance for inventing additional techniques of reproduction. (The Art-creating-machine has not yet been invented.) Already today, any building surface, flat or curved, with any texture, rough or smooth, can be sensitized and the mural-image then projected on an emulsioned ground by any ordinary photo-projector. It is then developed like a photographic print and by means of spraying the picture is permanently fixed. It is washable



and, if so desired, can be removed by chemical means. This is a new way of mural painting.\*

Summing up: the old way of mural painting is **fresco**. A newer technique, very frequently employed by Federal WPA artists, is oil-painted-canvas pasted on a wall which might be called **murals without walls**, because the painting is not merged with the wall surface, as in fresco. The new process of sensitizing walls gives us not the common **photo murals**, but **projected murals**: walls transformed into pictures by means of light.

Strangely enough, all modern European architects pleaded for **walls without murals**. In this Europe still persists. The U. S. A. relief projects have, however, put to rout all European arch-art-attitudes and have "ordered" murals, no matter what technique, no matter what architectural surroundings, as long as they were allocated to public buildings.

The question at present arises: if the muralist will be dropped from his scaffold by the government restricting or closing the WPA, will it mean that he will be dead and that contemporary architecture will drop back to walls without murals? Or will the "Federal art-technique" be taken over by private enterprise, the muralist kept artificially alive as long as their funds last? Or will a new technique of pictorial, sculptural and structural integration be undertaken, now that the artificial stimulus of WPA relief art has troubled the dormant minds of architects, engineers and fine-art-artists into thinking? And by that I don't mean the replacing of old, direct-hand techniques, by more indirect-hand (called machine) techniques, but by an entirely new spirit emerging in conjunction with new social and technological intensities.

\*Reported in The Architectural Record of September 1936.

## new scenic design by progressive play-direction

Designs in the Federal Relief Theaters are usually progressive. They are summoning the attention of the public and the professionals. Gerald Losey, "Living Newspaper" man, began with his rapid scene-battering WPA production "Triple Plowed Under," the Federal Labor-Theater's Boy number OI in contrast to Orson Welles who, twenty-one years of age, became, with his direction of Shakespeare's "Macbeth" placed in Haiti's surroundings, the Federal Triple A ART-Theater Boy number ONE.

Plowing under the traditional belief that only stars can handle a show on Broadway, Losey proceeded with the WPA second production, "Injunction Granted," and Welles with "Horse E Hat" and "Dr. Faustus," successfully playing to packed houses at a fifty-five cent top. This is real Folk-Theater, and credit must be given to the government. The productions are inexpensive in construction and rich in stage ideas. Although not very new in regard to the modern developments of the world's theater, are new enough for commercial Broadway, and bristling with young life.

We show a model of the unit-ramp-setting with and without actors (similar to one I used two years ago at the Metropolitan Opera) on which action of all acts and scenes took place. Different environments were indicated by properties carried on and off stage by the actors. Important historical annotations of the scene were projected on a big back drop in black and white and in color: portraits of American leaders were effectively projected on a white panel suddenly lowered to catch the projection. The first production, "Triple A Plowed Under" effected changes by using back-screen-projection, shadow puppets in motion and little rolling wagons on which actors move on and off with the scenery. Architects might note the effectiveness and efficiency of this sort of multi-scene production.

3



Photograph courtesy Art Service Project, WPA



WPA Federal Art Theater Photographs



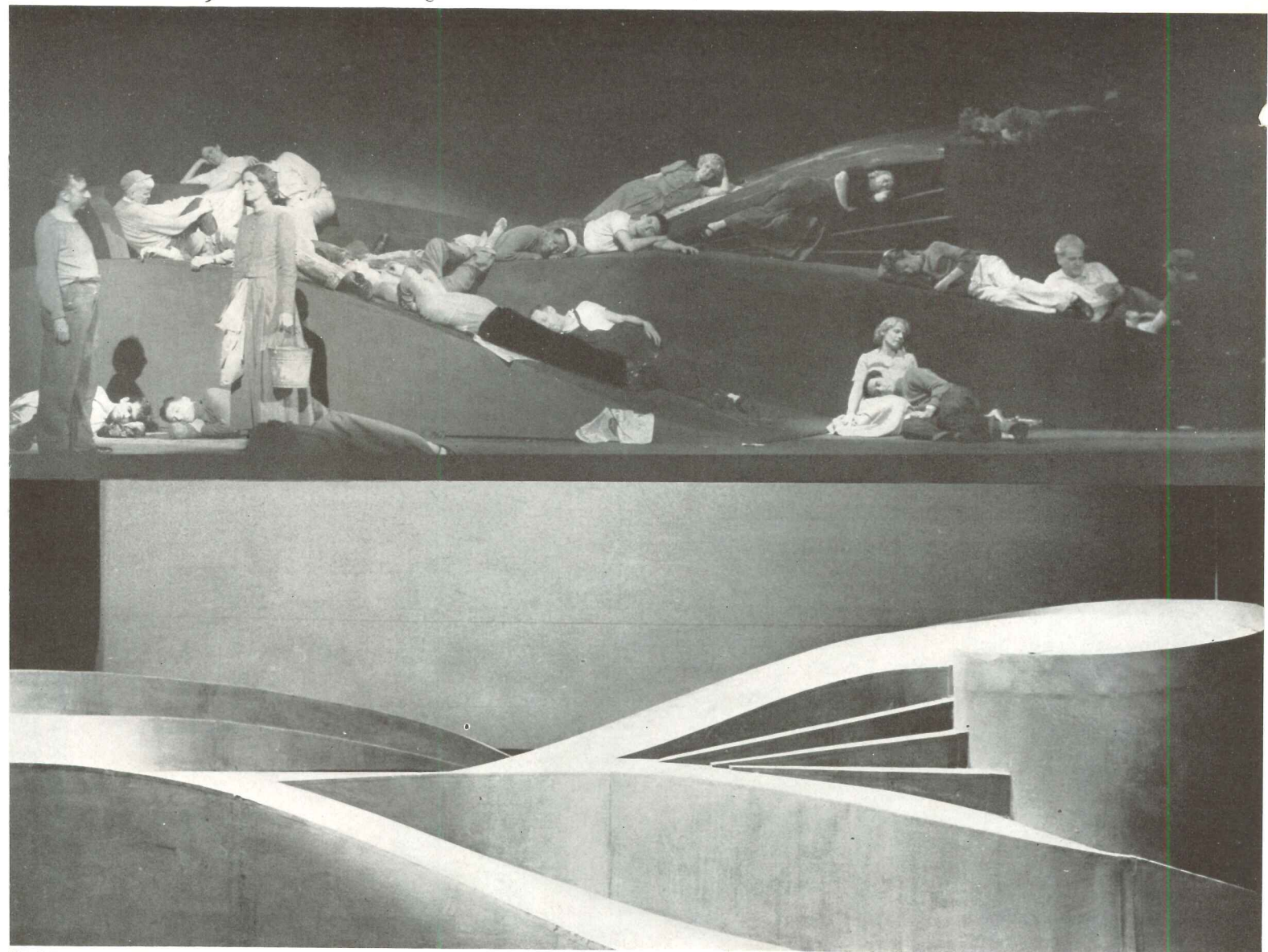

VPA Federal Art Theater Photographs

**slums survive** The French Citroën Auto-division for propaganda vision, under the direction of G. M. Haardt, returned from the "Roof of the World" with a film-odyssey called THE YELLOW CRUISE. Main purpose of the first motor trip across the Himalayas, from Beyrouth to Peking, was to demonstrate triumphant automotivity. For the designer this documentary film has many instructive views. First of all, the patented vehicle called Auto-Chenille, invented by A. Kégresse, which serves for mountain-climbing as well as soft-ground (sand) travel. The equipment is obviously unfit for narrow roads and water-locomotion. Frequently the expeditioners had to dismantle their Auto-Chenille-caravan into minute parts. After each river and lake crossing or surmounting unsuitable paths, the various machine fragments, having been carried on the shoulders of coolies, had to be painfully reassembled into mobile units. Paying due respects to the hardihood and tenacity of the leaders, it cannot be denied that the Himalayas are still to be conquered by the wheels of an automobile. This should not detain you from seeing the picture wherever it is available, since there are many "documents visuels" of old Asiatic building-structures not commonly found on library shelves. Most interesting of these: Century-old technique of theater-acting vitally alive today.—7 Tower-inclosed windmills, located on mountain tops, and the eternal slums of Turkestan, Kashmir, Mongolia, China, as well as the almost eternal sculptures of the Ming tombs.

Illustrations . . . frontispiece, pages 7 and 14 (upper)



**mobile design-symbols** The Mexican government initiated, long before our depression, creative work done by artists. For this purpose they employed not only native talents but also invited "foreign" Americans such as citizens of the U. S. A. and put them on the government pay roll—sculptor Noguchi, twin muralists Grace and Marion Greenwood and, lately, Paul Strand, embarrassingly little-known ace camera man. Photographer Strand worked in Alvarado, a fishing village on the Gulf of Vera Cruz, and the result is not a mural

but a film, for a change. The project was inaugurated by Paul Strand and Carlos Chavez, the composer, who was at that time (1933) head of the fine arts department in the secretariat of education in Mexico. Music was composed by Sylvestre Revueltas. Strand also wrote the story in collaboration with Velasquez Chavez, and supervised the entire production. Seemingly the best method of procedure to obtain such well-integrated compositions as Strand's film, is to work within a small group, whose members understand each other—men of uniform intentions

Photographs courtesy French Motion Picture Corp.

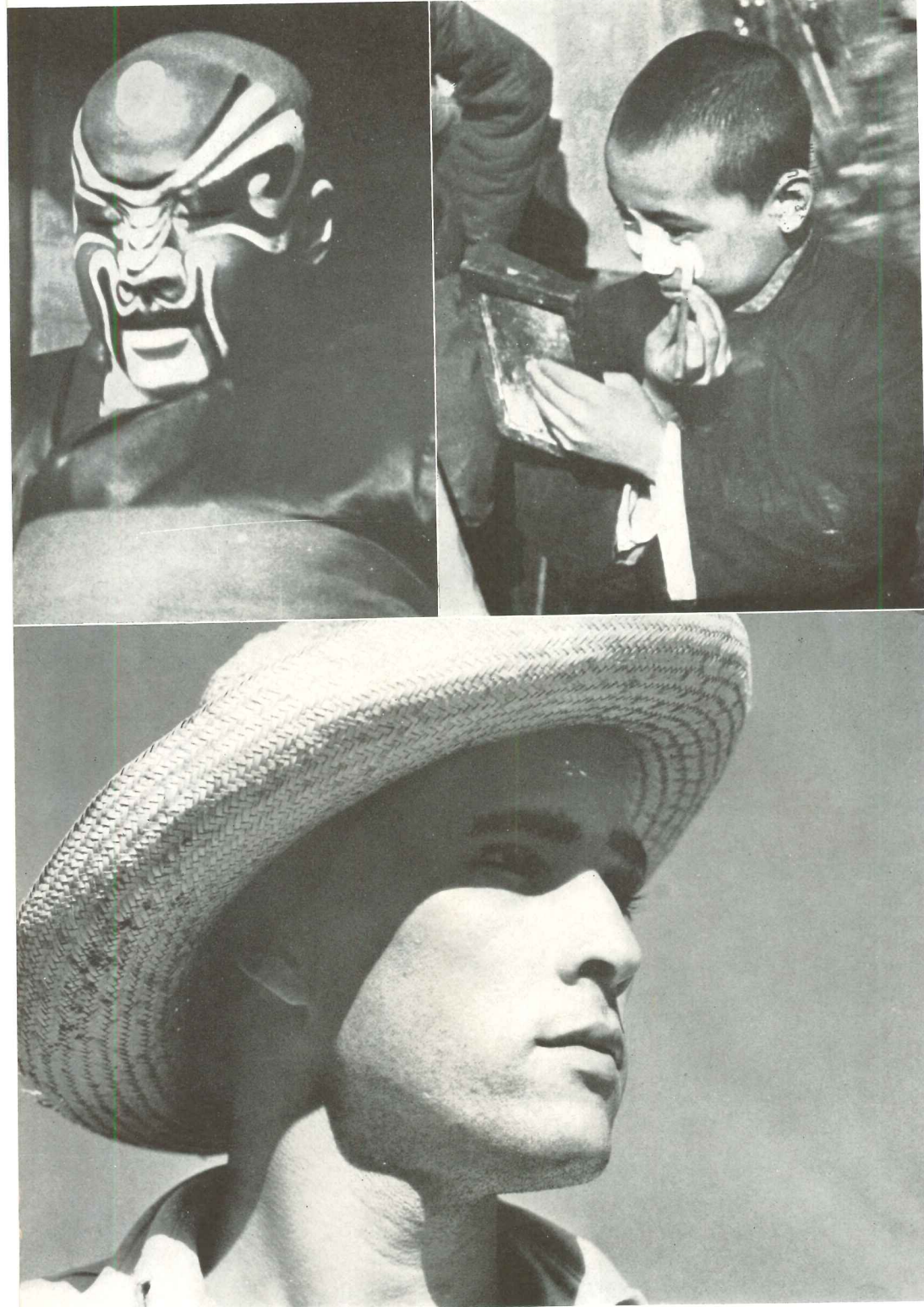

7

and varying skills—instead of being an outsider within a firmly crystallized super-production company. Of course, in the latter, financial compensation is greater, but the survival of an idea is usually at stake. The method of group work is limited in funds, but not in time and effort. And good spiritual and technical teamwork between designers, script-writers, technicians, actors and property-builders needs time, time, time. The Strand film took ten months, but that it can be done without losing ground in spite of super-production - competition was demonstrated by this American Strand even in conjunction with a foreign government, and by the American Virgil Thomson, with the support of private capital, by producing "Four Saints in Three Acts." Soon it will be known that the film "Redes" by Strand deserves a high place in the U. S. A. cinema annals. Its message, light-projected on a canvas screen will reach many more thousands, via the U. S. A. movies, than any paint-projected mural possibly could. Mexican and American designers might well consider; whether mobile design-symbols are not a **better medium for reaching the populace** than static mural fixations.

8



**Cinematic anti-propaganda** Photos-in-motion that might interest architects and music-makers is the film "Amphitryon." The treatment of vocal and pictorial correlation is new; the story is as old as Jupiter, if not older. As a matter of fact, it has been utilized so frequently that the French writer, Jean Giraudoux has titled his play "Amphitryon 38" to indicate that his is the thirty-eighth version of the tale. The plot concerns itself with the lust of Jupiter for an earthly woman and the complications which arise therefrom. In modern times munitions and money makers are invariably accused of fomenting wars, but the ancient Greeks had another cause for it. They had a poetic predilection for ascribing the troublesome source of this mischief to women. The film version, UFA's (39th), differs from Giraudoux (38th) in this, that in the play Jupiter instigates war in order to rid himself of Amphitryon, the soldier-husband of the beautiful Alcmena. In the film, Zeus-Jupiter discovers his earthly charmer by means of a magnifying glass (no propaganda for Zeiss) after her husband has already gone off to the wars. Disdaining his old tricks of appearing in the guise of clouds or celestial rays, Jupiter decides to transmute himself into a

human being. To quote, "the lowest creature of his creation," and appears as Amphitryon II. Of course, the second only to the spectator but not to Alcmena. It is superfluous to repeat the details of the story since it is too well known and, if you are unfamiliar with all the developments, see this pictorial demonstration offered in the film. But particularly call your attention to the Greek-Modern architectural settings of this motion picture, because as designers they merit your interest, if you like such style perversions. Conceived with good taste, the unit-set lends itself to a great variety of good shots. Its value might have been heightened by tapping a satirical vein, as was done in the treatment of the script, the costumes and direction. Its design-board values are credited to Robert Herlth and Walter Roehrig, well-known set-setters abroad. Greek maidens in the manner of Rockettes and Gold-diggers of 1937 cavort pleasantly through a musical score satirical in rhythm and cantilena, unfortunately lacking in the orchestration. A rare vocal continuity compensates for the comparative uninventiveness of the themes. However, you will probably enjoy the satire on war and authority, an unintentional propaganda-film in reverse, by Germans with French actors.



## NEWS DOCUMENTS I

World Pictures



**DEATH IN THE MACHINE AGE**

Streamlined car of Harry Pierpont . . . . . his last good-bye.

**DESIGN FOR DYING**

his last good-bye.

**PRIMITIVE DEATH**

Contemporary necklace design, Solomon Islands



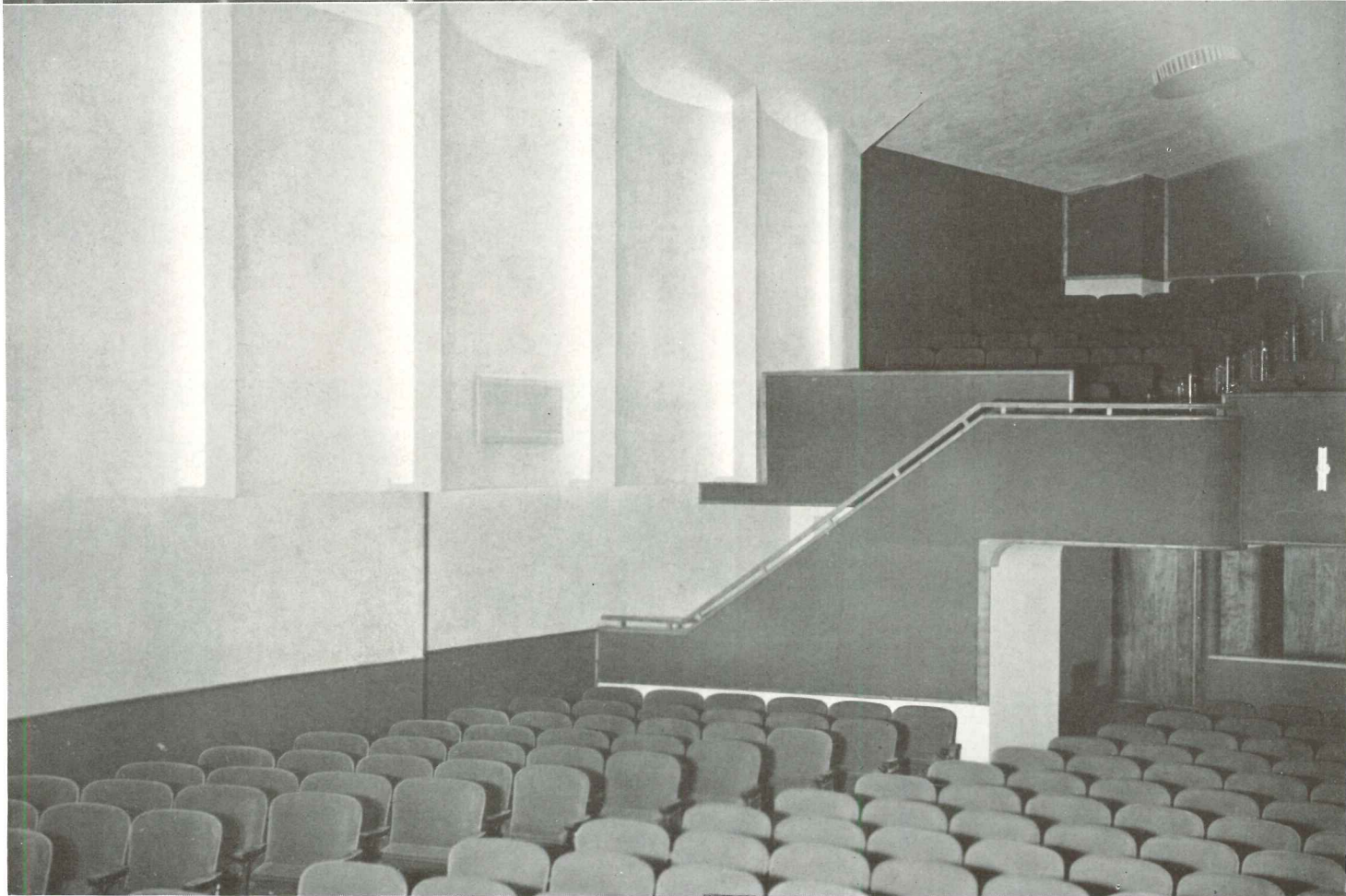



# MOTION PICTURE THEATERS

By BEN SCHLANGER

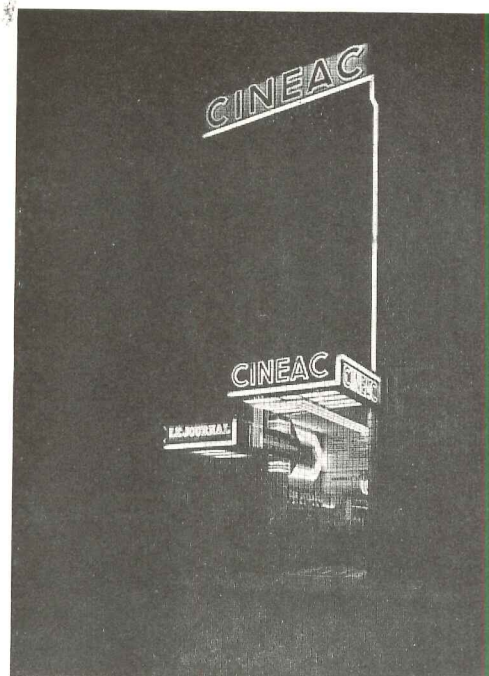

NEWS REEL THEATER—PARIS

There are two types of motion picture audiences each of which should be considered separately in determining the need for new theater construction. One type is the audience deriving from a given neighborhood or township, where the patronage is the same most of the time. The other type is located in popular busy shopping or theatrical districts, where the patronage is more transient. The number of transient patronage type theaters in a given location is subject largely to the importance of the locations, and the number of entertainment-seeking transients found therein. However, in the case of the community patronage type, the possibility of the erection of an additional motion picture theater is determined by taking several factors into consideration.

Since the community patronage theater is the most prevalent and most popular, it should be given most study. Here, a distinction should be made between the city neighborhood and the small town theater, a distinction, however, which is lessened to a certain extent by the automobile. For example, smaller and more frequent theaters would be necessary in small towns, were it not for the popular use of the automobile.

Basically, the need for the erection of new community patronage theaters can be determined by consulting these factors:

a. Density of population for a given area. 100 seats for 100 persons (based on attendance for 1936) is recommended.

Projection booth layout for machinery, wiring and other technical information can be found in Report of the Projection Practice Committee of the Society of Motion Picture Engineers. Copies may be obtained from the Society offices, 1215 Pennsylvania, New York City. Photographs and drawings of French theaters are reproduced by courtesy of *Architecture d'Aujourd'hui*.

- b. Availability of suitable film product.
- c. Frequency of attendance (increases with quality and quantity of available film product and reduction in admission prices).
- d. Obsolescence of existing theaters.
- e. Proximity of other theaters.

In the matter of type and number of motion picture theaters desirable, the patron and the exhibitor naturally have entirely different points of view. If the theater-owning exhibitor had his choice, there would not be much new theater construction. He would much prefer exhibiting films in a centrally located, large seating capacity unit, regardless of how inconvenient it would be for the patron to reach the theater or how obsolete and unsuited the theater might be for the effective enjoyment of the film.

On the other hand, the theater patron would rather have at least two theaters of more intimate capacity (of about 600 seats instead of one 1,200-seat house) convenient to him and offering more choice in film selection. Owing to the increasing number of desirable new films and the reservoir of good films made in the past, suitable for revival, a new attitude in motion picture exhibition has come about, popularizing the community intimate motion picture theater, located as closely as possible to the patron.

## CHOOSING A SITE

In choosing a location for the neighborhood or small town motion picture theater, first consideration should be given to the convenience of the patron in reaching the theater. Most desirable would be a location in the center of the population to be served.



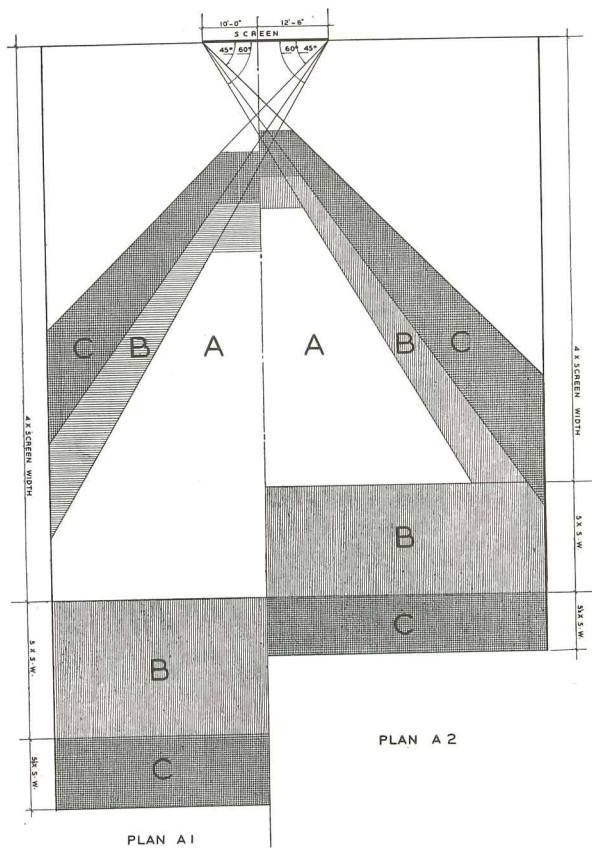

DIAGRAM 1. Valuable seating area limits determined by visual requirements, showing relative efficiency of differently proportioned shapes in plan (see text).

While it is of some advantage to be located on the chief business street of the neighborhood or town, it is not most essential. Usually, a location immediately adjoining the more valuable property should be chosen. Where property is excessive in cost, it is quite common to find the more valuable part of the property devoted to shops, locating the theater by means of an entrance from the important street, having the bulk of the building in the less costly area to the rear. As the importance of the motion picture itself increases, however, the use of costly land becomes less necessary. The tendency is towards a building which may have in it, at the most, a few small shops to help reduce the rental of the theater portion. Wherever possible, the use of minimum-cost land, eliminating the need for shops, is desirable, thus permitting full architectural advertising value for the facade of the theater building.

In selecting a site, a corner plot or an inside plot having a public street or alley immediately to the rear of the plot is most desirable for the arrangement of emergency exits, controlled by local ordinances. In the small town theater where automobile patronage prevails, parking space adjoining the plot is quite essential. A secondary entrance to be used by persons alighting from automobiles should be considered. For most efficient plot widths see **Diagram No. 2**, allowing additional width on inside plots for exit courts.

### FINANCING

The amount of money that may be justifiably invested in a motion picture theater structure and equipment is controlled by the necessary rapidity of amortization of original

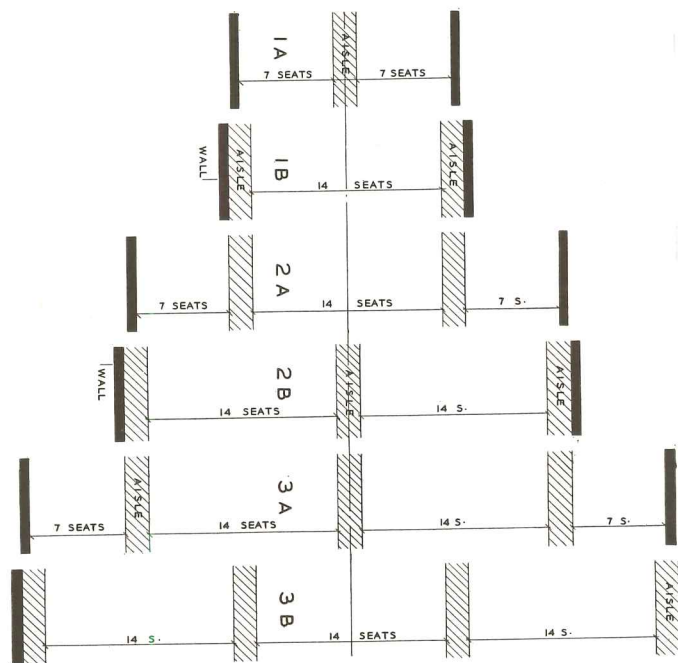

DIAGRAM 2. Schematic aisle arrangements for highest efficiency in space usage allowable by New York City Building Code (see text).

costs. Most investors feel that the highly specialized nature of the motion picture theater structure calls for a short amortization period. There is only one justification for this attitude and that is the possibility of a drastic shift in population from a given community. Large-scale housing studies and developments, and city and town planning tendencies obviate the necessity for considering this aspect. However, it is logical to assume comparatively short amortization periods varying from three to ten years for the equipment of the theater. Ten years is a fair amortization period for the construction cost. But for three important considerations which cannot be overlooked, home television may be offered as an argument to reduce this amortization period. First, the technical difficulties encountered in producing a suitable large enough home television screen have not as yet been overcome. Secondly, people still prefer to congregate seeking entertainment, as may be evidenced by the continuing popular demand of the motion picture in spite of the home radio. Thirdly, it is also quite possible that the motion picture industry would play a large part in the control of home television, distributing full length entertainment public assembly buildings and shorter programs to the home.

Economical land and construction costs, and simplification of interior architectural treatment should be stressed to reduce the initial investment. This does not preclude carefully studied planning which will afford proper functioning of the structure and ample comfort conditions for the patron.

### DESIRABLE SEATING CAPACITIES

The small town or city neighborhood motion picture theater minimum seating capacity is, on one hand, correctly determined by the technical problems involved and, on the other hand, by the commercial aspects of motion picture distribution. From a technical standpoint, considering ideal viewing conditions, no motion picture theater should have



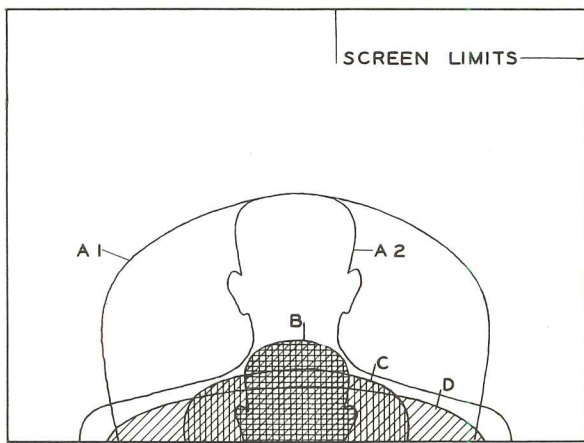

DIAGRAM 3. An outline of the motion picture screen shape with superimposed outlines indicating the portions of the screen obstructed from the patron's view from various seating positions (see text).

more than approximately 1,000 seats; preferably, nearer to 600 seats. Commercially, the chain-exhibitor prefers to control the first run of a given film and drain as much of the community population into one sitting as is possible. Recent construction of the more intimate motion picture theater by independent exhibitors, showing in most instances second and third-run films, has proven by the patronage enjoyed that the quality in film presentation is important, and that the patron prefers the theater having nearer to 600 seats. The intimate motion picture theater is more technically perfect for exhibiting films. This may be fully appreciated when the following data on maximum conditions advisable for viewing motion pictures are analyzed.

### FILM AND AUDIENCE SIZE AND SHAPE

The limiting factors in determining the maximum seating capacity from a standpoint of correct screen portrayal are: (1) physical width of the film, and (2) the proper relationship of the resultant maximum size screen to the audience shape and size.

The width of the film for professional use is 35mm. The absolute maximum size of screen to be projected from this film width is 35 ft. Further magnification of the film will produce (1) the visibility of the grainy structure of the film material, and (2) a tendency to destroy the contrast values in the photography. A 35-ft. screen necessitates a magnification of the film image to about 400 times its size. It is highly preferable to reduce this rate of magnification to achieve good pictorial quality. Where a good screen image is desired, the screen width should not exceed 25 ft.

The proper relationship between the screen size and the audience size and shape is determined by:

1. Avoidance of seating positions from which a distorted view of screen images occurs, distortion being due to the two-dimensional characteristic of the screen surface. (See **Diagram No. 1** showing tolerable and desirable viewing angles.)
2. Fixing minimum distance between screen and first row of seats. The maximum angle for horizontal range of vision, being about 60 degrees, determines this dimension.
3. Fixing maximum distance between the screen and the

row of seats furthest from the screen by

a. Visual acuity, that is, the ability to discern details of photography.

b. Proper subtended angle formed by the screen to the viewer's eye, insuring undistorted perspective of screen images.

**Diagram No. 1** shows absolute maximum viewing distance fixed at a distance measuring from the screen equal to five and a half times the screen width based on the screen shape proportion in present use. **Diagram No. 1** also shows limits fixed at five and four times the screen width—five being the advisable limit, and four being the more ideal limit confining the areas in which all of the photographic details of importance can be discerned by the viewer. While the close-up shot used in motion picture photography is effective and, to a great extent, helps vision from the remote seats, it must be remembered that for effective motion picture portrayal the photography must consist of a large proportion of what is known as middle and distance shots upon which the details to be discerned are smaller.

Limited viewing distances are essential to maintain a more intimate relationship of the spectator to the screen action. The screen area should, as much as possible, predominate the field of view of the spectators' eyes, thereby eliminating distracting excessive wall and ceiling surfaces and interven-

### JEWEL THEATER, BROOKLYN, NEW YORK

BEN SCHLANGER, ARCHITECT

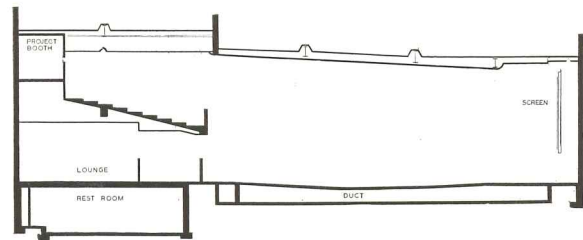

SECTION

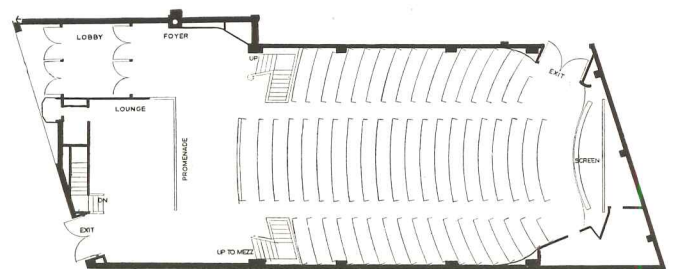

GROUND FLOOR

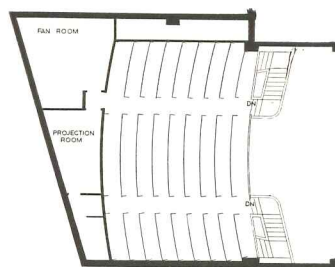

MEZZANINE

Mezzanine tier developed within unusually limited height releasing space below mezzanine for important lounge and lobby use. The objectionable long narrow shape is successfully treated architecturally by reason of the mezzanine elevation.



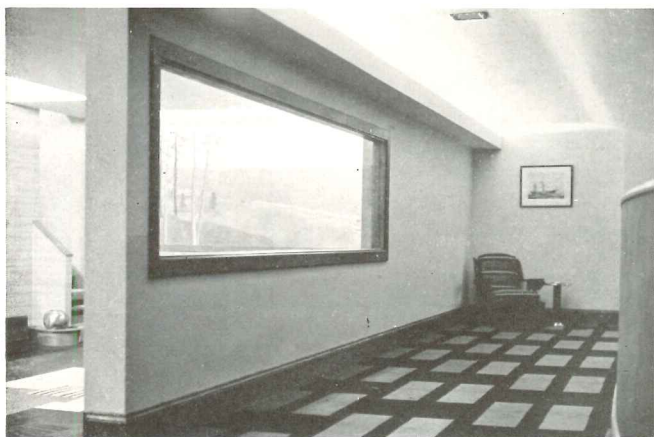
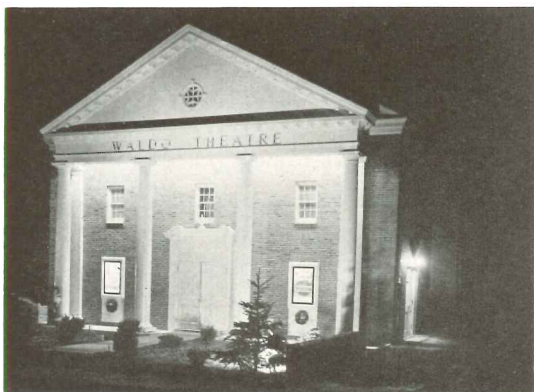

Top: night illumination adapted to Georgian facade for advertising value and general illumination. Center: an open counter in the outer lobby presenting an intimate quality for the sale of tickets. Below: the plate glass opening between the main lounge and the promenade space behind orchestra seats.

ing audience area. The viewing distance limits and the tolerable viewing angles given on **Diagram No. 1** have been arrived at from such investigations as have been carried on by the Society of Motion Picture Engineers and the author. Determination of preferable seat locations was made both from actual tests of tolerable distortion with a picked audience, recording their reactions, and observing the preferred seat locations as they became occupied in theaters in operation.

The factor of fixing viewing distances from a standpoint of determining proper subtended angles of the screen images is more directly concerned with the cinematography. Actually, there is one distance from the screen from which the picture may be viewed offering the same undistorted perspective and the same apparent sizes or subtended angles of images as seen from the camera lens point in the taking of the picture. This means that the original intended full force of the film director's efforts can be fully appreciated only at this distance from the picture. By coordinating both the focal lengths in projecting and taking optical systems, this point can be fixed at a distance marking exactly one-half of the seating depth, thereby reducing this phase of perspective distortion to the greatest minimum possible, provided that the seating depth is not excessive to begin with.

Viewing distances confined to limits set for proper visual acuity would be the best guide for practical purposes to determine maximum seating depth which would maintain proper subtended angles to the screen image.

**Diagram No. 1** shows two plans, A-1 and A-2, each representing one-half plan only on either side of the axis line. These plans illustrate the method to be used to obtain the maximum number of desirable viewing positions for a given area. Area A shows the desirable positions, B and C the tolerable but less desirable positions, all as determined by the factors already stated. Both plans contain the same amount of seating area. Plan A-2 requires a slightly larger basic rectangular plot but, what is more important, the A area percentage of the total seating area is about 20% less than in Plan A-1. A general rule derived from the findings in **Diagram No. 1** is that the screen width should come as

DIAGRAM 4 (below). A schematic longitudinal section of the motion picture theater showing vertical screen position and three different types of floor slopes (see text and accompanying photos explaining reasons for adopting different floor slope types and theaters where they have been used).

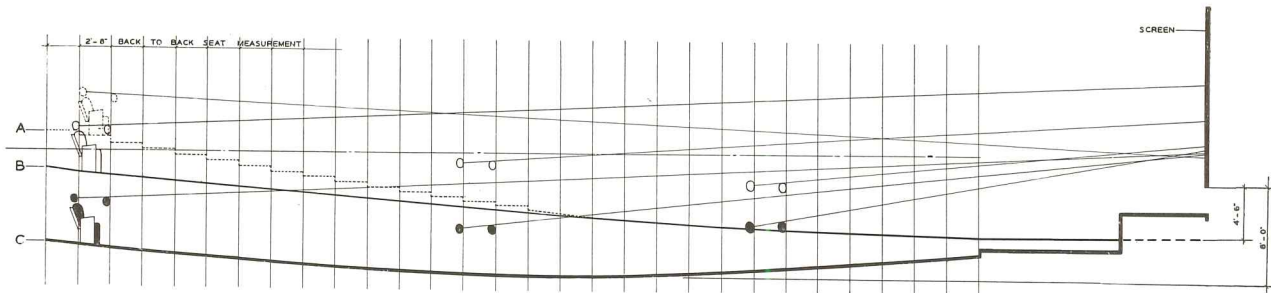



close to the width of the auditorium as is practically possible to obtain high efficiency in desirable seating positions. If possible, the width of the auditorium should be an amount equal to the screen width plus one-third of the screen width, to allow for possible wide-film adaptation, plus an additional amount equal to one-third the screen width for curtain space, and sufficient additional width for exit passage on either side of screen inclosure when such exits are necessary.

Practical adaptation of the rules here given is subject then to the selection of a screen width and auditorium width which will produce the seating capacity desired. The most efficient auditorium widths from a standpoint of obtaining the maximum number of seats with the minimum circulation area are fixed by Building Code Rulings. See **Diagram No. 2** which shows six schemes of aisle arrangements for auditorium widths based on New York City Building Code, which permits no more than 14 seats from aisle to aisle and no more than seven seats from wall to aisle. On the basis of this ruling, auditorium widths are most efficient at 14, 28, or 42 seats across the width. However, the number of aisles within the seating widths may vary as shown on **Diagram No. 2**. While the least number of aisles is desirable for space efficiency in some instances, the use of the scheme requiring an additional aisle is advisable. For example, the scheme in **Diagram No. 2**, Plan 1-a, for 14 seats in width requires less width of structure than scheme Plan 1-b, but at a serious sacrifice of choice seat locations. On the other hand, scheme Plan 2-a, for 28 seats across, proves to be both efficient in structure width and in preserving the best seat locations. In the case of schemes Plan 3-a and Plan 3-b, having 42 seats across, scheme Plan 3-b, although it requires an extra aisle, is preferable for the purpose of maintaining side wall aisles for extra emergency exits necessary in the larger capacity theaters. Scheme 3-b is recommended as the widest auditorium width advisable for the use of 35 mm film width projection. It is even advisable at a slight sacrifice in efficiency to decrease the 42 seats across in scheme Plan 3-b to 36, to keep the maximum structure width nearer to the maximum screen size.

**UPPER LEVELS OF SEATING**

Seating capacities ranging from 2,200 down to 300 seats may be developed using the rules given. The maximum number of seats on one floor is about 1,700 seats, the 2,200 maximum quoted being obtained with an upper tier of seating. Wherever possible, a properly designed upper tier of seating is advisable. Firstly, it makes a smaller plot more adaptable to a larger capacity; secondly, it has a tendency to reduce viewing distance and auditorium width, and thereby the screen size, which is always desirable. The assumption is, of course, that the last row of the upper tier would be no further away from the screen than is advisable for the lower tier. There is an additional value to be had with the upper tier of seating in that it produces a higher percentage of seating positions in the A area shown on **Diagram No. 1**, since the upper seats can conveniently be placed in this area.

The vertical disposition of the motion picture theater

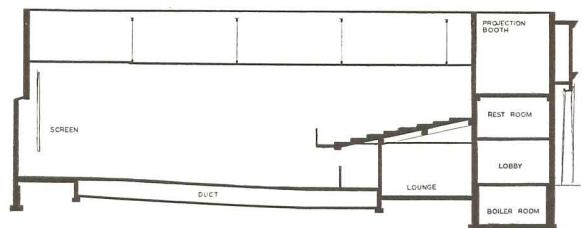
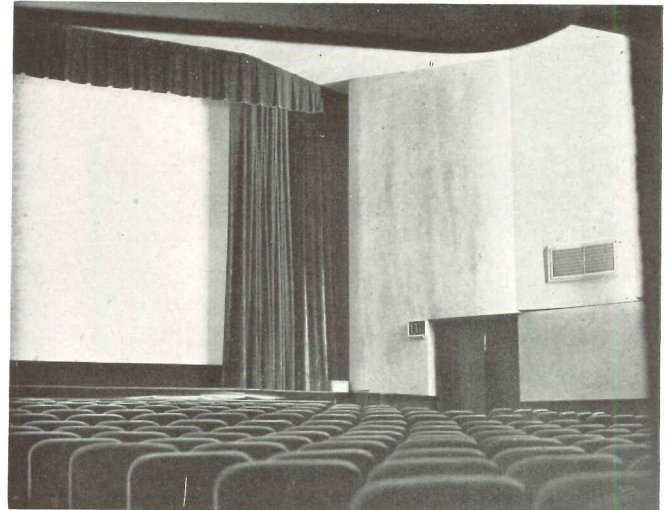

SECTION

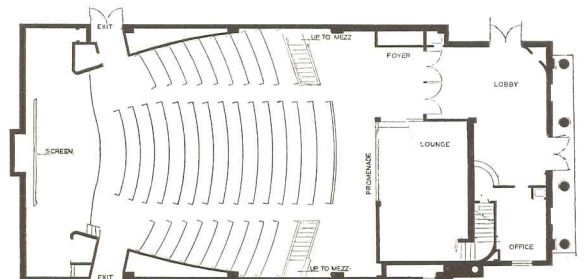

GROUND FLOOR

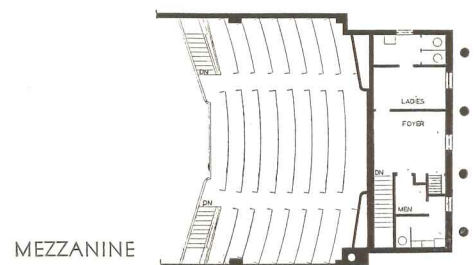

MEZZANINE

Spacious quality in the approach from the exterior to the intimate auditorium, a compact vertical plan using the reverse floor slope resulting in a minimum cubage.



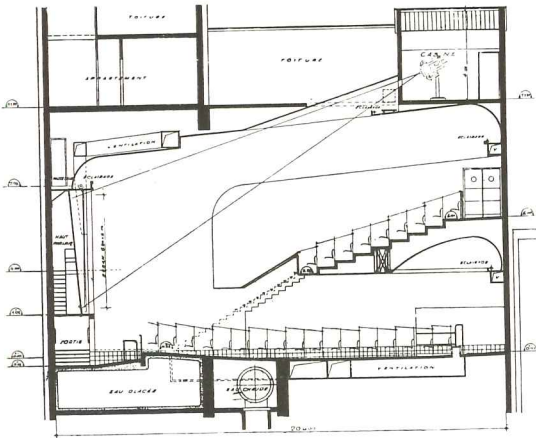
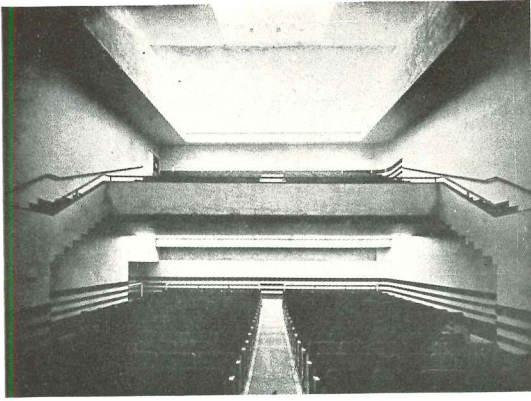

SECTION

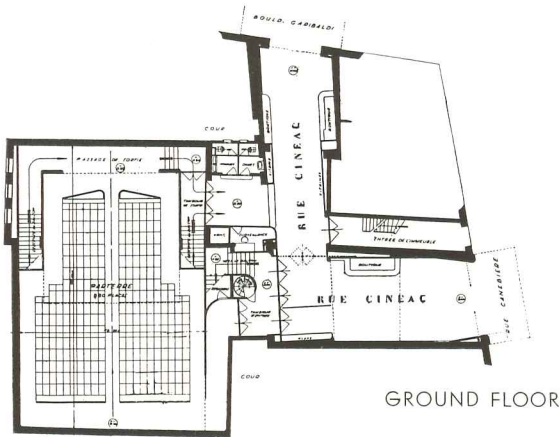

GROUND FLOOR

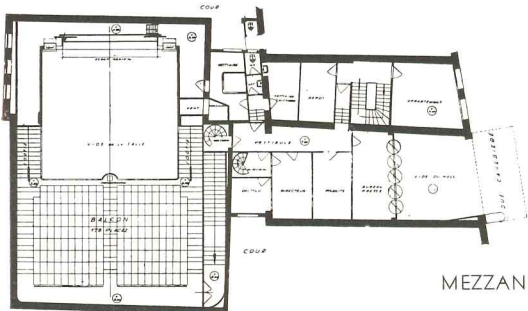

MEZZANINE

The addition of an upper level of seating in this theater made possible by the use of the reverse orchestra floor slope scheme developed by Ben Schlange.

form is important also for the following reasons:

1. The amount of obstruction of the view of the screen surface by the heads of the immediately preceding spectators.
2. Design of upper tier of seats.
3. Posture comfort.
4. The amount of distortion of the screen images.
5. The location of the projection booth.
6. Obtaining minimum number of cubic feet of structure for maximum number of desirable seating positions.

**FLOOR SLOPES**

**Diagram No. 3** shows various amounts of the area of the screen which cannot be seen by the spectators in various seating positions due to the obstruction caused by the head of the person seated immediately in front. The level of the seating floor in relation to the level of the screen and the character of the slope of the floor control the resultant amount of the obstructed screen area. In the case of the stage theater where no motion pictures are exhibited, only the slope of the floor is taken into account, the general level of the stage floor being always about the same. This is so because the level of the performance (that is, the stage floor) is necessarily a fixed level. It has been a fallacy in the past in designing the floor slope of the motion picture theater to conform to that of the stage theater. Unlike the stage floor level, the motion picture screen can be fixed at any level desirable for producing correct clearances and other conditions desirable for properly viewing the screen. The ability to overcome obstruction of the view of the performance becomes greater as the distance from the performance increases. Because the function of viewing the screen necessitates a seating plan of greater depth in relation to the width than does the function of viewing a stage performance, the obstruction problem is more serious in designing motion picture theaters. **Diagram No. 4** is a longitudinal section of an auditorium having in the depth 30 rows of seating. This is an average depth for motion picture theaters although a great number of larger capacity motion picture theaters run as deep as 40 rows, in which case the obstruction problem is even more acute.

Three different types of floor slopes are indicated on **Diagram No. 4**. The floor slope marked "B" is an adaptation of the stage theater slope for motion picture use. The confusion caused by the uncertainty of whether or not the motion picture was a form of entertainment capable of having a structure designed for its sole use has produced a great many theater structures which are not suitable for motion picture performance. An attempt was made to provide for stage performances at the sacrifice of the motion picture. Yet there is considerable objectionable obstruction from the remote rows of seating even for the stage performance. Slope B produces obstruction which amounts to from 22 inches in the first row to 107 inches in 30 rows, the obstruction increasing uniformly as the depth from the screen increases. This increase is in the reverse order of what it should be. See amount of obstruction as outlined in **Diagram No. 3** by lines A-1 and A-2. Both outlines A-1 and A-2 represent 93 inches of obstruction of the height of the screen, A-1 being from a seat in the rear rows and A-2 from:



a seat in the front rows. Note that greater obstruction in the front rows is more tolerable because less of the width of the screen is obstructed. In any case, however, 93 inches is an intolerable amount of obstruction. This happens to be the average amount of obstruction to be found in the last ten rows of slope B. Obstruction cannot be sufficiently minimized using the type of floor slope similar to slope B for two reasons. Firstly, it is impossible to increase the rate of pitch of the floor at the rear, the straight portion of the pitch already being the maximum permissible by most building codes and advisable for safe walking. Secondly, the elevation of the rear portion of the floor occurs generally at too high a position in relation to the position of the screen, thereby causing the sight line over the head of the preceding viewer to arrive at too high a point on the screen.

Floor slope A on **Diagram No. 4** is developed to show the rise necessary to overcome the objectionable obstruction found in slope B. Here the obstruction is reduced to an average of 22" for the last ten rows. The need for steepings in slope A introduces the stadium type of plan. The stadium plan is not adaptable for the motion picture auditorium because the circulation to seats must occur at the beginning of the stepped seating levels, thereby giving over to circulation in the form of a cross-over and vomitories the area of seating which happens to be at a distance from the screen most desirable for viewing motion pictures. Both floor slopes A and B are poorly adaptable for the addition of an upper tier of seating, because the necessary high position in relation to the screen position of an upper tier in these instances would cause a steep incline. The stepped levels of seating in steeply-pitched balconies must be more than a common riser height, thereby causing the introduction of intermediate steps in the aisles, a most objectionable feature because of the alternate narrow and wide treads in the aisle. Steep balcony design also has the disadvantage of forcing excessive cubage of structure, excessive projection angles due to the necessarily high placing of the projection booth and also produces seating positions at a height from which the screen images are distorted still further than the amount caused by the steep angle of projection.

The design of upper tier seating is controlled to a great extent by the design of the orchestra tier. A suitable solution for orchestra floor slope design is therefore important before attempting the design of the upper tier. Motion picture theater floor slope design is determined by 1. elimination of objectionable obstruction, 2. placing of the screen in the vertical sense at a level which would permit vision of its entire height without experiencing physical strain to see upward. Obstructed views of the screen can be overcome entirely by physical strain on the part of the patron to see the upper part of a raised screen and, similarly, physical strain can be entirely eliminated by adapting a low position for the screen, at the sacrifice of having resulting serious obstruction of vision of the screen. It is therefore necessary to determine maximum tolerable amounts of distortion and maximum upward vertical angles of vision for the most efficient floor slope design. See **Diagram No. 3**, which shows tolerable amounts of obstruction as indicated by areas outlined by B, C, and D. Note that obstruction area B, although

## NEWS REEL THEATER IN PARIS

P. DE MONTAUT AND A. GORSKA, ARCHITECTS

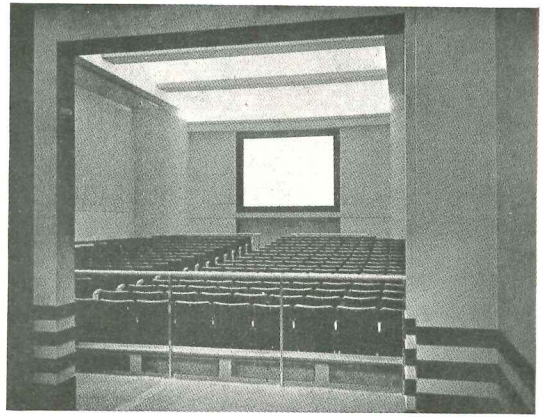

SECTION

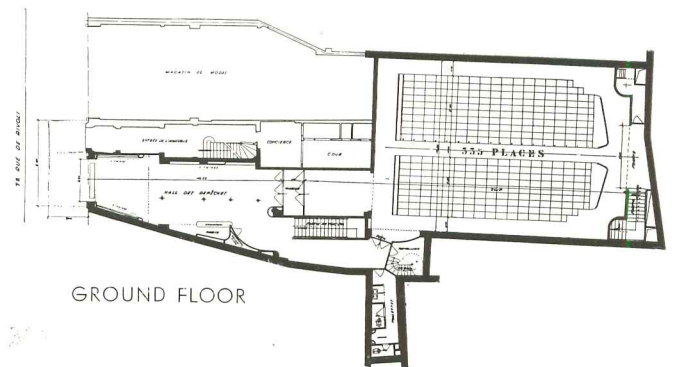
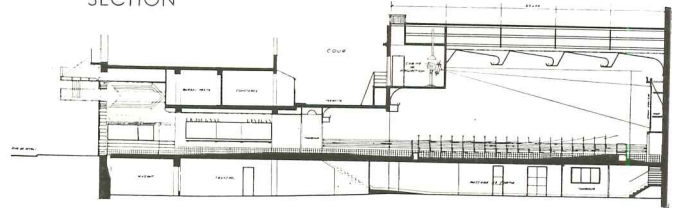

GROUND FLOOR

Another illustration of the use of the reverse floor slope, milder floor slopes and less obstruction of view of the screen resulting.

## REX THEATER AT ANVERS, FRANCE

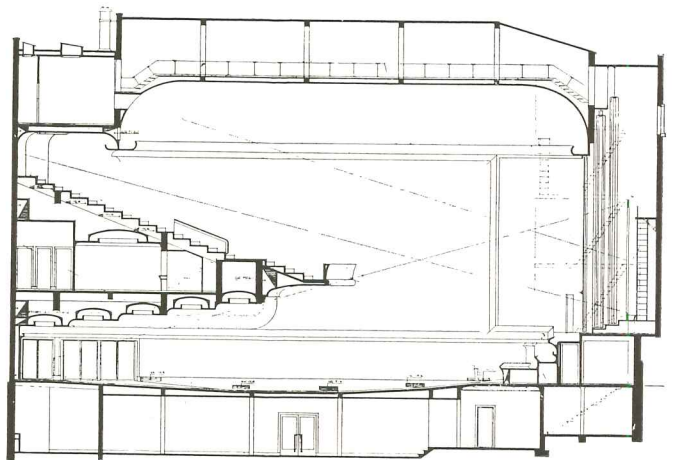

SECTION

Like the plan of the News Reel Theater at Marseilles, here too an upper level of seats is made possible by use of the orchestra reverse floor slope. Use of the floor slope "B" (Diagram 4) would have produced an impossible steep balcony in these instances.



## NEWS REEL THEATER IN PARIS

P. DE MONTAUT AND A. GORSKA, ARCHITECTS

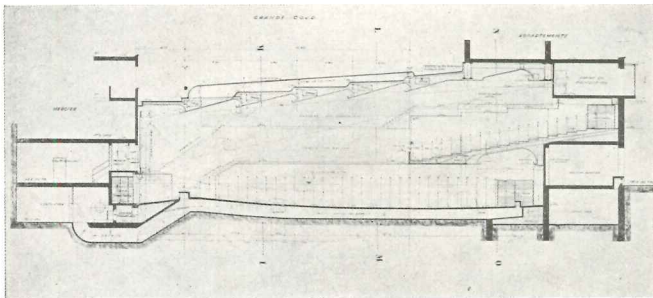
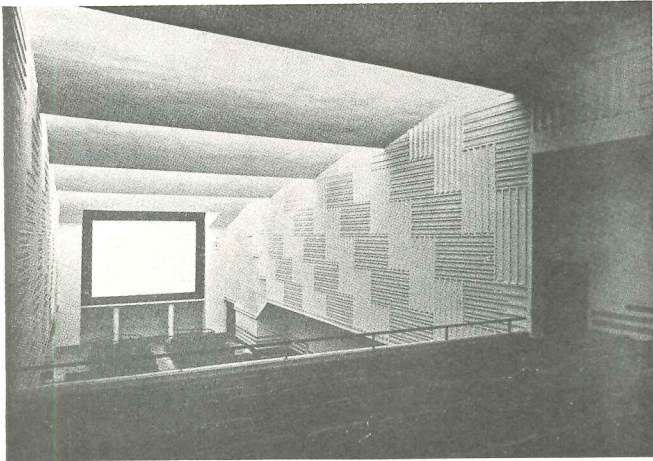

SECTION

Note the desirable mildly pitched upper level of seats and the orchestra floor slope similar to slope "C" (Diagram 4). An unusual amount of seats are obtained here for a narrow plot by the use of the floor slope scheme adopted.

## PEREIRE-PALACE THEATER IN PARIS

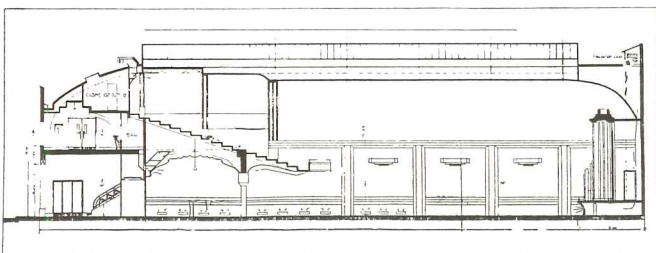

SECTION

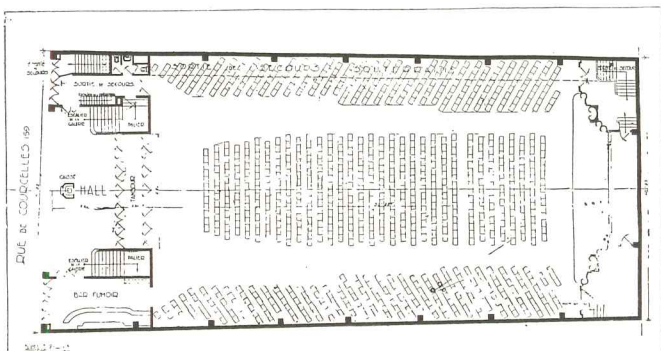

FLOOR PLAN

A plan using the stagger system in the placing of chairs making possible the use of a flat orchestra floor (see text).

greater in height, is less in area than area D, which is less in height. B obstruction is tolerable for the first ten rows nearer the screen and is equal to  $2/9$  of the screen height. C obstruction is tolerable for the next ten rows and amounts to  $1/6$  of the screen height. D obstruction is tolerable from the twentieth to the thirtieth rows and amounts to  $1/9$  of the screen height. Such obstruction is tolerable because important action on the screen in these areas occurs only a small percentage of the time and, for these infrequent scenes, it is not objectionable to sight a clear view between the heads of the preceding spectators. Floor slope B on **Diagram No. 4** is based on viewing the screen from between the heads of the spectators in the preceding row and over the head of the spectator two rows ahead. This causes constant shifting of heads to obtain an unobstructed view and proves to be most annoying to the patron. A system of staggering the seats to avoid this shifting of heads has been in use, a good example being the Cinema Periere Palace in Paris, where an absolutely flat orchestra floor was used.

When the stagger system is used with a flat floor, the screen has to be raised an objectionable amount for the front seats to afford a clear enough view over the head of the spectator two rows ahead. The stagger system also creates a jagged aisle line and a waste of floor area equal to one seat loss for every other row.

Floor slope B on **Diagram No. 4** has the screen placed at an elevation which would not cause any physical strain to view its entire height, but to raise the screen in relation to slope B to reduce obstruction to the tolerables B, C and D on **Diagram No. 3** would place the screen at a level of about six and a half feet higher above the low point of slope B. This would cause serious straining of the neck and eye muscles in viewing the screen in the rows nearest to it where the upward angle to the top of the screen is sharpest. Floor slope C is designed to limit the obstruction areas to B, C and D shown on **Diagram No. 3**. While the low point of slope C is  $3\frac{1}{2}$  ft. below the low point of slope B in relation to the level of the bottom of the screen, there is very little additional physical strain caused in viewing the upper areas of the screen than is the case in slope B. The lowest level on slope C is moved back to a point where upward vision is automatically increased without experiencing physical strain. Note that the screen can be placed still lower in relation to slope C without increasing obstruction to any serious degree, while a lower placing of the screen in relation to slope B would increase obstruction beyond the amount which is objectionable to begin with. See accompanying photos and diagrams of various adaptations of slope C in theaters recently erected. Note the use of the upper tier of seating in conjunction with this type of floor.

It would not have been possible to include an upper tier of seating in these examples if slope B of **Diagram No. 4** were used for the orchestra floor because the pitch of the upper tier would have become excessive. It is obvious therefore that the use of slope C or some modified form of slope C makes it possible to adapt comparatively small plots for motion picture theater structures. Usually the upper tier of seating can be included within practically the same height as would be used for just one tier of seating.



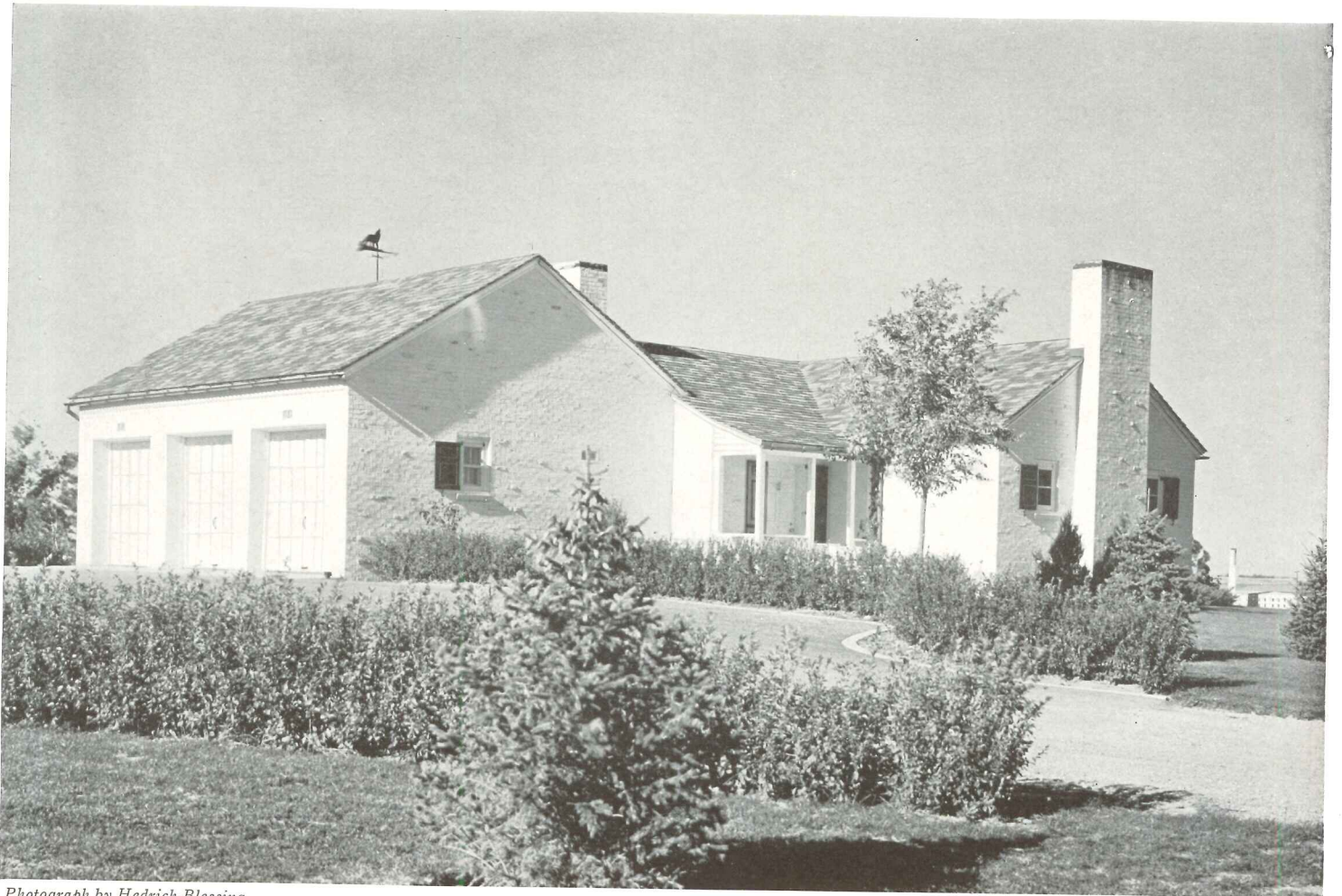

*Photograph by Hedrich-Blessing*

**HOUSE OF MR. AND MRS. JOHN MORRELL FOSTER**

**SIOUX FALLS, SOUTH DAKOTA**

HAROLD SPITZNAGEL, ARCHITECT

THIS HOUSE was originally designed as a summer residence, located in a rural section, which necessitated the construction of sanitary and water services usually present in an urban locality. As the construction progressed the owner decided to build the house for year-round occupancy, should he so desire.

THE FOUNDATION is of concrete. WALLS: common brick veneer, painted white; Insulite sheathing; Rockwool insulation on all exposed surfaces. ROOF: Ludowici-Celadon variegated shingle tile. Downspouts, gutters and flashings are of copper. INTERIOR WALLS: No plaster; walls lined with U. S. Gypsum sheet rock. Joints stripped with metal A and canvased. Bathroom walls are of Formica, with chromium-plated moldings; shower stalls are of structural glass. FLOORS: rubber tile in kitchen, pantry and bathrooms; remainder of floors are carpeted, with exception of the living room which is finished with random width oak planks, set in mastic, on a waterproof, earth-bearing concrete slab. Dietrich metal cabinets in kitchen and pantry. HEATING: Mueller blower type furnace; McIlvain oil burner. FLOODLIGHTING: the grounds are illuminated for a distance of approximately 100 feet in all directions by Holophane lenses, installed in metal frames set flush with the brick walls. The lights are controlled individually or collectively from five points located within the house.



# PRIVATE HOME

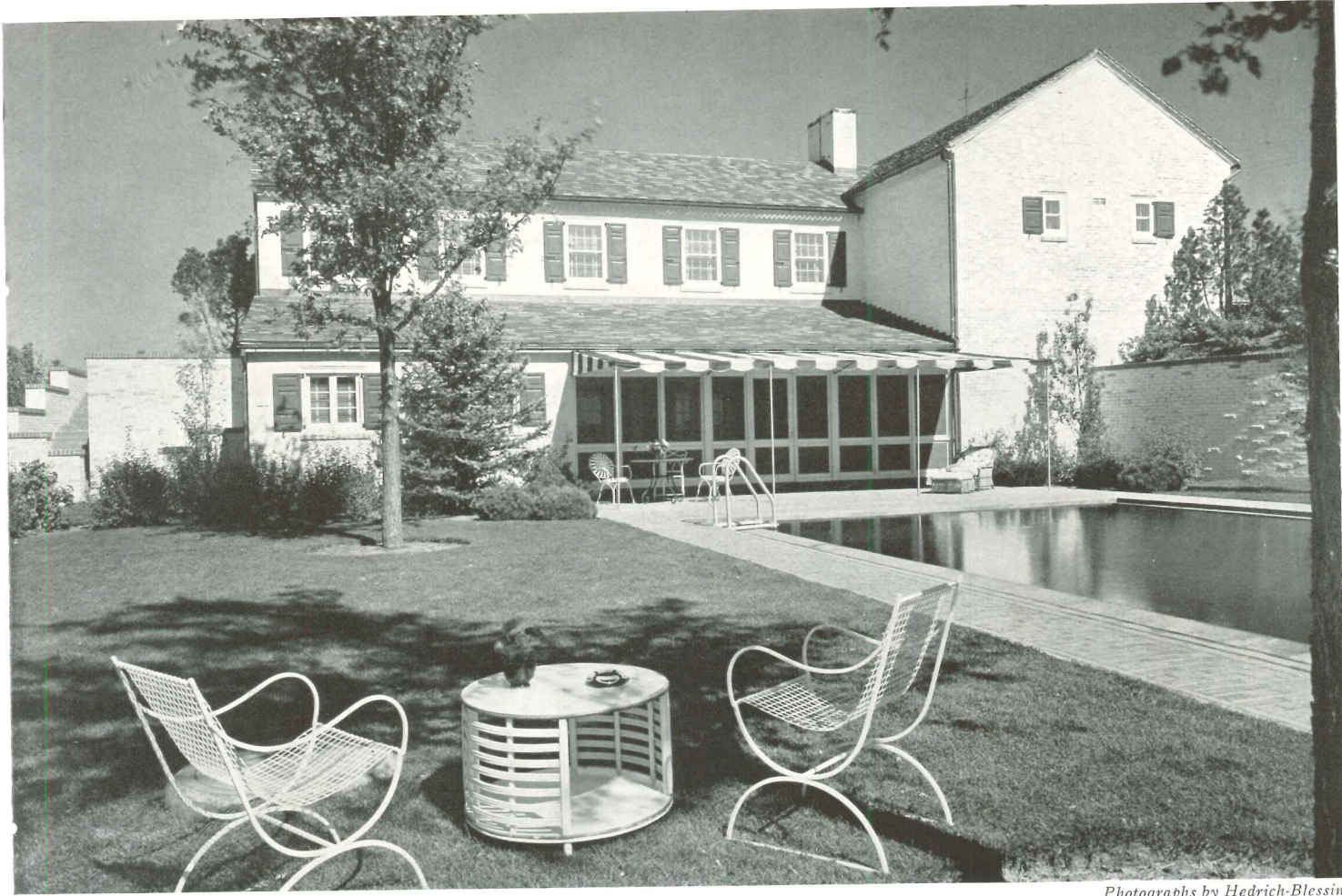

Photographs by Hedrich-Blessin.

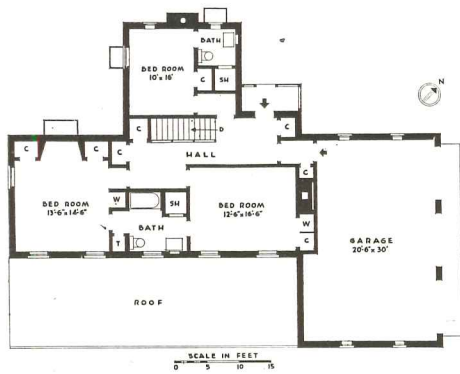

UPPER LEVEL

**HOUSE OF MR. AND MRS. JOHN MORRELL FOSTER**  
 SIOUX FALLS, SOUTH DAKOTA  
 HAROLD SPITZNAGEL, ARCHITECT

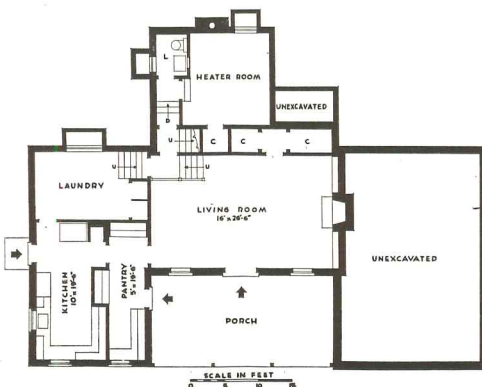

LOWER LEVEL

Above: Rear view of house,  
 showing swimming pool.  
 Opposite: Entrance detail.







# PRIVATE HOME



Photographs by Walter Dally

## HOUSE OF HUGH MC DOWELL

MILWAUKEE, WISCONSIN

GEORGE SPINTI, III, ARCHITECT

This house was placed lengthwise of lot, thereby following a side line restriction of the village on frame buildings.

The exterior walls are insulated with 4" Rockwool, and covered with cypress siding painted white with contrasting dark green blinds. Garage wing and chimneys are of buttered mortar field stone.

It was the owner's desire to place the living room at the rear, taking advantage of view. A bedroom was required on the first floor and dining room so placed as to open directly off the living room. The interior trim is painted light ivory.

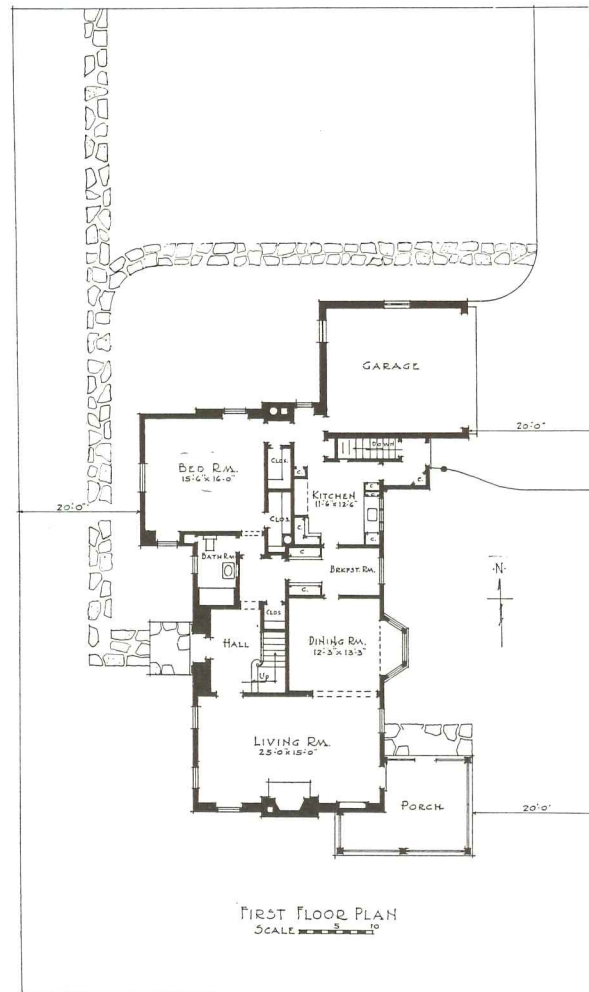
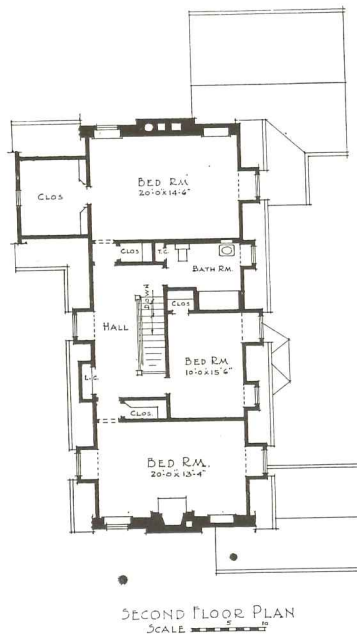





**HOUSE OF ARMIN SCHWARTING**

MILWAUKEE, WISCONSIN

GEORGE SPINTI, III, ARCHITECT

The owner of this house was desirous of having three bedrooms, bath, separate lavatory space, and open porch, to accommodate a family of three.

The house is built with a common brick veneer exterior on a concrete block basement wall with 4" Rockwool insulation. The exterior is painted white with dark green blinds. Check rail windows are hung with "The Unique" sash balance and weather-stripped.

The interior trim generally is painted a light ivory and the walls papered with a washable paper. The breakfast bay and bookroom woodwork are stained a cinnamon brown.

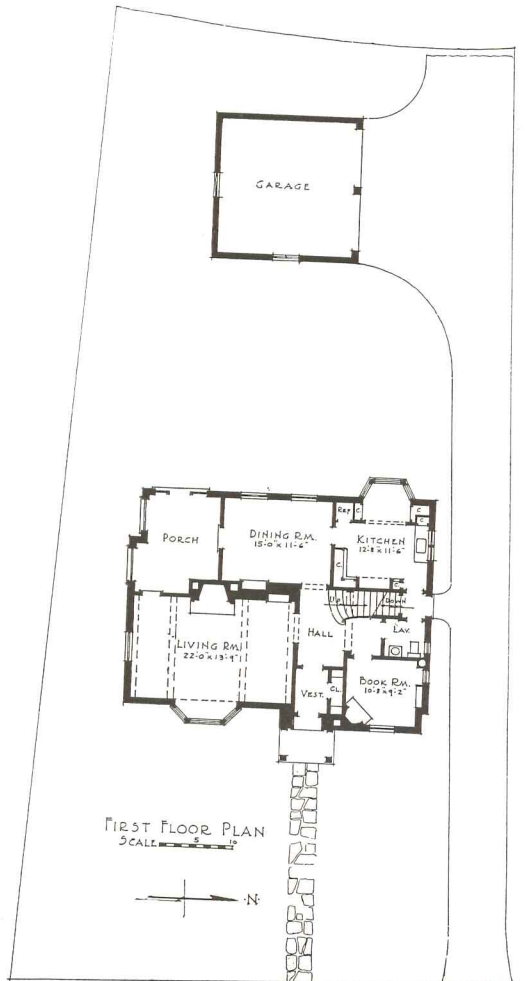



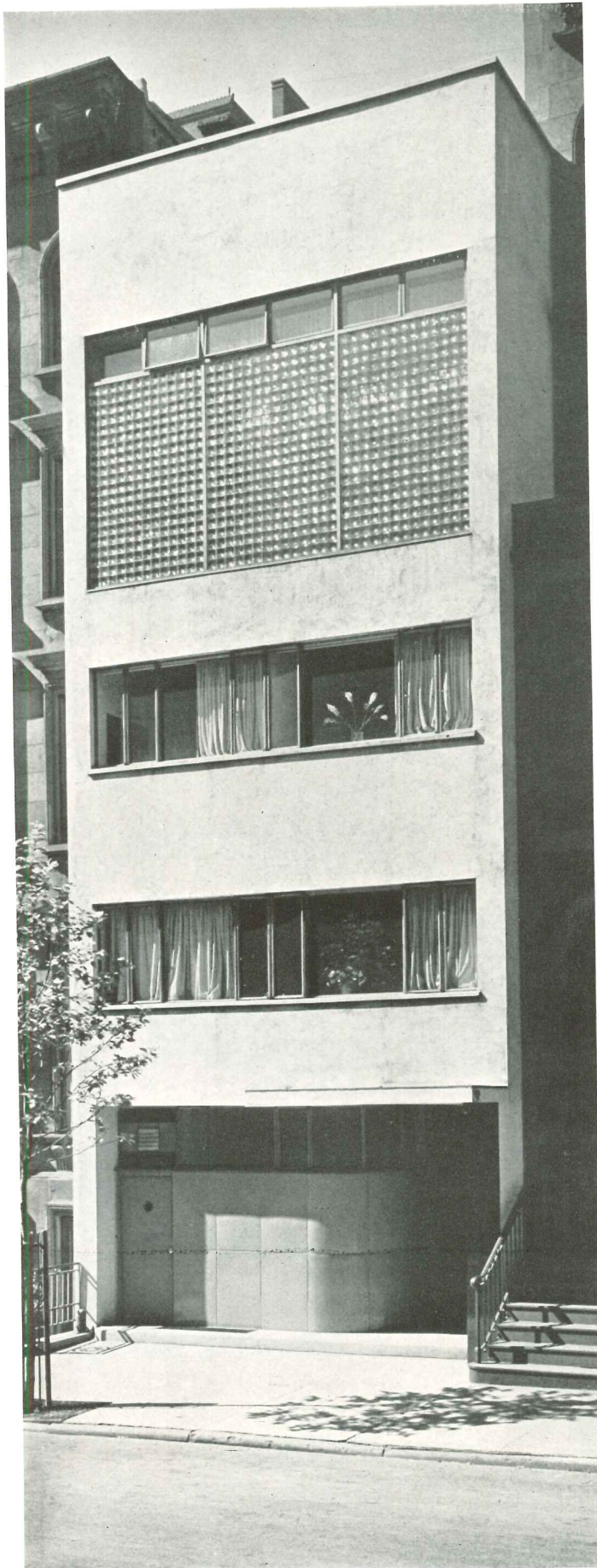

**HOUSE FOR MRS. R. C. KRAMER**

NEW YORK CITY

WILLIAM LESCAZE, ARCHITECT

This house, utilizing one of the rare new single-family opportunities in Manhattan, provides spacious living room on the fourth floor at the top for the family composed of parents and daughter; the dining room and related services are on the ground floor, with a terrace overlooking the garden; the daughter's headquarters are on the second floor (Bedroom No. 2 on the plan), the parents' bedroom is on the third, and the rest of the two middle floors is devoted to guest rooms and the library. The curved wall of the third and fourth floors, on the south or garden side, is meant for better orientation to morning sunlight and view. A push-button elevator runs to all floors.

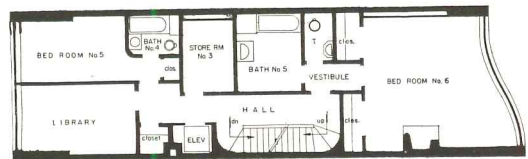

THIRD FLOOR

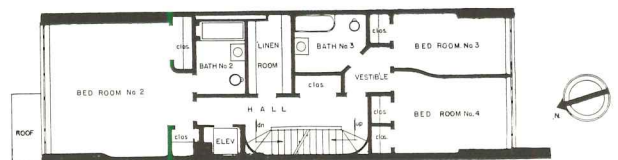

SECOND FLOOR

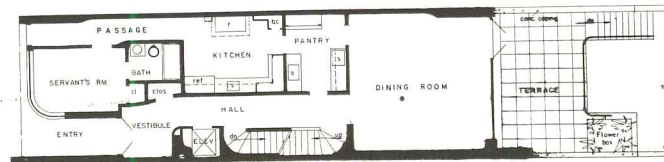

FIRST FLOOR

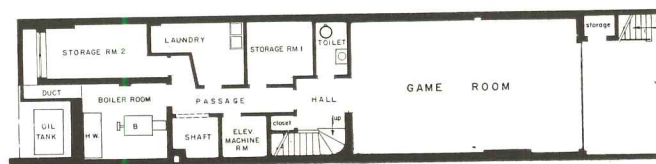

BASEMENT FLOOR





Photographs by Laura Von Scharendorf

Construction is fireproof, using common brick which is covered with stucco on the street side and painted white on the garden side, reflecting sunlight on the plants. Floors are concrete arches on bar joists. Hope steel sash is used throughout; the stair is steel covered with carpet. Glass brick in the living room street wall is surmounted by a transom for cross ventilation.

LIVING ROOM. Above: the southern end beyond the windows shown in the picture is the conservatory or sun porch occupying the S-curve shown in the plan of the floor below. At right: the same end of the room showing elevator door and stairway. The room, with a 12-foot ceiling height, occupies the full top floor and is informally separated into different use-sections by spurs of furniture such as the fireplace seat and bookcase illustrated. All lighting from coves and troughs; no "fixtures" or "lamps."





# PRIVATE HOME

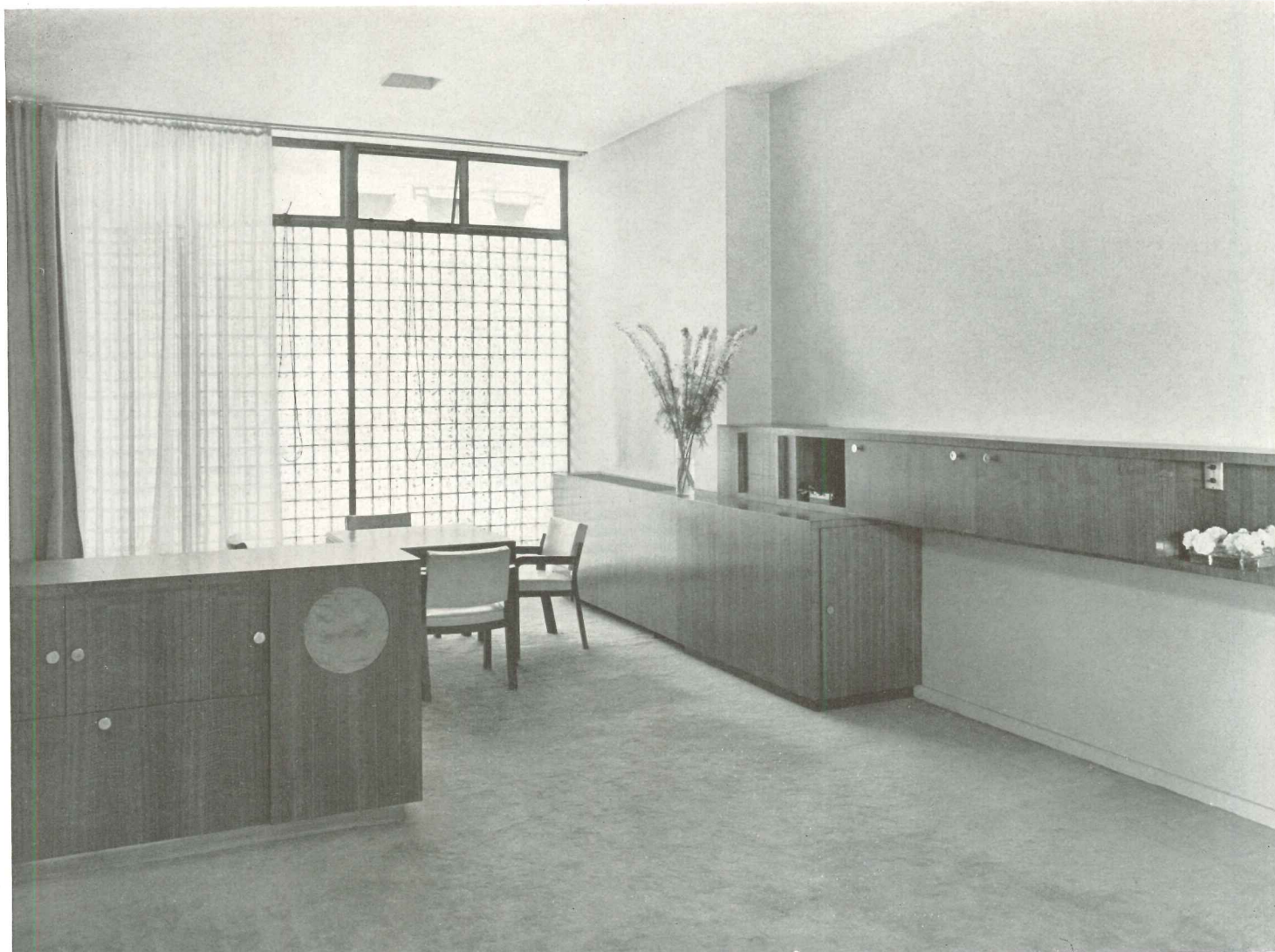

*Photographs by Laura Von Scharendorf*

## HOUSE FOR MRS. R. C. KRAMER NEW YORK CITY

WILLIAM LESCAZE, ARCHITECT

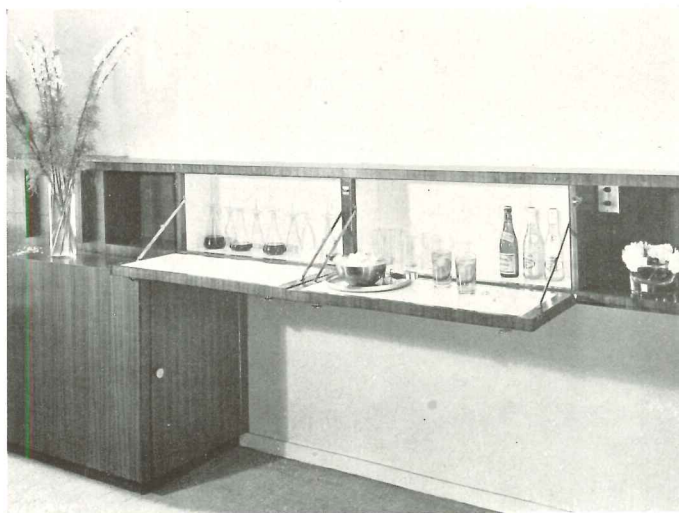

The living room is informally divided by spur lines of furniture into three general use areas. The guest leaving the elevator enters the general reception area (see foreground above); to his left, toward the street, is the space devoted to bridge table (see above and opposite); to his right, toward the garden, is the fireplace area (see previous page) and glass screen-wall opening to the conservatory porch. Lighting is entirely from troughs, covers and skylights, totally eliminating fixtures. Wall-sections are subtly varied in color from white through off-white to gray for space articulation.

Above: living room looking north. In foreground is the central area; to the rear, the bridge table under built-in ceiling spotlight. At left: detail of the wall cupboard, showing an urbane bar for people of quiet habits. Opposite bridge table. In this room the furniture is walnut; carpet and hangings tones of beige and tan; walls subtly divided, by sections, white, off-white and gray.







# PRIVATE HOME



*Photographs by Laura Von Scharendorf*

## HOUSE FOR MRS. R. C. KRAME NEW YORK CITY

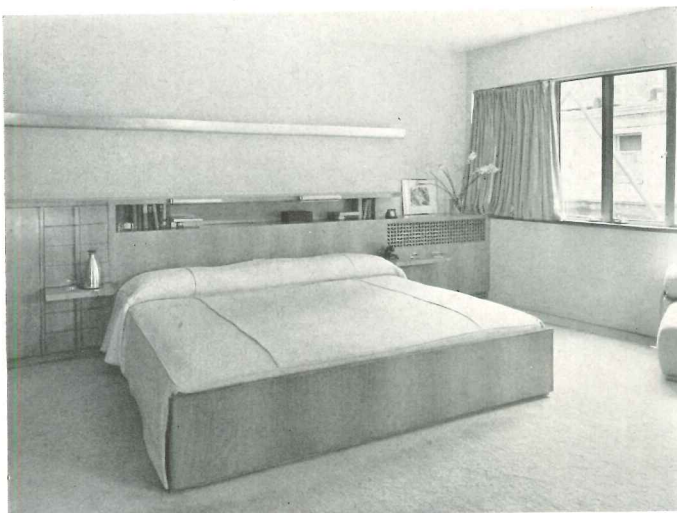

THE MASTER'S BEDROOM. Above: view toward fireplace. Mirror to the right is approximately square in shape, doubling the room's apparent size and repeating the play of curved and straight boundaries. The furniture is pearwood. Left: The wall cabinet at the head of the bed includes sliding shelves at convenient arm height.





WILLIAM LESCAZE, ARCHITECT

DAUGHTER'S ROOM. Above: bed and desk. At right: couch and easy chairs. The room is large enough and so placed that the daughter can have good times with her friends without upsetting the older people in the house. A gay color scheme, with Mexican mahogany furniture, peach-colored coverings, yellow curtains.

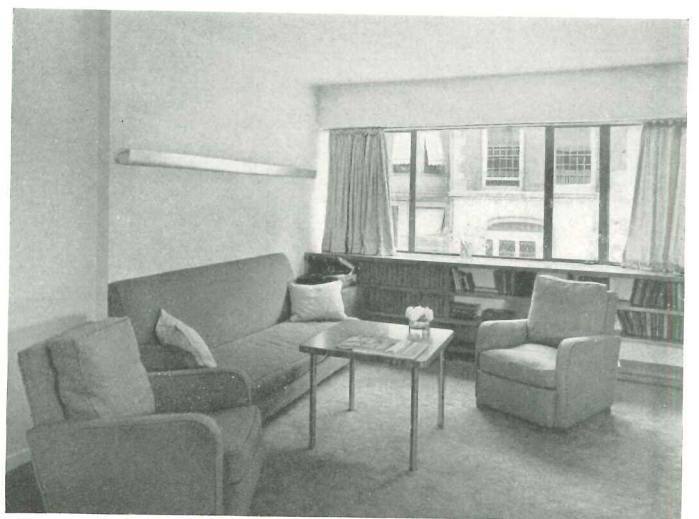



# PRIVATE HOME



## HOUSE FOR MRS. R. C. KRAMER

NEW YORK CITY

WILLIAM LESCAZE, ARCHITECT

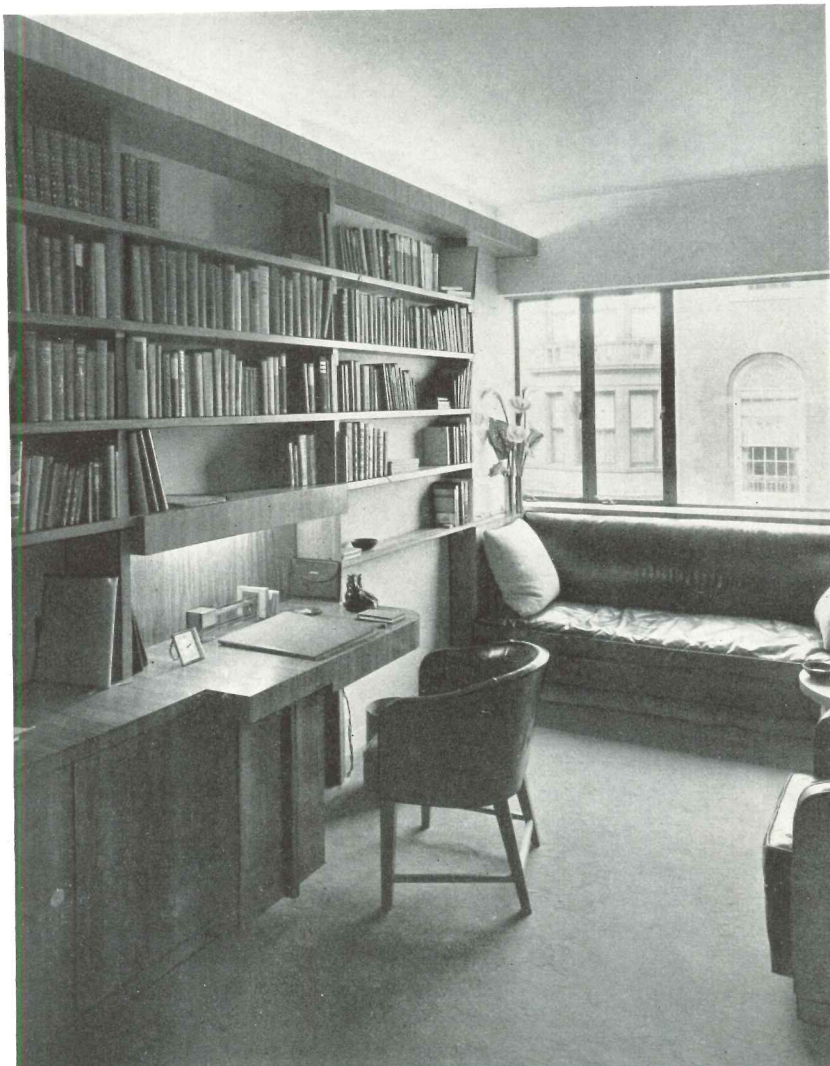

Above: the dining room looks out on a garden terrace. The "serving table" can be used as an extension. Left, below: the library, feasible as a guest's living room. Right, below: bathroom detail, showing correctly lighted mirrors on medicine cabinet designed by the architect.



*Photographs by Laura Von Schnarendorf*



**ACCOUNTING ROOM, OFFICE OF  
BATES & SCHOONMAKER, WINE MERCHANTS  
NEW YORK**

ERNEST BORN, ARCHITECT

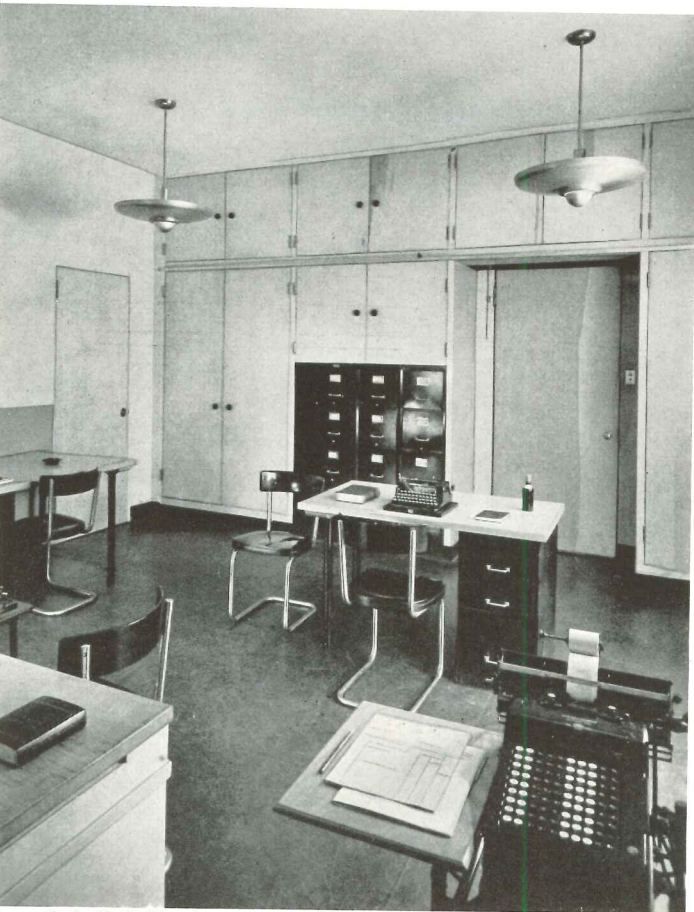
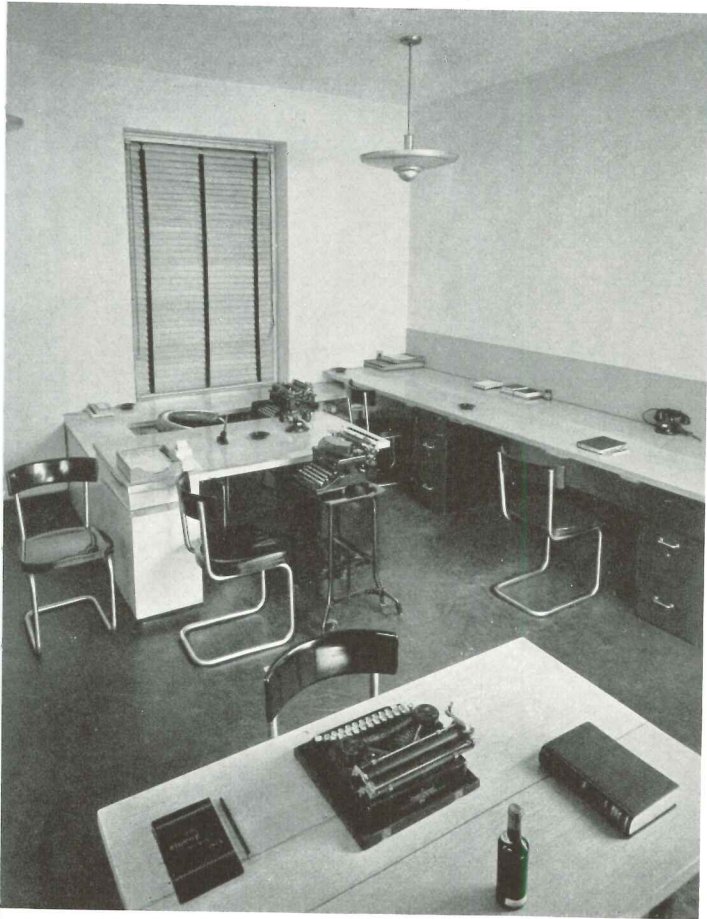

Since this room is used for "close work" in accounting and bookkeeping, the architect ran the illumination up to about 50 foot-candles using a Kurt Versen standard fixture; the opal glass of the original fixture was replaced by aluminum since the glass in no way affects the efficiency of the unit.

The room contains: desk for Mr. Bates so related to the head bookkeeper that he may swing around in his chair and work with her; long work table, with steel files under, for three bookkeepers; wardrobe for hats and coats; steel filing cabinets; steel safe; storage place for ladder used in reaching storage space above lower space. Files, wardrobe, etc., are built out flush in one plane. Woodwork is varnished white pine; satin chromium-finished hinges on doors. Steel files are black with chromium hardware. Walls are painted off-color white. Linoleum floor.

Photographs by F. S. Lincoln



## SHOWROOM



### **OFFICE AND DISPLAY ROOM OF THE FLORIDA PUBLIC SERVICE COMPANY**

DELAND, FLORIDA

GOUVERNEUR M. PEEK, ARCHITECT

This remodeled building is constructed of concrete block walls with reinforced concrete floor slabs, cast-iron columns, wood roof. It is rented by the Florida Public Service Company for its local office, display rooms and demonstration work in connection with gas and electrical appliances. Their lighting and advertising staff collaborated with the architect in the design and layout of the heating, ventilating and electrical equipment.



# SHOWROOM

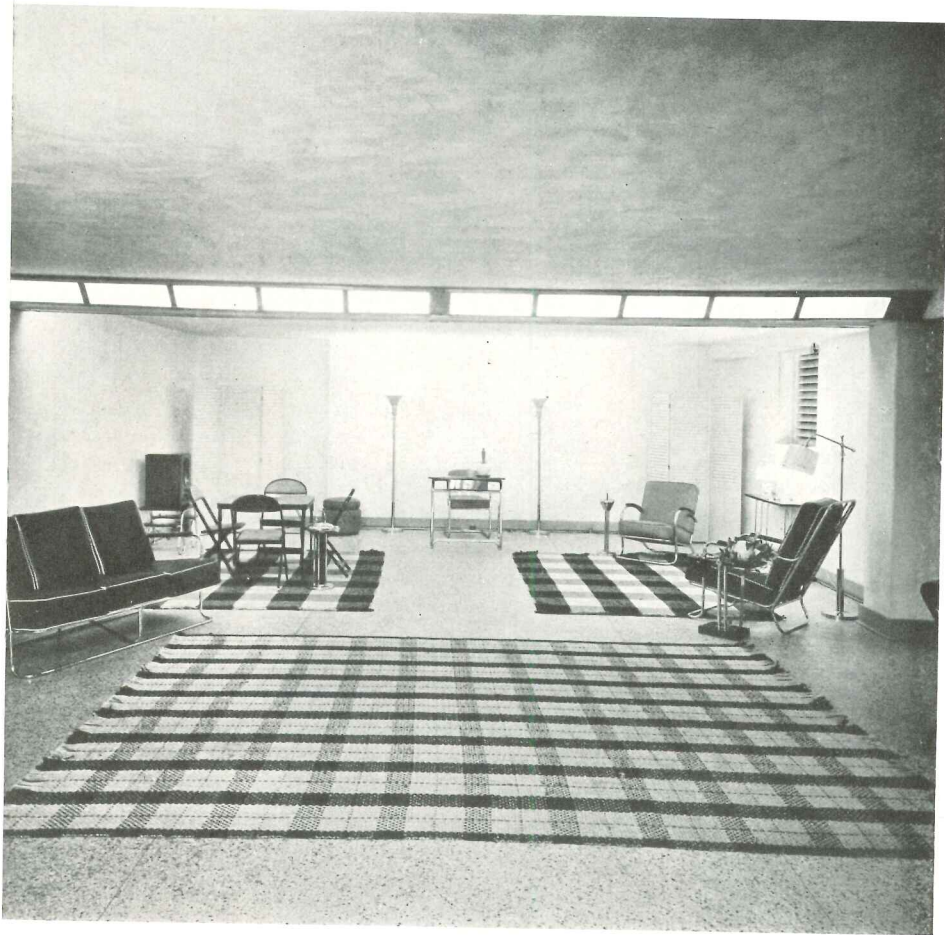

DISPLAY ROOM INTERIOR (A)

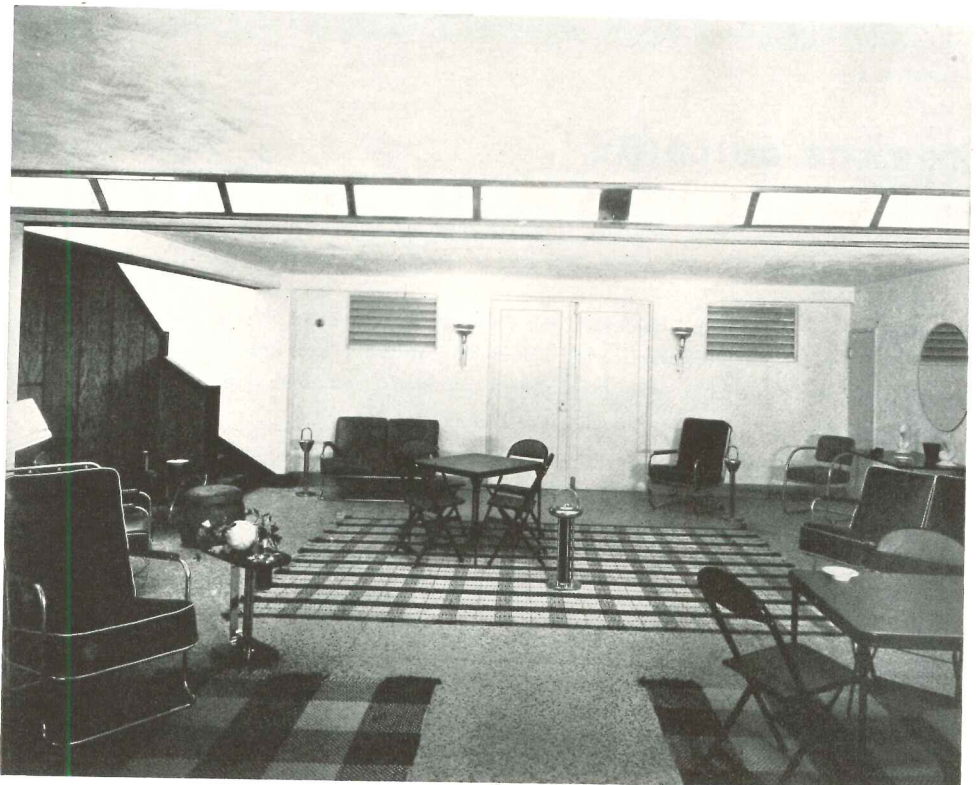

DISPLAY ROOM INTERIOR (B)



# STORAGE BUILDING



Photograph by Albert Rothschild

## STORAGE BUILDING

613 WEST 46 STREET, NEW YORK CITY  
MANOUG EXERJIAN, ARCHITECT

Originally a five-story "old-law" tenement, this building was converted into a two-story fireproof storage building. Minimum initial investment and upkeep dictated simplicity; the area in which the building is located dictated its type. It was leased before completion after many years of idleness.

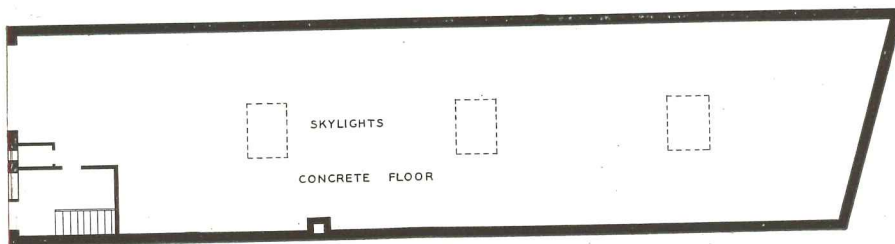

FLOOR PLAN

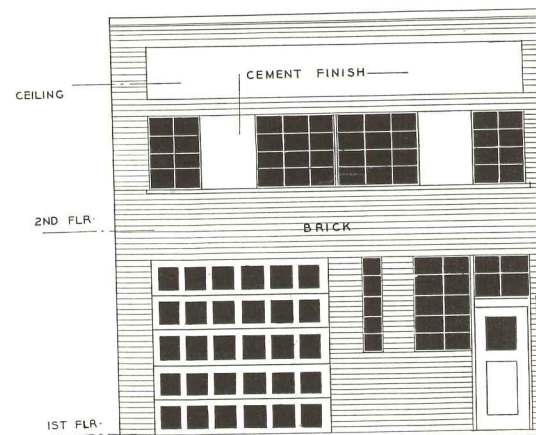

ELEVATION



# TECHNICAL NEWS AND RESEARCH

FEBRUARY 1937

**RADIOGRAPHY:** Developments of recent years have made the industrial use of X-rays a much simpler process than formerly. Portable machines of greater penetrative ability and photographic materials of greater sensitivity are both responsible to a large degree. As shown by various papers presented in a recent symposium on radiography and X-ray diffraction methods conducted by the American Society for Testing Materials (soon to appear in book form), there are an increasing number of applications in the building field as well as in the research laboratories.

The use of X-rays makes possible the non-destructive testing of structural materials and joints. Particularly is this important in casting and welding. Even with the improvements attained in welding technique during the past decade, major defects such as entrapped slag, cracks, porosity or incomplete fusion, may occur at any portion along the welded joint. The presence of such weld defects can be detected easily by radiography.

Herman E. Seemann of the Eastman Kodak research laboratories reports a case where X-rays were used to determine the permissible load of a concrete floor in a building whose blueprints and specifications had been lost. In another concrete building a cracked region was examined radiographically and the cause found to be faulty reinforcement. Rivets likewise can be inspected for defects.

Wood is relatively transparent to X-rays, and investigators have found that they can disclose such faults as knots, cavities, worm holes and metallic inclusions. Even live trees can be examined for evidence of decay or disease. The accompanying illustrations show how typical internal defects appear: (above) live borers in their subterranean galleries; (below) decay extending from a hole into the surrounding grain. (The radiograph is technically a "negative print"; in other words, thin parts of the specimen appear darker than the thick parts.)

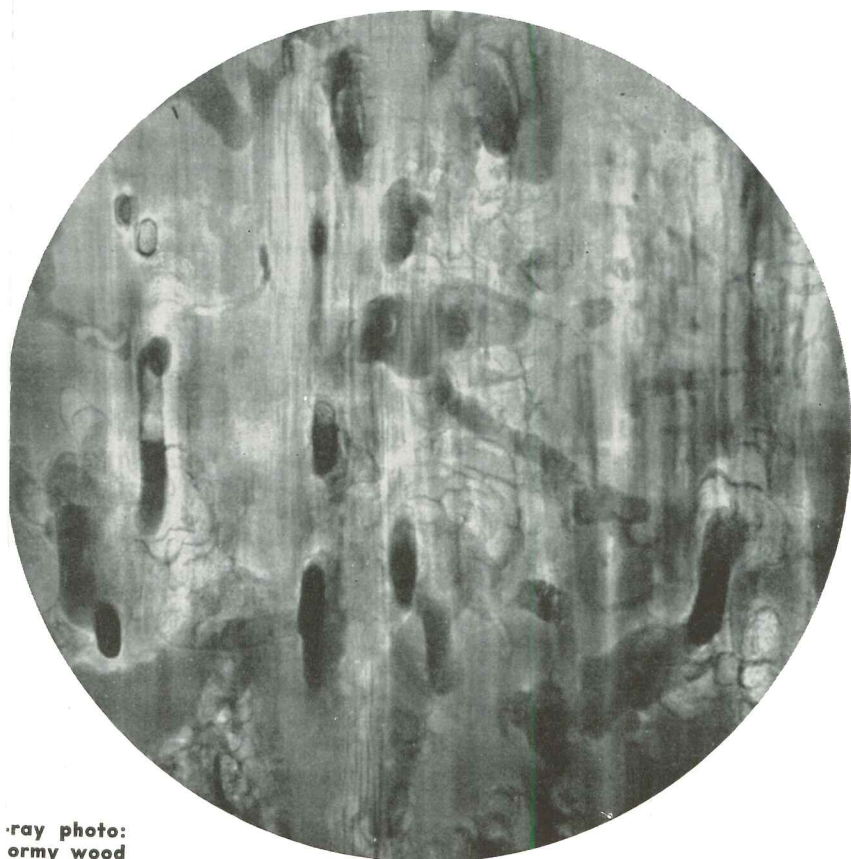

X-ray photo:  
wormy wood

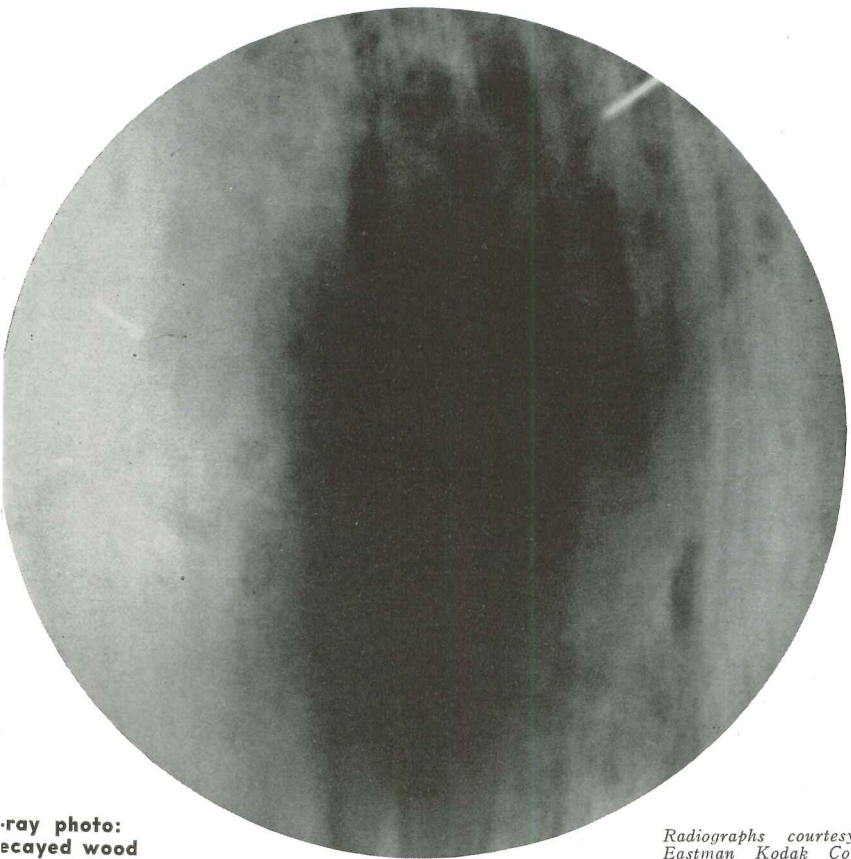

X-ray photo:  
decayed wood

*Radiographs courtesy  
Eastman Kodak Co.*



## PLYWOOD PREFABRICATION

Since 1935 the Haskelite Manufacturing Corporation, Chicago, has been experimenting with a structural system developed by George R. Meyercord, president. Prefabricated houses have been built, but general introduction in the low-cost field is not practicable as yet according to corporation officials. It is hoped that costs may be reduced; if so, further development work may be undertaken.

The units are designed for mass-production. They are of two kinds: (1) a plywood-pane unit made of five plies of 1/7-inch veneer cut into standard sizes, and (2) an I-beam made by welding back to back two sheet-steel channels cut to standard lengths. The edge of the plywood panels are grooved to receive the flanges of the I-beams. Two such panels with two of the I-beams are assembled into a box-like structure, the two panels forming its sides and the I-beams forming its edges, the ends of the box being open. Another box can be built upon the first one, one I-beam being common to both boxes. The I-beams and panels are held together by nails driven through the edges of the panels and through the flanges of the I-beams. In this way the I-beams serve as a means of fastening the panels together, edge to edge.

They also serve to stiffen the edge of the panels. The metal parts are not fastened together; in fact, they do not touch each other, always stopping short of the corner of the panels. They are held in correct relative position to each other only by the panels. The floors are made up of 9" I-beams with 2" flanges, and plywood panels 2 feet wide and of various lengths up to 10 feet. The walls are made of 4 5/16-inch I-beams with 2" flanges, and various lengths of plywood panels 3 feet wide. The ends of the box units are closed with half I-beams or channels nailed in place. Heat-insulation material is placed inside the sections having outside exposure.

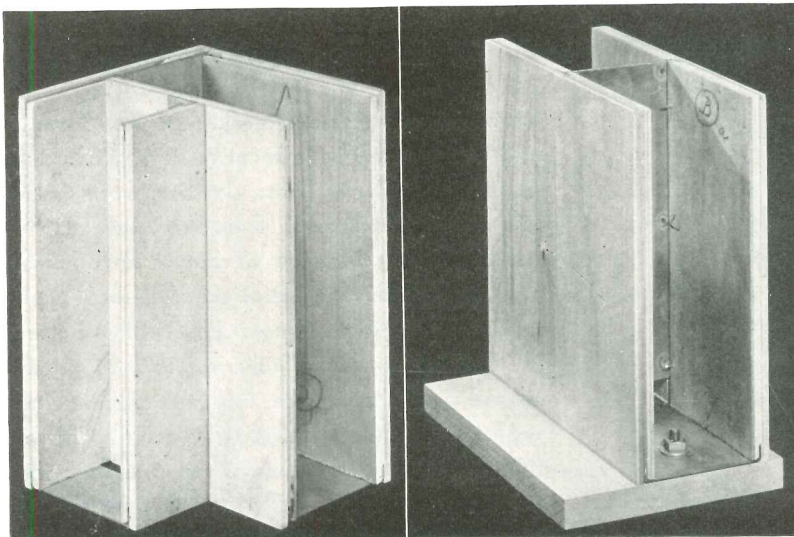
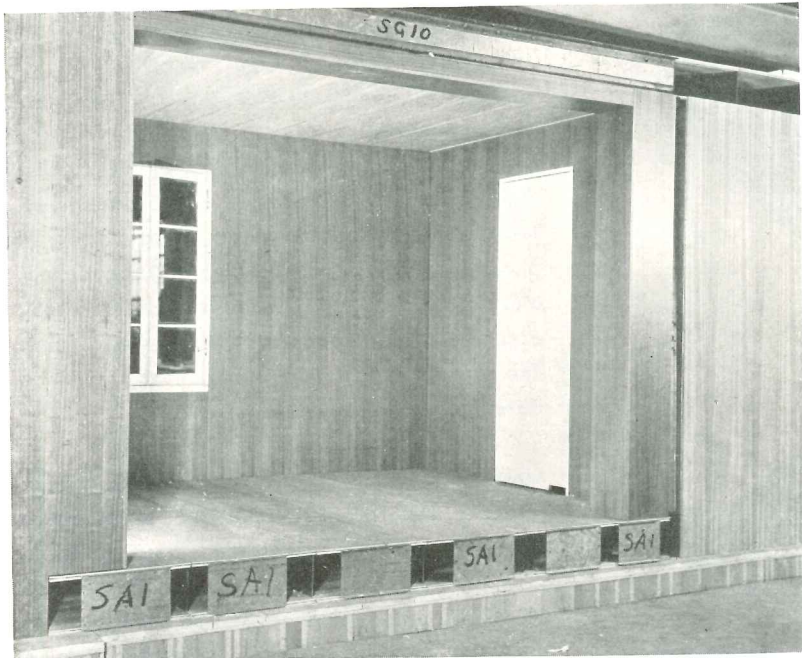
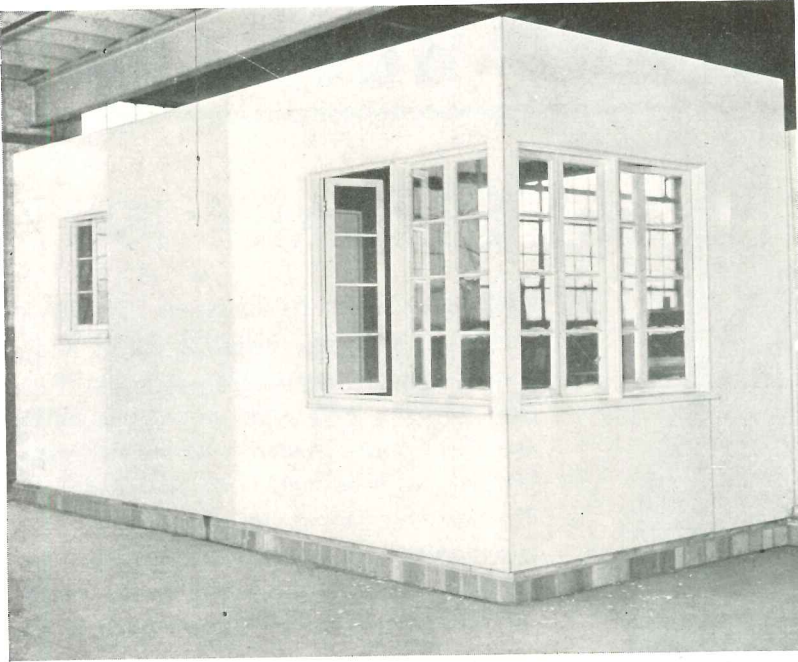

Central Film Service

The illustrations show (1) exterior view of plywood panel house, (2) assembly process, (3, 4) detail vertical corner, detail of wall joint.



# BUILDING IN PLYWOOD

A new material which has gone through some 30 years of development is described in the accompanying paragraphs by Thomas D. Perry of The Resinous Products & Chemical Co., Inc., Philadelphia. Mr. Perry is a pioneer in the use of plywood for house construction, having been chief engineer for Asper Houses (Jasper, Ind.) and consulting engineer for Gunnison Lagic Homes, Inc., (a new pre-fabricated house enterprise in Louisville, Ky., reported in *General News*, September 1936, page 174).

## WATERPROOF PLYWOOD FOR HOUSE CONSTRUCTION

Considerable attention has been focused on the practicability of transferring portions of hand-erection work from the field into the factory where modern machine manufacturing methods are available. There is, therefore, a strong tendency to shift building activity toward the use of more factory-made products and to reduce correspondingly the amount of field assembly work.

It should be admitted frankly that the transfer of operations from field to factory, without change or modifications, is not justifiable. Improvement must be made in the quality and serviceability of the product in order to make the change defensible. Nor should the shift be made for the purpose of reducing employment, but rather for the improvement of house-building. The trend is far reaching; the problem is how to interpret it intelligently.

Research has shown modern plywood to be a practical material for low-cost housing. It comes in large sheets, is easily worked, may be attractively finished and is moderately priced. Plywood glued to studding or joists results in "hollow-beam" construction, permitting the use of smaller joists and studs than otherwise allowable. Plywood is light to handle for erection crews and can be worked with ordinary carpenter's tools.

*Plywood characteristics:* Plywood is practically sheet lumber, since it consists of sheets of relatively thin veneers, peeled (in most instances) from a revolving log mounted in a lathe, and glued together with the grain direction of each layer at right angles to the adjacent layers on either side.

Advantages include—

- (1) Distribution of wood strength in all directions. (Solid wood is strong with the grain and weak across the grain.)
- (2) Nonsplittability.
- (3) Reduction of wood shrinkage and swelling to a minimum.
- (4) Increase of the strength/weight ratio several-fold.

*Waterproofness:* The hazard of water exposure has been up to the present time the most serious market handicap, and has been responsible for most public aversion to plywood products. A piece of furniture, after twenty years of satisfactory service, might be stored for a week in a damp room and be irreparably damaged. Rain coming in through an open window or a leaky roof might ruin a plywood-paneled room at any time. No known wood adhesive was really waterproof, consequently plywood was definitely barred from use in all weather-exposed uses and greatly limited in its applicability to semi-exposed (partially protected) work, such as partitions.

*Wood adhesives:* Animal (bone and hide) glues were undoubtedly the first and, together with fish glues, probably covered the wood adhesive field until the early decades of this century, when vegetable (casava), casein, albumin, sodium silicate, soy bean and other lesser known adhesives found their place in the wood-working program. The nearest approach to waterproofness, and hence durability, was albumin, coagulated under heat and pressure, but the mixture was hard to handle and difficult, if not impossible, to standardize. Casein with high lime content was the most practical approach to waterproof requirements, but could scarcely qualify as more than water-resistant.

The solution to this problem of waterproofness was the utilization of phenol-formaldehyde resins, but the development of a suitable type of resin in a practicable form has not been an easy matter. Careful studies have been made of phenol-formaldehyde resins in various forms: as solutions of still soluble and fusible resins; as aqueous dispersions of the resin in colloidal form; and as dry powder which could be applied to the wood without any solvent. As long ago as 1918 a waterproof bond was obtained in the form of a thin sheet of paper or other cellulose material impregnated with a phenol-formaldehyde resin, but only within the past 5 years can it be claimed that a phenol-formaldehyde resin has been applied on a sufficiently wide commercial basis to justify the statement that its bonding of veneer into plywood has been an industrial success. Millions of square feet of plywood using a resin film adhesive (*Tego*) are now being produced each month.

*Tego-bonded plywood:* The use of this sheeted resin imparts to plywood a number of properties that make it, in a sense, a different material. Naturally, the greater the number of plies and the thinner the veneers, the more a panel takes on the properties of the resin. The joint between two sheets of veneer is stronger than the wood itself and insoluble in water, as well as chemically inert and resistant to molds, fungi and bacteria. Fabrication is also speeded up.

Dry gluing in a hot press "irons" out the surface of the wood while wet glue "raises" the wood grain. While many plywood adhesives will deteriorate rapidly at 200°-250°F. these resin film bonded products hold their strength up to the point where the wood begins to char. Plywood made with the resin film can also be steamed to permit a wide range of curves and bends, which can then be "set" by the application of heat but with only enough pressure to make the curve or bend permanent.



## PLYWOOD PREFABRICATION

The Department of Housing Research, Purdue University, in collaboration with the Works Progress Administration and the Indiana State Planning Board, has built an experimental house in an effort to show that it is possible to replace slum properties with new construction if the cost is low enough to permit its rental at a profit. The 2-family unit (fabricated at Purdue University and erected on October 26 in one of the slum areas of Indianapolis) cost \$1,339, or \$669 per family, meeting the \$7 maximum monthly rental set for relief cases. Housing accommodations: combined kitchen and living room (12' x 16'); two bedrooms (each 8' x 8'); room with shower and toilet; cold running water; kitchen sink; cooking stove used for heating; sheltered porch.

Structural system: Fifty standardized plywood wall panels (4' x 8') and twelve roof panels (4' x 24') were used. In assembling the house  $\frac{3}{8}$ " steel rods, threaded at both ends, were run laterally through wall panels near top and bottom, and through roof panels at four equidistant points; nuts were then tightened on the ends of these rods and the house bound into a single structural unit. Plywood panels: Crude jigs were made of the 2" x 4" and 2" x 6" framing members by nailing them to the shop floor, thus holding them in place while the phenol-resin plywood was being nailed and glued (with a waterproof glue) to one side. The panels were then lifted out of the jig, turned over and filled with rock wool. Plywood was then nailed and glued to the other side. The panel was later painted with a coat of aluminum paint.

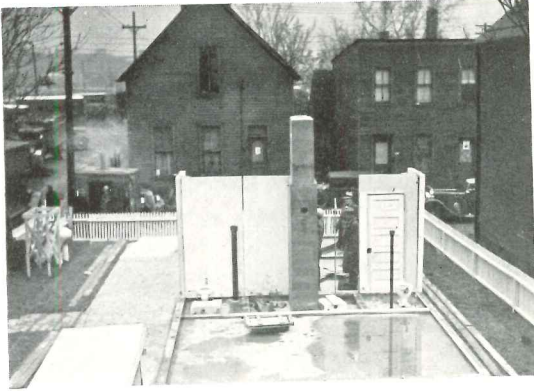

7 a.m.



7:35

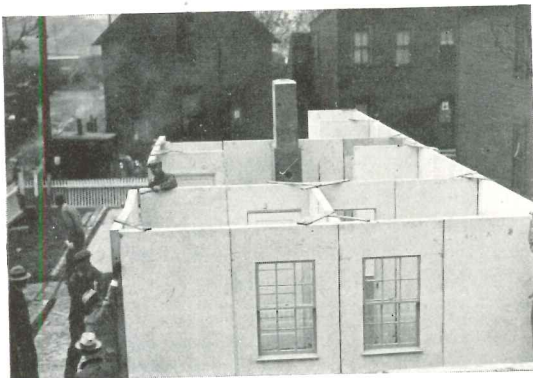

8:15



11:10



12:45

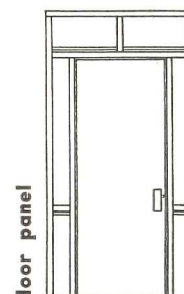
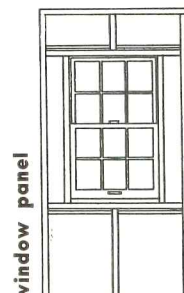
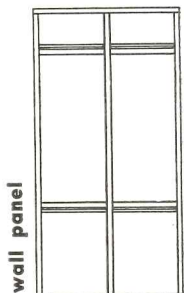
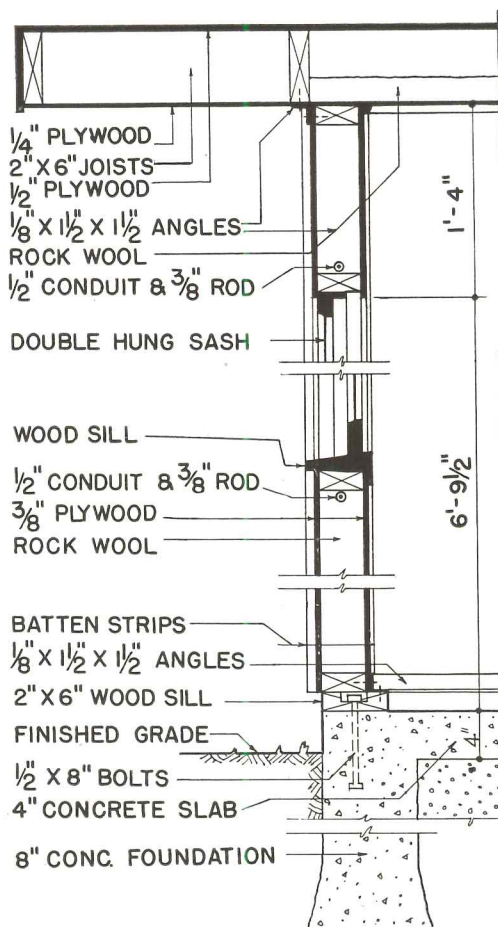



# BUILDING IN PLYWOOD

*In an effort to improve the quality of their product so as to compete with the synthetic resins, the plywood manufacturers have begun to use synthetic resinous bonding agents. This development of plywood is reviewed in the accompanying article, prepared by J. Delmonte, a technician who has been engaged in numerous tests on these products in the physical testing laboratory of the Naval Aircraft Factory in Philadelphia.*

## *Bibliography:*

- (1) *Baekeland and Thurlow—U. S. Patent 1,019,408: 1912.*
- (2) *U. S. Patent 1,299,747: 1919.*
- (3) *Phenolic Resin Adhesives in the Plywood Industry. Industrial and Engineering Chemistry, p. 1114, October 1935.*
- (4) *Molded Plastics in Wood Veneer. Modern Plastics, June 1935.*
- (5) *Laurite. Industrial and Engineering Chemistry, News Edition, p. 378, September 20, 1936.*

## NEW DEVELOPMENTS IN PLASTIC-BONDED PLYWOODS

As early as 1912, Dr. Baekeland, discoverer of the plastic material which bears his name ("Bakelite"), recognized the value of a waterproof bond to plywood. A process (1) was patented for applying the phenol-formaldehyde resin to the plywood in a solution of alcohol. Excessive staining and the expensive loss of solvents during the drying, which was preliminary to the curing, were the chief drawbacks to this method. The film glue method of McLain (2) supplanted the earlier direct solvent method; it was a less expensive procedure. By the impregnation of tissue paper with the resin, and the application of a paper sheet between the plies, bonding was achieved by heat and pressure. The paper was impregnated and the resin solvent recovered under controlled conditions. This method brought synthetic resin adhesives into actual commercial use in the plywood industry. There followed then a method of sprinkling dry powdered resin on the surfaces of the plies to be united, which were already moistened with alcohol; a fair degree of success was encountered with this method.

However, in all of these cases, the application of synthetic resins to plywood required an operation of intense heat and pressure in order to polymerize the resin into its final, infusible, solid form. This treatment is characteristic of the thermo-setting resins which have been proposed for plywood construction. (Phenol-formaldehyde and urea-formaldehyde are the two chief thermo-setting resins.) Consequently, means were sought to reduce in some measure the length of operation and the heat required for curing, by careful process control or by the addition of chemical catalysts. Likewise, in order to compete with the glue adhesives, the process had to be rendered as inexpensive as possible.

With this background in mind, we find that in recent years practical methods have been developed for forming plastic-bonded plywood, priced about the same as the casein-glued products. Sontag and Norton (3) have devised a method of applying the phenol-formaldehyde resin through the medium of a colloidal suspension of the adhesive in water, eliminating the organic solvent. The colloid is dehydrated at the factory and the plywood manufacturer buys a dry powder, which in turn is resuspended in water. The water is used to spread the resin adhesive over the surfaces of the plies and allowed to evaporate to a great extent. The plies are then placed together and the resin is cured at 300°F. for one minute, followed by longer periods at lower temperatures. Suitable phenol-formaldehyde

bonded plywood for structural and decorative purposes is thus produced economically.

Stout and Collins (4) indicate considerable success in the formation of phenol-formaldehyde bonded plywood by somewhat analogous methods, with the exception that the resin is sprayed in an organic solvent solution. This method entails a loss of solvent (acetone is used), but an attempt is made to keep it to a minimum. About 10 square yards of coverage are claimed for one pound of resin. The plywood and resinous layers are then cured for six minutes at 325-350°F. under 2,000 pounds pressure. The phenol-formaldehyde bonded resin was 8 times as resistant to warping and peeling as the glued plywood!

Of course, the high temperatures involved leave the plywood in a bone-dry condition, susceptible to uneven moisture absorption and possible cracking or distortion. A controlled procedure of reapplying moisture after curing insures greater uniformity.

Other manufacturers have turned to urea-formaldehyde as a suitable resin for bonding the plywood layers. Although urea-formaldehyde is a little more expensive than the phenol-formaldehyde, Dike (5) reports advantages in using this resin that merit careful consideration. Normally, urea-formaldehyde requires about the same heat treatment and pressure as does the phenol-formaldehyde, but the addition of certain catalysts has produced noteworthy results.

Thus, there appeared on the market very recently a zinc-chloride-urea-formaldehyde synthetic resin (*Laurite*) which differed considerably from the basic urea resins, to the better advantage of plywood construction. In the unpolymerized state, the new resin is water soluble, yet stable in a dry state. It possesses a high heat sensitivity and a temperature of 220°F. is required for curing. Like the phenol-formaldehyde resins, it is unaffected by moisture. It is colorless and cannot stain the wood or show through thin plies. In addition, in the dry bond, it is stronger than wood, with the result that in dry shear tests of bonded specimens, failure occurs usually in the wood.

The superior strength of the resinous layers to the plywood is not characteristic of glued plywood, and greater advantages lie in a waterproof bond. It is with great interest, therefore, that American designers may view the appearance of this new superplywood which is not limited in quality by the inherent characteristics of the glued interfaces. One can venture to predict that the building field will hear much more about synthetic resins, for they promise to be a valuable addition to the list of materials.



# RESEARCH IN WOOD

*Although wood is remarkable among natural organic materials in exhibiting a minimum shrinkage and swelling, these dimensional changes are sufficiently great to introduce difficulties and even limitations in its use. Since nature has already minimized the shrinking and swelling to a large extent, the problem of further diminishing such changes is extremely difficult. By controlling the moisture absorption of wood, however, fluctuations in size can be prevented. Research in this direction has been under way at the Forest Products Laboratory, Forest Service, U.S. Dept. of Agriculture (maintained at Madison, Wis., in cooperation with the University of Wisconsin). These investigations are described in the accompanying article by Alfred J. Stamm, senior chemist.*

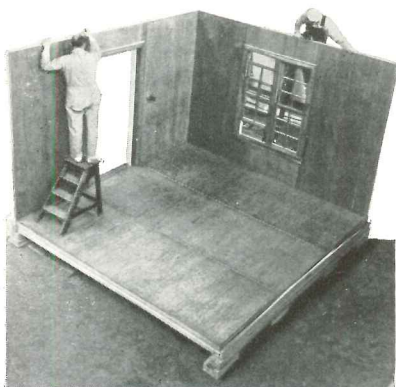

In 1935 the Forest Products Laboratory began to develop a system of prefabricated panel units utilizing plywood. (See reports in earlier issues; August 1935, pages 102-106; July 1936, pages 72, 73.) Research is continuing on details for a full-size house, covering such problems as fire resistance, insulation, moisture movement in walls, exterior finishes, and the effect of cut-outs on the strength of floor panels.

## CONTROLLING THE SHRINKING AND SWELLING OF WOOD

Most of the efforts of the Forest Products Laboratory to minimize the shrinking and swelling of wood have been extended in developing surface coatings that are as impermeable as possible to water, thus mechanically blocking the coming and going of moisture which is directly responsible for the dimensional changes. Considerable success has been met. Coatings have been developed that show moisture-excluding efficiencies as high as 98% as compared with unprotected controls when alternately exposed to relative humidities of 95 to 100 per cent for two weeks, 60 per cent for two weeks and weather exposure for six weeks, for periods of more than a year. These coatings consist of aluminum leaf between coats of other materials, such as paints or varnishes. Coatings of varnish, enamel, or paint containing aluminum powder give moisture-excluding efficiencies of 90% and better under similar exposures. Bituminous paints, granular pigment paints, and spar varnish, as well as synthetic resin varnishes, all show efficiencies between 50 and 90% when a number of coats are applied.

In order to get this protection against moisture, all surfaces of the wood must be completely enveloped with the coating. A break at any point will appreciably decrease the efficiency. In construction work the application of complete coatings on all surfaces after assembly is almost impossible. The use of precoated material of the required dimensions would appear to be the solution of the problem but even here the envelop is broken to some extent on nailing. Surface coatings further give only temporary protection where the material is subject to abrasion, as in the case of floors and window casings. Then, too, the exposure of the coated wood to prolonged low and high relative humidities, such as in northern climates where the houses are heated for practically half of the year, cuts down the moisture-excluding efficiency. (Any protection which merely cuts down the rate of absorption of moisture naturally will show up to best advantage when atmospheric conditions are changing more rapidly than the material can take up or give off moisture.)

Although surface coatings are of extreme value, it is obvious that they do not offer an entire solution of the problem. For this reason a treatment of the wood was sought that would actually cut down the affinity of wood for water and thus permanently reduce the moisture absorption and make possible cutting, nailing and abrasion without loss of moisture-excluding efficiency.

Preliminary studies showed that depositing of waxes and resins in the same struc-

ture within the cell wall (where moisture is absorbed with accompanying swelling) materially reduces the original shrinkage but does not prevent moisture from ultimately being absorbed and swelling occurring beyond the original green dimensions of the wood. Even though the waxes and resins in themselves are highly water-resistant, water works its way between the internal wax films and wood. Although the treatment appreciably reduces the rate of take-up of water, the amount finally taken up is not affected. It was obvious that a treating material would have to be used that would actually bond to the wood. Materials that have an affinity for wood, unfortunately, also have an affinity for water so that they would be of no value in excluding moisture. It thus is necessary in using such a wood-bonding material to convert it to a water-insoluble material after it has bonded to the wood. This is exactly what is done in the process of forming synthetic resins within the wood structure, recently developed by the Forest Products Laboratory.

The wood is treated with a mixture of phenol and formaldehyde, together with a catalyst dissolved either in water or wood alcohol. In case the wood is green the treatment consists in soaking the wood in the solution at room temperature sufficiently long for the solution to diffuse into the entire fine structure of the wood, or, in the case of air-dried wood (4 to 15% moisture), the diffusion part of the treatment can be advantageously preceded by an impregnation of the coarse capillary structure by placing the wood in a treating cylinder, evacuating, running the solution into the cylinder so as to immerse completely the wood and then applying a pressure. This preliminary treatment is advantageous only in the event the lengths of the wood specimens in the fiber direction are not great and the species are among those easily treated, as penetration is almost entirely in the fiber direction.

The phenol-formaldehyde solution has a great affinity for wood, as is shown by the fact that the wood swells more in it than in water alone. After standing in the solution a sufficient time to allow the resin-forming solution to diffuse into the cell walls, the wood is slowly dried so that further diffusion of the resin-forming materials into the cell walls accompanies the removal of solvent. The wood is then cured at about the boiling point of water. This heat treatment causes the phenol and the formaldehyde to react to form a resin which is water-insoluble. The moisture-excluding efficiency obtained appears to be permanent and the wood can be cut and nailed without affecting



it. This efficiency increases with the concentration of phenol and formaldehyde used up to a maximum value of about 70% for a single treatment, and can be somewhat augmented by multiple treatments. The amount of resin necessary to give a moisture-excluding efficiency of 70% will vary with the species and density of the wood, ranging from about 30 to 50% of the weight of the wood. Efficiencies as high as 50% have been obtained with as little as 15% increase in the weight of the wood.

Not only is the swelling and shrinking of wood permanently reduced by this treatment, but the mechanical properties are improved as well. The hardness and the compressive strength at the proportional limit perpendicular to the grain are increased considerably. Maple containing about 20% of its weight of resin gave increases of over 50% in each of these properties. Compressive strength parallel to the grain is increased somewhat less, and static bending properties and toughness are not affected.

Gluing tests showed that the treated wood can be satisfactorily glued with animal or casein glues. Excellent results were obtained with Bakelite glues, using the hot-press but not the cold-press technic. Plywood glued with phenol-resin film or with casein glue was successfully treated with the synthetic resin without affecting the joints.

The present limitations of this process are the size of specimen and species that can be treated and the cost of treatment. Not all woods can be successfully treated because of the difficulty of getting the treating material distributed throughout the structure. A number of softwoods, the sapwood of a

number of hardwoods, and the heartwood of the softer hardwoods have been successfully treated in specimens 14 by 4 by 1 inch in size. The largest specimen successfully treated to date is 30 inches long by 5 by 5 inches. Larger specimens of the more readily treated species could undoubtedly be treated but the treatment would take prohibitive lengths of time.

On the basis of the complete treatment of the wood the cost would be about 40 cents per board foot. This figure is at least ten times the cost that could economically be added to millwork to minimize the dimension changes. Even at present costs the treatment might, however, be economically applied to such specialties as lithograph backings, shoe lasts, shuttles, wood bearings, small handles, and athletic goods.

As the cost of the treating process is mostly that of chemicals, there are possibilities of cutting costs by further reducing the amount of chemical needed. Although attempts are now being made to do this, theoretical considerations indicate that the probability of going far in this direction is small. In this age of synthetic resins it is quite possible that the cost of the raw materials will be considerably reduced. Then, too, there is the possibility of treating only the outer 1/16 to 1/8 inch of large specimens; however, this eliminates the advantages of the process over other coatings.

The process is thus of practical value at the present time only in specialty fields. Research is being continued, and with the aid of the fundamental information gained to date, it is hoped that further efforts will yield results of more widespread use.

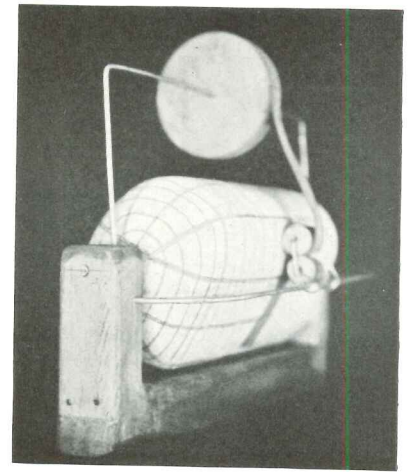

This model illustrates a "cocoon" system of construction devised by Corwin Willson of Flint, Mich., for his Mobile House (reported July 1936, pages 64, 65). On a collapsible rotating form, inflated to the desired shape, a traveling carriage winds tightly a multiple helix of various materials which make a curvilinear wall about 1/2" thick. The frame is integral with the stressed skin covering; inner and outer "skins" of 1/8" flexible plywood have overlapping deformed joints (bonded under heat and pressure) which come together to build up continuous "ribs" with intervening air spaces inside the wall. The plywood is made in rolls (12" to 16" wide) instead of panels, and the plies cross diagonally in such a way that all grain runs lengthwise between the built-up ribs. . . . A producing company has been formed and work started on an experimental full-size model.

## PLASTIC MADE FROM SAWDUST: Forest Products Laboratory

After almost 100 years of research, the chemical nature of lignin—the substance which cements together the tree or plant cells and also reinforces the cellulose within the cell—still is a matter of controversy. One of its known properties, however, is the ability to polymerize easily and to combine with other organic compounds to form resinous or plastic material.

Readily available as raw material for the production of lignin plastic is the nation's supply of sawdust which runs into millions of tons, much of it now wasted or used for fuel or other minor purposes. As part of its research program, the Forest Products Laboratory is exploring this possibility and has succeeded in developing a plastic from sawdust. The work is still in an experimental stage and some further refinements in the product are necessary. Laboratory officials express themselves as convinced,

however, that the plastic can be perfected to a point where it can successfully compete with other plastics on the market.

Simple hydrolysis of sawdust with dilute acid at the proper temperature and pressure is sufficient to produce a powder which will mold to a hard, black, dense material not far different from other well-known molding materials at only a fraction of their cost. Incorporating 6 to 8% aniline and 6 to 8% furfural in the mixture before pressing yields a much better material. This plastic is easier to mold, and can be pressed at a much lower temperature. It has a machinability much like hard rubber. A third modification is made by digesting sawdust with aniline and compounding the finished material with furfural. This product has a better finish but appears to be somewhat weaker; it is strong enough for purposes for which plastics are generally used.



# EQUIPMENT FOR WINDOWS

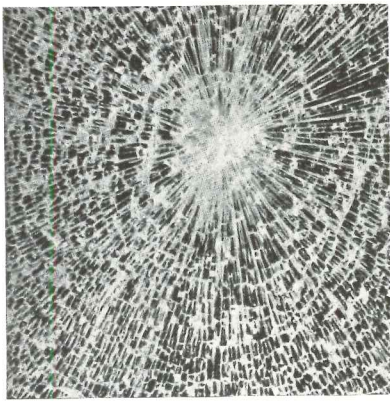

Tuf-flex at the breaking point

## super-strength glass in colors

The strength and other structural advantages of clear Tuf-flex are combined with a wide range of colors in a new product called "Enameled Tuf-flex," announced by Libbey-Owens-Ford Glass Company, Toledo. Intended for building facades, signs and other luminous design elements subject to extreme variations in temperature.

Tuf-flex is made by reheating a light of regular plate glass (maximum size: 48" x 48") almost to softening point and then suddenly cooling the surfaces with blasts of cold air. A strained condition results which makes the glass 3 to 7 times stronger and 3 times more resistant to thermal shock. If broken, it disintegrates into small fragments resembling bath salts. Glass enamel is now fused to the surface as an integral and translucent part of the light of glass. With properly built-in lighting the entire surface becomes evenly luminous.

## one-hand controlled windows

Originating in Scotland and manufactured for the European market since 1930, the Young constant balance window fittings are now being produced in this country by Young Windows of America (570 Seventh Avenue, New York). So far these windows have been installed chiefly in automobiles, trailers, trains, ships (the Queen Mary), but according to the manufacturer they are also applicable to building design.

The constant balance fittings, which embody a system of cam compensation, are adaptable to any standard window. With a screw driver the balance can be adjusted until the effort required to raise or lower the window is equalized. Once installed, a slight pressure up or down moves the window into the position desired. There are no operating levers or cranks. The fittings are watertight and stickproof against dust or grit. The constant pressure holds the window rigid in its frame so it cannot rattle or shift from the desired position because of vibration. All mechanism is concealed by the wall pocket into which the window sash slides.

## plastic sheets for windows

"Plexiglas," a thermoplastic produced by Röhm & Haas Company (222 West Washington Square, Philadelphia), offers qualities which have led to its use in the construction of transport vehicles. The windows in the dining room of the zeppelin "Von Hindenburg," for instance, are made of this material; so also are the transparent curved hoods in the new passenger planes, giving the pilots an unimpaired view in all directions. As yet the product has not been used

in the building field, but its properties indicate that it may be suitable for windows particularly curved surfaces.

Plexiglas, a polymerized derivative of acrylic acid, is a colorless, transparent thermoplastic solid which shows no change of properties upon aging. It looks very much like ordinary silicate glass. Since it can be bent or formed into various shapes without developing any stains or blemishes and also is practically unbreakable when used in  $\frac{1}{4}$ " thickness, it has many uses for which silicate glass would not be practical. As an organic resin, it exhibits great stability to weathering; it is not affected by water, hydrochloric acids, or oils. It transmits ultraviolet and is not affected by sunlight. Light transmission: 94-94.5%. Low specific gravity: 1.18. Tensile strength: 7,000-10,000 lb./sq. in. Flexural strength: 11,700-14,000 lb./sq. in. Impact resistance: 2-3 ft lb./sq. in. It does not ignite readily but will burn slowly after having been warmed and ignited by a flame. Plane sheets may be bent readily by warming to 90°-125°C. Because of a rather high coefficient of expansion the sheets are best installed in rubber channels rather than in rigid frames with screws.

## electric screens for flies

Flies attempting to enter the milkhouse or other buildings on the Rural Electrification Administration's electrified farm near Herndon, Va., are killed automatically by means of electric screens placed on doors, windows, and light traps. Screens were supplied by National Electric Screen Co., Chicago.

The screen is composed of parallel wires placed about one-half inch apart and insulated from the wood frame by means of porcelain or some other insulating material. (Wire bars of  $\frac{1}{8}$ " diameter are used on door screens to give the parallel wire rigidity.) Alternate wires are energized through connections with a lead attached to a small step-up transformer which increases the voltage to about 1,450 volts and minimizes the current to a few milliamperes.

Operation: Current flows only when insect attempts to enter the screen. A high voltage potential, existing at all times between two adjacent wires, causes an electric arc to be set up when an insect goes between the wires and "brakes down" the air resistance. The insect is thus burned by the electric arc and drops into a receptacle. The arc goes out immediately, and there is no current consumption until another insect contacts the wire or enters the electric field between the wires. Because of the low current, the screens are harmless except insofar as they may cause slight burns. They should be placed out of reach of children.



# EQUIPMENT FOR LIGHT, HEAT

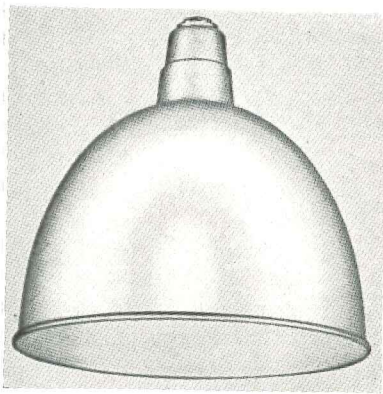

Westinghouse mercury reflector

## high mounting mercury reflectors

Units particularly suited for the general lighting of foundries, machine shops, power plants, receiving and shipping departments, and the like, are announced by the Westinghouse Electric and Manufacturing Company.

These reflectors, made from 14-gauge commercially pure aluminum sheets, are designed to distribute properly the light from the 400-watt high intensity mercury lamp where the mounting height is 18 feet or more. A special mogul type socket is rigidly mounted in the hood to position the lamp.

## 300-watt lamp made smaller

Introduced by Lamp Division, Westinghouse Electric and Manufacturing Company.

Increasing the illumination in certain industrial and commercial installations where 200-watt lamps are used presents a difficult problem because the standard 300-watt lamp, the next larger size, has a mogul instead of medium screw base and a greater over-all length. Sometimes a special 300-watt lamp with a medium screw skirted base can be used but more often it will not fit in inclosing globes and will protrude from open-type reflectors to cause glare and make matters worse. The only alternative has been to install new equipment. This is now merely a matter of lamp replacement because the new 300-watt lamp has a medium screw base and a light center length (6") the same as the regular 200-watt lamp. Although it will fit most 200-watt fixtures, the increased wattage may cause excessive surface brightness and make necessary a larger globe.

## luminous ceilings

A specialized lighting unit with an unusually large diffusing surface of extremely low brightness has been developed by Benjamin Electric Manufacturing Co., Des Plaines, Ill.

This fixture, called the Skylight, is designed to control and to minimize the intensity of specular reflection from shiny surfaces. In doing this it acts as a low-mounted luminous ceiling that not only reduces eye fatigue but facilitates the detection of minute surface imperfections or waviness in materials under inspection. Intended principally for industrial operations and inspection work, it can also be used in drafting rooms as a means of eliminating glaring reflections.

*Specifications:* The unit consists of a shallow porcelain reflector with a diffusing glass that covers the entire 28" x 36" opening. It is equipped with a centrally located twin socket taking lamps from 15 to 200 watts. A simple clamping arrangement allows fixtures to be coupled together along both the

28" and 36" sides. In this way as large an area as desired can be lighted by joining together as many units as required. Hand holes in the 28" ends permit easy relamping without removal of the diffusing cover glass; these hand holes are covered with sliding doors which can be opened by simply loosening a thumb screw.

## oil-burning water heater

A unit, complete with dome type heater, gravity oil burner, oil storage tank and controls, has been developed by American Radiator Company for automatically supplying domestic hot water at low cost to small houses, restaurants, barber shops, etc. It operates automatically or manually on low-priced range oil or distillate.

The aluminum painted dome type heater has a cast-iron water heating section, with a steel combustion chamber, insulated with rock wool. A special steel baffle in the top of the heater is designed to promote efficient operation by keeping the hot gases longer in the heater. There are no moving parts. The oil storage tank has a capacity of 8 gallons. For operation with the heater, a hot-water storage tank of 40-60-gallon size is recommended by the manufacturer.

## alcoholic steam radiator

Developed experimentally at the engineering laboratory of the General Electric Company, Schenectady, N. Y., to provide smoother control of radiator temperatures, particularly for use in air conditioning. Several heating units have been set up for field tests. None is on commercial sale as yet.

A "bottle" holding one or two pints of alcohol takes the place of the valve on an ordinary radiator. Steam is piped to the radiator in the usual way but does not enter the radiator or even the bottle. It merely heats the alcohol. Boiling easily, the alcoholic vapor takes up the entire heat of the steam and flows through the radiator as if it were real steam. As this vapor cools it condenses and runs as liquid, not back into the bottle, but into a small reservoir beneath the radiator. A thermostat controls this reservoir, so that the alcohol can turn into vapor and go back to the bottle for reheating when needed.

*Advantages:* There is complete elimination of radiator valves, no turning on or off of steam, no fluctuations in heat due to steam shut off. Radiator temperatures range from hottest steam down to those of hot water. With the alcohol bottle to do the "transfer," 250-pound steam can be piped with safety direct to radiators. It is now customary to use steam of lower pressures.



**new conception of lightning**

In the lightning investigations by General Electric research engineers (see report, *Technical News and Research*, March 1936, page 240), the objective has been to determine the characteristics of direct stroke lightning. Such knowledge is necessary since the calculation of what happens either at a point struck on a transmission line, or at more remote points where apparatus may be located, will depend upon the assumption made for the stroke itself.

Results seem to indicate that the cloud-to-earth path may not be considered as a conductor closing the circuit between the charged cloud and earth. Instead, the conception is of a streamer approaching the ground, carrying with it charges, and distributing along its path other charges. When this streamer, or leader, moving at a fractional part of the speed of light, approaches within a few hundred feet of the earth, induced charges in the earth of opposite polarity move into the structure which is going to be struck, constituting a current flow. At the moment of contact with either the earth or a streamer from the earth, the maximum current is reached. Current continues to flow into the stroke channel as long as sufficient difference in potential or separation of charge exists. Such a conception indicates that the magnitude of the current in the so-called main stroke will be greatest at the surface of the earth, and there is some evidence to bear this out.

Some discharges have streamers which approach the earth but do not reach it. On the earth, there will be a distribution of charges corresponding to those induced not only by the main stroke (see illustration) but also by the streamers. This stress may be high enough to produce streamers, not only at the point struck, but also at points under streamers approaching the earth. No streamers could have been noted visually from the object struck just prior to the stroke, because the time interval is so short as to make streamer and stroke appear simultaneously.

**"pipe-line" telephone system**

The first public test was made recently of a new transmission system being developed by Bell Laboratories. Conversations were held over the coaxial cable which has been installed between New York and Philadelphia.

Instead of the bundle of paper insulated wires which form the core of the ordinary telephone cable, the coaxial cable contains only a pair of copper tubes each the size of an ordinary lead pencil. Inside each tube is a wire, held centrally by thin discs of hard rubber. The system transmits a very wide range of frequencies—equivalent to the 1,000,000 cycle band assigned to all broadcasting stations—which can be split up into separate "bands." These bands provide 240 "two-way" talking circuits in each coaxial "pipe." The cable is significant also for the part it is playing in the development of television networks. (see report, *Technical News and Research*, December 1936, pages 474, 475).



lightning stroke with streamers from both sky and ground. (G. E. photo)

*ACOUSTICAL DEFINITIONS:* In an effort to eliminate confusion in the movie, radio and building fields and to provide musicians, scientists, engineers, architects and manufacturers with a common vocabulary that will permit them all to work collectively, the American Standards Association has set up at last, after 4 years of development, a standard "Acoustical Terminology." "Noise" is now classified as an undesired sound; "unpitched sound" replaces the original concept of noise. A bulletin containing the standard definitions is obtainable at 25 cents from the A. S. A., 29 West 39 Street, New York.

*ENAMELING DEFINITIONS:* With enameling branching out into new fields, more and more original terms are creeping into the enameler's vocabulary. Many new words have been coined by this industry. Realizing the need for clarification, the Ferro Enamel Corporation of Cleveland has just compiled an "Enameler's Dictionary," vest-pocket size.

*EXPANSION OF ROCKS:* About 100 typical American rocks of the type commonly used for building purposes have been studied and their coefficients of linear thermal expansion listed in a 36-page illustrated bulletin prepared by John H. Griffith and obtainable free of charge upon request to the Director, Iowa Engineering Experiment Station, Iowa State College, Ames, Iowa. For silica-bearing rocks, the expansions appeared to be dependent upon the amounts of free silica in the rocks, those with the maximum of free silica expanding the most.

Other new industrial developments and products are reported in the *Marketing News* section, beginning on page 36 in the advertising folio.



# BUILDING TYPES

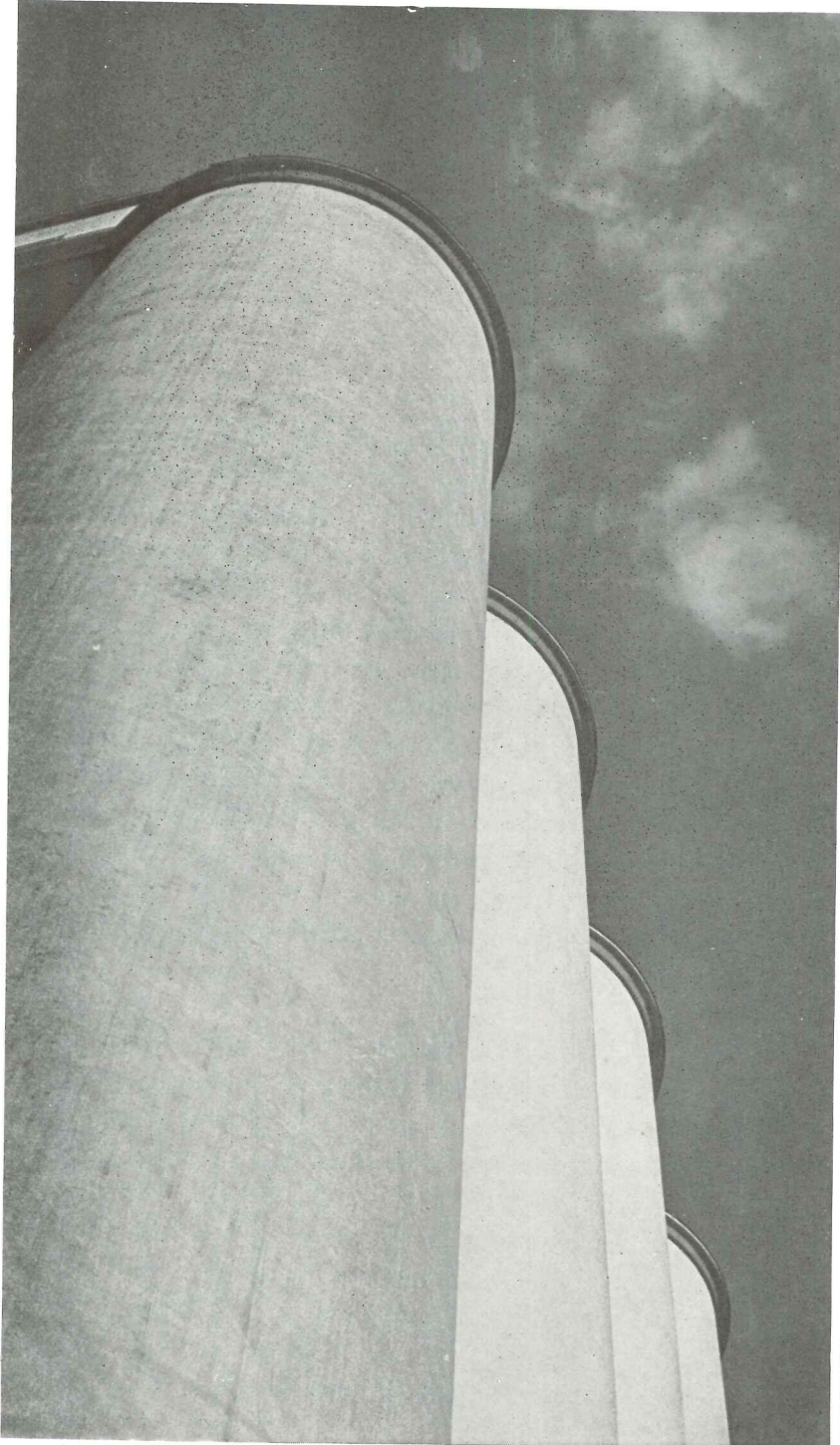

Photograph by V. G. Jurgell

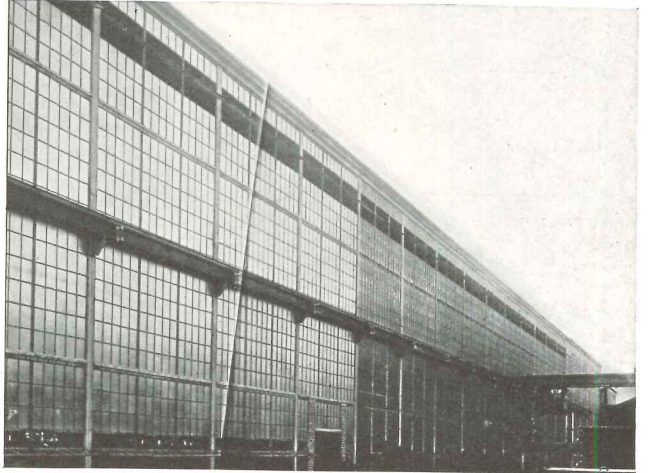
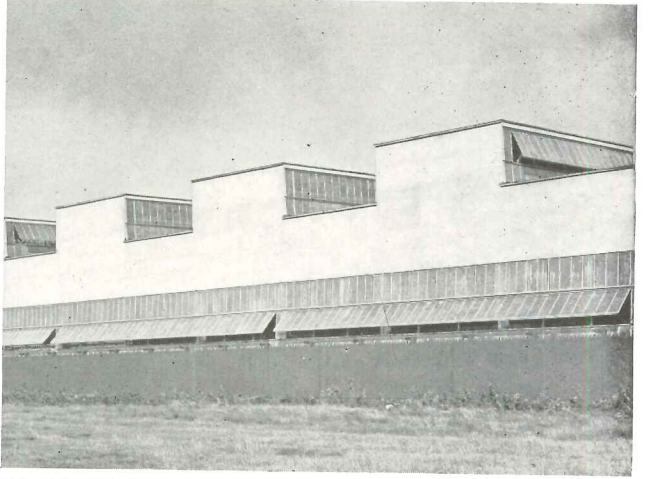
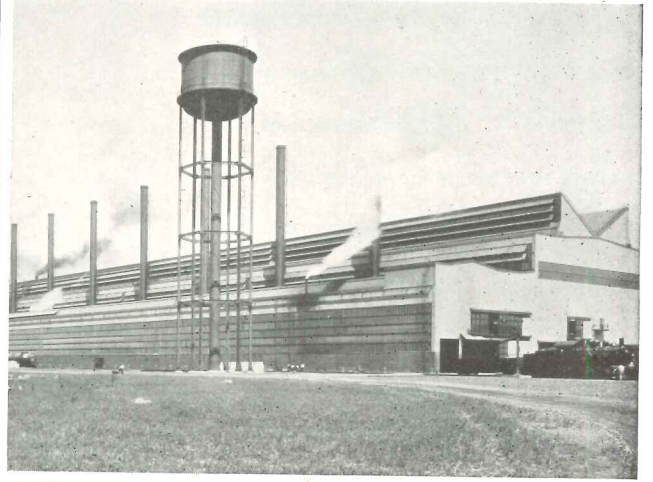

Fenestra

# INDUSTRIAL ARCHITECTURE

• SITE • LAYOUT • CONSTRUCTION • SERVICES • MATERIALS •



**FACTORY BUILDING IN 37 EASTERN STATES**  
ARRANGED AND RANKED BY DODGE DISTRICTS

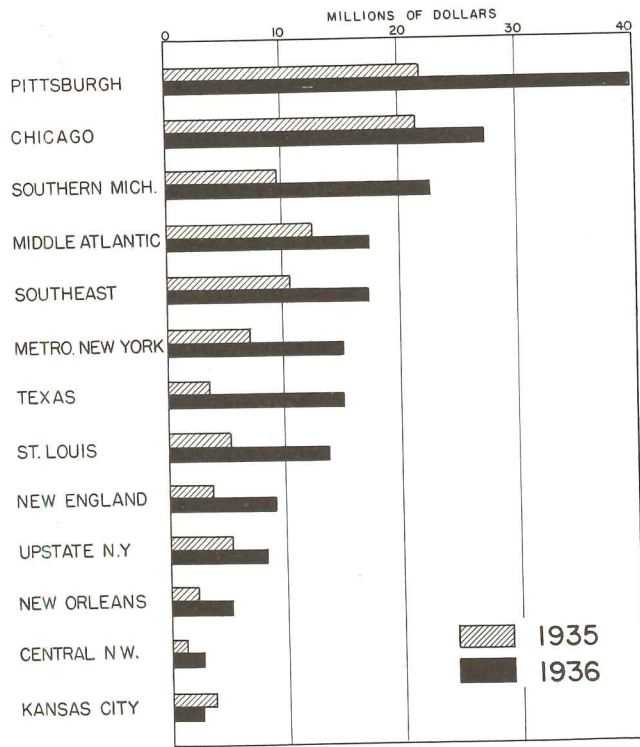

The above chart, besides showing the physical volume of factory building by geographic areas, pictures the relative importance of each area and the shifts in importance which have occurred since 1935.

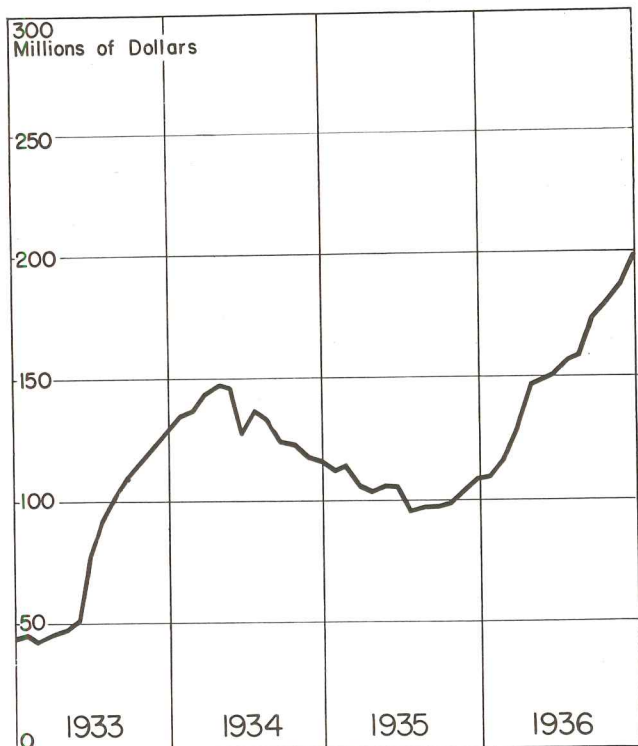

This is a 12-month moving total chart for factory building in the 37 eastern states. The sharp rise in 1933 was almost entirely due to brewery and distillery building operations consequent upon prohibition repeal. This influence removed, factory building settled down until 1935, when rapidly expanding industrial production, generally, laid the foundation for a sustained recovery in factory construction.

# INDUSTRIAL RECOVERY MEANS MORE FACTORY BUILDING

By L. SETH SCHNITMAN  
Chief Statistician, F. W. Dodge Corporation

Factory building is gaining stride. Not since 1930 has this class of construction been so active as it is today. And it is probable that 1937 will show a volume of factory building which will eclipse every other year since 1929. This is the record and the promise that is written large in the story of industrial recovery. No one industry, no one geographic area, no one structural type was responsible for the favorable showing in 1936 and in these respects 1937 promises to out-perform 1936 results. The largest arithmetic gains over 1935 occurred in the building of food product factories but the greatest percentage improvement centered in petroleum and textile plant. Substantial building increases, too, were recorded for paper and pulp, vehicles, printing and binding, and chemical plants.

By far the greatest volume of factory building in 1936 occurred in the Pittsburgh area—the industrial states of Ohio, West Virginia, Kentucky and Western Pennsylvania. This was quite natural, with all of the industrial gains there centered in the area where steel is king. But the most spectacular increases occurred in the Southwest, especially Texas, where petroleum dominates the industrial horizon. The southern peninsula of Michigan continues to reflect the mounting automotive demands, with the result that factory building here, in 1936, not only more than doubled the 1935 total but advanced to third rank in territorial importance from fifth rank in 1935.

These are only a handful of the important developments of 1936. But it is from such facts that prospects can be rather safely projected, now that there is reasonable certainty of continued industrial expansion and rising national income.



WELLSBURY FLOUR MILLS  
MINNEAPOLIS, MINNESOTA

## THE DESIGN OF INDUSTRIAL BUILDINGS

PREPARED BY  
STAMO PAPADAKI



*Photograph by William Rittase*

**I**NDUSTRIAL ARCHITECTURE, like any true construction result, is an architecture meeting requirements. The producing and manufacturing of today, the strict reality of the process, the magnitude of the scale, which goes beyond man power, have been the causes for such buildings or groups of buildings which are worthy manifestations of our time.

Industrial architecture begins with the requirements of the process to be sheltered. This simple fact absolves such architecture from any of the ridiculousness that few domestic specimens have been able to escape. By giving shelter to the "work in progress" industrial architecture tries to place harmoniously machinery and men: it disposes the most heterogeneous elements, fixed and moving, all located in space;





1

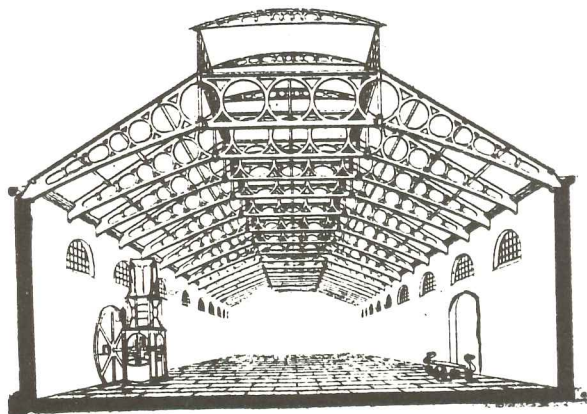

2

1 Monolithic concrete grain bins of the QUAKER OATS COMPANY, CEDAR RAPIDS, IOWA. R. O. Kirn, Engineer.  
2 ENGLISH MACHINE SHOP, 1833, an early structure designed for factory use.

and the resultant structure requires the significance of a machine itself.

Never before has architecture had to face so definite a problem and to realize itself not in a given form, not in a given scale, but as an organism which takes on its importance when it is in full function and uninterrupted movement. Thanks to mechanized production, architecture passes from a merely static problem in the act of conceiving living and growing organisms. The laws of gravity and the strength of materials, those ruling determinants of all genuine architecture of the past, became only the physical factors contributing to a solution which will depend purely on scheduled data.

What characterizes an industrial building is the flow of materials and the possibility of gradual extension. Instead of being a self-limited unit, as in most cases of a domestic or civic character, the plant is subject to future growth in order to meet new requirements of production and must also be adapted to the ever-changing design of the product. Therefore designing an industrial building is providing an *unobstructed way for the flow of a given volume of output with enough elasticity to permit a growth of the output, a redirection of the flow, or both*.

Moreover, industrial workers make up the greatest group in our mechanistic society. Consequently industrial architects dealing directly with their physical and spiritual welfare take on immediate importance in



only as relating to production, but also in a purely human and social sense. The housing of expensive and difficult-to-replace machinery is not the only impelling reason for the highest standards of safety and protection. Unhealthful conditions created by the industrial process itself or by inadequate buildings, poorly lighted working areas, or faulty ventilation, will cause an additional physical strain and consequently a material and human waste. Men as well as machinery produce under certain determined conditions. Their output is not unconditional but dependent upon definite laws. Therefore *the biological study has to conclude the engineering solution of the problem.*

It is long past the time when the factory is necessarily the gloomy part of our communities, a place of human contrition and a threat to the neighboring areas. The industrial slum gives way constantly to orderly units. In industry, we can say, already possesses the efficient building-tool for its own use and the proper language to express its needs. It has enveloped the factory with its attention; it has endowed it with the most efficacious elements, with the most appropriate materials; it has courageously undergone the expense of technical research and experimentation. Can we hope that industry will give us the same magnificent means without which the solution of a domestic and civil contemporaneous architecture is inaccessible?

Water tower and tanks of the LEVER BROTHERS PLANT AT EDGEWATER, NEW JERSEY. Designed by Stone and Webster.

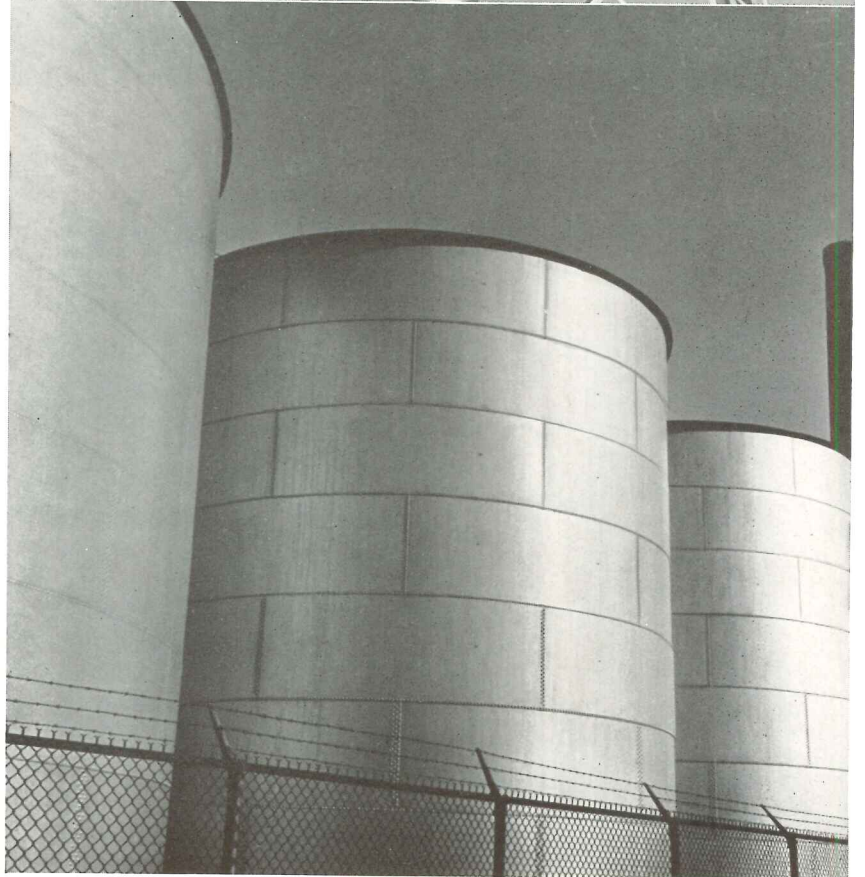
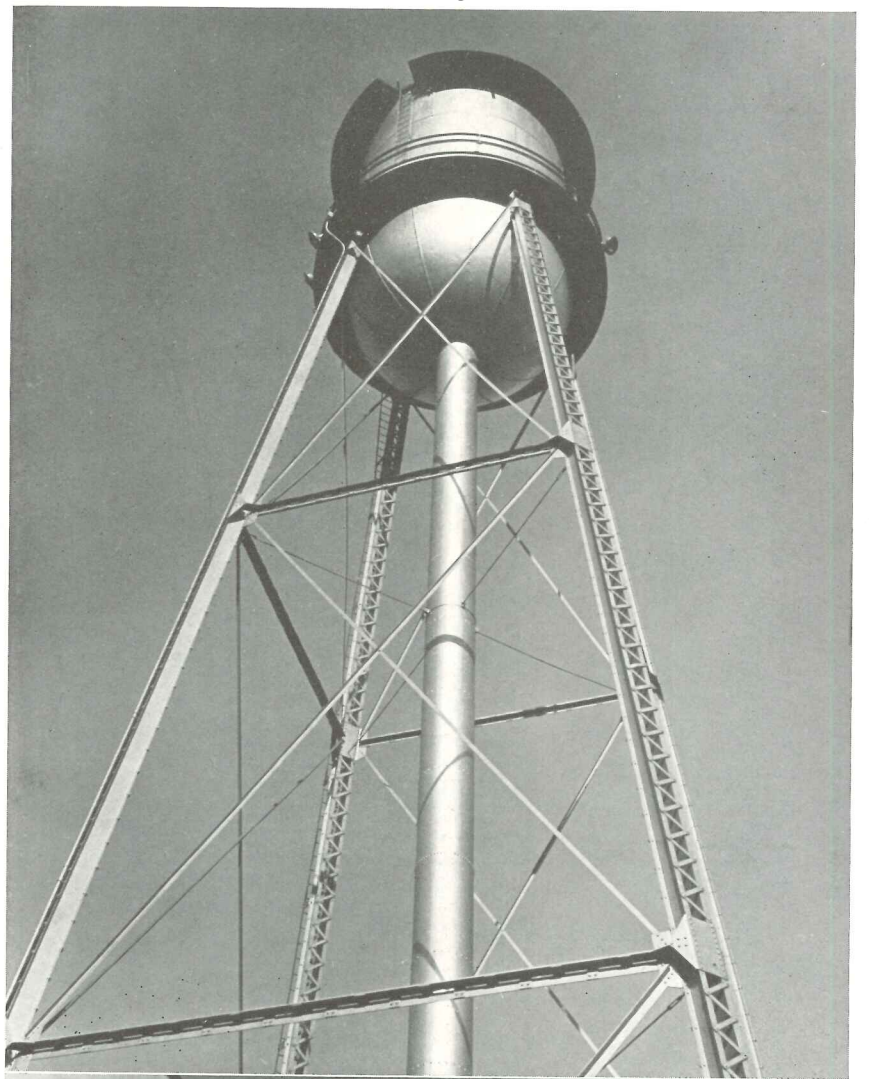

Photographs by Max Zimmerman



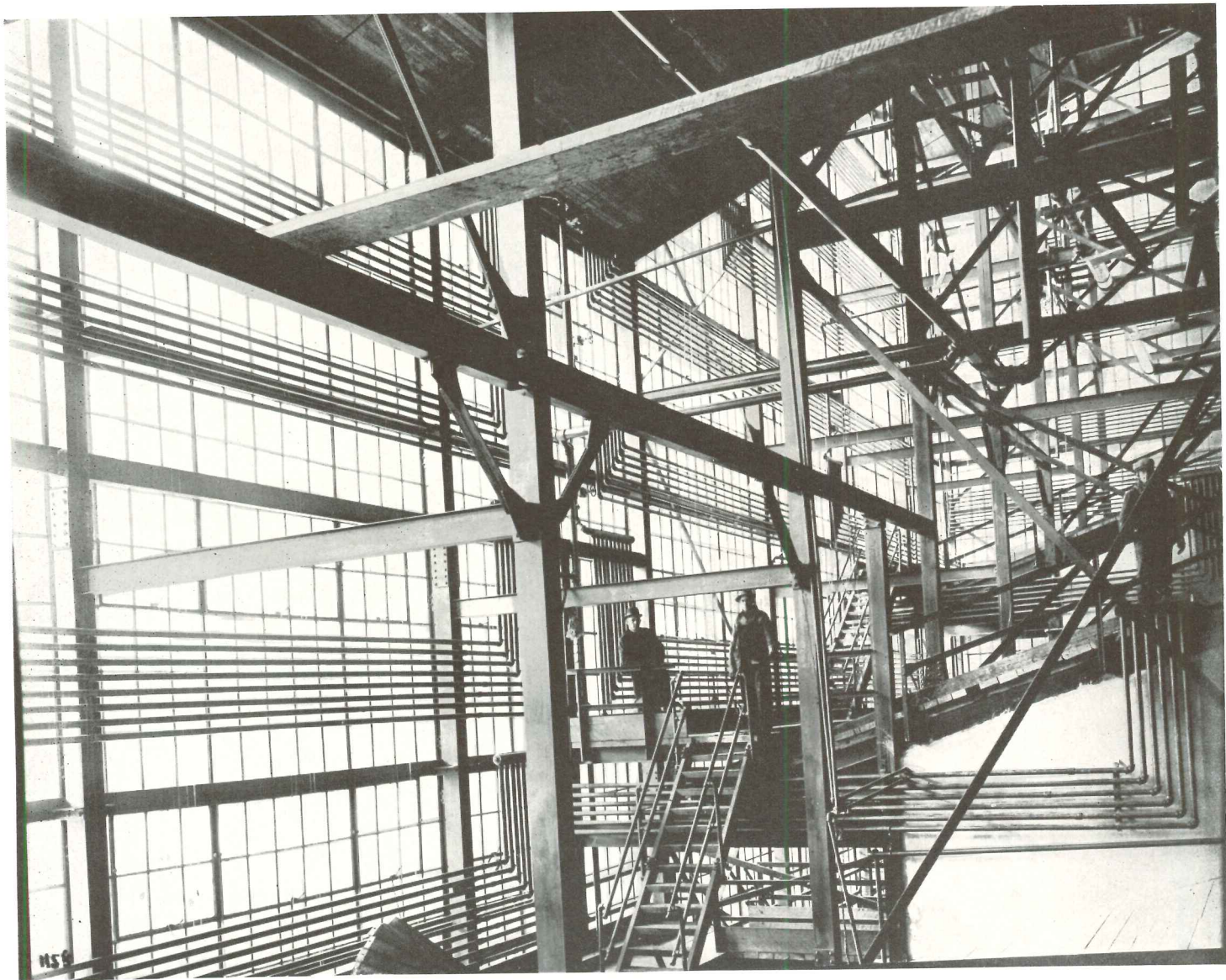

LOOMIS COAL BREAKER  
NANTICOKE, PENNSYLVANIA



## SITE

efore land is purchased for an industrial development, the architect could be consulted and his opinion could have weight in the final choice of a site, since most of the determining factors are within his competence.

The problem generally comes up as selection of a town or city or a section of a site in a given town or city. The site of the plant should offer definite advantages for the layout of the buildings and the manufacturing process. The choice of the land will primarily depend upon:

**ACCESS TO RAW MATERIALS:** The factory should be located close to the source of raw materials when they are heavier than the finished product. In a brick factory, for instance, the weights of the materials are: clay 40, finished brick 30, and coal 3. The factory must be located near the clay beds.

**ACCESS TO LABOR MARKETS:** The availability of labor and availability of residential areas with rapid conveyance to and from them is a matter of equal importance. The type of labor desired will determine whether the plant should be located near the big centers where a variety of skilled workers is available, or in the vicinity of smaller population agglomerations or, finally, whether residences near the workers should be especially provided.

**ACCESS TO CUSTOMERS' MARKET:** Location near the possible markets of the finished product is often preferred on purely selling or financial reasons, but especially when the finished product is heavier than the raw materials used. Facility for quick distribution of the finished product is another important advantage, and this is probably the main cause for the tendency of decentralization in the United States of some of the major industries, which are establishing smaller units in different localities whereby the time of distribution is minimized.\*

**FACILITY OF TRANSPORTATION:** The way the raw materials enter and the way the finished product leaves the plant will determine the general layout. Transportation may be effected by way of road, rail, water, or air. It is better to provide more than one way of transportation for se-

\*Report of Albert S. Low, vice-president of The Austin Company and the National Organization of Industrial Engineers and Builders.

Photo by Fairchild Aerial Surveys, Inc.



S T A N D A R D O I L C O M P A N Y  
B A Y O N N E , N E W J E R S E Y

curity of distribution and lower rates because of competition. Lately with improved highways transportation by road has become the most important. The water way, sea or channel, offers inexpensive transportation, but very often this advantage is counteracted by complicated foundation conditions and expensive land. Railroad offers many advantages, one of which is that immediate unloading is not necessary with cars as it is with trucks.

**5. TOPOGRAPHY OF LAND:** When the character of the materials and the process permit gravity methods of handling, a sloping site can be used advantageously.

**6. CLIMATIC CONDITIONS:** The meteorological records of the region ought to be studied because climatic conditions may affect not only the manufacturing process but the workers and their capacity to produce. While it is true that by controlling the air and the humidity of the plant we are able to provide excellent conditions, this adds to the expense of the primary operating cost which has to be taken into consideration.

**7. WATER ABUNDANCE** in the vicinity of the site, facilities for disposal of the polluted water and necessity for special treatment—as in some cases where the character of the waste is objectionable to the sewers.

**8. SOURCE OF POWER.**

**9. DISPOSAL OF WASTE.**

**10. COST OF LAND:** Whether the location is situated in large centers with high prices but definite known advantages or on undeveloped land with low prices but limited facilities and doubtful future developments. The local taxes should also be considered in relation to the land cost.

**11. RELATION TO URBAN AGGLOMERATIONS:** Special and expensive measures are often necessary to conform with building codes and regulations to protect the neighboring communities.

**12. POSSIBILITY OF EXTENSION:** Availability of neighboring land for the future growth of the plant.

Among 332 new factories established in 1933 in England the choice of site was:

27.10% For convenience of premises.

19.57% For proximity to other factories of the same industry.

14.15% Because of branch factories.

10.55% Accessibility of raw materials.

10.55% Proximity of markets.

6.93% Accessibility of labor.

6.93% Miscellaneous causes, decentralization, etc.

4.22% Because of cheap land, low rates.



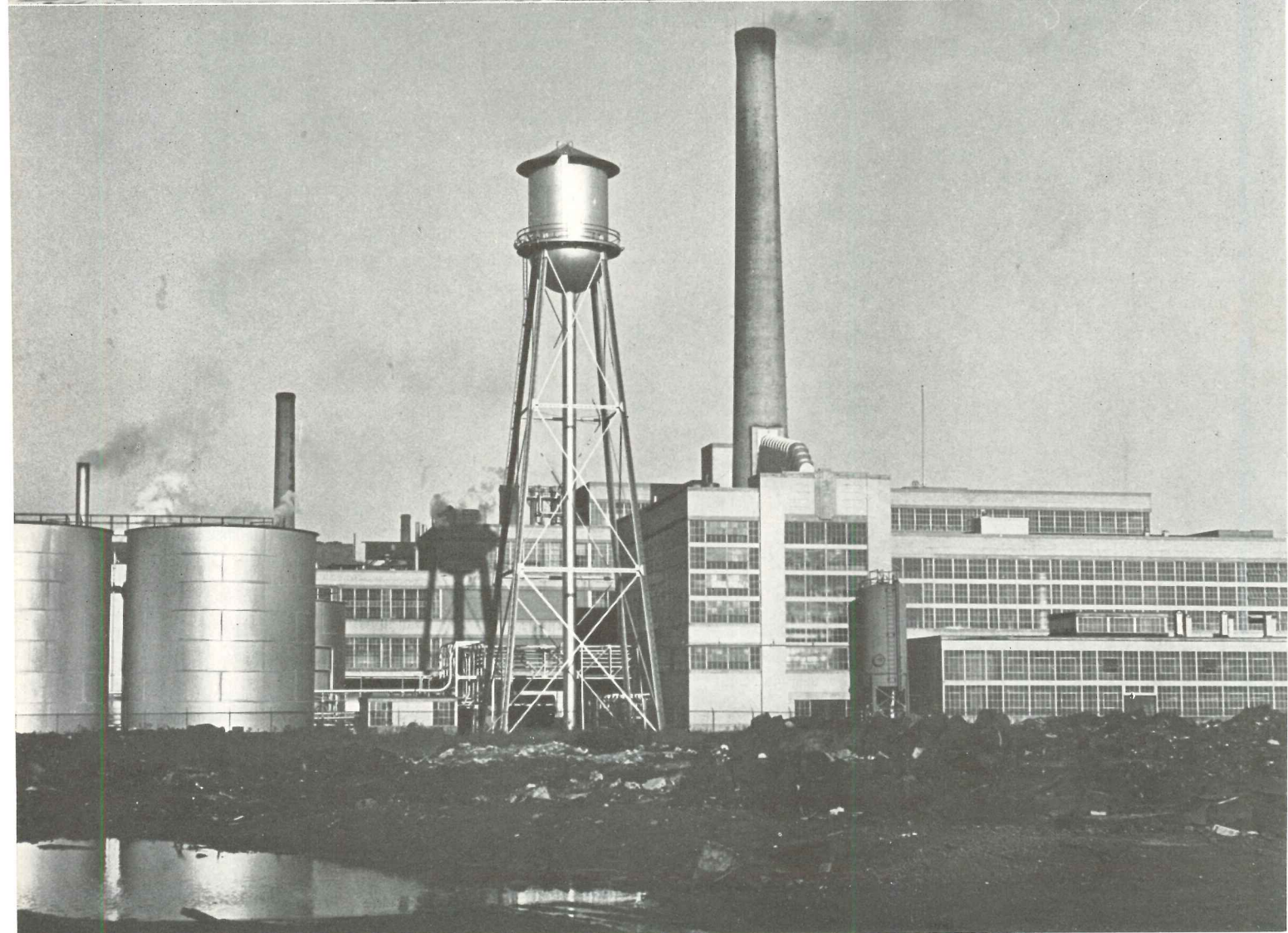
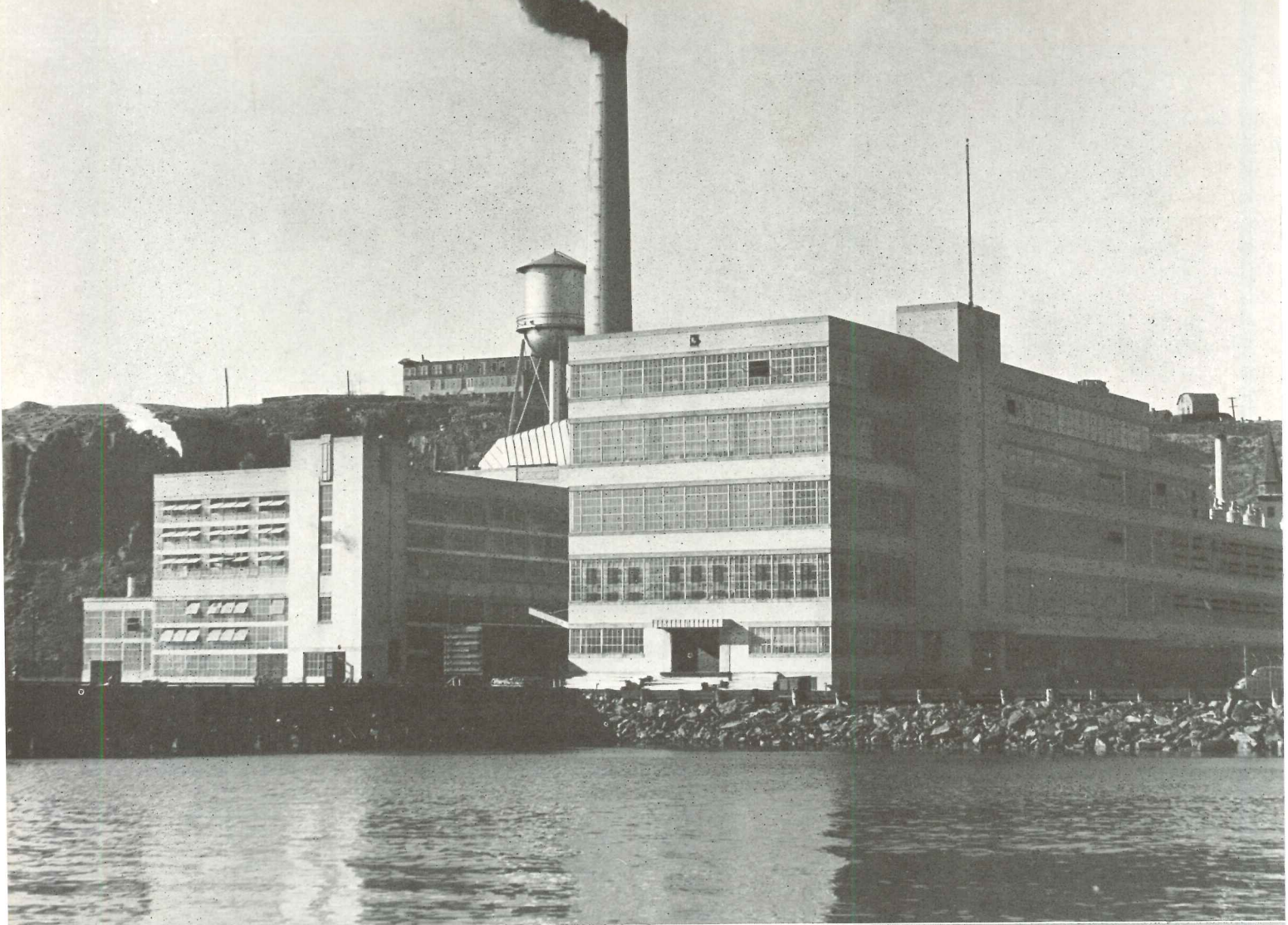



## LAYOUT

The layout of a manufacturing plant will define the areas for storage, parking and open spaces necessary to secure good lighting circulation between the different units and it will determine also the grouping of the process buildings, the location of the power unit and such annexes as gates, employment service, cloakrooms, lavatories, canteens, recreation rooms, first-aid, research and executive departments, and their mutual relations. The size of all the above services and departments depends on the importance of the plant. In small factories, for instance, they can all be accommodated in the same building.

The architect should have knowledge of the requirements of the process which will be used, both major and minor, the movement of the materials and the type of control. In his study, he has to be assisted by competent advisers. In the case of the Van Nelle Tobacco Factory in Rotterdam, there was a committee composed of the architects, one executive and the factory superintendent, which made all the decisions concerning the planning and supervised the erection of the buildings.

The final aim of the layout is to obtain the finished product at the least possible cost. The best time to insure economical operation of the factory as well as a minimum building cost is undoubtedly during the period of planning. Although the architect is not the one to determine the optimum profitable size of a particular factory, he has to provide minimum and maximum areas for possible extensions and so that any material change that may be required in the future in connection with an increase of output will not cause an interruption of the operation of the plant.

The factors which primarily should be taken into consideration are

- a. The size of the article.
- b. The quantity to be manufactured.
- c. The machinery to be installed.
- d. The method of control.

According to the size of the product we have three classifications: pieces small enough to be carried in trays, usually manufactured in large quantities; pieces big enough to be handled



CHEVROLET MOTOR CAR PLANT  
BALTIMORE, MARYLAND. Albert Kahn, Inc., Architects

separately; pieces which cannot be handled by man power.

For the location of every machine-tool, the required area is the proper area of the machine with the necessary clearance for the moving parts and the space for their operators. In the case of very small machinery the space between operators should be indicated rather than between machines themselves.

The control serves to check the quality of the product according to specified standards. There are two methods in use, the process control where the article is inspected several times at the various stages of its production, and the product control which consists of the inspection of the finished product. The latter method saves space in the process room and allows the machinery to be placed closer together.

The process chart or flow diagram is made by noting one after the other the number of operations, transportations, temporary storages and controls up to the permanent storage.

Besides the case of single process, we may have parallel similar processes which can take place at the same building with a common storage; the parallel dissimilar processes where goods of more than one type are produced and stored separately; and dissimilar processes directed towards a single assembly room for the making of a complex article.

Although every factory has its own problems, there are a few basic principles in making the layout. Materials and parts should follow the shortest route, from the storage of raw materials to the point of dispatch. Manufacturing speed is mainly obtained by elimination of unnecessary motions. The processing areas should be occupied by only the processing units and their operators. The traffic routes should be entirely independent of the route of the work—no crossings between two routes of work. Heavy and light machine shops must be separated, also assembly and finishing shops. In heavy works the floor space, being the most expensive, should not be utilized for actual processing.

**GATES:** The gate control building separates the entrance of the vehicles and the workers. The workers' entrance should be covered and should allow several persons to enter at a time. At the gate building are located the time clocks, a waiting room for visitors, and a smaller room where visitors can be interviewed without entering the factory. Facing the vehicle entrance is the office of the checking clerk, the records and the mechanism of the weighbridge. The vehicles entering and leaving the factory should be forced to pass at the weighbridge. Its dimensions are usually 6'x18'. At the gatehouse is often located the meter room.

**PARKING SPACES:** There are

opposite Page: LEVER BROTHERS PLANT,  
ROSELAND, NEW JERSEY. Designed by  
G. B. Post and Webster.

Photographs by Zimmerman



three distinct parking places to be provided: garages and parking spaces for the trucks, for the factory workers' cars, and for the visitors' cars. Workers' and visitors' parking spaces should be located for easy supervision by the gatekeepers.

**POWER UNIT:** If a power unit has to be provided, its location will depend upon the route of fuel supply, the ease of removing the ashes, the proximity of water and the position of those buildings requiring the greatest consumption of power and steam; it should be grouped with the heating plant of the factory.

**WAREHOUSES:** Provision must be made for the storage of raw materials, for work depot and for storage of the finished product. The work depot for temporary storage of parts or unfinished goods can be a special inclosure or a provided area in the process shop. The warehouse where the articles are stored and packed is often a multi-story building. Its depth is not lim-

*Photograph courtesy PWA*

ited because there is no necessity for good lighting, and low floor height is advantageous. The location of the packing space depends upon whether the articles are packed before or after storage. Loading docks for trucks and railroad cars are an important part of warehouses. In case they are not located within the building, they should be protected against the weather by a canopy, preferably glazed, extending at least 3' beyond the road, and must leave a vertical clearance of at least 18' to admit sufficient light above the tops of vehicles. There are two types of docks in use, the continuous platform where the trucks back or stop alongside, and the type forming a bay with platforms at both sides of the truck. Their height usually is 3'-6" above the road. Platforms for railroad cars are higher, from 3'-9" to 4', and at a distance of 2'-6" from the rail.

**EMPLOYMENT SERVICE:** The employment service can be a separate

building located near the medical service (if such a service is provided), order to facilitate medical inspection or it may occupy a part of the ground floor space of the office building. Usually it contains a waiting room with toilet facilities, one or two interview rooms, a space for efficiency tests. It will also contain the office of the staff manager, the time records and the pay office. Training schools for employees are often located there.

**MEDICAL SERVICE:** The importance of the medical department depends upon the number of employees and the number and nature of the anticipated injuries. The department may contain only a consultation room, a first-aid room or a general medical service including dental treatment. In this case the injured employees should be separated from those waiting for medical inspection. Besides the first-aid room, there must be provision for two or more treatment

*(Continued on page 40BT)*

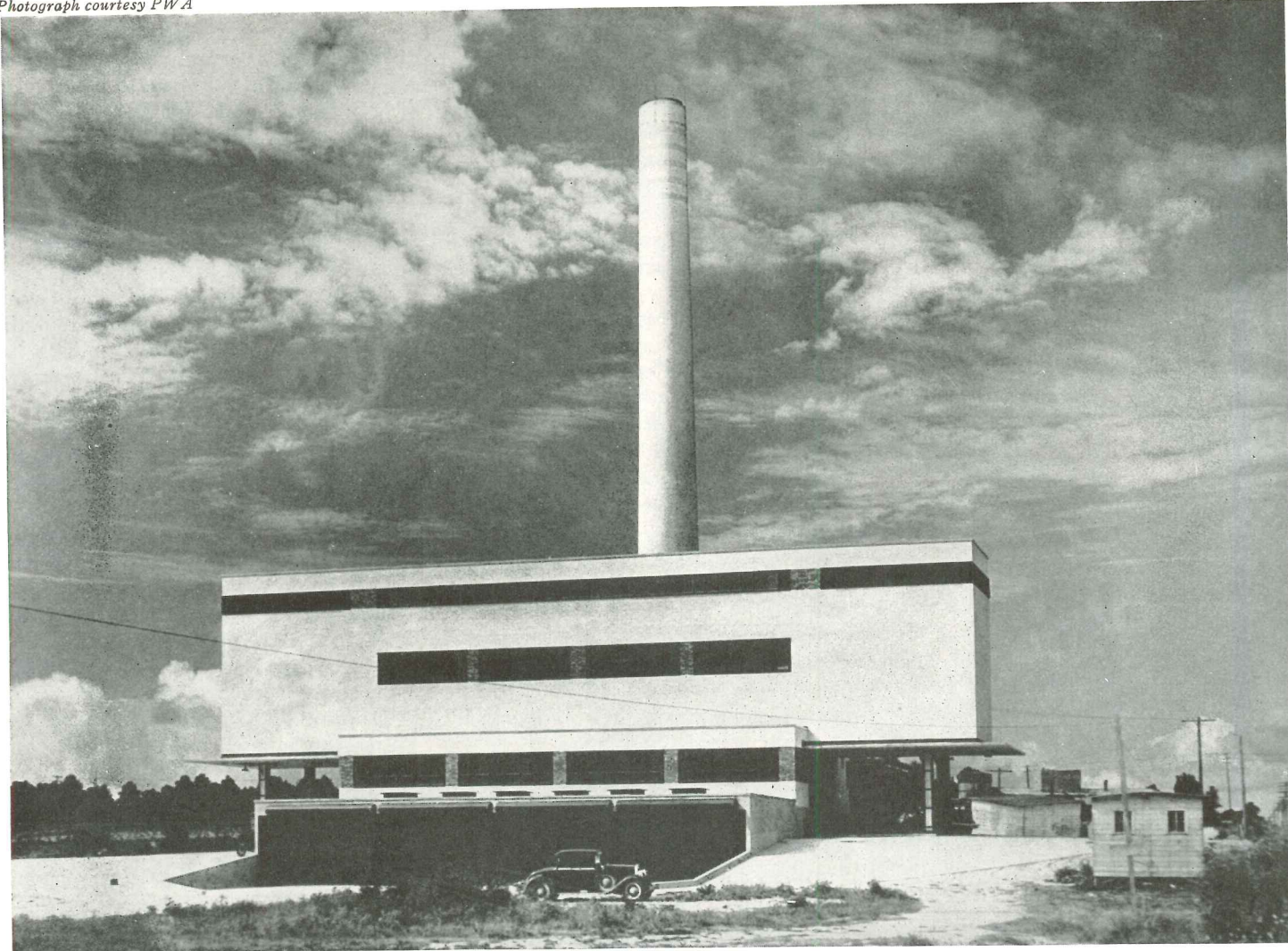

INCINERATOR AT SHREVEPORT, LOUISIANA  
built with PWA funds. Jones, Roessle, Olschner and Wiener, Architects



## CONSTRUCTION

Fenster

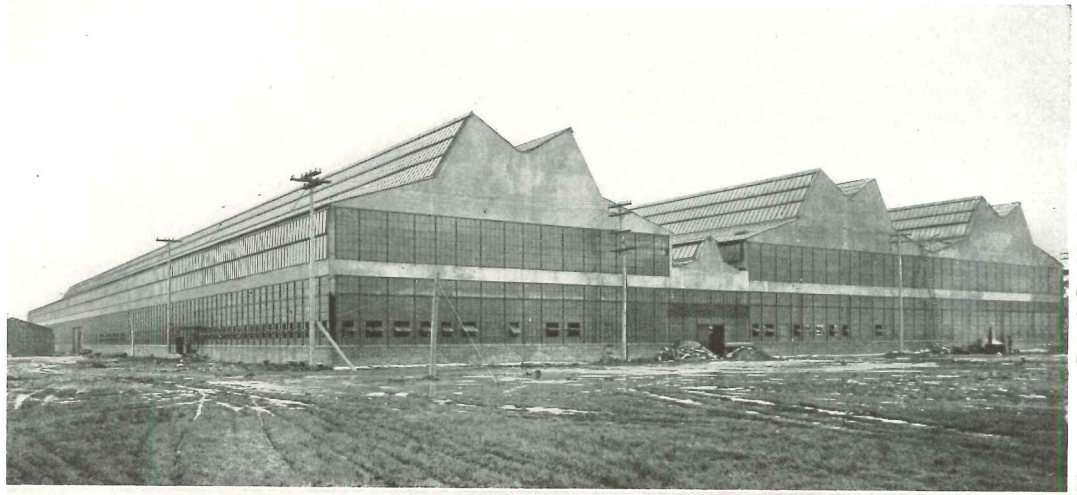

1

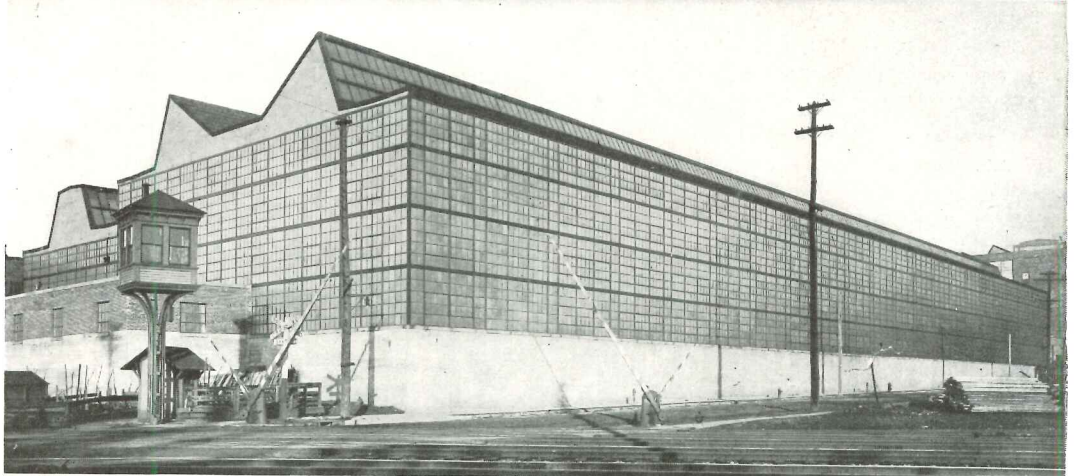

2

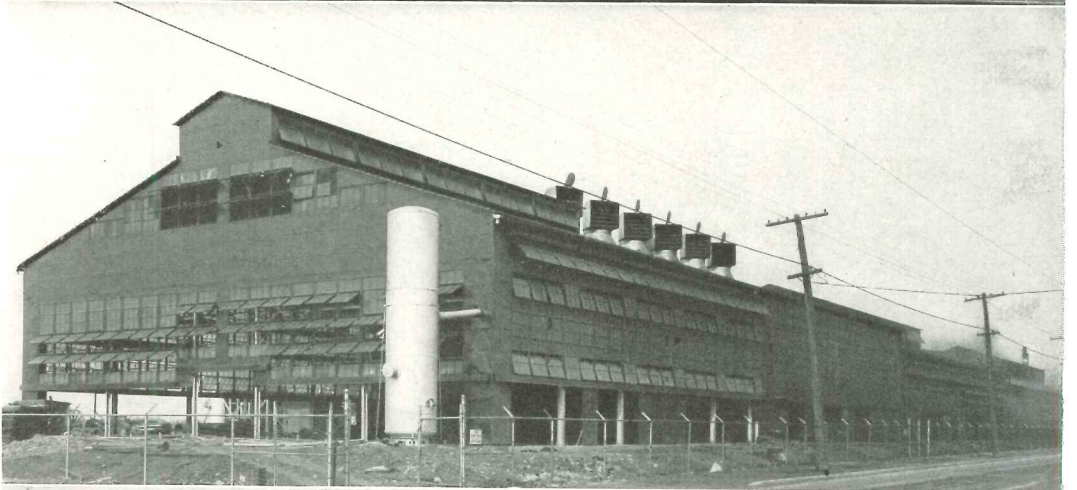

3

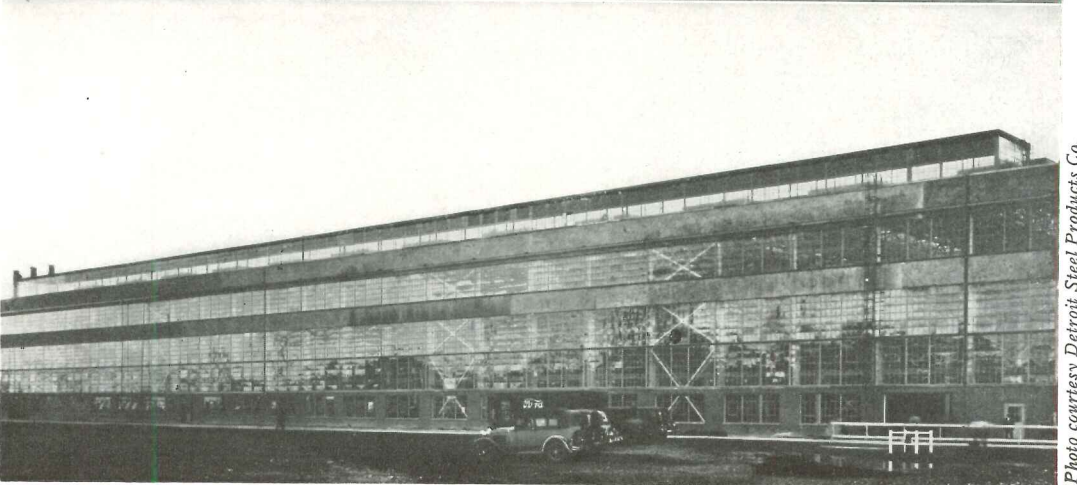

4

Photo courtesy Detroit Steel Products Co.

Photo courtesy Detroit Steel Products Co.

The design of the building to be used and the type of construction will derive from the final layout and will be determined by the nature of the product and the route of the manufacturing process. The weight of the materials to be handled, the circulation between the manufacturing machines, their size, the transmission of power: all these requirements call for definite widths and heights to be taken into consideration in establishing the size of bays and spans and in adopting an appropriate section.

Attention must be given to the usable floor space in connection with the operating cost. Generally there are four types of buildings: the one-story, the multi-story, the combined single and multi-story, and the special buildings such as power-houses, breweries, etc.

The one-story building has been in most general use. Materials enter from one end and emerge from the other. This type is adaptable for heavy goods which require a crane service, and it has definite advantages:

- Larger spans are possible.
- Better natural lighting and ventilation.
- Cheaper foundations for heavy machinery and less transmission of vibration.
- Easier and more economical control.
- Only lateral spread of e.
- Possible expansion in every direction.

**K Y L I G H T S  
A N D M O N I T O R S**  
DETROIT SEAMLESS STEEL  
PIPE COMPANY, DETROIT,  
MICHIGAN. Albert Kahn, Inc.,  
Architects. 2 MULLINS BODY  
CORPORATION, SALEM, OHIO.  
GREAT LAKES FORGE COM-  
PANY, CHICAGO, ILLINOIS.  
FORD MOTOR COMPANY,  
WARREN, MICHIGAN. De-  
signed by Giffels and Vallet.



The width should not exceed five times the height of the building if one side windows are provided. A greater height is better from a sanitary point of view but it increases the initial cost of the building and the operating cost of heating, etc.

There are four distinct types of sections of the one-story buildings:

1. With flat or sloping roof with or without glazed parts. It is economic for small spans.

2. The saw-tooth type in north-south orientation and with angle varying with the different latitudes. Because the southern sky is brighter than the northern in some cases it is advisable to orientate the openings to the south and use a glare-reducing coating on the glass during the summer. The span can reach the 100 feet or more (superspan of the Ballinger type). This section offers uniform lighting but presents certain difficulties in cleaning the windows and requires delicate roof construction to avoid water leakage.

The Austin Company of Cleveland has recently developed a continuous rigid saw-tooth frame formed by the welding of rolled beam sections, which permits economical construction of spans up to 50 feet and entirely free of cross members and trusses.

3. The monitor type with vertical or sloped windows. The monitor can be in one direction, in two, or in meander. In this section there is clear space for overhead hoisting tracks and the windows are easily cleaned as compared with joining flat roofs. Also the entire area of the windows can be opened. The distance between the monitors should not exceed or be equal to their height. The best daylighting can be secured when the width of the monitor is equal to half the width of the building, and if vertical windows are used. Also, for the same reasons, the height of the monitor should not exceed half the width.

4. The east-west skylight offers more light than the saw-tooth type and the windows are easily cleaned, but the light should be diffused by panels.

1, 2 FORD MOTOR COMPANY, RICHMOND, MICHIGAN. 3 EDISON LAMP WORKS OF THE GENERAL ELECTRIC COMPANY, HARRISON, NEW JERSEY

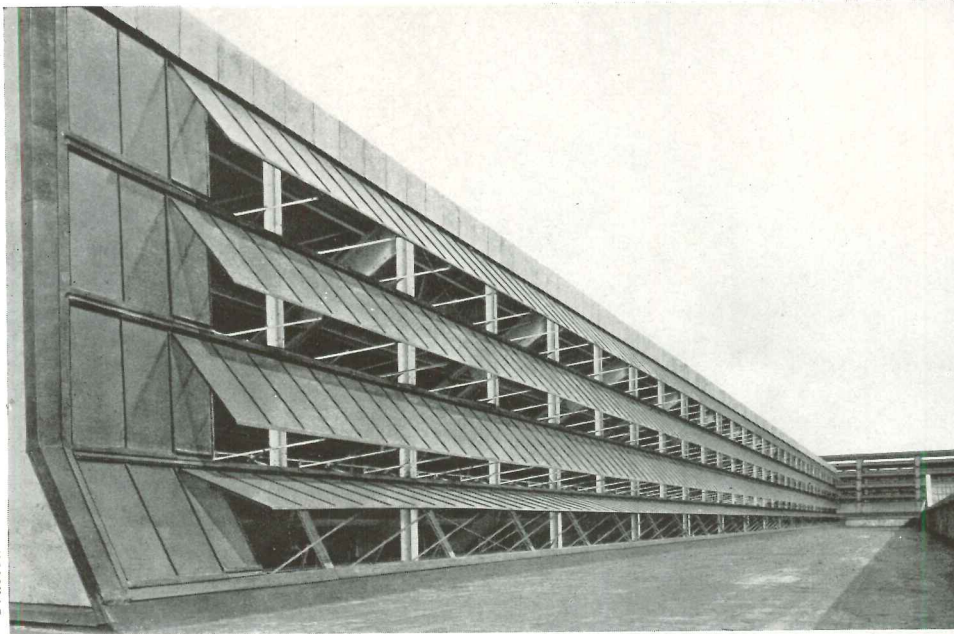

1 Trusscon

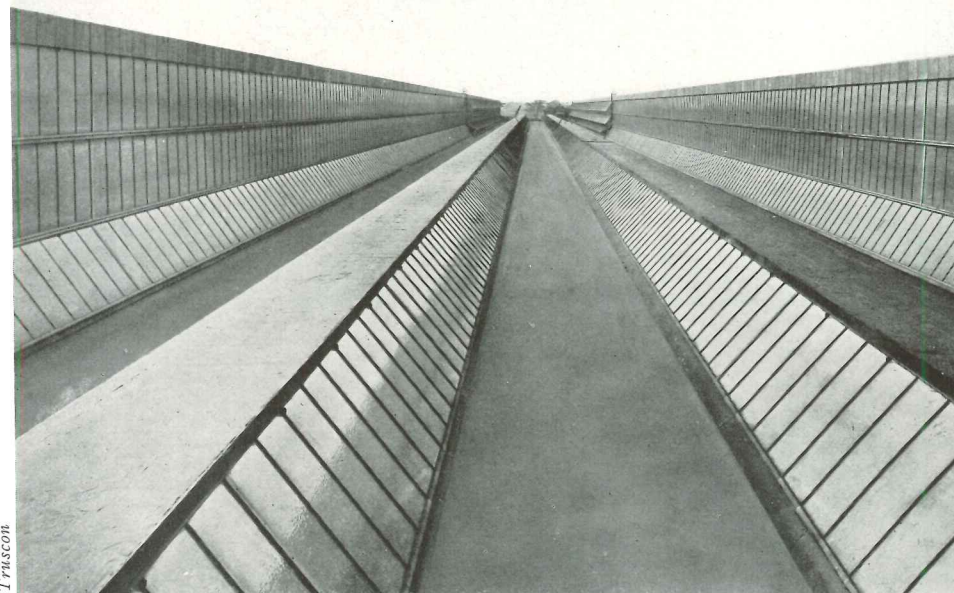

2 Trusscon

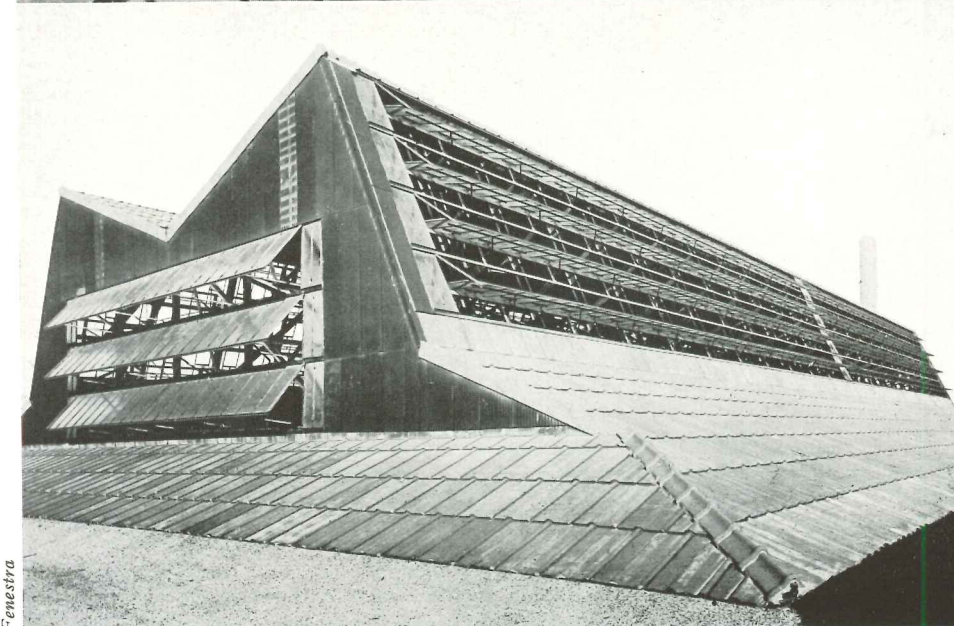

3 Fenestra

C O N T I N U O U S W I N D O W S



tic or ribbed glass.

*the Multi-story Building.* It is used for light manufacturing and storage. It has some advantages such as easier pervision and distribution of power, and less expense in heating and venting; but most of all economy of cost when the latter is an important factor; this type is usually advisable when gravity methods can be used for handling the materials.

On the other hand we have smaller spaces than in the single-story buildings, less of space because of the stair wells, shafts and the greater number of vertical supports, and natural lighting is limited to side windows. The area of the windows being related to the floor area, we have to restrict the width of the building if ceiling heights of 12 to 15 feet are to be used. Also there is a loss of time in handling the materials and the expense of operating and maintaining the elevators.

If the ceiling must be free for pipes and ducts the mushroom type of construction should be used instead of the beam and slab construction. The exterior walls, if cantilevered, will allow a continuous row of windows which could extend to the ceiling in order to offer a wider lighted area. The windows usually are located 3'-6" above the floor.

The type of the raw materials and the product will determine the capacity of the freight elevators, the size of the shaft and openings. A margin of safety should be considered in case of possible change of the materials to be carried. The shafts should be lined with fireproof walls, also the corners of the openings must be of fireproof material. At least a second stairway or fire escape is obligatory. The multi-story building combined with a single story serves usually as a rehouse or offices.

When high fire resistance is necessary, the use of reinforced concrete masonry is recommended.

2 Glass blocks in panels 51 feet long and 10 feet high have been used for the CORRUGATED CONTAINER FACTORY OF OWENS-ILLINOIS GLASS COMPANY, GAS CITY, INDIANA. Designed by The Austin Company. WAREHOUSE FOR THE ENTERPRISE CAN COMPANY AT McKEES ROCKS, PENNSYLVANIA. Designed by Francisco and Jacobus.



1

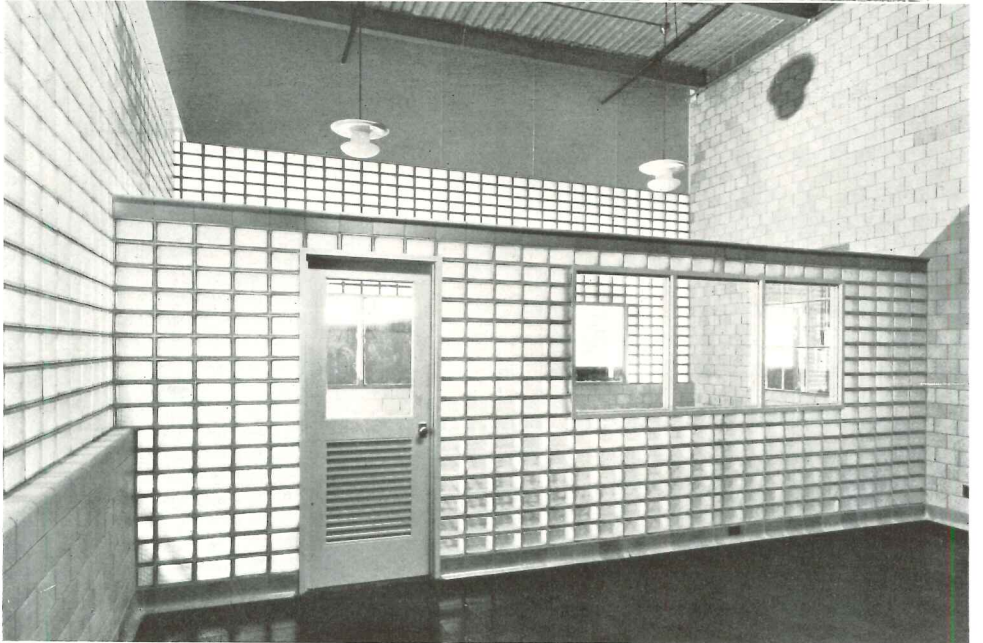

2

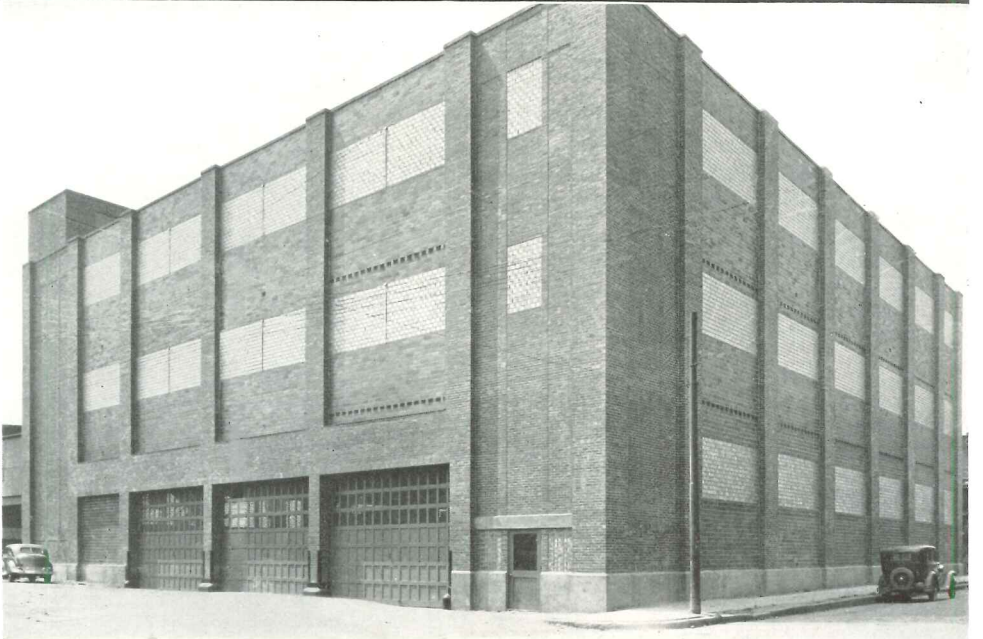

3



Welded steel frames, lately in use, facilitate the attainment of large areas without vertical supports.

Prefabricated wall units of corrugated asbestos cement or similar materials reduce the time and cost of erection and have certain advantages, being fireproof, rotproof, rustproof, nonporous. They do not corrode and they do not require paint or any other protection.

Usually the concrete floors are covered with wood blocks with the exception of heavy works. The floors have to resist the wear of steel-tired trucks and the action of corrosives; they must be watertight, dense, and wear-resisting. Therefore special attention must be given in mixing and curing the concrete.

Windows for daylighting and natural ventilation are important factors in the factory building. There is nothing more essential for the speed and high quality of the work than sufficient and evenly distributed light. And we can never obtain more than minimum illumination. The window area must be at least 30% of the floor area. It will then secure a 10 foot-candle minimum when the sun is hidden and the windows are not cleaned for six months. The windows of factory buildings are always dirty; since they are not cleaned more than twice a year, provision must be made to counteract the loss of light transmission. Vertical windows lose 50% of their efficiency; with 30° slope they lose 75%, and with 60° the loss is 83%. If only vertical windows are used in one side of the building, an area with a depth equal to twice the window height will admit light of 10 foot-candles or more. When windows are placed in both sides, the depth of the lighted area is equal to three times their height. The types of windows in use are the pivoted or projected with individual sash, or continuous top-hung windows, supplied with clear sheet, vertically ribbed, horizontally ribbed or hammered wire glass.

Lately, glass brick was introduced into the factory building, mainly to take the place of steel sash and to fill masonry holes. But it is probable that in the future a more functional and independent use will be made of this material. Glass brick has certain advantages. It is not subject to corrosive

*(Continued on page 40BT)*

**1** Sawtooth frame formed by the welding of rolled beam sections developed by The Austin Company. **2** Skylight and glass walls of the CHRYSLER CORPORATION PLANT AT DETROIT, MICHIGAN. Albert Kahn, Inc., Architects. **3** Top-hung windows of the COMMONWEALTH STEEL COMPANY AT GRANITE CITY, ILLINOIS.

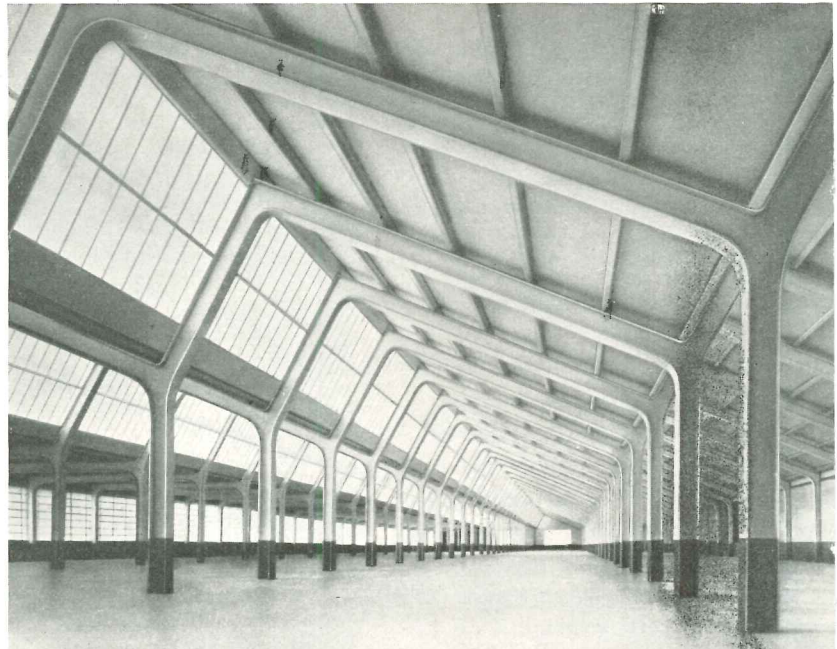

1



2

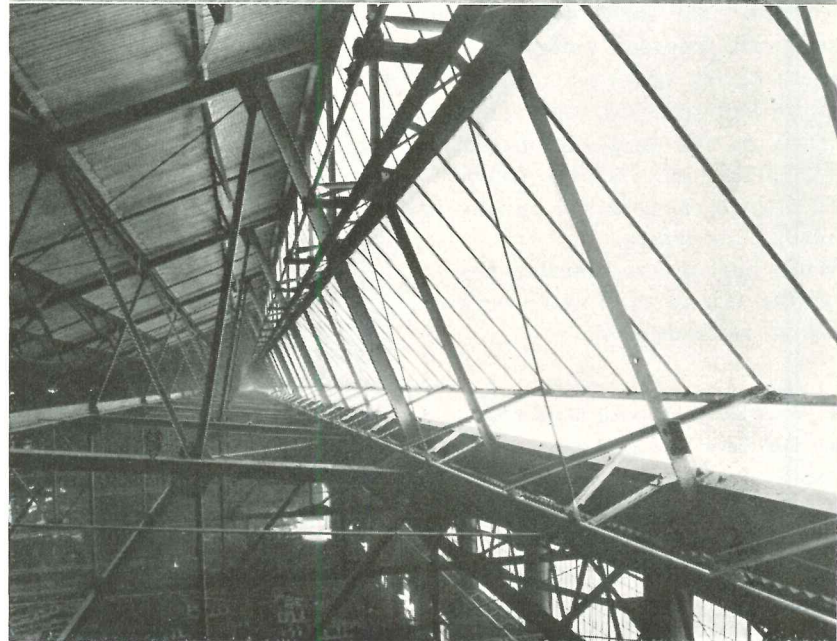

3



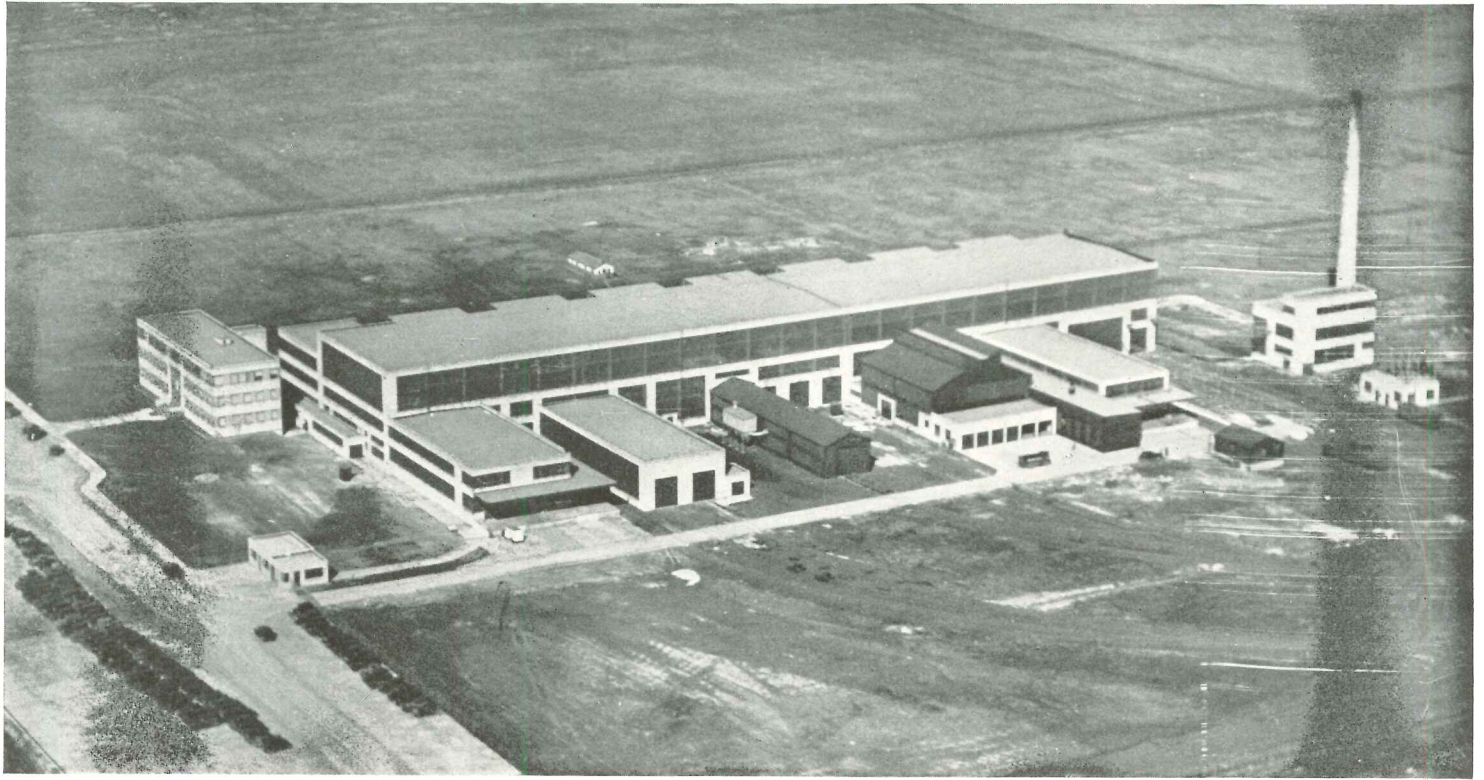

# ELECTRO-MOTIVE CORPORATION WORKS

AT LA GRANGE, ILLINOIS

DESIGNED BY THE AUSTIN COMPANY

The plant was built by The Austin Co., to facilitate progressive production methods in the manufacture of locomotives weighing up to 200 tons. Its welded electric traveling crane is the largest ever operated on a welded structure.

The structural steel throughout nine buildings included in the project represents an unusual application of electric welding for heavy structural work.

The largest building—550 feet x 170 feet—houses the erection shop and machine shops. It is surrounded by 57,000 square feet of horizontal sash, which incloses the structure even at

the corners. The main erection aisle has a clear span of 104 feet, with 49-foot clearance under the roof trusses. This aisle extends for more than 500 feet and consists of 24 locomotive construction bays, most of which are served by track laid transversely in the aisle. The individual bays have been designed for specific steps in locomotive construction and are closely related in function to adjacent facilities for heat treating, shot blasting, painting, etc., which are housed in individual structures that open directly onto the main erection aisle on the east. Track serving these bays connects with two and

a half miles of the company's service and test track which is served by a 200-ton track scale and approaches the plant from the east.

Alongside the erection shop and opening into it on the west is the machine shop. This has a clear span of 64 feet and extends the full length of the main aisle. While transverse monitors provide for permanent lighting and ventilation in this part of the plant, the largest section of horizontal sash ever erected closes in its 550-foot west wall with one broad sweep of glass which will be removed when contemplated expansion is carried forward.



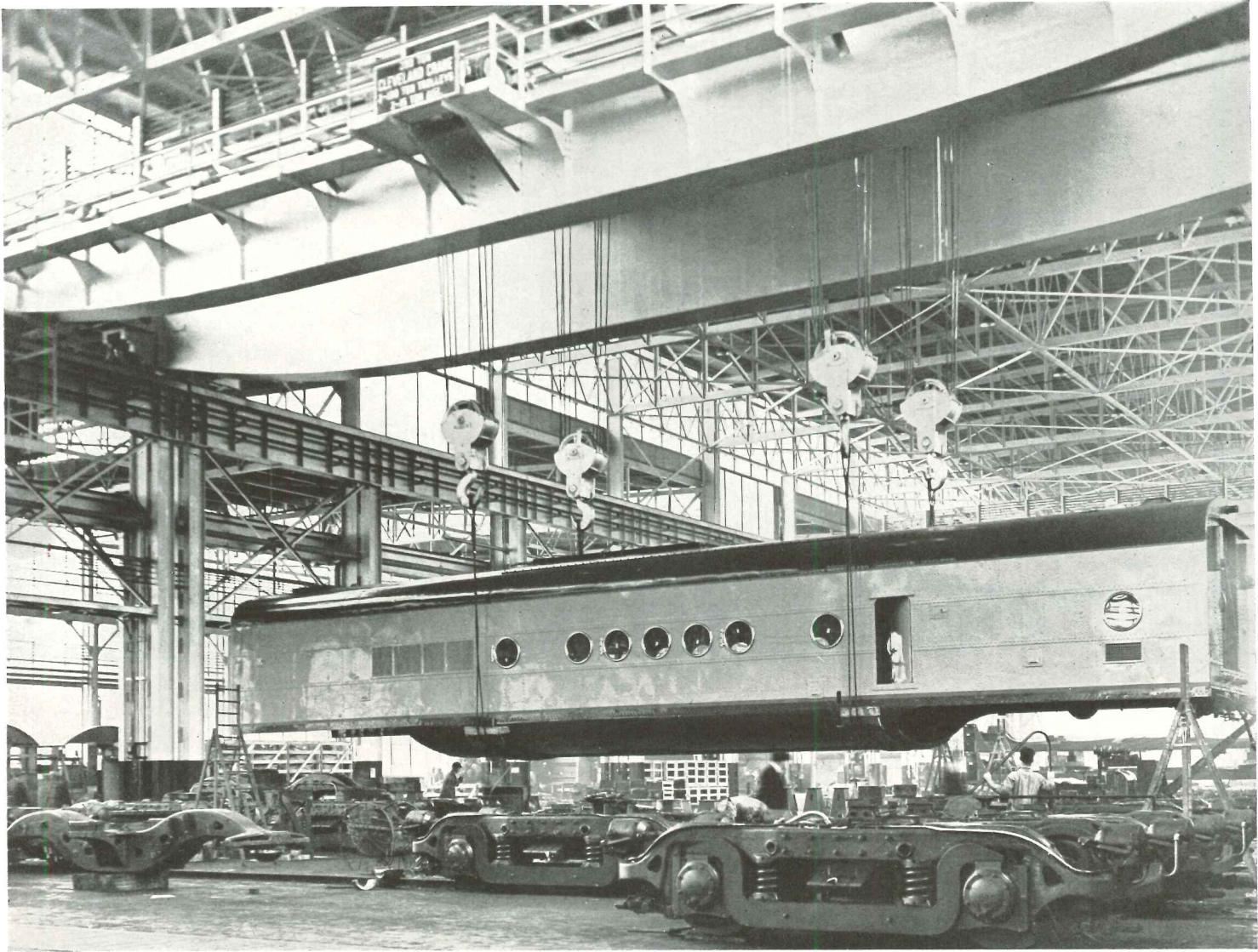

The all-welded traveling crane operating over a clear span of 104 feet.

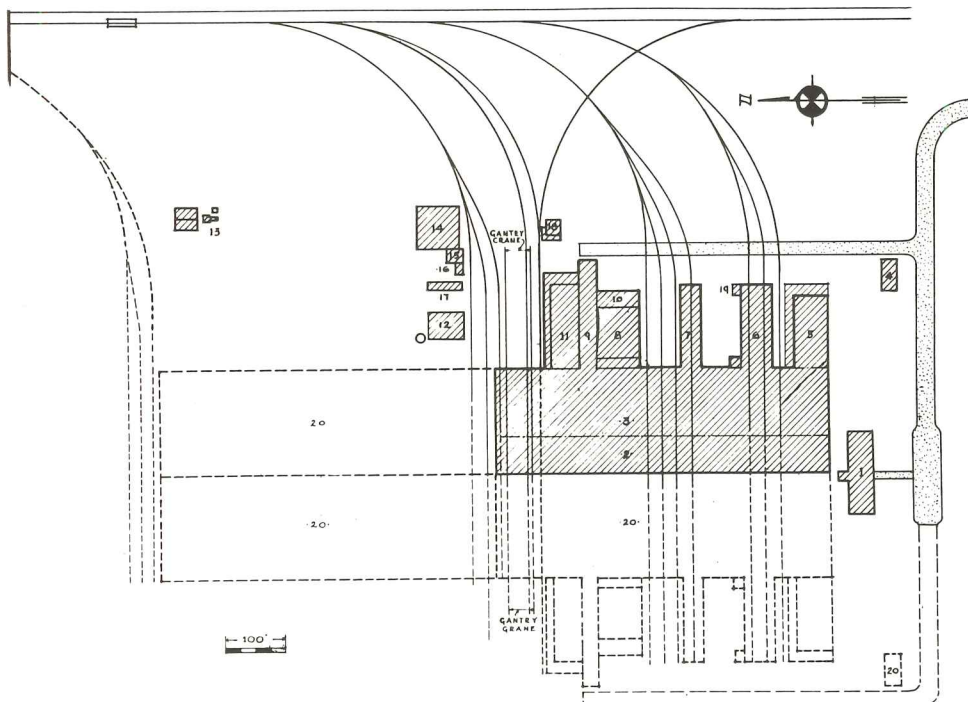

PLOT PLAN

- 1 Office Building
- 2 Machine Shop
- 3 Erection Shop
- 4 Employment Office
- 5 Parts Department
- 6 Paint Shop
- 7 Sand Blast
- 8 Blacksmith Shop
- 9 Annealing Oven
- 10 Garage
- 11 Warehouse
- 12 Boiler House
- 13 Sewage Disposal
- 14 Reservoir
- 15 Pump House
- 16 Switch House
- 17 Sub-Station
- 18 Gas House
- 19 Paint Storage
- 20 Future Extension



The machining of all the major locomotive parts occurs in this aisle, while smaller precision parts, instrument panels, etc., are finished on a balcony at the south end of the main aisle situated above the shop superintendent's and shop office quarters.

Dies, machine parts and other shop equipment supplies are concentrated in a department which is located at the head of the machine shop aisle.

In the main erecting aisle a 200-ton all-welded electric traveling crane, itself weighing 205 tons, has been installed on track supported on the structural columns which separate the main aisle from the machine shop on the west and from the heat treating, shot blasting, paint shop and other structures on the east.

The two auxiliary electric traveling cranes of 30 and 40 tons capacity which supplement handling facilities in the main aisle and the balcony precision machine shop, as well as the 200-ton crane, are equipped with hydraulic bridge brakes and Clark face-plate type controllers. Power is provided by Winton Diesel engines on test at the plant. This aisle is also served by a 15-ton gantry crane which passes transversely through the plant at the north end on rails in a double bay 48 feet wide. This track extends 200 feet along an unloading area outside the plant to facilitate bringing heavy materials into the shop. Two 20-ton traveling cranes answer handling problems in the machine shop.

The size of the structure and the necessity for a diversified current distribution to all parts of the plant for purposes of illumination, welding and a wide range of machine operations resulted in the installation of individual transformers on alternate columns along the entire length of the main aisle on the west. In this way the necessity for installing three or four substations through the building, each with its own oil-cooled transformers, was avoided and small transformers were provided at 48-foot intervals with three-phase 440-volt feeders carrying current to the lighting transformers, which convert this power into a single-phase 200-volt, with 110-volt secondary.

Measured illumination has been provided throughout the plant by direct lighting. Aluminum reflectors with special noncorrosive finish assure undiminished brightness without excessive maintenance. These reflectors carry 1,000-watt lamps on the roof

trusses 49 feet above the working floor in the main aisle. They are arranged so that the traveling cranes cannot interfere with the light from more than one outlet at one time.

Coordination of all the production operations was sought in the layout with the result that the unloading dock, blacksmith shop, annealing ovens, shot blast building, paint shop and warehouse for storage of locomotive parts adjoin the main erection aisle as integral branches on the production line. The annealing oven, 22 x 70 feet, has been constructed to receive the entire frame of the largest locomotive at one heat up to 2,000 degrees. A flat car, surfaced with fire brick, serves as the base of this oven and transports frames or other parts directly from the main aisle over a track leading from the erection shop to the oven itself.

At the north end of the main building is a testing room where two Winton Diesel engines will be on test at all times. Power generated by these engines is adequate to meet the direct-current demands of the plant. Because of the necessity for changing the engines on test at frequent intervals, this section has been fitted with a removable roof and can be served by the two cranes in the machine shop aisle. Adjacent to this engine test room is a locomotive testing pit and the power generated here can likewise be converted to constructive use in the plant.

With this source of industrial power and its own complete water supply system, modern sewage disposal plant, fire protection apparatus, and efficient heating plant, the works could operate entirely independently of all public service facilities. A 1,600-foot well, drilled through the limestone bed, furnishes water at a rate of 310 gallons per minute to the 200,000-gallon reservoir whose capacity would be sufficient to supply the needs of a community with 2,500 inhabitants.

The sewage disposal plant was developed by Austin engineers in cooperation with sanitary health authorities of the state of Illinois. Sewage from the plant runs by gravity into an octagonal basin inside the base of the power-house stack (which thus serves a dual purpose) and is pumped from this basin into the sewage disposal plant nearby. Steps leading into the base of the stack make it possible to clean the basin at all times.

The layout has been designed to accommodate shops four times the present size without augmenting the ser-

vice facilities. It will permit extension of the plant to double its initial length without necessitating the installation of additional cranes, and duplication of such extended facilities on foundations partly in place alongside the west wall of the present building. In this way, the 200-ton crane, the 40-ton crane and the 30-ton crane in the main erection aisle and the two 20-ton cranes in the machine shop will be available for service over an area double that of the present structure.

After the present plant has been doubled in length and it becomes necessary further to expand the facilities alongside, the existing wall of horizontal sash inclosing the machine shop on the west will be removed. Column footings and columns on this west wall have been constructed in anticipation of this development, so that nothing further need be erected to support the roof on this side of the extended machine shop, and only stub columns are necessary to carry the crane girders.

A three-story and basement office building serves as business office for the Electro-Motive Corp. and as headquarters for its engineering staff, which has been provided with a drafting room occupying the entire upper floor. A complete Frigidaire air conditioning system has been installed in the office building, with automatic controls to cool the air in summer and circulate and humidify warm air in winter. A cafeteria, located in the basement, is available for use by office employees and executives, with service from a kitchen in this building which is the source of meals transported to workers in the plant by means of motorized facilities. A ramp connects the kitchen and the plant, while a covered 15-foot passageway makes it possible to go from the office building upper levels into the plant without going outside.

Location of the office building is such that it will be equally accessible to all sections of the plant after extension of the initial facilities to four times the present size, as this has been contemplated from the outset.

The 74-acre site near La Grange, fourteen miles southwest of Chicago, was the sixth tested by engineers before a selection was made. The extremely heavy loads, the necessity for adequate area and removal from quiet residential areas, plus the urgency of locating where adequate labor and residence accommodations were available, finally dictated selection of the farm site in March 1935.



# WIND TUNNEL AT CHALET-MEUDON

Structural Design and Construction: SOCIETE ANONYME DES ENTREPRISES LIMOUSIN

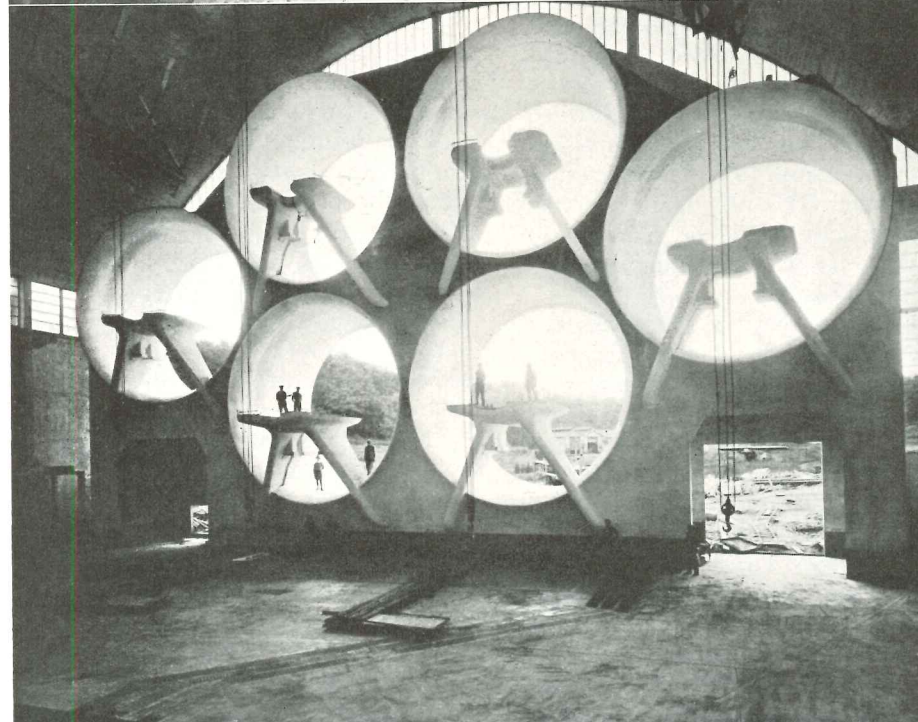
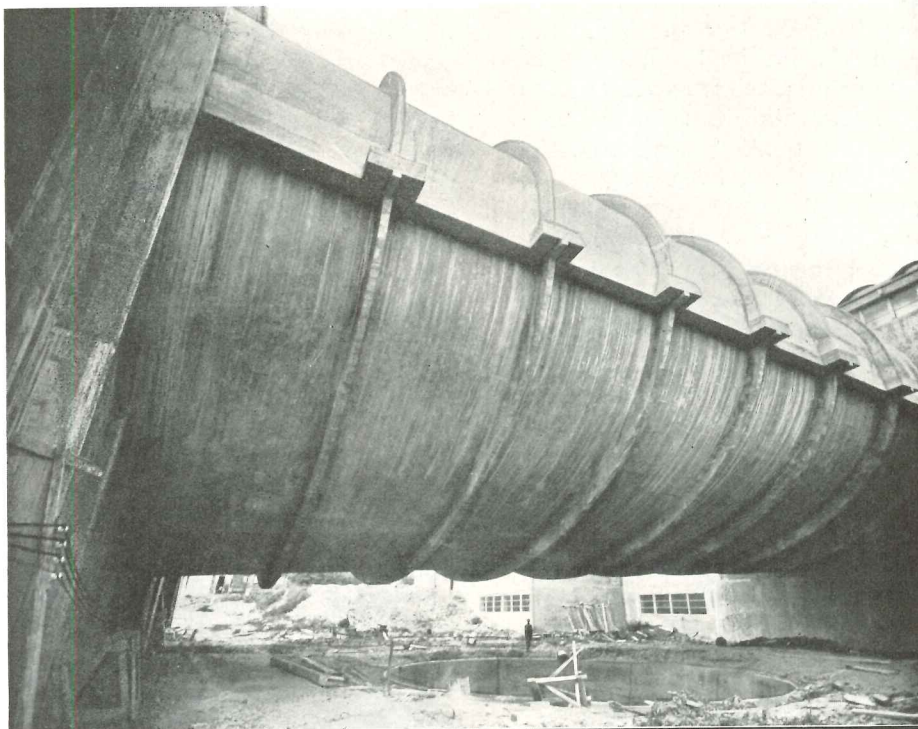

*Photographs—Portland Cement Association*

THE FRENCH AERONAUTICAL TECHNICAL SERVICE erected at the air base of Chalet-Meudon a large wind tunnel for practical testing of airplanes and appliances. There are five distinct parts of the structure:

1. A collector designed to draw in the exterior air, to filter it and to set it in the right direction before entering the testing chamber.

2 The housing of the six propellers. To avoid transmission of the vibration, the wall ends 5 feet below the roof.



3 The central diffuser opening from the testing chamber. The fan-like shutter slides down into a slot in the foundations.

4 Aerial view of the building.

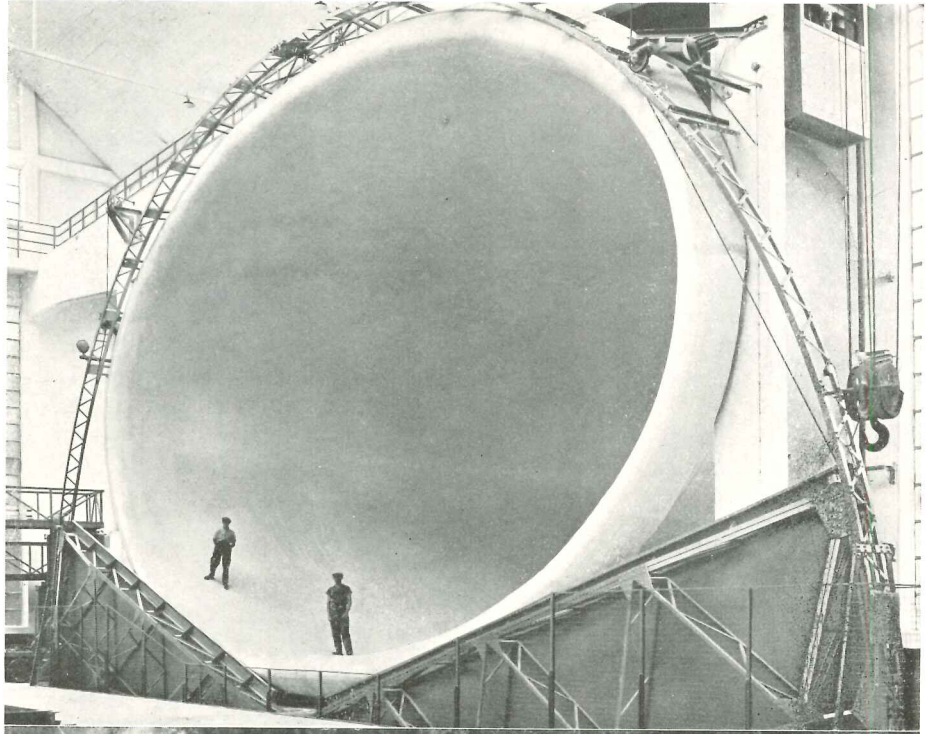

3

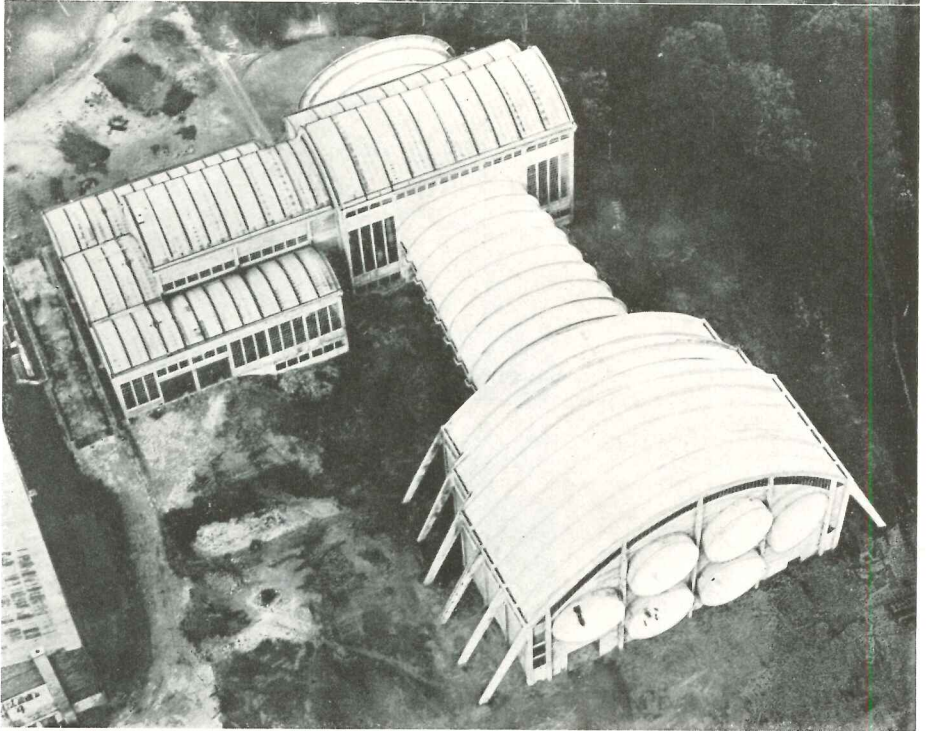

4

The collector has a height of 50 ft.; its section is ellipse with a horizontal axis of 81 feet at the entrance and 52'-6" at the testing chamber and a vertical axis varying from 55 to 26 ft. The shell is made of reinforced concrete 2¾ in. thick, stiffened by outside ribs.

Both collector and diffuser openings have metal shutters.

2. A testing chamber in which the airplane is placed for the tests.

This chamber is 65x69 feet and 45 feet high. An observation balcony is located there and a traveling crane places the airplanes in position.

3. A central diffuser, made to regulate the flow of air from the testing chamber. The diffuser is 124 feet 6 in. long with an unsupported part of 112 ft. The shell is of 2¾ in. reinforced concrete of elliptical section, with horizontal axis varying from 59 to 79 ft. and vertical axis from 33 to 49 ft.

4. Air exhaustion chamber, serving as a regulator between the central diffuser and the propellers. It is 95 feet long and its width varies from 118 to 140 ft. The height of the roof varies also from 74 to 85 ft.

5. Six propellers create the air current by exhaustion of the interior and force the air outside. A draft of air 312 feet long moving at speeds up to 113 m.p.h. is thus created.



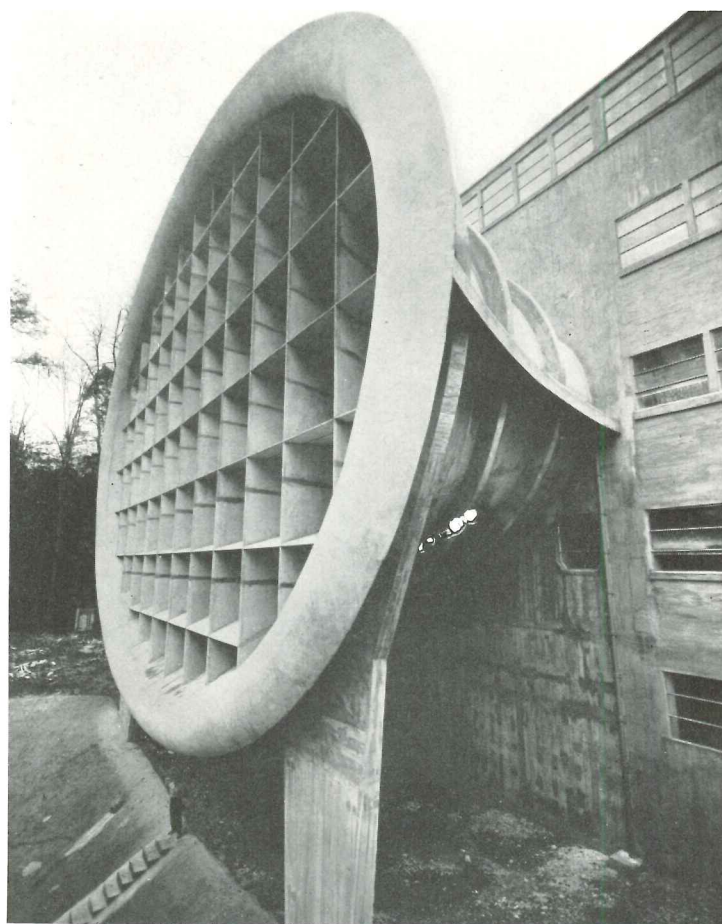
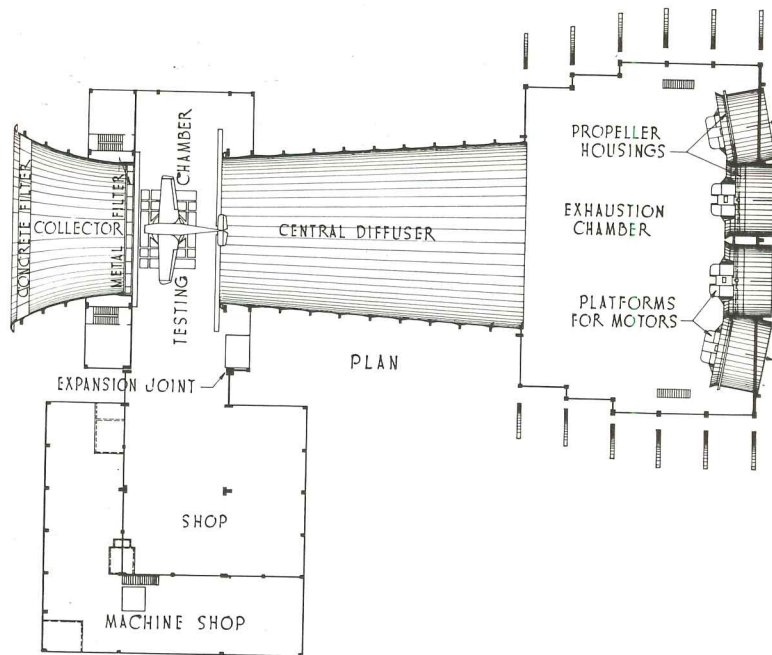

Collector and filters made entirely of reinforced concrete.





Photograph by A. Blyth

# A PACKING PLANT IN EDMONTON, ALBERTA

ERIC R. ARTHUR, Architect

ROBERT J. McLAREN, Associate Architect

The new plant of Canada Packers is located in Edmonton, Alberta, in the center of an important hog and cattle country. In addition to supplying local demand for packing house products, it is planned so as to take care of regular shipments by rail to Vancouver, the East and British markets.

Local traffic comes by truck from what is called the local shipping dock. Two lines of tracks take care of shipments of edible products for both coasts and cities between, such as Winnipeg and Toronto. A second spur runs to the so-called inedible dock. Here inedible products, fertilizer, hides and the like are shipped to points throughout Canada and the United States. A third spur brings cattle to the stock pens.

The plant is designed to handle the following livestock:

Cattle .....	600 per week
Hogs .....	3,000 per week
Sheep, calves, etc.....	300 per week

The building is divided into two parts:

- (a) The coolers.
- (b) The manufacturing, in which is

the killing section, and the "edible" and "inedible" tank houses.

Planning on each floor will strike as an apparently unrelated collection of rooms. Between an "edible" room and an "inedible" there is no connection except through a vestibule. The real relation is usually a vertical one because the whole operation is based on gravity. Horizontal carrying of the product is reduced to a minimum.

The killing floor is in 3 sections:

1. Cattle killing and dressing.
2. Hog killing and dressing.
3. Coolers.

Of the two killing operations the cattle takes the larger area. Cattle are killed and dressed and pass into what is called the hot cooler to be chilled. Their hides drop down a chute to the basement while tripe, liver, hearts, kidneys, etc., drop to the second floor in the offal preparation room.

The hog killing is done in a narrow section on two levels, separated from the main killing section because of machine noise and steam produced in the preparation of the hog. The hog is first hoisted to a mezzanine floor along which he passes on a rail where

he is stuck and bled. From the mezzanine the hog falls into a scalding tub from which he passes into a dehairing machine. At this point the hogs are given slightly different treatment, depending on whether they are for local consumption or for export to England. The English hogs known as "Wiltshires," pass through a furnace or "singer" where the skin of the animal is partially cooked and takes on a golden brown color.

The hog is now in the main killing section and processing is similar to beef. Offal passes to the same room below and the dressed hog finds himself at last in the hog cooler. Government veterinary inspectors examine each carcass as it passes over this floor.

The second floor is concerned mainly with pork cutting, the fresh being prepared and sent to the assembly cooler for shipment on the first floor while hams, etc., go to the curing vats in the basement. On the second floor are also the oil refinery, sausage making and cooking, lard, offal preparation, and the coolers and freezers which are kept at temperatures from 10 below zero to 34 degrees. The construction





1 The free-standing reinforced concrete sign.

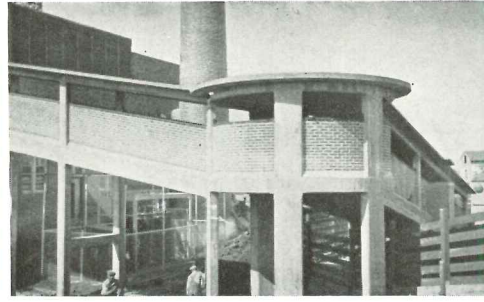

2 The ramp.

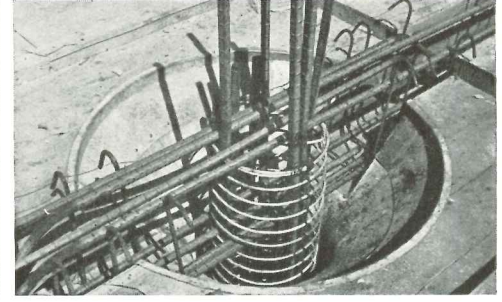

3 Reinforcement of a column.

of the coolers is unusual. The wall columns are split so that the whole cooler is enveloped in cork 6 inches thick without breaks or jogs due to piers or other obstructions.

The first floor, it will be noticed, is concerned with shipping, assembling and packing. The office, men's and women's dressing rooms, and hospital, are also on this floor. The plant women have a lunchroom on the mezzanine of their dressing room and the men's lunchroom is on the roof of the cooler.

The building is of reinforced concrete with a veneer of red pressed brick. Roofs are heavy built-up composition and all parapets are flashed with copper. All insulation is cork of which 13 carloads were supplied. The sign "Canada Packers" is in concrete

6 feet 6 inches high, standing on the parapet without any exposed reinforcing.

The unloading chutes for handling livestock received by motor truck are arranged to handle six trucks at a time. The courtyard in front of the unloading chutes is paved with concrete, well drained, and a paved area is provided for the washing and cleaning of the trucks after they unload.

Two livestock scales are provided in the livestock pens building. The floor of this building is paved with concrete with a rough surface to prevent slipping and injury to the animals.

The livestock ramp extends from the pens to the killing room on the third floor of the main building. The floor of the ramp consists of shallow steps,

3-inch risers and 16-inch treads. The surface of each step is perfectly level so that the feet of the animals are on level surfaces at all times. The concrete steps are scored from front to back in order to prevent side slipping of the animals. This type of ramp is very easy on livestock and can be cleaned readily.

Throughout the plant where trucking of materials is done the floors are paved with a special hard floor brick. In other rooms the floors are smooth concrete. All floors are well drained and easily cleaned.

All operating departments in the plant are heated by means of unit heaters suspended from the ceiling. Outside air is brought into the rooms through unit heaters, so that during cold weath-

4 Interior of the killing room.





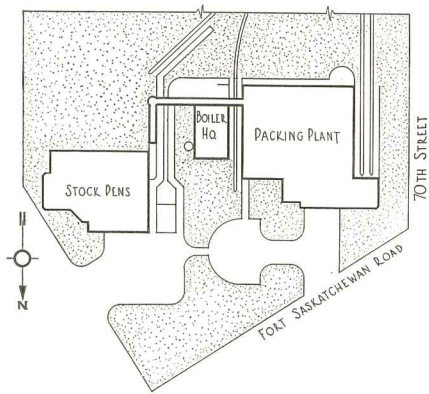

er the air may be tempered. Ventilation in the operating departments is insured by a system of ducts leading to a large central fan.

A chemical laboratory is provided to control the quality of all products and for the oil refinery and shortening plant.

The arrangement of the equipment for the oil refinery and shortening operations in this plant is very compact. The crude vegetable oils are received in tank cars and the oils are refined, bleached, deodorized, and converted into shortenings.

It is necessary to produce ice in a packing plant for use in the icing of cars and in some of the plant operations. The usual ice plant produces ice in large blocks which must be crushed before the ice can be used. This plant is equipped with a continuous ice-making machine which produces ice in small briquets. These are used directly in refrigerator cars without further crushing or other treatment. The ice plant produces thirty tons of ice per 24-hour day.

The ice is conveyed to the tops of the refrigerator cars by means of steel buckets suspended from an overhead track. The ice plant is located at the top of the building so that the ice is moved by gravity to the buckets which are pushed along the track over the cars.

All of the refrigerated rooms in the plant, except the low-temperature freezers, are cooled by means of air circulated through ducts by positive blowers. The air passes through special chilling bunkers provided with direct expansion ammonia coils and brine sprays. The temperature of the air is maintained by these bunkers and the humidity is also controlled. This system of refrigeration makes it possible to hold fresh beef without difficulty and the control of temperatures is very flexible.

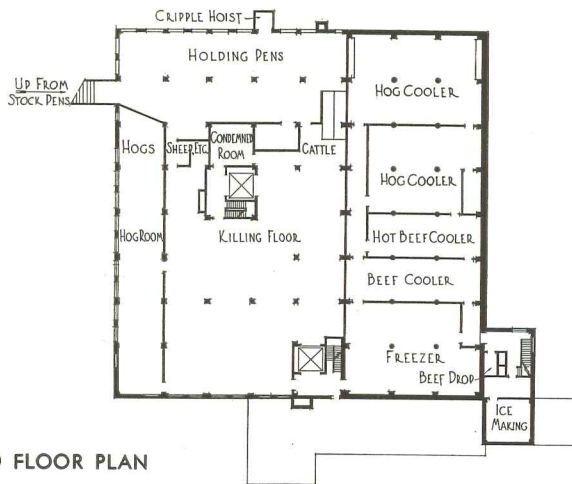

THIRD FLOOR PLAN

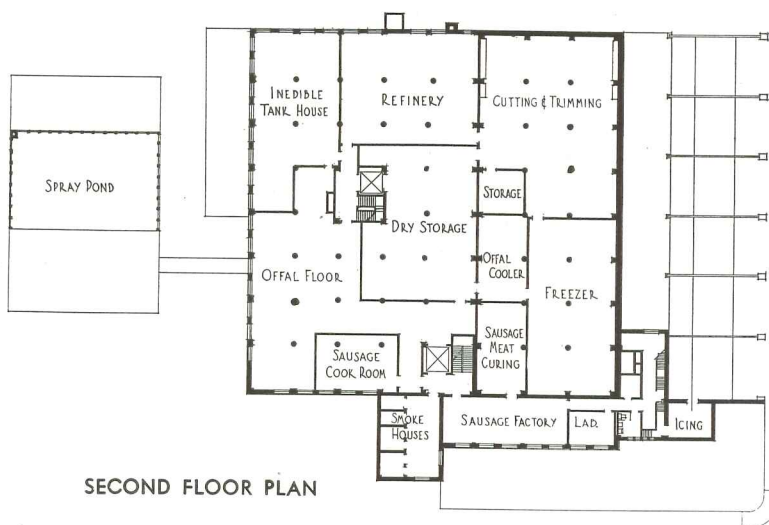

SECOND FLOOR PLAN

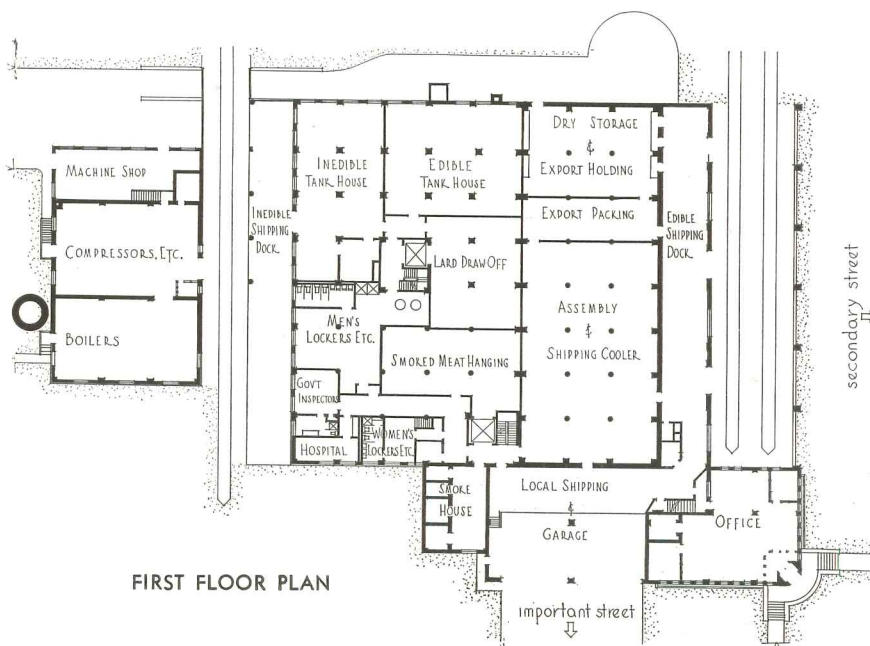

FIRST FLOOR PLAN



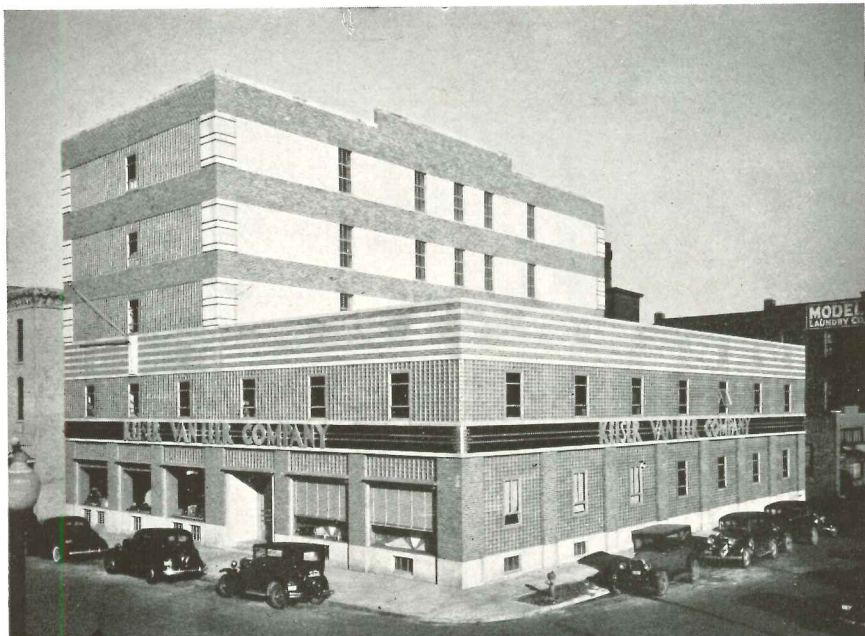

1 THE KEISER-VAN LEER COMPANY BUILDING AT BLOOMINGTON, ILLINOIS, where an ample use of glass blocks has been made. Shaeffer and Hooton, Architects.  
 2, 3, 4 PHOENIX LAUNDRY COMPANY BUILDING AT PHOENIX, ARIZONA. Janssen and Whittlesey, Architects; Gilmore and Ekman, Associates. Photograph 2 shows the Lamella roof construction.

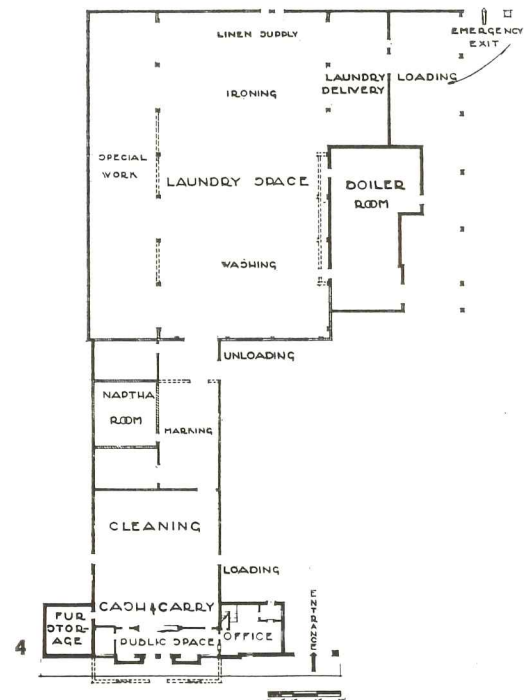
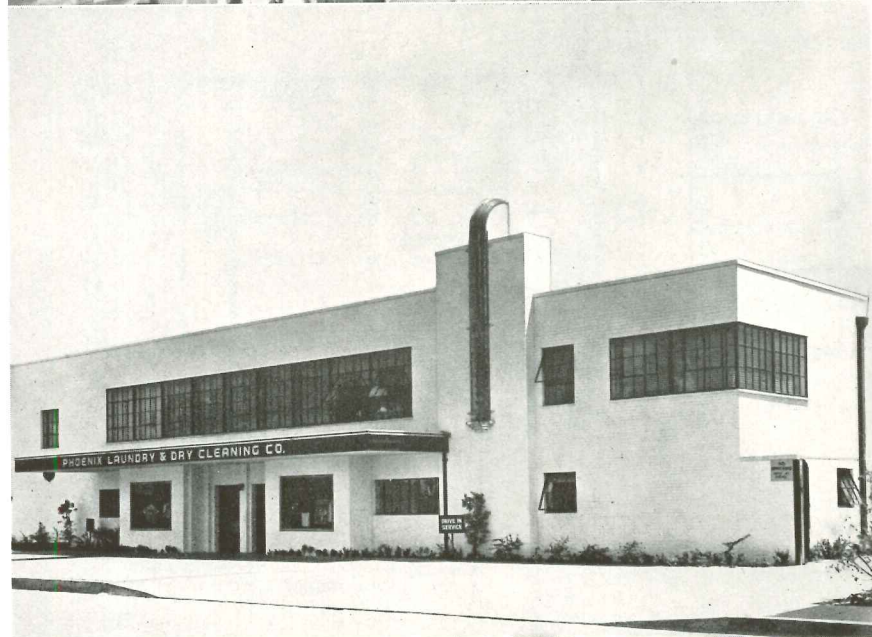



# SEED STORAGE BUILDING

HANS BRECHBUEHLER, ARCHITECT

information compiled by MAX ZIMMERMAN

One of the oldest and largest seed concerns in the world, shipping seeds over the entire globe, has its stores and offices in Berne and its wholesale warehouse at Köniz, about three miles away. The plant includes: (1) a warehouse for seeds; (2) a house containing the apartment of the warehouse manager, besides a garage, a germination laboratory, a heated seed storeroom and other miscellaneous facilities; (3) a hothouse directly connected with the laboratory; (4) a pleasure garden with garden house, and (5) an experimental garden covering one acre.

To meet this combined warehouse and garden requirement an ideal situation was found at Köniz, three miles from Berne. The buildings were grouped in relation to railroad spurs, approach, and sunlight orientation for the garden, hothouse and country house.

The warehouse contains a first and second floor used for storing bags of seeds, and a cellar for storing peat dust, dung, garden tools, and the like. The third floor is used for bulbs. From the covered railroad and truck-loading platforms the goods are routed directly into the elevator. Elevator, stairs, bag chute, office, and seed-cleaning machine are grouped together as free-standing light skeleton units, presenting minimum obstruction to a clear view through the plant.

The construction was determined by storage problems. Seeds require a space that is dry, airy and, if possible, cool, but they need no special insulation against summer heat. The ideal floor material is wood. It is dry and excels other dry materials because it not only transfers no dampness to the seeds but, on the contrary, absorbs their perspiration when they are fresh and gradually releases this humidity

1 The side of the building facing the experimental garden. 2 Prefabricated walls of asbestos cement and continuous bands of pivoting windows are the architectural elements of the elevations.

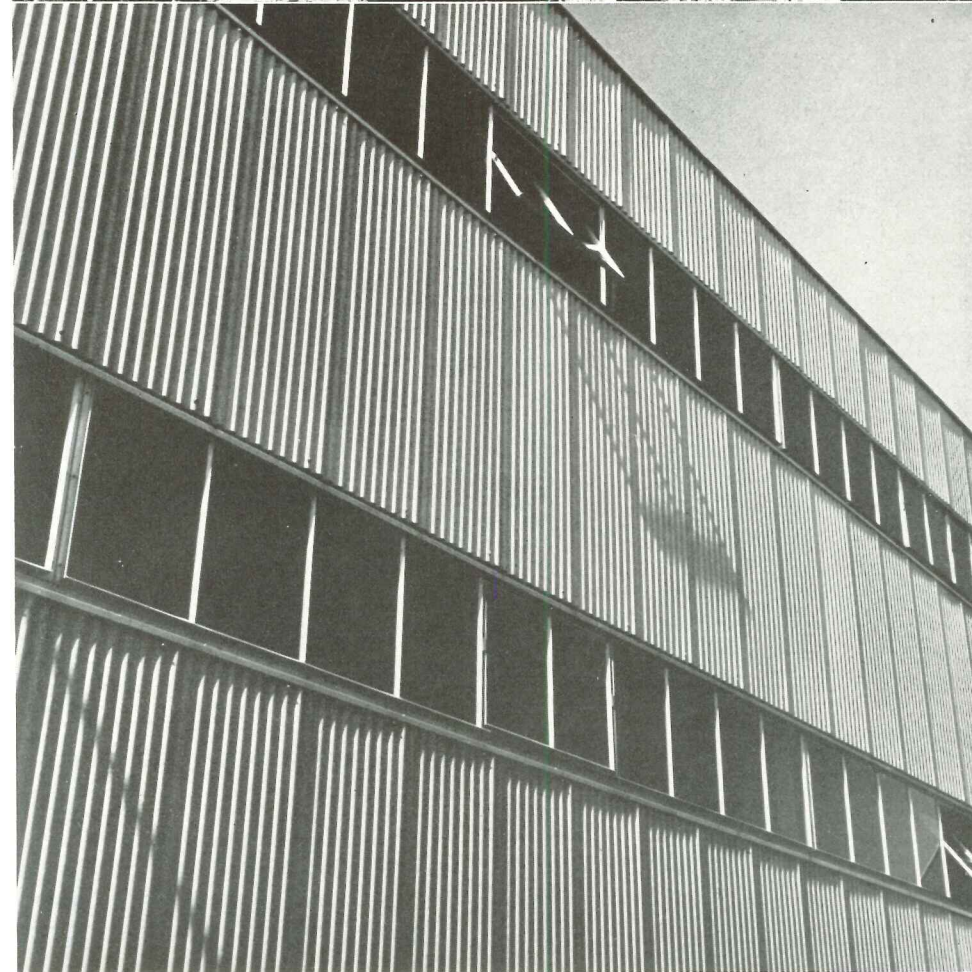
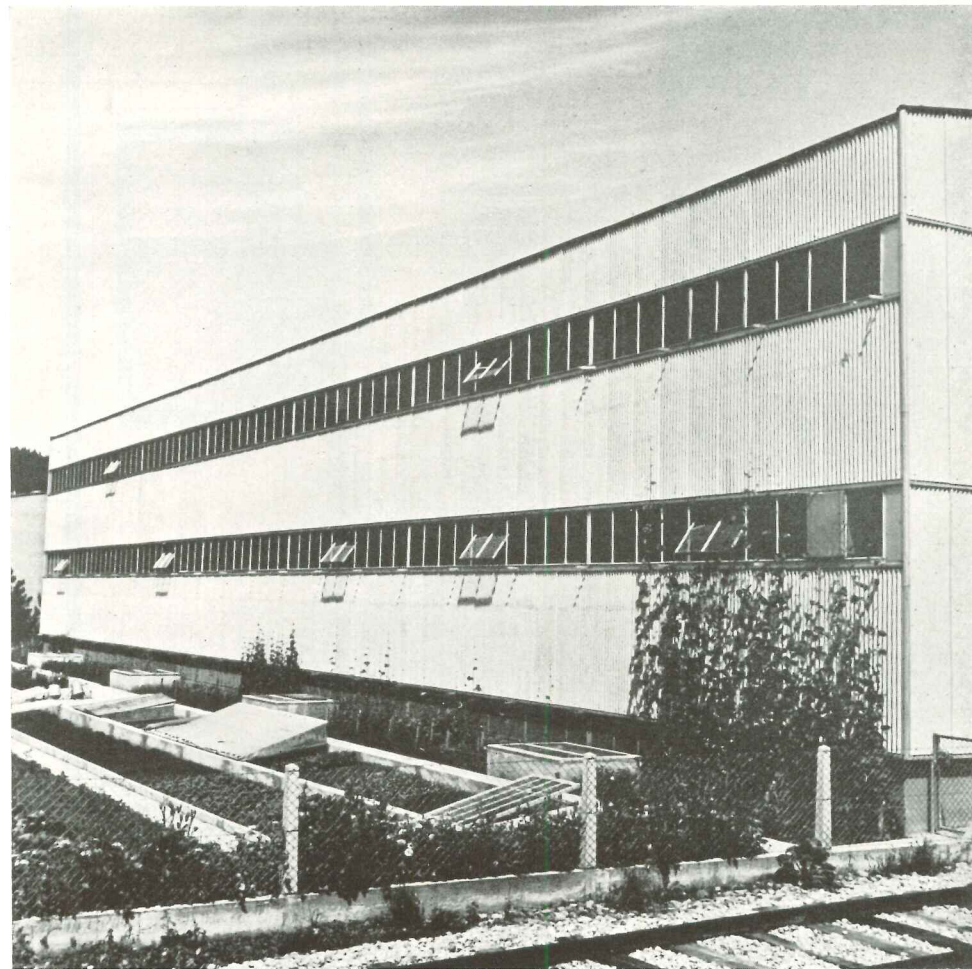

Photographs by Zimmerman



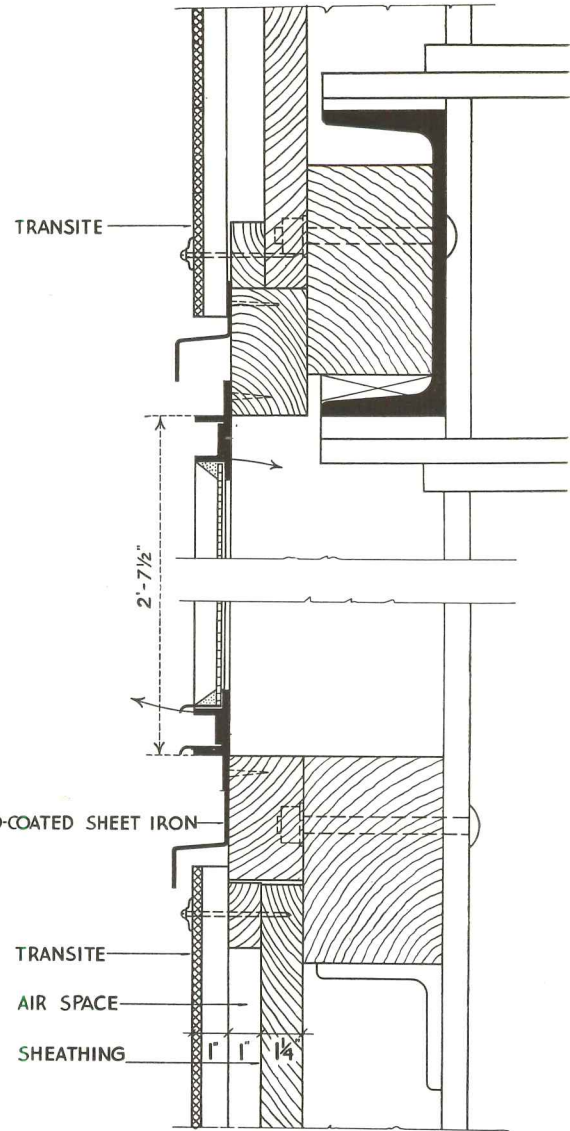
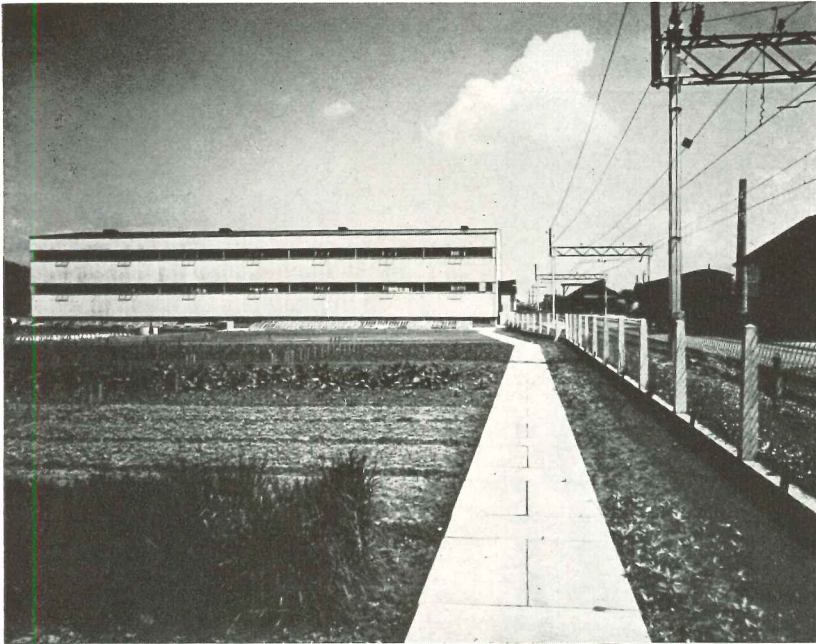

VERTICAL SECTION OF EXTERIOR WALL

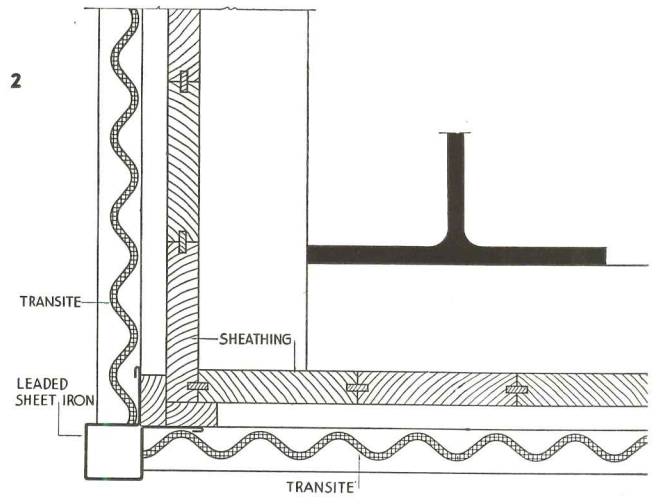

HORIZONTAL SECTION OF EXTERIOR WALL

1 Another view of the building from the garden. 2, 3 Interior views showing the structural elements and their relation to the continuous windows.



into the air. A wooden floor, if laid over an air space on concrete, would provide a paradise for mice (every little crack and crevice of any kind had to be prevented). The floor boards,  $1\frac{5}{8}$ " thick, are on sleepers on steel beams. A steel skeleton is used throughout the building. The warehouse requires no heating system. The flower bulbs, being the only merchandise sensitive to cold, are kept separately in the heated dwelling.

The wood floors are stopped on a line with the inner face of the columns, leaving a 16-inch air space to the wall for the all-important ventilation.

The columns are faced to the outside only. The facing is of corrugated Transite laid over sheathing with an air space of about 2 inches in between. Corrugated Transite is the ideal material for this type of dry construction. It insulates, is waterproof, has good strength on account of the corrugations, and can be had in large sheets up to 12 feet long; it can be attached in short order by any roofing man. It is easily sawed and drilled. The sheets are fastened on by zinc-coated screws which do not rust. Transite excels corrugated iron in being rust-free and requiring no paint. Its natural gray color and grooved surface are very pleasing to the eye.

To prevent the possibility of staining of the Transite by any rusty water it was necessary that all outside metal details be actually rustproof.

The windows and their drips, and the metal angle strips at the corners of the building, were all leaded by a system called "Tantol." The protective lead covering is deposited electrically on metal previously sand-blasted and carefully cleaned. Thus is achieved a closely-bonded galvanization with a thickness of less than  $1/10$  mm. Since no acid is used there is no danger of rusting from within and, since the process is all cold, there is no danger of expansion and contraction, an especial advantage in the case of lightweight windows. Lead coating can be put on in any desired thickness. As a last step it is covered with a hardening aluminum paint.

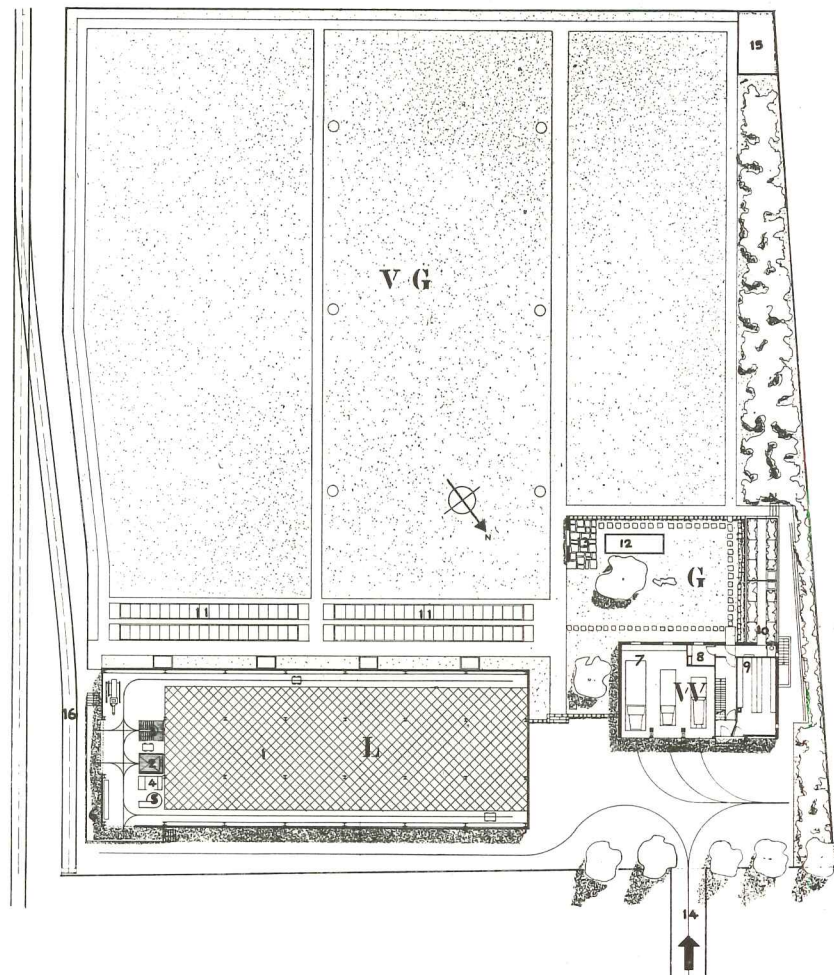

**LAYOUT PLAN:**

**L** Storage Building. **W** Residence of the Manager. **G** Garden Attached to the Residence. **VG** Experimental Garden.

**1** Storage Space. **2** Elevator. **3** Stairs. **4** Office. **5** Chute for Bags. **6** Loading Platforms. **7** Garage. **8** Laboratory. **9** Heated Space for Storage. **10** Hothouse. **11** Cold Frames. **12** Water Pool. **13** Covered Terrace. **14** Automobile Entrance. **15** Fertilizer. **16** Railroad Tracks.

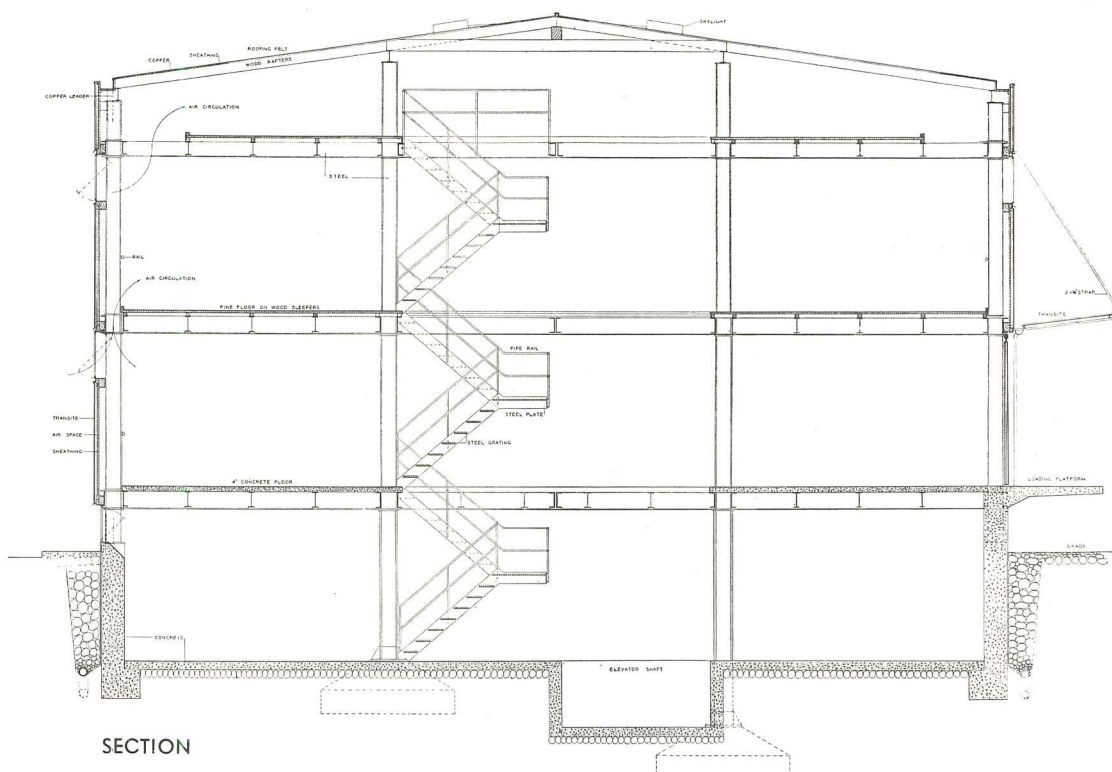

**SECTION**

(Continued on page 40BT)





1



2

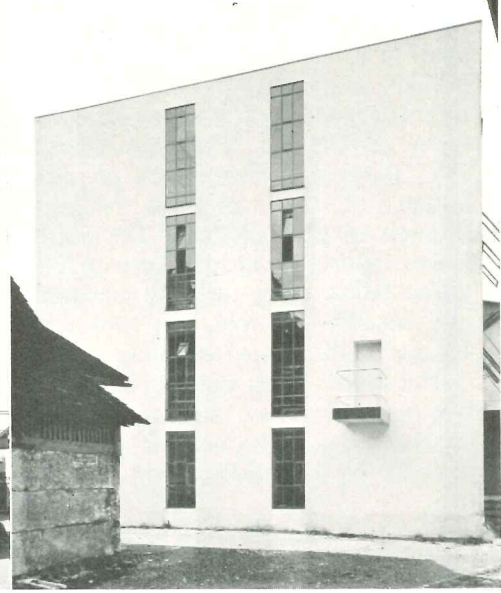

3

# FACTORY AT

## ALFRED ROTH ARCHITECT

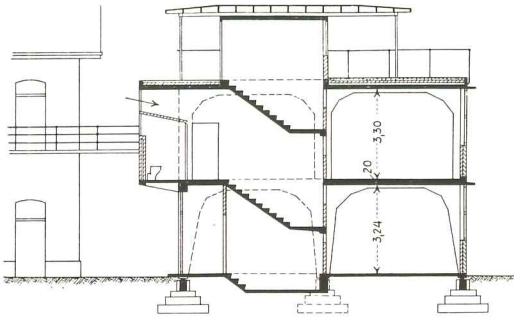

SECTION

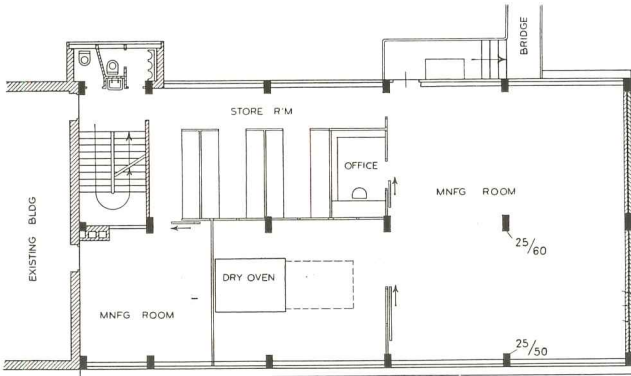

SECOND FLOOR PLAN

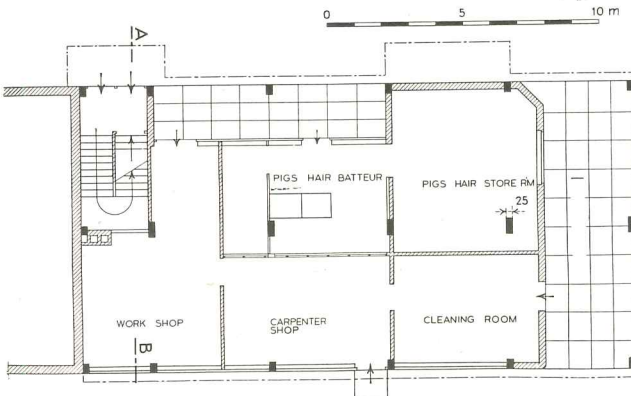

FIRST FLOOR PLAN

1 North elevation with connecting bridge.  
2 East elevation. 3 Storage.



Detail of concrete frame reinforcement

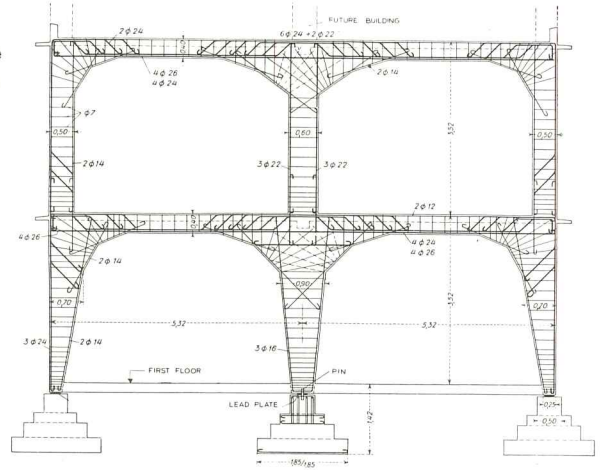

Roof construction

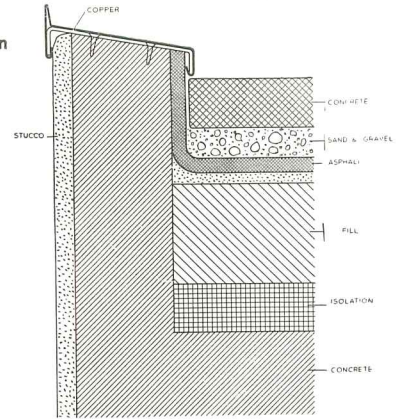

# WANGEN, SWITZERLAND

1, 2 North and South elevations. 3 Interior view of the second floor.

*Grete Hubacher*

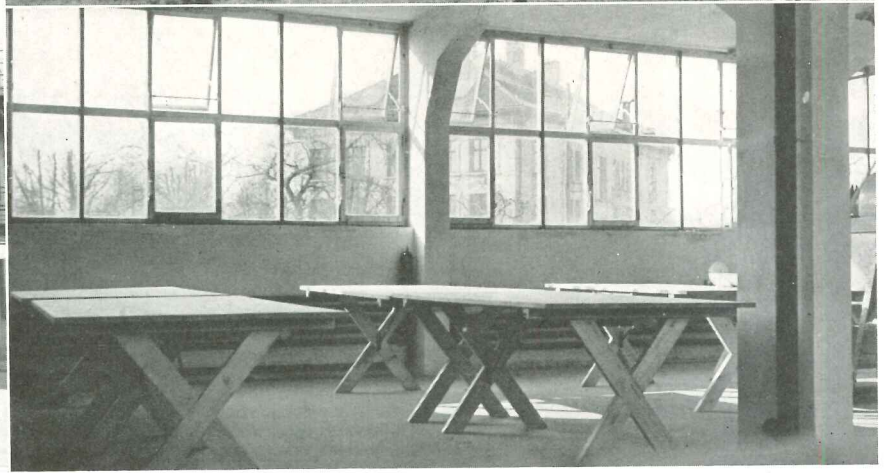

2

3



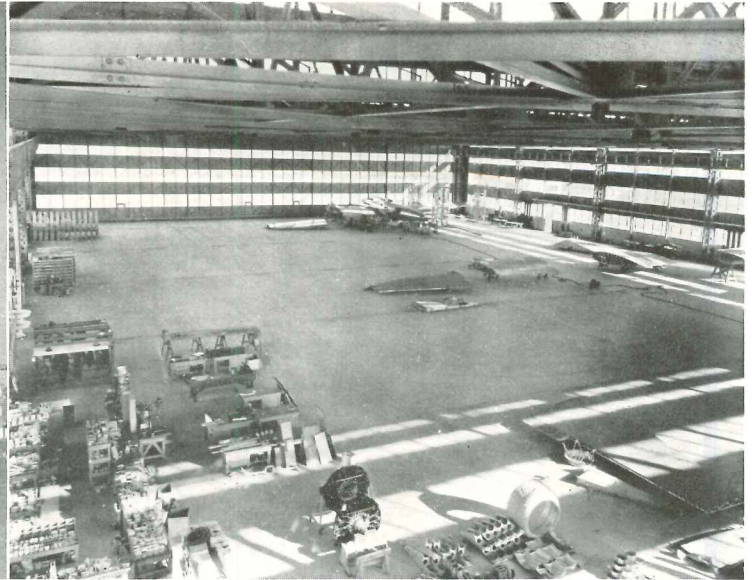
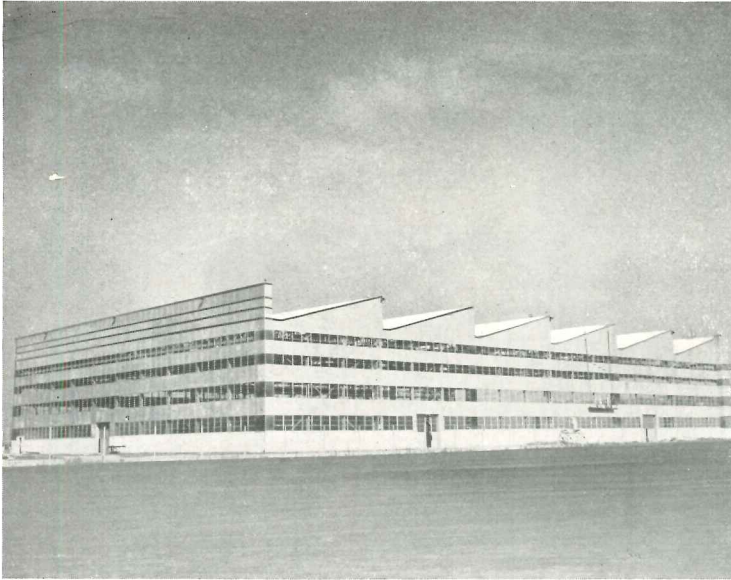

1, 2 BOEING AIRCRAFT ASSEMBLY PLANT AT BOEING FIELD, SEATTLE, WASHINGTON, with an unobstructed area of 204 feet by 304 feet and clear height of 35 feet. Designed by The Austin Company. 3, 4 PLANT FOR the manufacture of GAR WOOD road-building machinery at HIGHLAND PARK, MICHIGAN. Giffels and Vallet, Architects. 5, 6, 7 OWENS-ILLINOIS CAN COMPANY PLANT, BALTIMORE, MARYLAND. Francisco and Jacobus, Architects and Engineers. The photographs were taken October 20 during the driving of the 1,200 piles, November 5 when the steel erection was completed, and December 10 when the building was ready for manufacture. Glass bricks were used on three sides of the building.

5

Oct. 20

6

Nov. 5

7

Dec 10

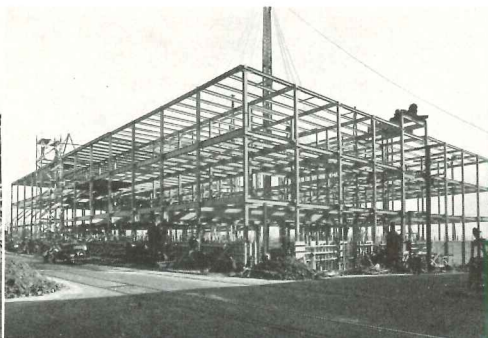

Photographs by The Hughes Co.





1

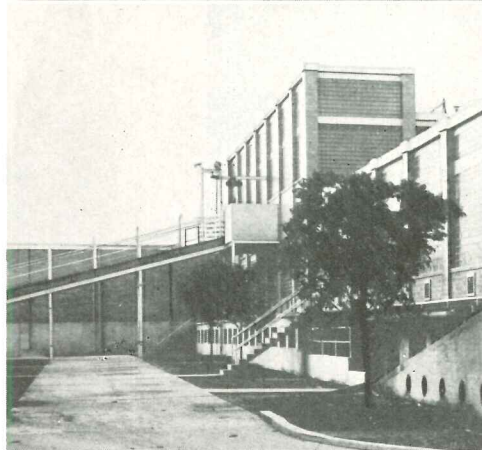

2



3

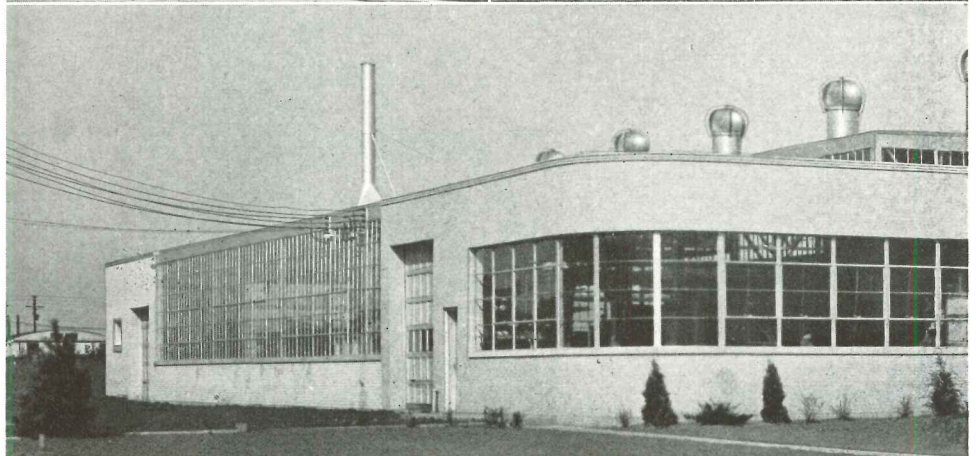

4

1, 2 CUDAHY PACKING COMPANY PLANT AT ALBANY, GEORGIA, without windows and air conditioned throughout. 30,000 Insulux glass blocks were used for the exterior walls. 3, 4 THE ALLEN CORPORATION PLANT, DETROIT, MICHIGAN. Designed by The Austin Company. The Allen Corporation manufactures turbine ventilators which are used in this building. Photograph 3 shows location of offices of the plant.



# AUTO ASS FOR GENERAL MO LINDEN,

ALBERT KAHN, INC.  
ARCHITECTS



1



2



3

1 Side of wall for glazing of assembly plant building. 2 Structure of main roof showing shaping of steel, all of which is welded. This shape of roof permits overhead daylighting. Also note partial placement of precast concrete roof slabs. 3 Preparation for reinforced concrete floor.

*Photographs by Max Zimmerman*



# ABLY PLANT ORS COMPANY NEW JERSEY

SCOPE: Factory Building, 1 and 2 stories, 108' x 661'; Office Building, 2 stories and base, 200' x 45'; Power Plant, 64' high, 89' x 107'; Loading Dock, 1 story, 450' x 50'; Acetylene and Oxygen Building; Pump House and Tank; Watchman's House; Parking Spaces, Sidewalks and Drives.

This structure is built of reinforced concrete and brick; walls of factory sash; glazed skylights; roof of 1" thick precast concrete "Federal" slabs; "Le-high" reinforced floors; welded frame in parts; built-up roofing.

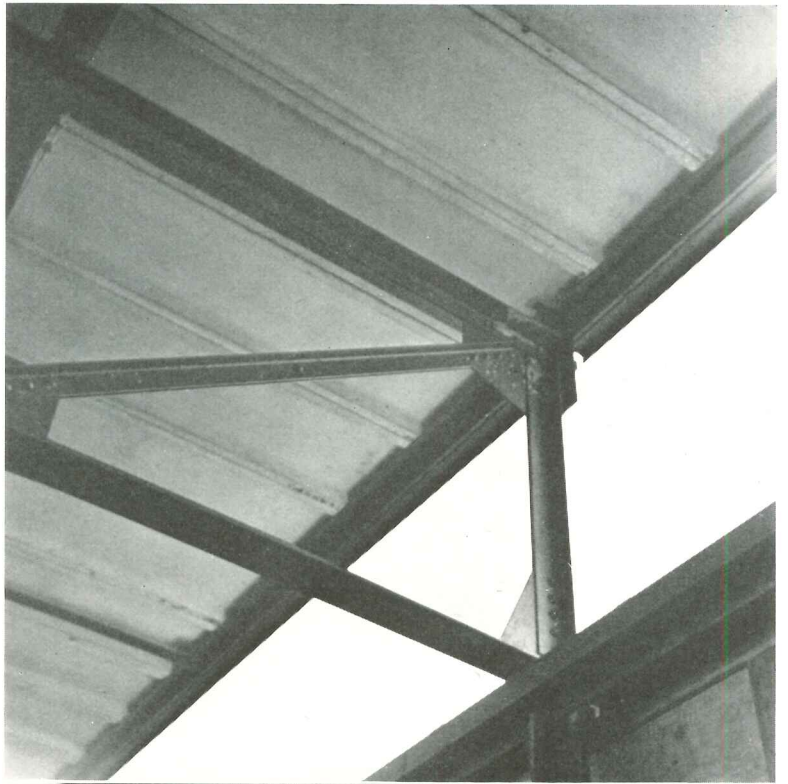

4

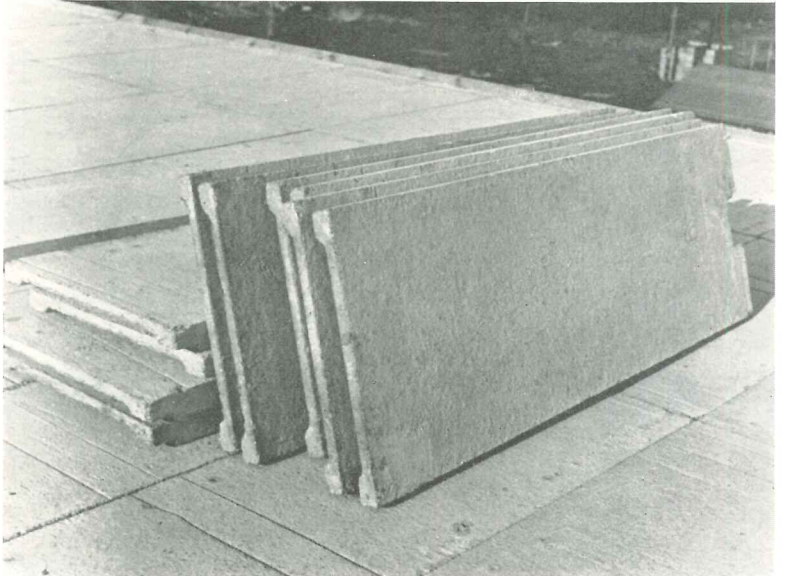

5



6

4 Detail of roof showing underside of concrete slab. 5 Detail of slabs. 6 Mopping down the roof for laying of built-up roof.



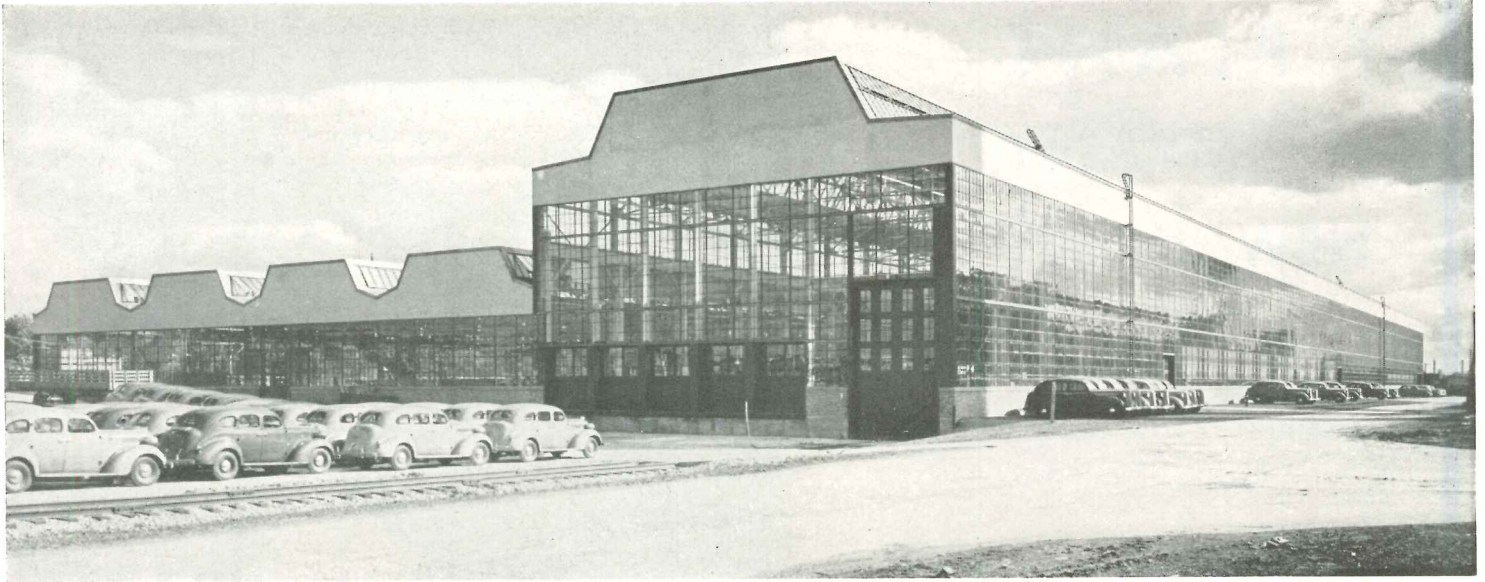

Photograph by Fred Egbert

1

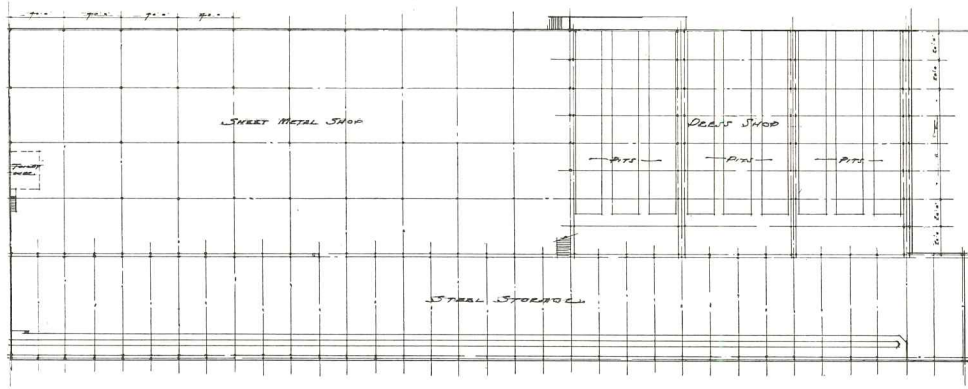

# THREE FACTORIES DESIGNED BY ALBERT KAHN

2

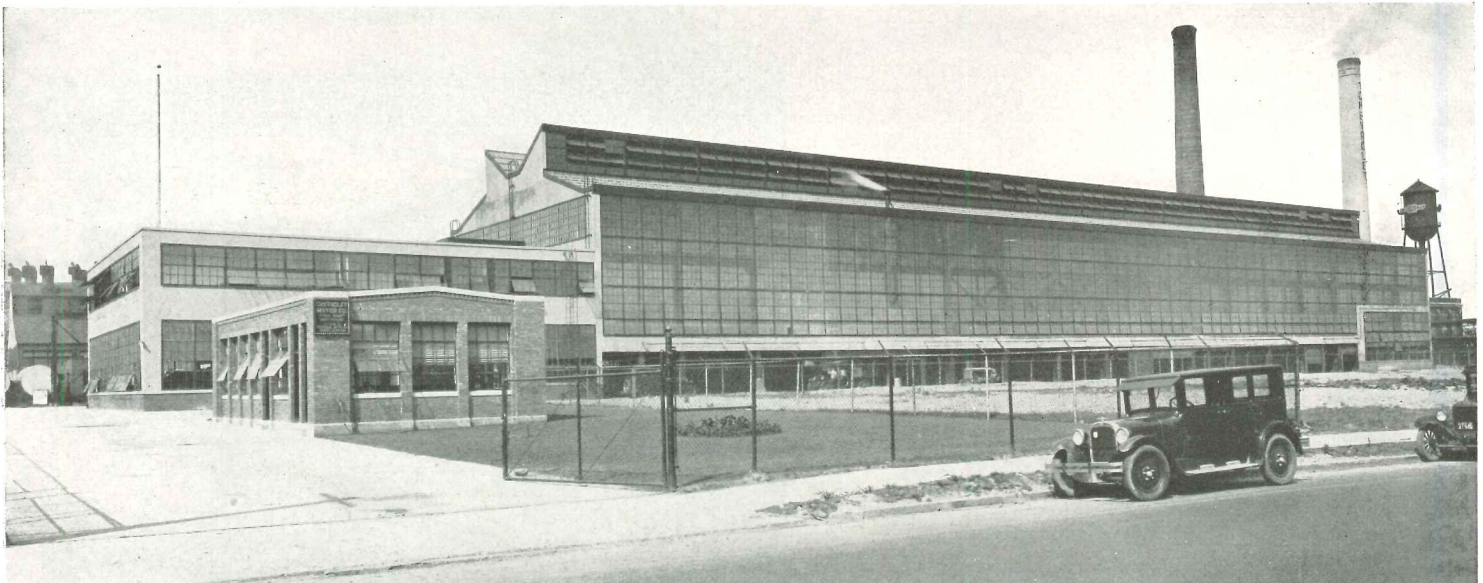



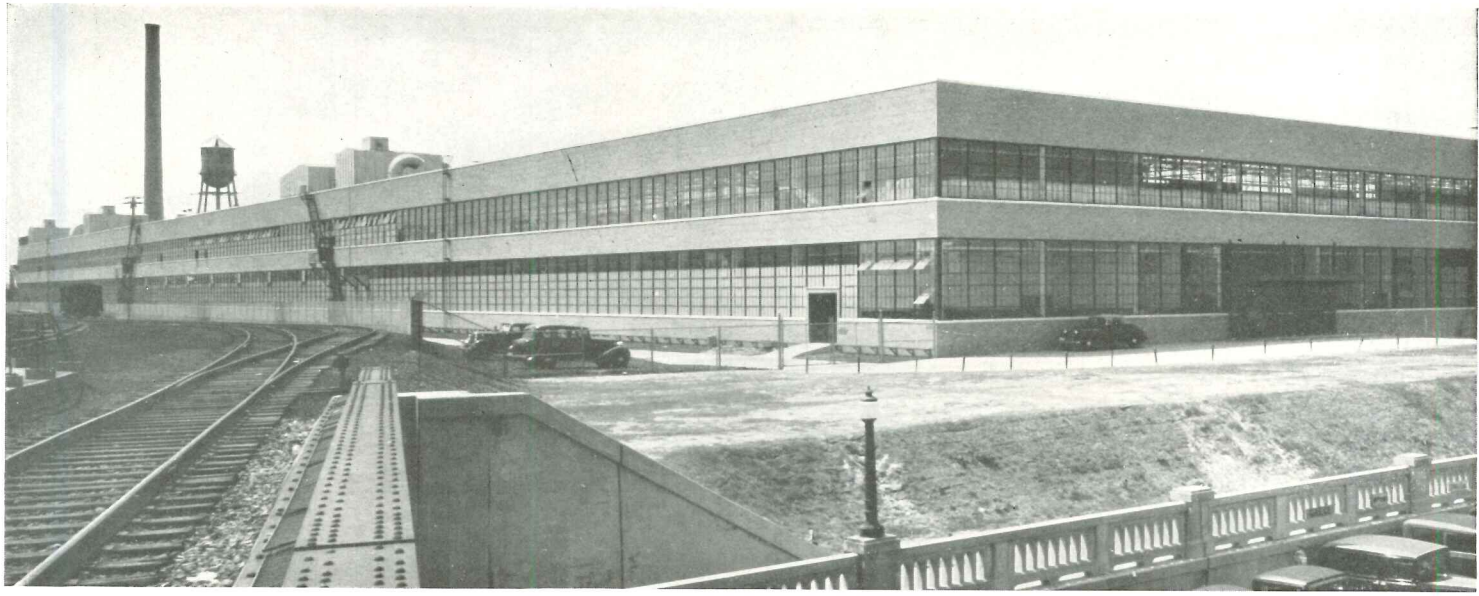

3

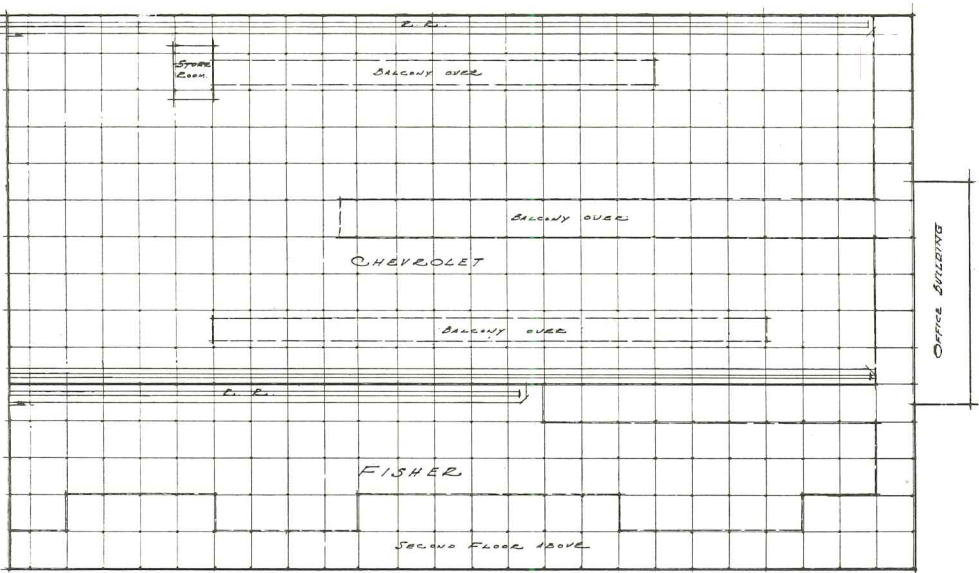

1 PRESS SHOP of the CHRYSLER CORPORATION at DETROIT, MICHIGAN. The plan shows the use of 40 x 40 span for the sheet metal shop and 20 x 80 for the dress shop. 2 FORGE SHOP FOR THE CHEVROLET MOTOR CORPORATION AT DETROIT, MICHIGAN. 3, 4 ASSEMBLY PLANT OF THE CHEVROLET MOTOR COMPANY, BALTIMORE, MARYLAND, with 27 1/2 bays, 40 x 40 feet.

4

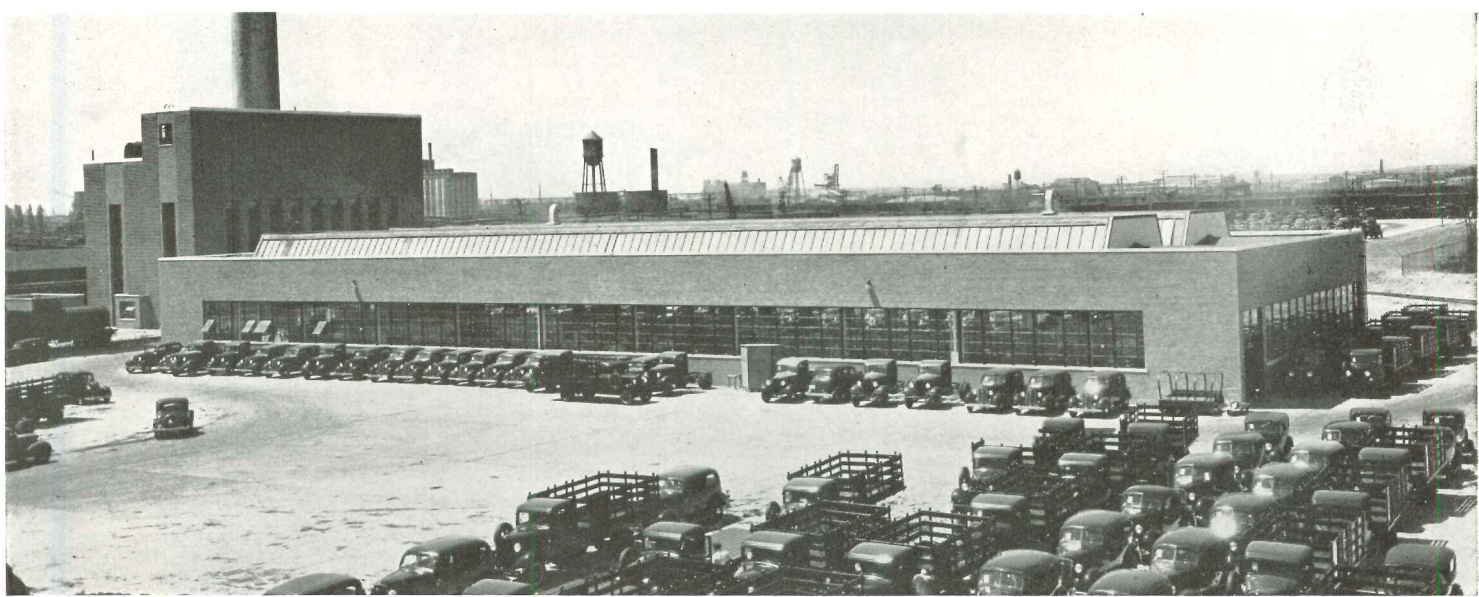



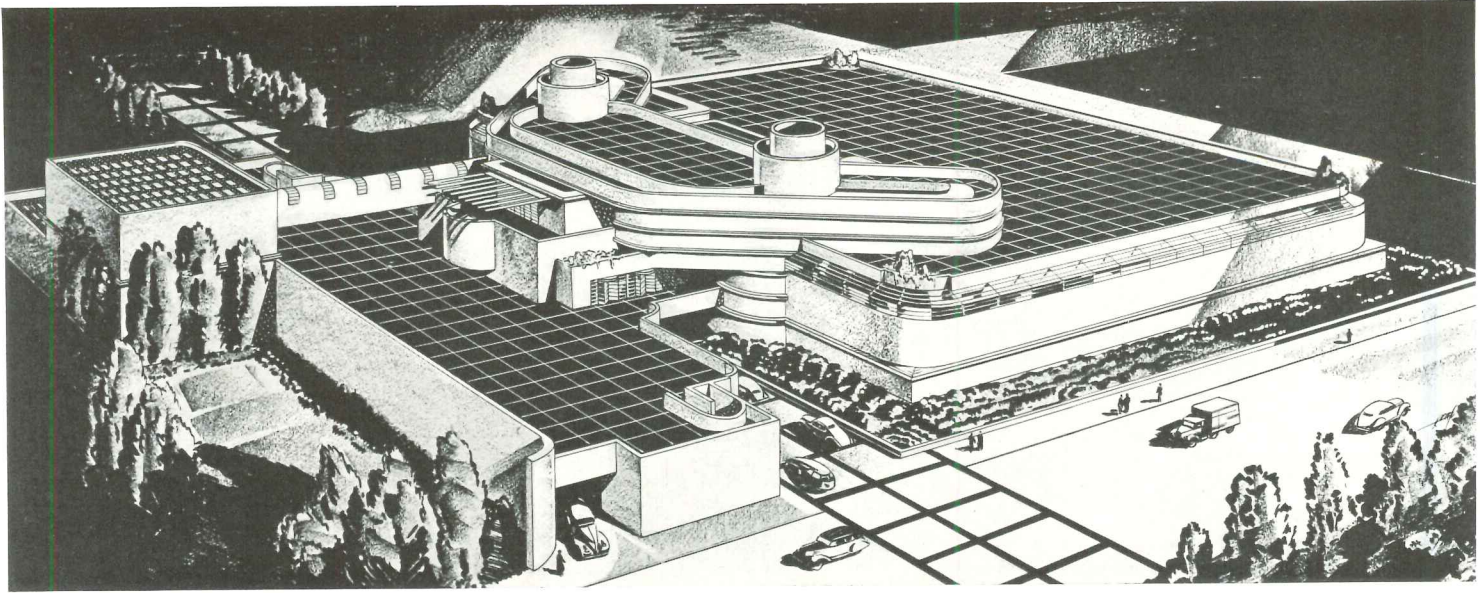

OFFICE BUILDING FOR S. C. JOHNSON & SON, INC., AT RACINE, WISCONSIN. Frank Lloyd Wright, Architect. Daylight will enter the building through parallel tubular-shaped cylinder glass which encircles it; artificial lighting will emanate from the same source. The only exterior openings are the entrance doors.

SEWAGE DISPOSAL PLANT, near HIGHTSTOWN, NEW JERSEY. Alfred Kastner, Architect; Stanton M. Dorsey, Sanitary Engineer.

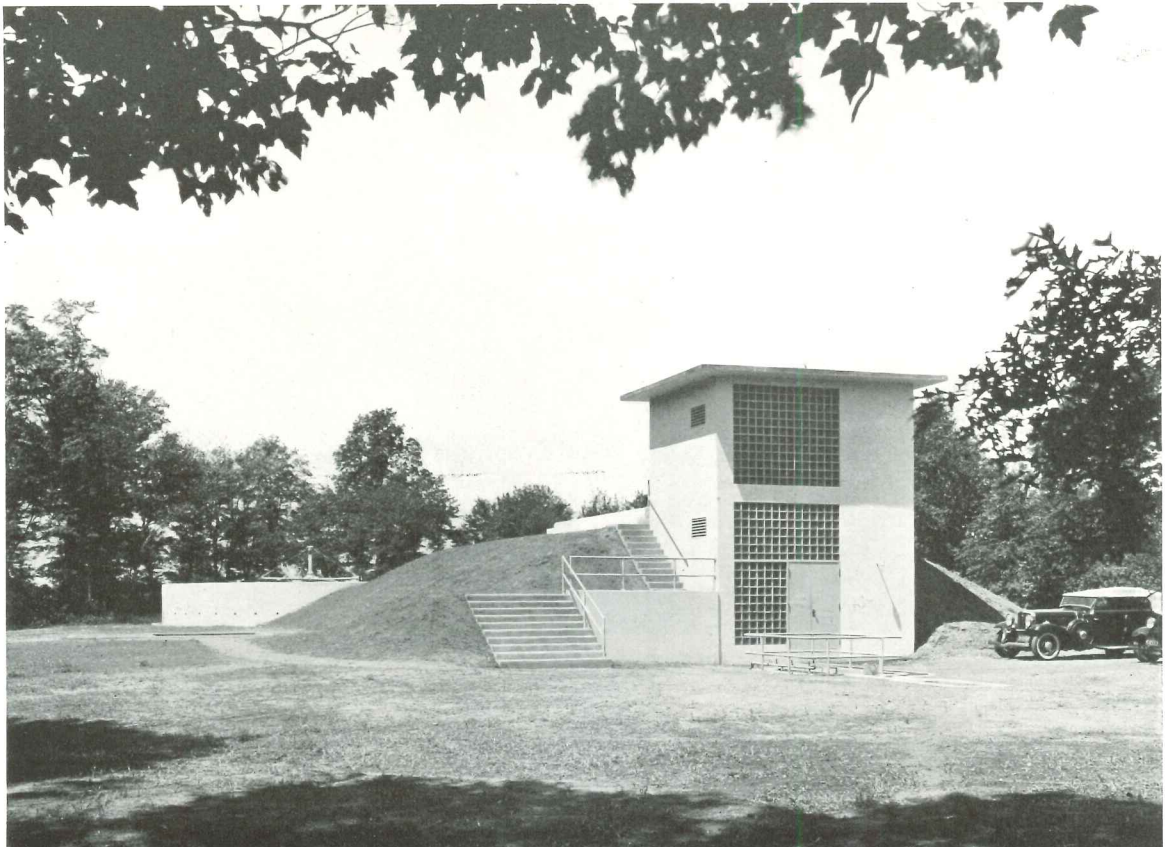

Photograph by F. S. Lincoln



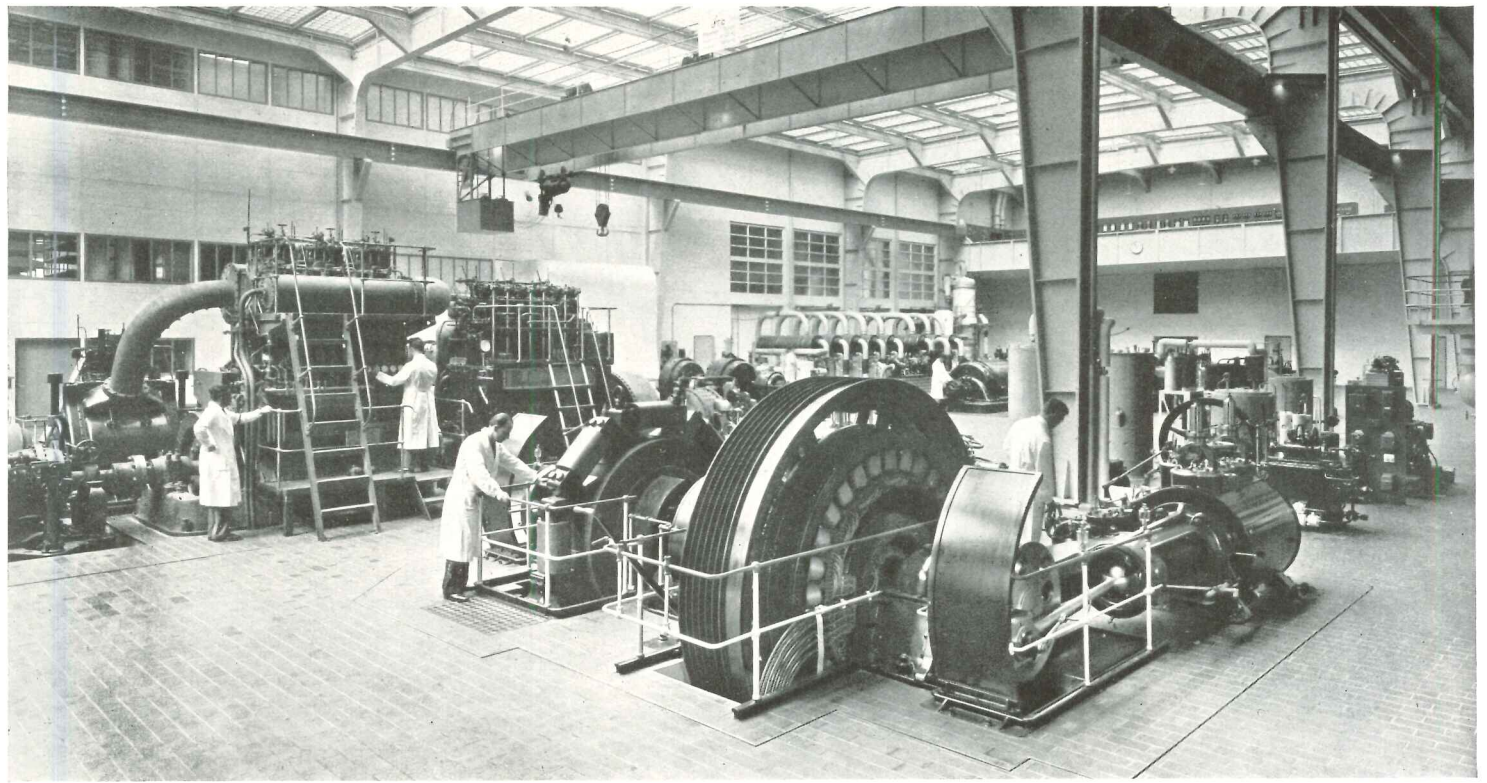

# THE POWER PLANT OF THE FEDERAL TECHNICAL SCHOOL

## ZURICH, SWITZERLAND

PROFESSOR O. H. SALVISBERG, Architect

Among the new buildings of the Federal Technical School (E. T. H.) of Zurich, designed by Professor Salvisberg, there is a power-house and a machine hall, both taking the place of older buildings which were no longer fitted for up-to-date technical equipment. The boiler house is built in reinforced concrete. Two elevations have glass walls, the glass being framed

directly to the concrete. The stack is 207 feet high and, with the cooling tower, forms the main feature of the school in contrast with the lower horizontal structures. As in most of the works of Professor Salvisberg, no exterior finish was given to the concrete surface.

The coal arrives by train from underground railroad tracks or by truck and it is pneumatically hoisted to the bunkers located by the cooling tower.

The large wall of welded steel construction has a clear span of 73 feet and houses, besides the power and control rooms, the machinery of the various technical departments of the school.

It will be interesting, perhaps, to note the following quotation from

Professor Salvisberg in relation to the old buildings of the school: "When before the buildings were defying time, now the thickest walls cannot resist the progress of the technic. The main tower of the school, built in 1898 and which appeared to be erected for eternity, did not last 40 years and was demolished during the life of its builder."



2

3

1 Interior view of the machine hall; at the far end is the mezzanine where the control room is located. 2 View of the stack, the cooling tower, the power-house and the machine laboratories. 3 The stack, showing the repetition of standard concrete forms.



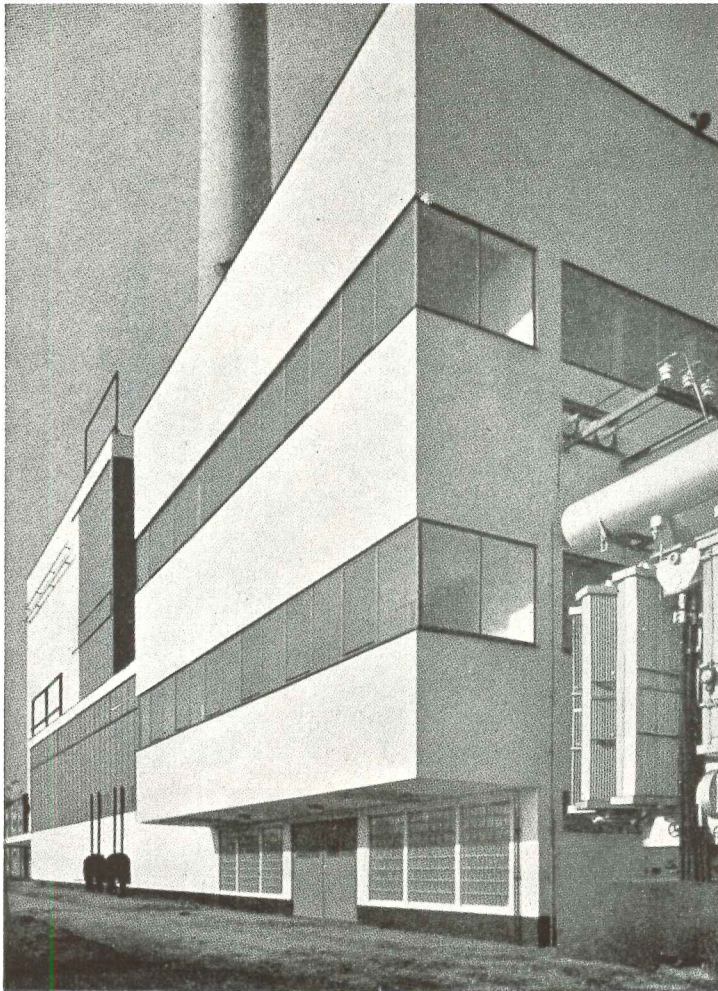

ELEVATION OF THE PLAN FACING THE RIVER

# POWER STATION KOLIN, CZECHOSLOVAKIA

JAROSLAV FRAGNER, Architect

*Illustrations, Industrial Architecture*

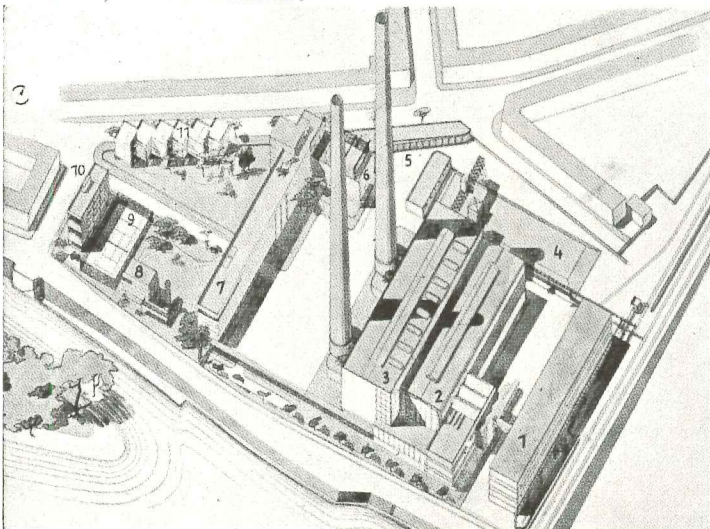

**Layout of the Plant:**

- 1 Switch house
- 2 Engine room
- 3 Boiler room
- 4 Coal storage
- 5 Garages
- 6,7 Offices and manufacturing of electric meters
- 8 Residence of plant manager
- 9 Playground
- 10 Flats for foremen
- 11 Workers' flats



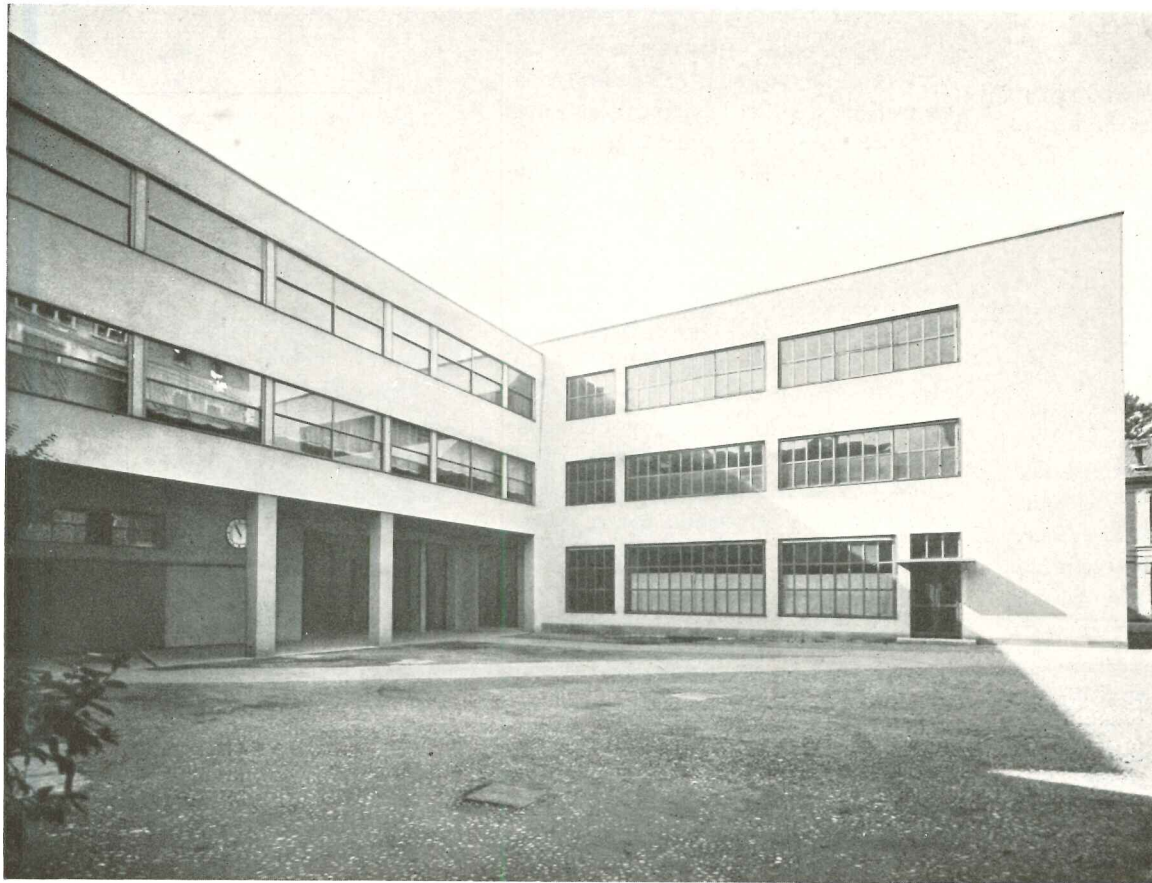

# ANGELI-FRUA PRINTING WORKS MILAN, ITALY

BALDESSARI, FIGINI, POLLINI, Architects

1 View of the loading and dispatch bay. 2 Windows of the composing room.

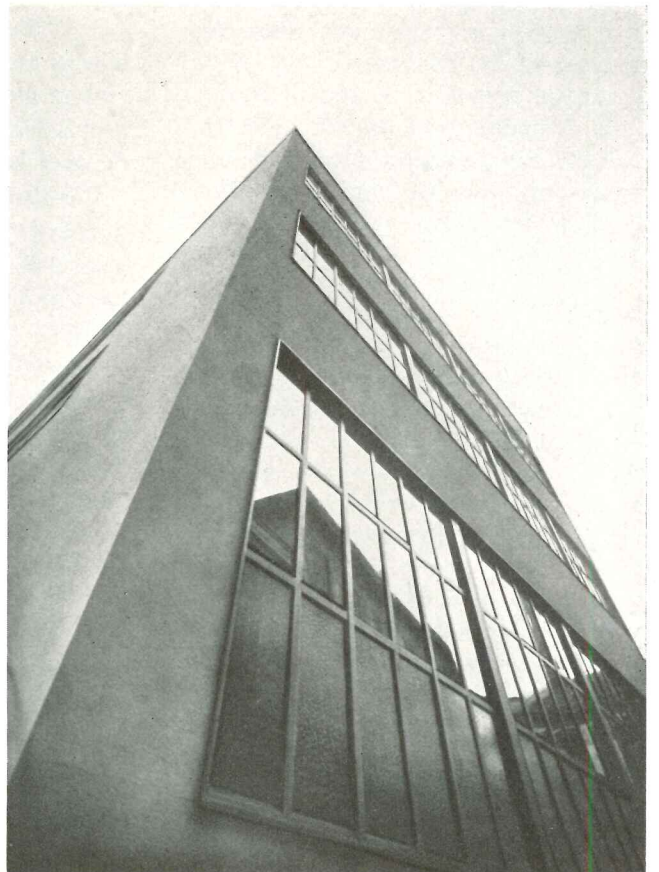



## B. LAYOUT

(Continued from page 10 BT)

rooms, a consultation room, office space, a large waiting room and two wards, for men and women. The width of the doors should be at least 3' for the passage of stretchers.

**CLOAKROOMS AND LAVATORIES:** There are two ways of providing cloakrooms: a general cloakroom near the factory entrance, one for each sex, or smaller cloakrooms for every department or shop. The last named are more in use because the workers can enter the shop without being exposed again to the weather. Entrance and exit must be separated to obtain an unobstructed circulation. Good ventilation must also be provided. Sanitary accommodations should not be far from the workshops to avoid loss of time. The number of conveniences to be provided is determined by the local regulations, but generally there should be one toilet for every 25 workers up to 100 and one every forty thereafter. If toilets are connected to a shop, they should be isolated by a well-ventilated hall. For the lavatories, long ranges or circular wash sinks with a continuous stream of water in a suitable temperature, open when required or controlled by foot pedals, are the most desirable. Because of the character of the product or the operations in some factories it is compulsory to provide showers. But there is a tendency toward the use of showers when the work is especially dirty or performed under an extreme heat.

**CANTEENS:** Canteens may provide a shelter where the workers have their meals which they bring from home, with certain facilities for warming the food and for hot water for coffee, or they may offer a restaurant service. In the case where clerical workers and management officers have their meals at the factory, more than one dining room must be provided. Their area will depend upon the number of persons to be accommodated, with a minimum of ten square feet per person. The area of the kitchen may reach 50% of the dining room. The kitchen should be directly accessible from outside and with toilet facilities for its attendants. It is advantageous that

the canteen have a covered access from the cloakrooms. Since the canteen very often serves as a recreation room as well as for various social activities after working hours, it must be located near the main gate and be easily accessible from the street in order to avoid crossings of the factory grounds.

**OFFICES:** Office space may be needed only for the factory superintendent, in which case his office should be located at the entrance of the works or in a mezzanine. But very often the sales and research departments are located within the factory grounds and there must be provision for a special building. The office of the factory superintendent should have easy access to every point of the plant, therefore it must be located at the ground floor of the office building, which will be occupied also by the employment and pay offices. The upper floors should be used by the sales and records departments. Laboratories, designing rooms, and research departments must be located at the top floor where they can have the advantage of skylights. The offices of the foremen are situated in the workshops and they are simply screened by glass partitions.

## C. CONSTRUCTION

(Continued from page 14 BT)

attacks as are steel sash, and does not require any maintenance expense; but its particular use must be in air conditioned buildings.

Ventilation can be provided by a sufficient number of windows. A natural flow is thus obtained owing to the difference of temperature, the wind pressure, or both combined; or it may be necessary to install a mechanical system to remove the heat smoke and fumes. Six air changes per hour are considered as basic, but in some forge shops 50 and 60 changes per hour are required to keep down the inside temperature. The ventilation should always be figured for summer when more air changes are needed and there must be a chance to reduce the number of changes during the winter.

In some industries such as textile, paper, wood, leather, cigarettes and food, the physical properties of the product are affected by the tempera-

ture and the humidity. Then the use of an air conditioning system and humidity control is required for a minimum loss of materials and for a permanent adjustment of the machinery. Attention must be given to the condensation of humidity, and suitable materials should be used or facility provided for drainage. Air leakages will add considerably to the operation cost, as will inadequate insulation.

Some factories have been built lately depending entirely on artificial lighting and ventilation, with the intention of providing ideal and steady working conditions. There is a complete absence of windows of any kind, or transparent walls, and the whole building is airtight.

Examples of the above treatment are the factory of the Hershey Chocolate Company at Hershey, Pennsylvania, and the Sears Roebuck warehouse in Chicago. At the first factory there is use of indirect mercury vapor lighting with Mazda lamps. As the employees within the building were showing an increasing interest in the outside weather conditions, a system of signals was established to indicate the weather changes: white light for clear weather, red light for rain, green for snow, etc. And the offices were lined with compressed cork to absorb the voices and sounds, which acquired a high tensility, owing to the fact that they were not counteracted by any outside noises.

## SEED STORAGE BUILDING

(Continued from page 27 BT)

The roof water drains off to one side of the building through leaders into four concrete tanks from which the water is available for the garden. The tanks are connected and overflow into the sewer.

The cellar is insulated against dampness so that in the future it, too, can be used for seeds.

The dry construction made possible very swift erection. The cost of the warehouse alone, including the architect's and engineer's fees, is 22c a cubic foot—very reasonable indeed for Switzerland.







# ARCHITECTURAL PRACTICE AND DESIGN IN ENGLAND

*A general survey of architecture in England at this time should have exceptional news value for American architects. During the depression many architects in America came to believe that, when the building industry revived, the conditions of practice and the vocabulary of design in the United States would differ radically from those of the postwar period. The partial revival which has so far taken place is too recent and too limited to offer clear evidence with respect to any of the more important departures suggested by developments conspicuous during the depression.*

*Among the questions brought into prominence by the depression may be mentioned: Does the relative increase in salaried employment of architects by manufacturers, government units and contractors, compared with private practice, represent a permanent drift threatening extinction of the fee system? Are new materials and new construction methods about to gain largely at the expense of the old? Will modern design forms be widely accepted? Are recent developments in technology, legislation and social attitudes vital enough to bring about noteworthy progress in architecture?*

*These and other questions of importance to architecture have been raised in England as well as in America. In England they have to some extent been answered, at least temporarily, by experience in a building industry which has now been active for several years. A survey of existing design preferences and conditions of practice in England should therefore provide timely information and reveal trends inferentially applicable to the profession in America. Such a survey has been arranged for by an exchange of editors with *The Architectural Review* of London, in the March issue of which A. Lawrence Kocher of *The Architectural Record* edits a section on American Architecture while H. de Cronin Hastings of *The Review* edits a corresponding section on English Architecture in *The Record*.*

***The English section in *The Record* for March is a notable example of editorial quality in conception, selective collaboration and typographical make-up. Acknowledgment of credit for the quality of contents and page arrangements of this issue is made to Mr. Hastings and to his able assistants, A. E. Doyle and J. M. Richards. The scope and authenticity of its contents are suggested by the following list of contributions and contributors:***

<i>English Architecture, 1860-1930</i>	By Nikolaus Pevsner
<i>The English Scene</i>	By Hugh Casson
<i>Planning in Town and Country</i>	By Thomas Sharp
<i>The Architect and His Patrons</i>	By J. M. Richards
<i>The Work of The Architect</i>	By L. W. Thornton-White
<i>Professional Organizations</i>	By James Macquedy
<i>Education</i>	By John Madge
<i>Professional Practice</i>	By Julian Leathart
<i>Building Legislation</i>	By W. E. J. Budgen
<i>A Characteristic</i>	By Paul Nash
<i>Where England Looks to America</i>	By Herbert Read

*A feature of the English section which deserves special mention is the great number of illustrations. The result is a comprehensive view in large plates of modern design recently executed and a retrospect in small text illustrations of the evolution of modern design in England. This evolution is of particular interest because it is based on English tradition and owes very little to the Continent.*